



# Lexmark XS748de

Intuitive color MFPs for busy workgroups



Color



Touch screen



Copy



Scan



Fax



Solutions



Up to 35 ppm



Duplex



Network



Eco-mode



Security



Flexible input



Founded in 1991 from an IBM heritage in Lexington, Kentucky, Lexmark is one of the few American companies to own, develop and market, monochrome and color laser print technologies. Lexmark is poised to deliver on its promise to produce quality, dependable products well into the future.

### Robust high-quality color

Rely on Lexmark XS748de color laser MFPs for the high-quality color printing, scanning and copying essential to business.

- ▶ Match corporate colors with Lexmark Color Replacement and PANTONE® calibration
- ▶ Lexmark high-yield cartridges let you print up to 12,000 pages per cartridge in black and 10,000 pages per cartridge in color
- ▶ Print and copy quickly at speeds up to 35 ppm and a time to first page as fast as nine seconds in both black and color
- ▶ The high-speed processor, 512 MB RAM and Gigabit Ethernet networking mean fast data transfer and fast processing even on complex color documents
- ▶ Ultra-reliable paper feeding supports diverse media, including card stock, vinyl labels, banners and more

### Performance and productivity

The combination of easy-to-use features and reliable performance means business processes are intuitive and you are productive.

- ▶ The easy-to-use 7-inch (17.8-cm) color touch screen provides audible feedback and tablet-like navigation
- ▶ Expand input capacity with optional paper trays and boost total input capacity up to 3,200 sheets
- ▶ Quickly print and copy documents using the instant warm-up fuser that also reduces energy consumption
- ▶ Create custom messages to provide helpful information such as helpdesk telephone numbers and company communications
- ▶ Instead of installing individual drivers for each printer model, the Lexmark Universal Print Driver provides a standardized, one-driver solution

### Business solutions

The Lexmark Embedded Solutions Framework (eSF) helps expand functionality, move information, lower costs and analyze usage patterns

- ▶ Quickly and efficiently access basic eSF solutions directly from the 7-inch (17.8-cm) color touch screen
- ▶ The optional hard disk provides the ability to store files on the device and run additional solutions with ease
- ▶ Pre-loaded solutions mean you can be productive and save time, money and paper right out of the box
- ▶ Additional solutions are available for greater savings and productivity
- ▶ Models with solutions capabilities also have the card reader option for greater security

Average continuous black or composite CMY declared cartridge yield in accordance with ISO/IEC 19798.



### Why Lexmark color?

The documents you print define an important image—yours. Lexmark XS748de color laser MFPs are perfect for printing reports, marketing collateral and on-demand signage with brilliant color reproduction. So when you put a high-quality color document in a client's hands, you're advancing communication and your company's image at the same time.

### Professional color quality

Color communicates, informs and persuades. Vibrant, expressive color also attracts attention and increases impact. In short, color is your brand—who you are. Lexmark XS748de color laser MFPs are color powerhouses. They offer repeatable, accurate color matching and features that create continuity from one document to the next.

- ▶ **Easy brand matching:** Match corporate colors on marketing collateral and logos with Lexmark Color Replacement. Simply enter specific color values for easy color matching, including company defined colors and PANTONE® color.
- ▶ **Money-saving color:** Color is business critical, but often it is seen as expensive or wasteful. Lexmark ColorCare Technology helps change that perception. Tools like User Quotas help you manage and make intelligent decisions about color printing.
- ▶ **Continuous color:** Print with confidence knowing Lexmark XS748de color laser MFPs produce documents at optimum quality. Status screens and supply alerts notify you when toner is low so you don't run out in the middle of a job.

### Professional color performance

Whether you need one document or many, consistency is important. Lexmark XS748de color laser MFPs deliver in all types of situations—last minute presentations, large print jobs for promotional events or constantly used forms.

They create high-quality documents on a variety of media while helping you save money at the same time.

- ▶ **Consistent color across media:** Lexmark color technology gives you consistent, professional color on a variety of media types and sizes. Carry a consistent look across materials and show clients your true colors, no matter what you give them.
- ▶ **Print on demand:** Eliminate waste. Don't print forms, marketing materials or other documents externally and store the paper versions. Instead, with the Forms and Favorites solution, store frequently required files online and print in-house and on demand.
- ▶ **On-the-fly updates:** Create custom color documents directly from Lexmark XS748de color laser MFPs. Use print preview and post process job changes to make updates like removing a cover page or switching between simplex and duplex printing.



### Lexmark XS748de solutions

Reduce unnecessary printing and simplify work processes through Lexmark solutions. The Lexmark Embedded Solutions Framework (eSF) enables you to add a wide range of software apps directly onto the device. Solutions are designed with your productivity in mind, helping you streamline—or even eliminate—paper-intensive business processes.

### Lexmark XS748de built-in solutions

The following apps are preloaded on Lexmark XS748de color laser MFPs.



#### Forms and Favorites

Eliminate waste and inefficiencies associated with preprinted forms. Rather than printing collateral externally and storing the paper versions, store frequently required files online. Then print them in house and on demand.

Example: An office has a form that clients are required to sign. The form is stored and employees print the form as new clients are accepted.



#### Eco-Settings

Print responsibly, save money and reduce waste with little effort. Choose from multiple print settings that help reduce energy, paper and toner consumption using custom eco-settings.

Example: An MFP is used infrequently so the device is configured to go into power saver mode after the device has been idle for five minutes.



#### Showroom

Display a customizable, scrolling slideshow on the color touch screen to communicate important messages to customers or employees while the device is in power save mode.

Example: A company is announcing a new supplies ordering process. The steps are included on the device as a reminder to employees.



#### Change Background

Communicate to customers and employees and make the device truly your own. Customize the background or a timed idle screen to show one of the four preloaded backgrounds or any image you want, such as a photo or logo.

Example: An MFP is used in an area visible to customers. The background and idle screen is updated to display the company logo.



### Lexmark XS748de additional solutions

In addition to the solutions built into the device, a diverse portfolio of additional Lexmark solutions is available to help accommodate your workflow needs. The following are just a few examples.



#### Capture and Route

Capture, store and share business documents and benefit from improved cycle times and increased efficiencies. Lexmark offers solutions that let you convert hardcopy documents into digital information with the touch of a button.

Example: Scan to Network lets you capture a digital image of hardcopy documents and route the file to a shared network folder. Immediately upon delivery, the file is available to anyone permitted to access the folder.

Related solutions:

- ▶ Scan to Email
- ▶ Scan to Network
- ▶ Scan to SharePoint
- ▶ Scan to Hard Drive



#### Mobility

Today, there are many ways to implement mobile printing but no single solution that fits all. Select from multiple mobility-related solutions that enable your business or organization to capitalize on the benefits of mobile productivity.

Example: The Lexmark App for Google Cloud Print solution enables you to easily and securely release print jobs that you send to Google Cloud Print. No PC is required to enable the printing process.

Related solutions:

- ▶ Lexmark Print Release
- ▶ Lexmark App for Google Cloud Print
- ▶ Lexmark App for Google Docs
- ▶ Lexmark Document Accounting



#### Education

Trainers and teachers, whether in a school or a business, want to spend more time teaching and less time doing paperwork. Lexmark offers several solutions that help lower the time barriers associated with preprinted test forms and manual scoring.

Example: The Summary Reports solution helps you respond to individual learning gaps or class comprehension issues with eight different reports that can be emailed, saved to a shared network folder or printed.

Related solutions:

- ▶ Scan to Classroom
- ▶ Print Tests
- ▶ Grade Tests
- ▶ Summary Reports

Contact your Lexmark Business Solutions Dealer for additional solutions.



**Easy brand matching**

Consistently match branded colors and print marketing collateral in house with Lexmark Named Color Replacement.



**Intuitive color touch screen**

Operate your printer with ease and confidence using the 7-inch (17.8-cm) color touch that makes navigation smart and intuitive.



Lexmark XS748de color laser MFP shown with optional 550/2000 sheet drawers and optional caster base



**Convenient updates**

Preview documents and change output settings, such as two-sided printing, directly at the device.



**Flexible input capacity**

With the optional 550-sheet trays and 2,000-sheet high capacity trays, customize input options to meet your printing needs.



**Two-sided printing**

Reduce paper consumption by up to 50% and reduce your impact on the environment with two-sided printing.



**Direct USB**

The front USB port allows for convenient walk-up preview, printing and scanning of PDFs and many printable image file formats.



**Eco-friendly printing**

Print responsibly with eco-settings that let you customize print settings and hibernate mode, which reduces energy consumption to less than 1 watt.



**Built-in security**

Advanced security controls protect data at every stage: From user authentication to security audits and disk wiping.

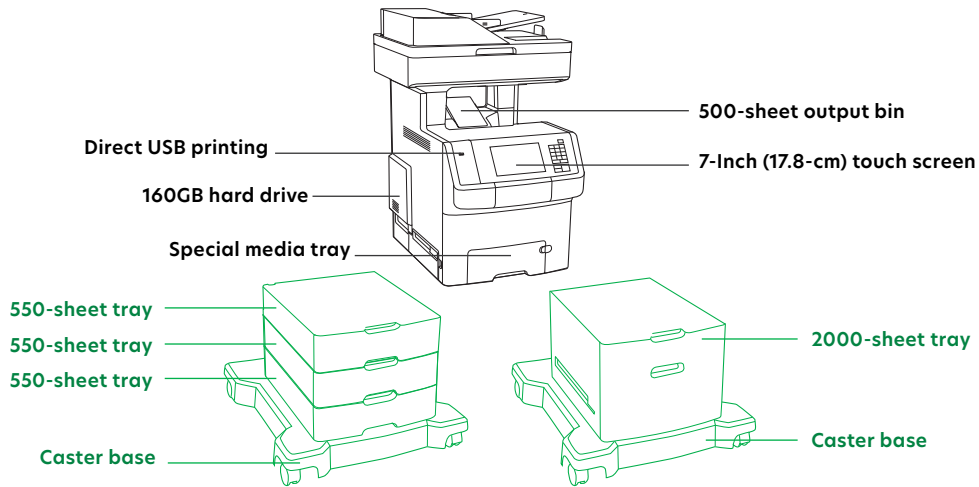

Standard  
 Optional

**Compatible with Lexmark XS748de MFP**

Part #	Model	Part #	Memory options
34T5123	Lexmark XS748e	1025041	256MB DDR2-DRAM
		1025042	512MB DDR2-DRAM
		1025043	1024MB DDR2-DRAM
		14F0245	256MB flash card
		27X0014	160+ GB hard disk
		30G0287	Arabic font card
		30G0828	Japanese font card
		30G0825	Korean font card
		30G0826	Simplified Chinese font card
		30G0827	Traditional Chinese font card
Part #	Laser toner/print cartridge	Part #	Application solutions
24B5700	XS748 Black High Yield Return Program Toner Cartridge	57X9000	Lexmark PrintCryption Card
24B5701	XS748 Cyan High Yield Return Program Toner Cartridge	34T5121	X746, X748 Card for IPDS
24B5702	XS748 Magenta High Yield Return Program Toner Cartridge	34T5122	X746, X748 Card for PRESCRIBE Emulation
24B5703	XS748 Yellow High Yield Return Program Toner Cartridge	34T5120	X746, X748 Forms and barcode card
C734X20G	Photoconductor Unit	3053996	Large pod for PKI card reader
C734X24G	Photoconductor Unit, 4-pack	57X0020	PKI Authentication App for eSF capable devices
C734X77G	Waste toner box	Part #	Connectivity
X746H2KG	X746, X748 Black High Yield Toner Cartridge	27X0025	MarkNet N8250 802.11b/g/n wireless print server
X748H2CG	X748 Cyan High Yield Toner Cartridge	14F0037	MarkNetTM N8020 Gigabit Ethernet print server
X748H2MG	X748 Magenta High Yield Toner Cartridge	1021294	USB (2 meter) cable
X748H2YG	X748 Yellow High Yield Toner Cartridge	14F0000	Parallel 1284-B Interface card
C734X44G	Photoconductor Unit, 4-pack TAA	14F0100	RS-232C Serial Interface card
24B5807	CS736, XS73x Black High Yield Return Program Toner Cartridge	Part #	User replaceable parts
24B5804	CS736, XS73x Cyan High Yield Return Program Toner Cartridge	40X8110	C74x, X74x Fuser Maintenance 110-120V
24B5805	CS736, XS73x Magenta High Yield Return Program Toner Cartridge	40X8111	C74x, X74x Fuser Maintenance 220-240V
24B5806	CS736, XS73x Yellow High Yield Return Program Toner Cartridge	40X8307	C74x, X74x Transfer Belt Maintenance Kit
Part #	Paper handling	40X5187	ADF separator pad
27S2100	500-sheet drawer	40X5188	ADF pick assembly
27S2400	2000-sheet high capacity feeder	40X5189	ADF pick pad
27S2650	550-sheet specialty media drawer	40X5168	Pick tire
27S2190	4.8 inch (12.2) spacer	40X5152	Pick tire, specialty media drawer
Part #	Furniture		
3052765	Swivel cabinet		
34T5114	C74x, X74x caster base		





Product specifications	Lexmark XS748de
<b>Printing</b>	
Display	Lexmark e-Task 7-inch (17.8 cm) color touch screen
Print Speed: Up to	Black: 35 ppm / Color: 35 ppm
Time to First Page: As fast as	Black: 9 seconds / Color: 9 seconds
Print Resolution	Black: 1200 x 1200 dpi, 4800 Color Quality (2400 x 600 dpi) / Color: 1200 x 1200 dpi, 4800 Color Quality (2400 x 600 dpi)
Memory	Standard: 512 MB / Maximum: 1536 MB
Recommended Monthly Page Volume <sup>4</sup>	3000 - 10000 pages
Maximum Monthly Duty Cycle: Up to <sup>5</sup>	100000 pages per month
<b>Copying</b>	
Copy Speed: Up to	Black: 35 cpm / Color: 35 cpm
Time to First Copy: As fast as	Black: 13 seconds / Color: 13.5 seconds
<b>Scanning</b>	
Scanner Type / ADF Scan	Flatbed scanner with ADF / RADF (Reversing Duplex)
Duplex Scan Speed: Up to	Black: 12 / 12 sides per minute / Color: 12 / 12 sides per minute
Simplex Scan Speed: Up to	Black: 34 / 35 sides per minute / Color: 33 / 35 sides per minute
<b>Faxing</b>	
Modem Speed	33.6 Kbps
<b>Supplies</b>	
Photoconductor Estimated Yield: Up to <sup>6</sup>	20,000 pages, based on 3 average letter/A4-size pages per print job and ~ 5% coverage
<b>Paper Handling</b>	
Paper Input Capacity: Up to	Standard: 650 pages 20 lb or 75 gsm bond / Maximum: 4300 (Add 3 of 550-Sheet Drawers and 2,000 Sheet High-Capacity Feeder on desk top or swivel cabinet) pages 20 lb or 75 gsm bond
Paper Output Capacity: Up to	Standard: 250 pages 20 lb or 75 gsm bond / Maximum: 250 pages 20 lb or 75 gsm bond
Media Types Supported	Card Stock, Envelopes, Paper Labels, Plain Paper, Transparencies, Vinyl Labels, Refer to the Card Stock & Label Guide.
Media Sizes Supported	10 Envelope, 7 3/4 Envelope, 9 Envelope, A4, A5, B5 Envelope, C5 Envelope, DL Envelope, B5, Executive, Folio, JIS-B5, Legal, Letter, Statement, Universal, Oficio, A6
<b>General Information</b>	
Standard Ports	USB 2.0 Specification Hi-Speed Certified (Type B), Front USB 2.0 Specification Hi-Speed Certified Port (Type A), Rear USB 2.0 Specification Hi-Speed Certified Port (Type A), Ethernet 10/100/1000 BaseTX (RJ-45)
Optional Network Ports / Optional Local Ports	Internal MarkNet™ N8120 Gigabit Ethernet, Internal MarkNet™ N8250 802.11b/g/n Wireless / Internal RS-232C serial, Internal 1284-B Bidirectional Parallel
Noise Level: Operating	Print: 57 dBA / Copy: 58 dBA / Scan: 54 dBA
Specified Operating Environment	Temperature: 16 to 32°C (60 to 90°F), Humidity: 8 to 80% Relative Humidity, Altitude: 0 - 3048 Meters (10,000 Feet)
Size (in. - H x W x D) / Weight (lb.)	31.0 x 21.5 x 24.5 in. / 97.5 lb.

<sup>1</sup>10,000\*-page color High Yield Toner Cartridges (CMY) <sup>2</sup>\*Yield at approximately 5% coverage per color <sup>3</sup>12,000\*-page Black High Yield Toner Cartridge <sup>4</sup>"Recommended Monthly Page Volume" is a range of pages that helps customers evaluate Lexmark's product offerings based on the average number of pages customers plan to print on the device each month. Lexmark recommends that the number of pages per month be within the stated range for optimum device performance, based on factors including: supplies replacement intervals, paper loading intervals, speed, and typical customer usage. <sup>5</sup>"Maximum Monthly Duty Cycle" is defined as the maximum number of pages a device could deliver in a month using a multishift operation. This metric provides a comparison of robustness in relation to other Lexmark printers and MFPs. <sup>6</sup>Actual Yield may vary based on other factors such as device speed, paper size and feed orientation, toner coverage, tray source, percentage of black-only printing and average print job complexity. <sup>7</sup>Average continuous black or continuous composite CMY declared cartridge yield up to this number of standard pages in accordance with ISO/IEC 19798. Actual yield may vary according to customer usage.