

Toner empty

☞ *User's Guide: Chapter 6*

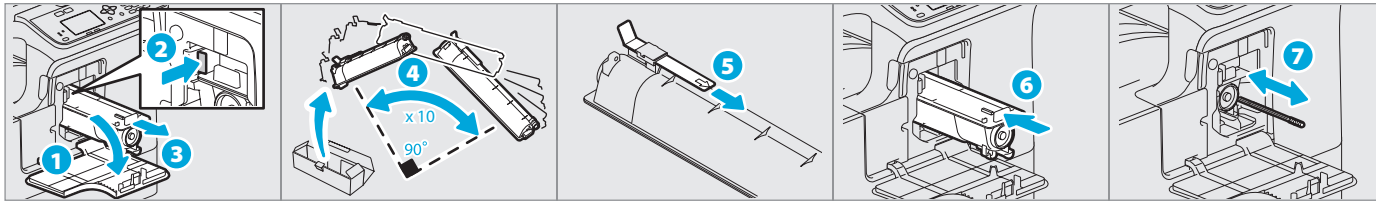

Paper misfeed

☞ *User's Guide: Chapter 6*

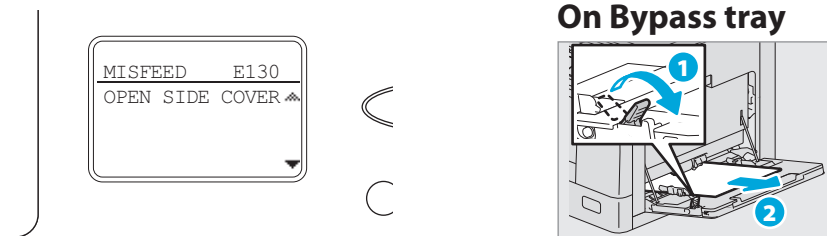

On Bypass tray

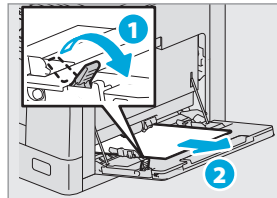

In Side cover

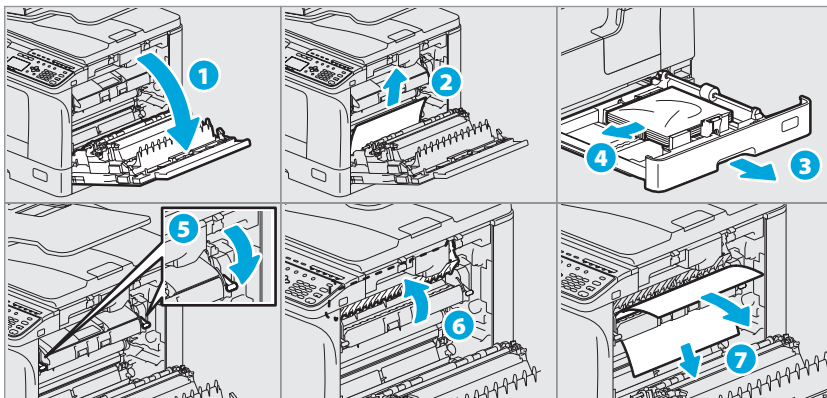

In RADF

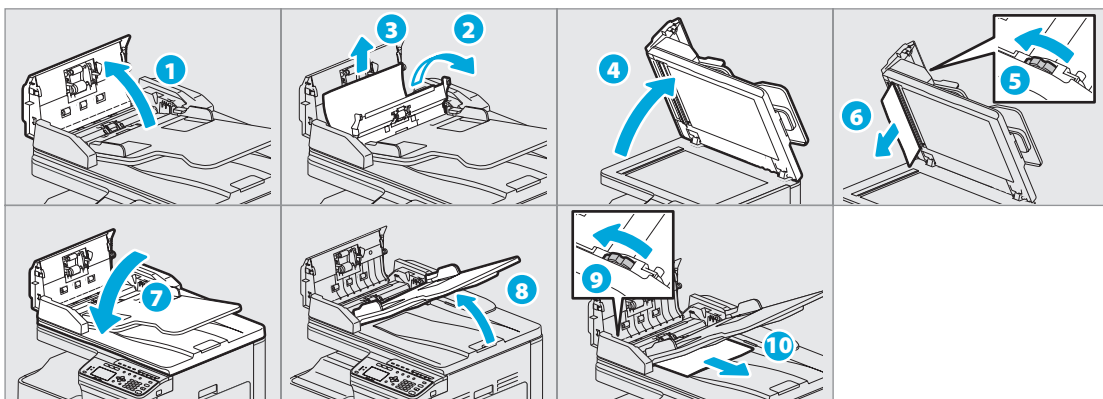

In PFU

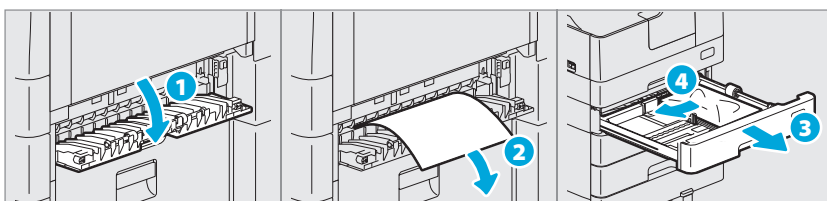

Quick Guide

This manual describes the components, preparations, basic operations, and troubleshooting for the equipment. **Before using the equipment, read the Safety Information (Printouts).** The DVD bundled with the equipment contains the User's Guide (PDF file) besides this guide.

Trademarks

Company names and product names in this manual are the trademarks of their respective companies.

Equipment

☞ *User's Guide: Chapter 1*

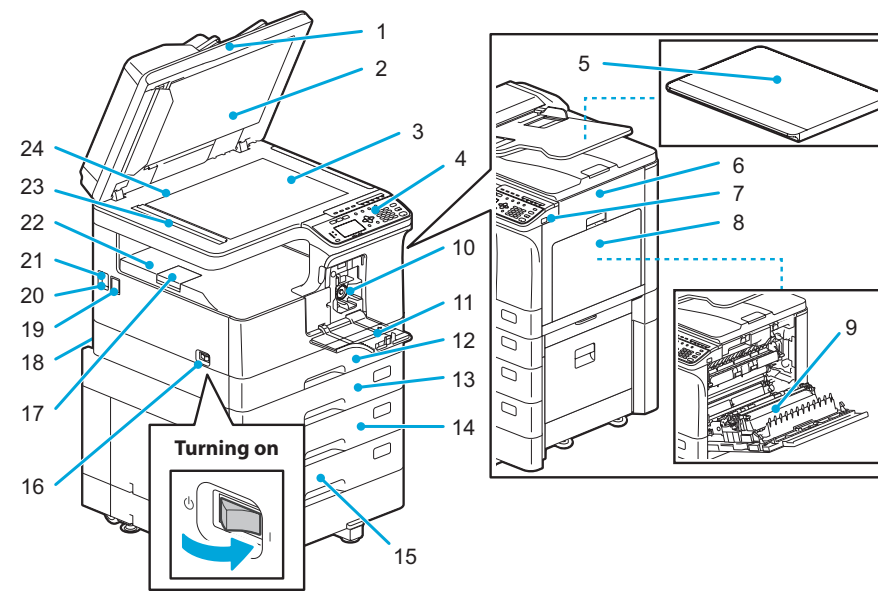

- | | |
|--|---------------------------------|
| 1. Reversing Automatic Document Feeder (RADF)* | 13. Paper Feed Unit (PFU)* |
| 2. Platen sheet | 14. Paper Feed Pedestal* |
| 3. Original glass | 15. Drawer Module* |
| 4. Control panel | 16. Power switch |
| 5. Platen Cover* | 17. Paper exit stopper |
| 6. Side cover | 18. AC-IN terminal (rear) |
| 7. USB port | 19. FAX port* |
| 8. Bypass tray | 20. Network interface connector |
| 9. Automatic Duplexing Unit* | 21. USB terminal (4-pin) |
| 10. Toner cartridge | 22. Receiving tray |
| 11. Front cover | 23. Scanning area |
| 12. Drawer | 24. Original scale |

Control panel

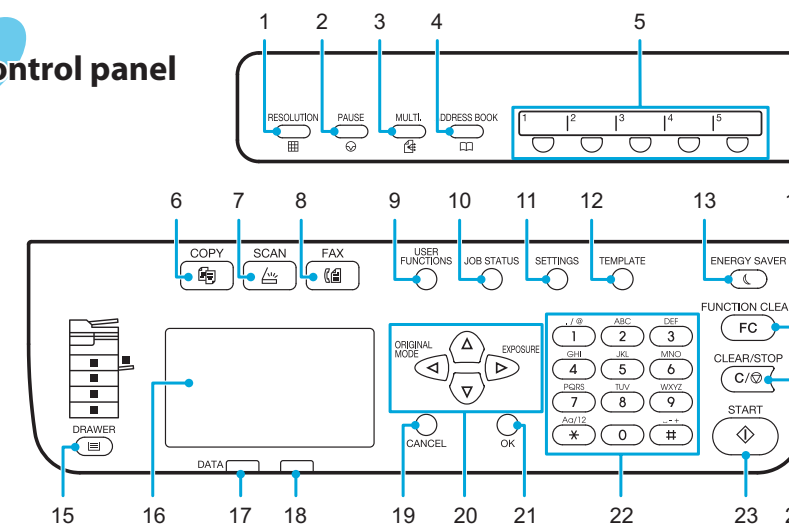

- | | |
|-------------------|--------------------|
| 1. RESOLUTION* | 13. ENERGY SAVER |
| 2. PAUSE* | 14. FUNCTION CLEAR |
| 3. MULTI.* | 15. DRAWER |
| 4. ADDRESS BOOK* | 16. LCD screen |
| 5. One Touch* | 17. DATA |
| 6. COPY | 18. Alert lamp |
| 7. SCAN | 19. CANCEL |
| 8. FAX | 20. Δ▽◀▶ |
| 9. USER FUNCTIONS | 21. OK |
| 10. JOB STATUS | 22. Digital keys |
| 11. SETTINGS | 23. START |
| 12. TEMPLATE | 24. CLEAR/STOP |

* optional

Before Use ▶

Loading paper

[User's Guide: Chapter 1](#)

Drawer

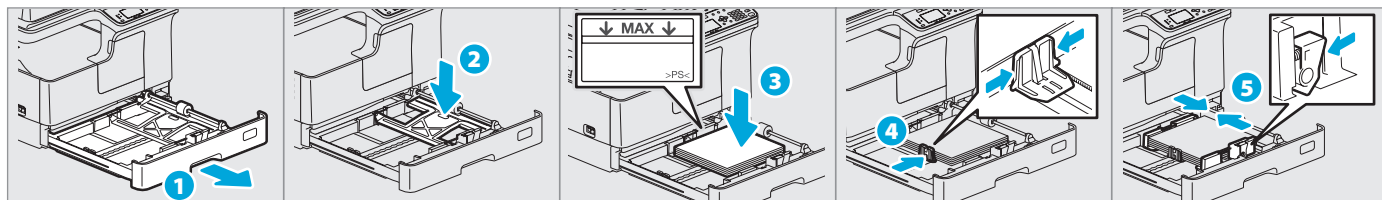

Bypass tray

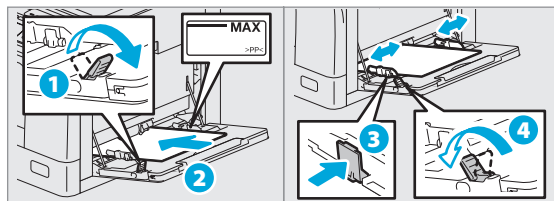

To set paper size of Drawer
When you load paper in the drawer, a pop-up window appears. Follow the instructions and set the paper size. (When the "POP UP" function is set to "ENABLE".)

Driver installation

[Software Installation Guide: Chapter 2](#)

Installing the driver requires the administrator authority. For Windows 7, Windows 8, Windows Server 2008 R2, or Windows Server 2012, use the installer.

Note when installing from installer

- Close all running applications.
- If the installer does not automatically start, double-click "Setup.exe" in the DVD.

Connecting computer

Before installing the drivers, connect the equipment and the computer with a USB cable or Network interface cable.

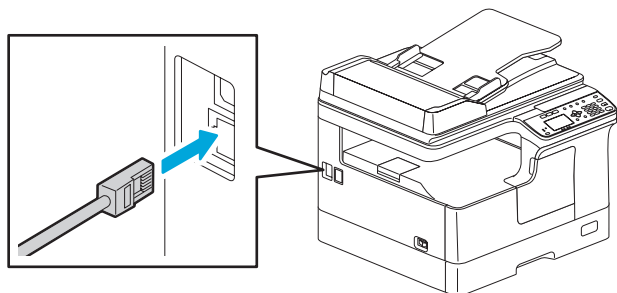
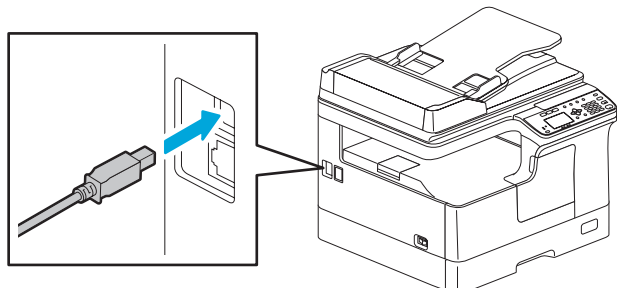

Using installer

1. Close all running applications.
2. When a USB cable is connected, make sure that the equipment is turned off.
3. Insert the DVD into the computer.
4. Double-click "Setup.exe".
5. Follow the on-screen instructions.

Printer and scanner functions are available.

Copier

[User's Guide: Chapter 2](#)

1. Place the original(s).

Original glass

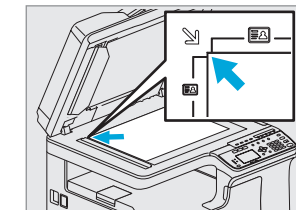

RADF

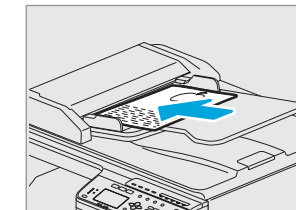

2. Press [COPY] and make the copy settings.



3. Enter the number of copies with the digital keys **1**, and then press [START] **2** to copy.

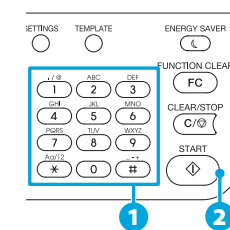

To stop copying
Press [CLEAR/STOP]

To reset settings and LCD screen after copying
Press [FUNCTION CLEAR]

Shortcut keys
Press **<**: "ORIGINAL MODE"
Press **>**: Europe and Americas "EXPOSURE", Except Europe and Americas "ID CARD"

Printer

[User's Guide: Chapter 3](#)

1. Select [Print] from the application's [File] menu.
2. Select your printer **1**, and then click [Preferences] **2**.
3. Make print option settings, and then click [OK].
4. Click [Print] ([OK]).

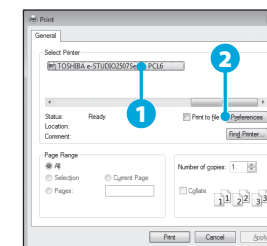

Scanner

[User's Guide: Chapter 4](#)

Scan to USB Memory

1. Place the original(s).
2. Press [SCAN].
3. Connect the USB storage device to the equipment and wait a few seconds.
4. Press **<** or **>** to select "USB", and then press [OK].
5. Press **>** to make the scan settings as required.
6. Press [START] to scan your documents.

TWAIN Scan

1. Place the original(s).
2. Launch a TWAIN-compliant application.
3. Select the device from the application's [File] menu.
4. Select the menu to scan from the application's [File] menu.
5. Make the scan settings, and then click [Scan].

Fax

[Fax Guide](#)

Connecting Cables

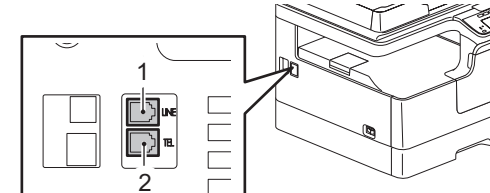

1. Line Connect a telephone line.
2. TEL Connect an external telephone.

Sending a Fax

1. Place the original(s).
2. Press [FAX].
3. Make settings for transmission conditions.
4. Specify the destination.
5. Press [START].

Registering an Address Book

1. Press [USER FUNCTIONS].
2. Select "ADDRESS BOOK" → "PHONE BOOK".
3. Make settings for "SPEED DIAL", "GROUP DIAL", and "ONE TOUCH", and then press [OK].