

## Installation Instructions Vertical (Board & Batten) Siding

These instructions describe and illustrate the steps involved in installing CertainTeed siding and trim. Their purpose is to provide detailed information and how-to tips that will simplify the installation process. CertainTeed shall not accept any liability or responsibility under its written warranty for failure caused by application that does not meet our minimum requirements for proper installation. These requirements are outlined throughout the *CertainTeed Installation Guide (CTS205)*. Any deviations from these requirements should be approved in writing by CertainTeed Corporation.

### Preparing Wall Surfaces

For the most part, the wall preparation instructions given for horizontal siding also apply to vertical applications. The key requirement, of course, is that you start with a **smooth, level and rigid substrate** (plywood, wood composite, rigid foam or fiber sheathing).

With vertical siding, however, you may have to complete an extra step to provide solid nailing points along the vertical edge of the siding panel. The need for this added step depends on the type of substrate used and the nature of the construction project.

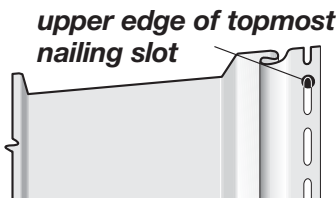

With new construction or remodeling using plywood or wood composite, there are no additional steps. You can nail into plywood and wood composite substrates at any point as long as you do not exceed 16" on center.

In new construction, using rigid foam or fiber sheathing, you must install solid wood nailer strips horizontally to studs **before** applying sheathing. Use 1 x 3 wood furring positioned 12" - 16" on center. **In high wind regions, including Texas, space the furring strips 12" on center. Check your local building codes.**

When remodeling over existing wood siding, you must apply rigid foam or fiber sheathing, shimming if necessary to create a level surface.

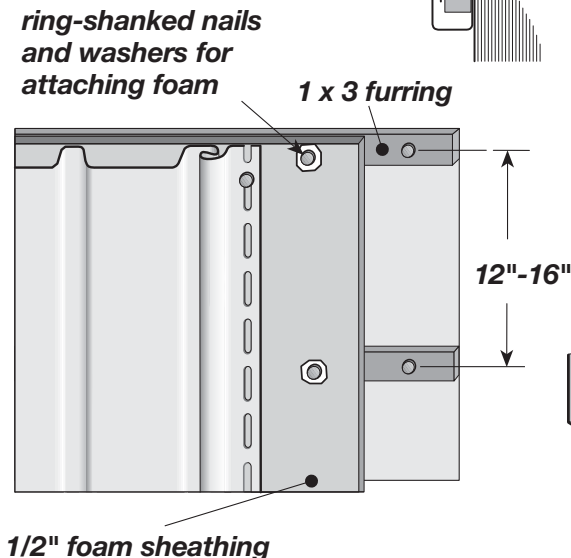

*always position topmost nail in topmost full nail slot with vertical applications*

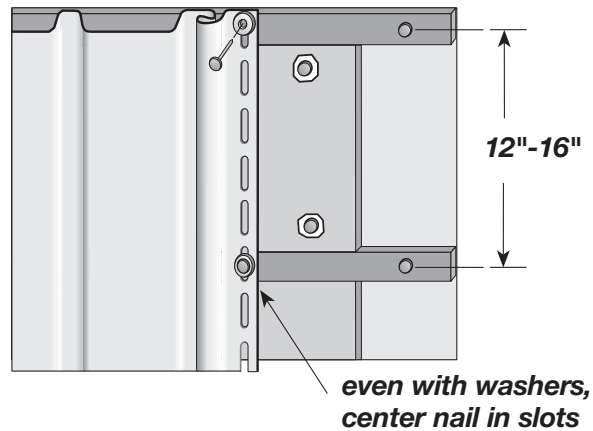

When remodeling over brick, block, stucco or irregular wall surfaces, apply furring strips **horizontally** to create a level surface, then apply rigid foam or fiber sheathing.

### Top and Bottom J-channel

Snap a base line 1" above the low point of the house. Apply J-channel along the top and bottom of the walls to receive the siding panels.

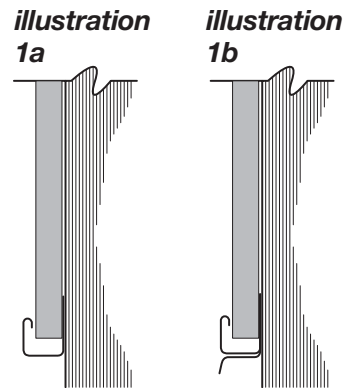

Install the bottom J-channel (illustration 1a). Overlap J-channels 3/4". To do this, cut out a 1" section of the nailing flange and face return (see illustration 2).

If you prefer to use drip flashing with the J-channel along the bottom of the wall, fabricate the lengths you'll need from aluminum coil stock of a color to match the siding (see illustration 1b).

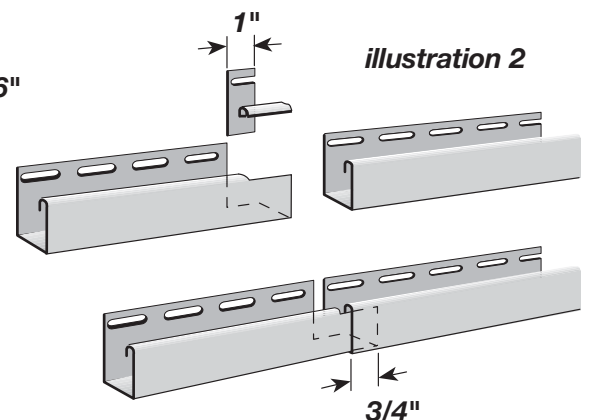

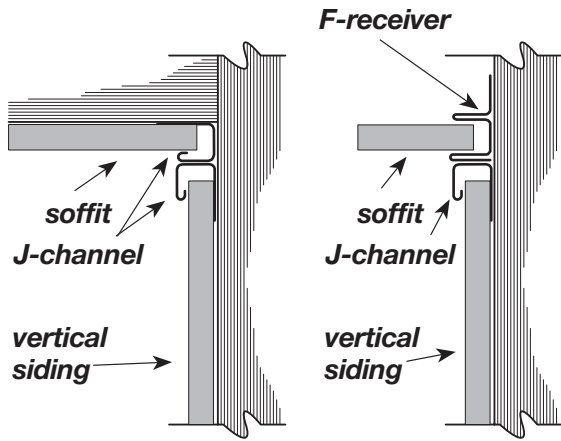

Install inverted J-channel along the top of the wall, under the eave. Here again, leave a 1/4" gap between J-channel and cornerposts. Overlap J-channels 3/4" to allow for expansion. When positioning the upper J-channel, be sure to allow for expansion of the siding panel. In most cases, position the J-channel at a point equal to the length of the panel plus 5/8" (1/4" for upper expansion and 3/8" for lower expansion).

### Soffit

If you're going to install soffit, you may want to install the receiving channels for the soffit at this point.

The illustrations show alternative approaches for installing siding and soffit receiving channels.

If a wall requires more than one course of siding, you can proceed in one of three ways:

Use two lengths of J-channel, back-to-back, at the joint between the two courses (illustration a).

Use a combination of one length of J-channel and one length of drip cap (illustration b).

Use a double channel lineal and flashing where required.

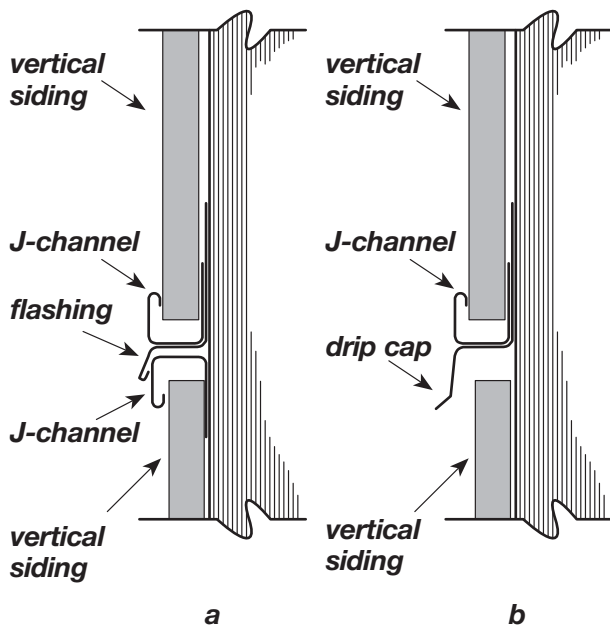

### If using J-Channel

Snap a chalk line parallel to the bottom J-channel, at a height equal to the length of the lower panel plus an allowance for expansion. For example, if the lower panel is 144" long and you're adding 1/2" for expansion (because the temperature is above 40° F), you strike a line 144-1/2" from the bottom J-channel. Nail inverted J-channels along this line to receive panels from below. Leave a 1/4" gap between J-channel and cornerposts. Overlap J-channels 3/4".

Prepare for the second course by applying head flashing above the just-installed J-channel. Then nail J-channel over the flashing to receive the upper panel.

**NOTE:** Some installers prefer to use formed aluminum flashing in place of vinyl drip cap as the receiving channel for the lower panel. This is also an acceptable approach.

### Installing J-channel at Gable Ends

**If using double channel lineal:** Measure the length of the lower panel, then add an allowance for expansion. Snap a chalk line parallel to the bottom J-channel, at a height equal to your measurement. Position the lineal so the interior peak of the lower channel runs along the chalk line. Nail.

Leave a 1/4" gap between lineal and cornerposts.

**aluminum flashing (required if lineals are overlapped) or provide additional means of flashing**

Where required, overlap lineals 1". Whenever lineals are overlapped, you must insert flashing into the upper channel, or provide additional means of flashing. Nail in place.

**double channel lineal**

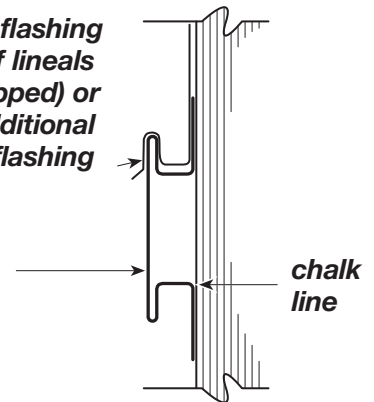

### Installing Window and Door Trim

To trim windows and doors, install J-channel along the top and sides of the door casings and around windows. If you are installing J-channel around replacement windows that do not have nail flanges, flash the window before you trim it. Also, for best results, use aviation snips when cutting the J-channel.

Before you begin to miter cut the corners, make sure the J-channel is cut to the proper length. Leave the proper allowance for the width of the face of the J-channel. Then:

1. Square cut the bottom J-channel so that its ends extend beyond the window casing to the width of the face of the J-channels.
2. Notch the ends for clearance.
3. Position and fasten the bottom J-channel.

4. Measure the side J-channels. Add the width of both the top and bottom J-channels.
5. Miter cut (45°) the lower ends of both side J-channels.
6. Notch the channels, position them, and fasten the side J-channels.
7. Mark the top J-channel so its ends extend beyond the casing to the width of the side J-channels.
8. Miter cut the channel ends.
9. Cut and bend water tabs on the top J-channel.
10. Position and fasten the top J-channel.

## Installing Wall Panels

Correctly installed vertical siding should have a balanced appearance. This means that if you were to draw a vertical line down the center point of a wall, you'd have an equal number of panels to the right and left. If you had to trim panels to fit, the end-most panels would be of identical width.

To create this pleasing appearance, divide the space to be covered by a partial panel over both ends of a wall. For example, if a wall required 25 full panels plus 10", you would rip cut two 5" lengths of panel to create the end pieces.

## Expansion and Contraction

In a vertical siding installation, most of the expansion is downward. So instead of allowing equal space for expansion at both ends of a vertical panel, leave more space at the lower end: allow for 1/3 of the total expansion at the top of a panel and 2/3 of the total expansion at the bottom.

For example, if the total expansion equals 3/4" (3/8" + 3/8"), allow 1/4" at the top and 1/2" at the bottom.

Always position the top most nail at the top of the top most full nail slot (2a). Center the remaining nails in the slots (2b).

Cut the first of the partial panels (if partial panels are necessary). Mark the cut line by measuring from the nail hem edge. Rip cut the panel. Do not cut off the nail hem. Use a snap lock punch to create locking tabs along the cut edge. Space the tabs 6" apart.

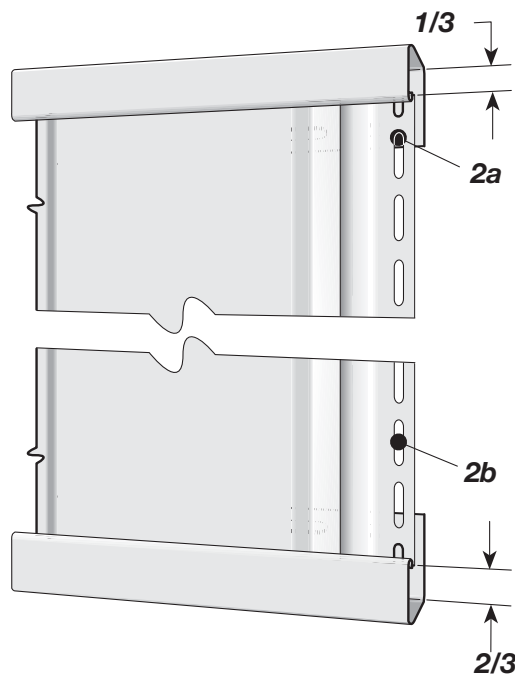

Before installing this partial panel into the outside cornerpost, provide additional support at the cut edge (to compensate for the locking channel that was trimmed off).

To do this, insert furring into the channel of the outside cornerpost and nail it to the substrate. After furring, insert a length of undersill trim into the cornerpost and nail it to the furring. Finally, slide the cut edge of the panel into the undersill trim, making sure to engage the snap locks.

Using a level, make certain this panel is plumb. Nail every 12".

Install the next panel. Lock the panel into the preceding panel, then nail every 12". Continue with succeeding panels.

When necessary, cut panels to fit around doors and windows. When marking the cut, remember to allow for expansion.

The method used to install panels around doors and windows is determined by the need to cut a panel and the position of that cut.

If a cut was made next to a remaining V-groove, insert the panel into the J-channel.

If a cut removes the support provided by a V-groove, use the procedure described above to provide support for the trimmed edge.

To finish the first course of a wall, cut the final panel to size and install it in an outside cornerpost, using the method described above.

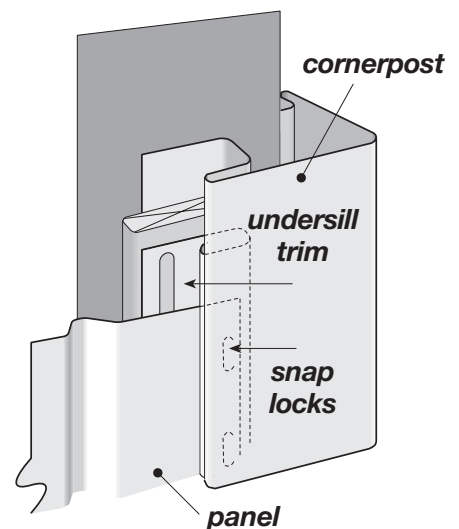

**NOTE:** The cutting and supporting procedure described above is also used when fitting panels into inside cornerposts.

If you have any questions about installing this product, please call us at 800-233-8990.