

Q181A Auxiliary Potentiometer

INSTALLATION INSTRUCTIONS



APPLICATION

The Q181A Auxiliary Potentiometer controls one or two Series 90 auxiliary motors from one master motor. It mounts directly on the master motor and will operate the controlled motors in unison or in sequence. The Q181A is adjustable to give full motor travel for 40 to 160 degrees of master motor shaft rotation.

- Controls one or two Modutrol motors.
- Easy installation on master motor.
- Provides unison or sequential operation.
- Throttling range adjustable from 40 to 160 degrees.
- Permits positioning auxiliary motors with the master motor.

ORDERING INFORMATION

When purchasing replacement and modernization products from your TRADELINE® Wholesaler or your distributor, refer to the TRADELINE Catalog or price sheets for complete ordering number, or specify—

1. Model number.
2. Number and model of motors to be used with.
3. Accessory, if desired.

If you have additional questions, need further information, or would like to comment on our products or services, please write or phone:

SPECIFICATIONS

MODEL

Q181A Auxiliary Potentiometer—controls one or two auxiliary motors in unison or in sequence from a master motor. For use with Series 90 Modutrol motors.

THROTTLING RANGE

Adjustable from 40 to 160 degrees on each potentiometer.

STARTING POINT OF CONTROLLED MOTORS

Adjustable from 0 to 120 degrees of master motor travel. Sum of values of starting point and throttling range should not exceed 160 degrees.

MOUNTING

Mounts directly on master motor. Refer to Fig. 1 and 2.

DIMENSIONS

(in inches) 3-3/16 high, 3-1/4 wide, and 3-3/8 deep.

FINISH: Gray enamel.

1. Your local Honeywell Home and Building Control Sales Office (check white pages of your phone directory).
2. Home and Building Control Customer Satisfaction Honeywell Inc., 1885 Douglas Drive North Minneapolis, Minnesota 55422-4386 (612) 951-1000

In Canada—Honeywell Limited/Limitee, 740 Ellesmere Road, Scarborough, Ontario M1P 2V9. International Sales and Services Offices in all principal cities of the world. Manufacturing in Australia, Canada, Finland, France, Germany, Japan, Mexico, Netherlands, Spain, Taiwan, United Kingdom, U.S.A.



INSTALLATION

CAUTION

Disconnect power supply before beginning the installation to prevent electrical shock or equipment damage. Only a trained, experienced service technician should install or service this control. The Q181 must be connected only in a low voltage series 90 Modutrol motor control circuit.

LOCATION

The Q181 Auxiliary Potentiometer may be mounted on either end of a Modutrol Motor. It may be used with either a spring return or non-spring return motor.

MOUNTING

1. The two-piece coupling provides a nonbinding connection between the motor drive shaft and the drive pin on the Q181A (see Fig. 3). Place the shaft coupling on the motor shaft so the slots are on the top and bottom when the motor is in the closed position (controller R-W contacts are closed). Tighten both set screws securely.

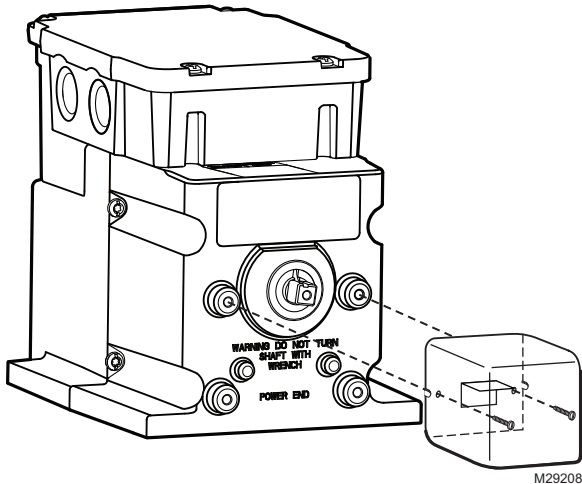

Fig. 1. Mounting the Q181 on M9185 or M9186 style modutrol motor, or any motor with bosses.

2. Make certain that the cam follower is on the low side of the cam, as shown in Fig. 5. Fit the drive pin coupling over the drive pin and put the Q181A in place on the master motor. The drive pin shaft should engage the shaft coupling.

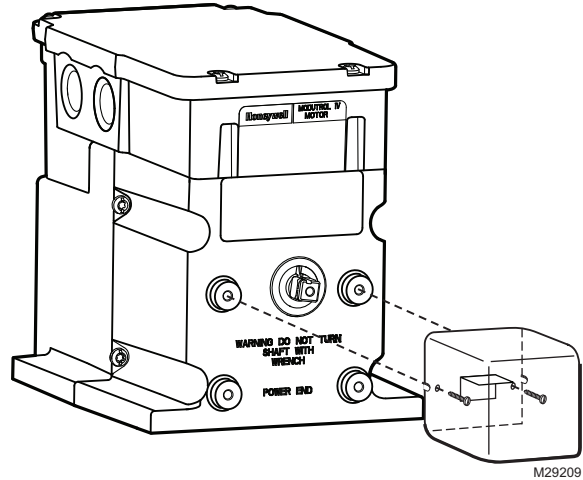

Fig. 2. Mounting the Q181 on M9184 style modutrol motor, or any motor with bosses.

3. Mount the Q181 on the motor. The two mounting holes in the Q181 line up with the two mounting holes on the end of the motor, horizontally in line with the shaft. Mounting screws may be held in the back of the case with the fiber washers during installation. See Fig. 1 and 2.

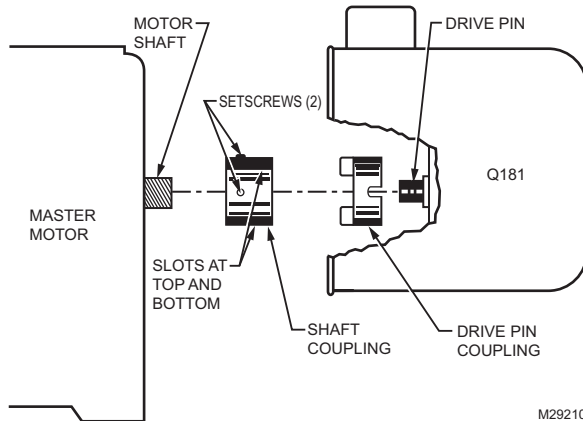

Fig. 3. Two-piece coupling for motor and potentiometer.

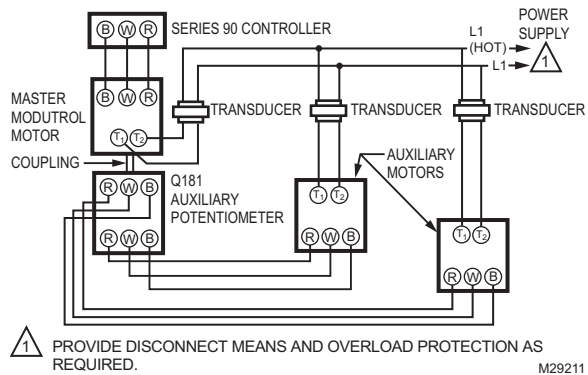

Fig. 4. Typical hookup of Q181, Two potentiometer model, and two auxiliary motors.

WIRING

Bring the wires into the Q181A through the conduit outlet in the top, down and forward to the wiring panels provided (see Fig. 4 and 5). Terminals are marked R, W, and B.

CAUTION

Disconnect power supply before connecting wiring to avoid electrical shock and equipment damage.

All wiring must comply with local codes, ordinances, and regulations.

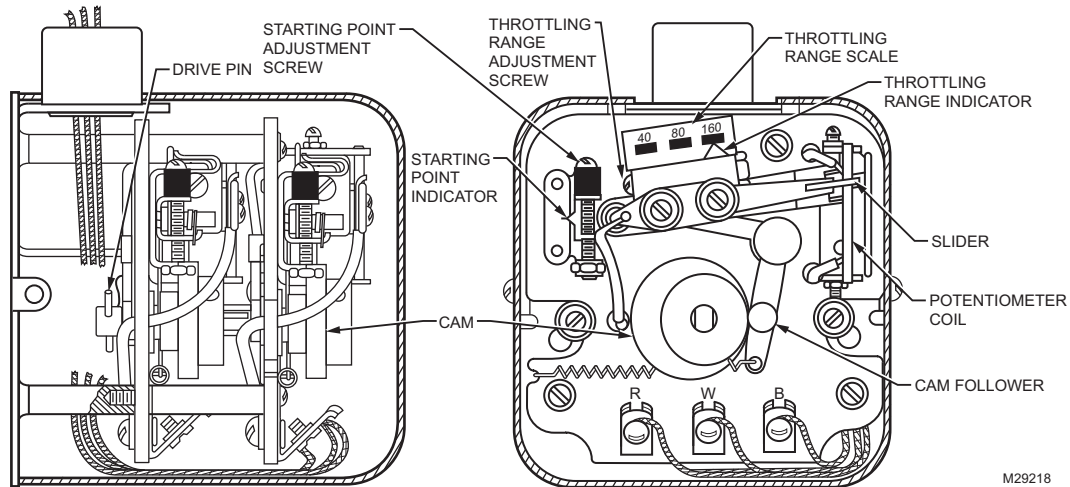

Fig. 5. Internal view of a two potentiometer Q181.

SETTINGS

The following settings determine operation of the Q181A. The sum of the starting point and throttling range values should not exceed 160 degrees.

When installing models with two potentiometers, follow the same procedure to adjust each potentiometer.

STARTING POINT

The point in the rotation of the master motor at which the auxiliary motor starts its travel in one direction or completes its travel on the return stroke. The starting point is determined by the starting point adjustment screw (see Fig. 5) and is adjustable between 0 and 120 degrees.



THROTTLING RANGE

The rotation on the master motor required to drive the Q181A potentiometer through its full travel, which in turn drives the auxiliary motor through its full travel. The throttling range is determined by the throttling range adjustment screw (see Fig. 5) and is adjustable from 40 to 160 degrees of the master motor rotation.

NOTE: Do not set either adjustment screw closer than 1/4 turn from either stop.

OPERATION AND CHECKOUT

UNISON OPERATION

1. Connect a manual 135 ohm potentiometer to terminals R, B, and W of the master motor. (This connection takes the place of the controller.) Set the starting point and the throttling range to match the master motor rotation.
2. Power the system and run the master motor through its full rotation in both directions. The auxiliary motor should run through its full stroke in each direction.
3. If the auxiliary motor does not run through its stroke each way in unison with the master motor, make these adjustments:
 - a. Turn the throttling range adjustment screw (Fig. 5) slightly clockwise . The indicator should move slightly to the left on the scale. This shortens the throttling range so that the auxiliary motor will open fully.
 - b. Turn the starting point adjustment screw slightly counterclockwise . The indicator should move slightly downward. This assures that the auxiliary motor will fully close in unison with the master motor.
4. Repeat Step 2 and readjust if necessary. Check both adjustments after changing either setting. Disconnect the manual potentiometer and reconnect the system controller.

SEQUENCE OPERATION

To obtain full auxiliary motor rotation with less than full rotation of the master motor, use the following procedure:

1. Turn the throttling range adjustment screw (Fig. 5) until the indicator is positioned properly on the scale.
2. Connect a manual potentiometer to terminals R, B, and W of the master motor in place of the system controller. Power the system.
3. Run the master motor fully open and fully closed, noting the point at which the auxiliary motor starts and completes its stroke. Readjust the throttling range adjustment screw if necessary.
4. For a longer interval between the starting point of the master motor and that of the auxiliary motor, turn the starting point adjustment screw counterclockwise . The indicator should move down the scale. Repeat Step 3. Check and readjust if necessary.
5. For a shorter interval between the starting point of the master motor and starting point of the auxiliary motor, make these adjustments:
 - a. One auxiliary motor: Loosen the setscrews and rotate the cam 180 degrees on its shaft. Reverse the B and W leadwires and tighten the setscrews. Repeat step 3. Check and readjust if necessary.
 - b. Two auxiliary motors: Dismount the Q181A from its master motor and turn the drive pin 180 degrees, leaving the setscrews tight. This will reverse both cams. Mount the Q181A and reverse the B and W leadwires. Repeat Step 3. Check and readjust if necessary.
6. To check the starting point and throttling range settings, run the master motor through a complete cycle and observe the operation of the auxiliary motor(s). Check both adjustments after changing either setting. Disconnect the manual potentiometer and reconnect the system controller.

By using this Honeywell literature, you agree that Honeywell will have no liability for any damages arising out of your use or modification to, the literature. You will defend and indemnify Honeywell, its affiliates and subsidiaries, from and against any liability, cost, or damages, including attorneys' fees, arising out of, or resulting from, any modification to the literature by you.

Automation and Control Solutions

Honeywell International Inc.
1985 Douglas Drive North
Golden Valley, MN 55422
customer.honeywell.com

Honeywell Limited-Honeywell Limitée
35 Dynamic Drive
Toronto, Ontario M1V 4Z9

