



Technical Data	
Service	chilled or hot water and steam
Applicable valve size	½" [13], ¾" [19], 1" [25], 1-¼" [32], 1-½" [38], 2" [50]
Stem	slotted, threaded
Frame, plate, base	aluminum, steel
Collar	aluminum, steel, (fits bonnets up to 1.7" dia.)
Stem adaptor	aluminum
Stroke	0.6" [15 mm] LVK, 0.75" [20 mm] SVK
Mounting position	360°
Media temp range (water)	20°F to 250°F [-7°C to +120°C]
Media temp range (steam)	32°F to 388°F [0°C to 170°C]
Weight	1.9 lbs

### Application

The UGVL retrofit kit is designed to easily attach LV and SV series actuators to select globe valves. Its unique adjustable design allows the UGVL to be mounted on ½" to 2" two-way or three-way valves in both normally open and normally closed configurations.

### Default/Configuration

The default set up for a UGVL linkage will be factory installed along with a LV or SV series actuator. Included in the kit will be all the necessary hardware to facilitate mounting to the valve.

### Operation

The UGVL linkage with actuator will provide 20 mm of linear travel to accommodate a wide range of valves.

### Suitable Actuators

Linkage	Non-Spring Return	Electronic Fail-Safe
UGVL	LV, SV	LVK, SVK

### Dimensions (Inches [mm]) with LV and SV Series Actuators

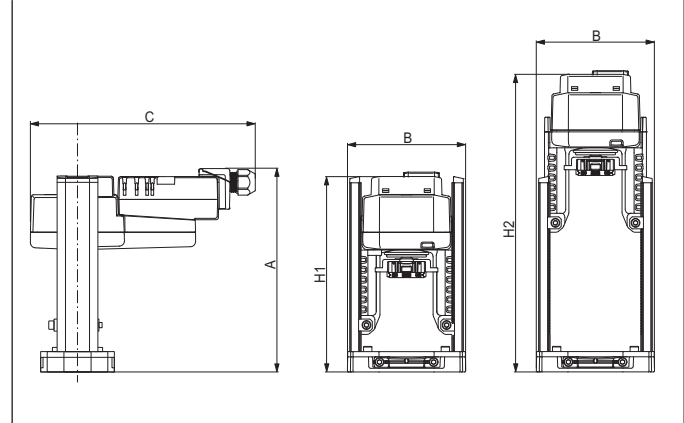

A	B	C	H1	H2
8" [203.2]	4.4" [113]	8.60" [218]	7.5" [190]	11.4" [290]

### Dimensions (Inches [mm]) with LVK and SVK Series Actuators

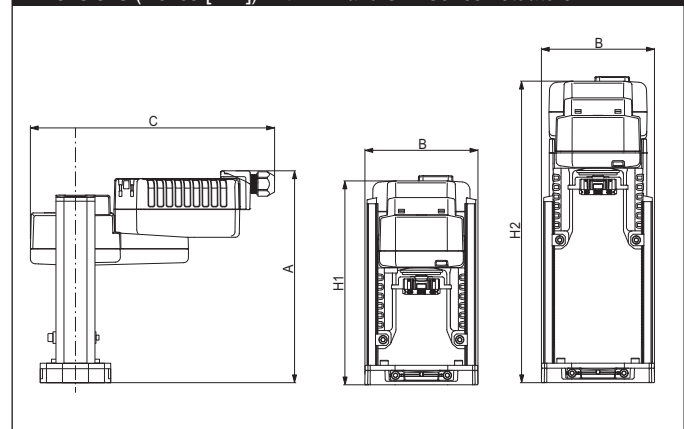

A	B	C	H1	H2
8.5" [217]	4.4" [113]	9.6" [244]	8.4" [207]	12.1" [307]

### Application Notes

\*\*Consult pages 93-119 of the Retrofit Technical Documentation and/or SelectPro for close-off pressures and a cross reference of each valve.

# SVKX24-SR

Proportional, Electronic Fail-Safe, Linear, 24 V, for 2 to 10 VDC or 4 to 20 mA



Technical Data	
Power supply	24 VAC $\pm$ 20% 50/60 Hz, 24 VDC $\pm$ 10%
Power consumption running	8.5 W
Power consumption holding	2.5 W
Transformer sizing	21 VA (class 2 power source)
Electrical connection	3 ft, 18 GA plenum rated cable with 1/2" conduit connector protected NEMA 2 (IP54)
Overload protection	electronic throughout full stroke
Electrical protection	actuators are double insulated
Control	2-10 VDC
Operating Range Y	2 to 10 VDC, 4 to 20 mA (default)
Input impedance	100 k $\Omega$ for 2 to 10 VDC (0.1 mA), 500 $\Omega$ for 4 to 20 mA
Feedback Output U	2 to 10 VDC
Stroke	0.75" [20 mm]
Linear Force	337 lbf [1500 N]
Direction of rotation	reversible with switch
Position indication	stroke indicator on bracket
Manual override	4 mm hex crank (shipped with actuator)
Running time motor	90 seconds (default), variable (90 to 150 seconds)
Running time fail-safe	35 seconds
Humidity	5 to 95% RH non condensing
Ambient temperature	-22°F to +122°F [-30°C to +50°C]
Storage temperature	-40°F to +176°F [-40°C to +80°C]
Housing	NEMA 2, IP54, UL enclosure type 2
Housing material	Aluminum die cast and plastic casing
Bridge Time	2 second delay before fail-safe activates
Initial Charge	5 to 20 seconds
Agency listings†	cULus acc. to UL 60730-1A/-2-14, CAN/CSA E60730-1:02, CE acc. to 2004/108/EC and 2006/95/EC
Noise level	<45dB(A)
Servicing	maintenance free
Quality standard	ISO 9001
Weight	3.6 lbs

† Use flexible metal conduit. Push the Listed conduit fitting device over the actuator's cable to butt against the enclosure. Screw in conduit connector. Jacket the actuators input wiring with Listed flexible conduit. Properly terminate the conduit in a suitable junction box. Rated impulse Voltage 800V. Type of action 1. Control Pollution Degree 3.

## Application

For fail-safe, proportional modulation of globe valves in HVAC steam and hydronic systems.

Actuator sizing will be dictated by the valve size selection. All valve selections should be done in accordance with the flow parameters and system specifications. The actuator is mounted directly to the globe valve bonnet by means of its universal clamp and collar.

The actuator operates in response to a 2 to 10 VDC, or with the addition of a 500  $\Omega$  resistor, a 4 to 20 mA control input from an electronic controller or positioner. A 2 to 10 VDC feedback signal is provided for position indication.

## Operation

The actuator is not provided with and does not require any limit switches, but is electronically protected against overload. The SVK series provides 20 mm of downward travel and a visual indicator indicates position of the actuator. When reaching the valve end position, the actuator automatically stops. The gears can be manually disengaged with a button on the actuator cover.

The SVK... series actuators use a sensorless brushless DC motor. The ASIC inside monitors and controls the actuator's rotation and provides a digital rotation sensing (DRS) function to prevent damage to the actuator in a stall condition. Power consumption is reduced in holding mode.

Add-on auxiliary switches are easily fastened directly onto the actuator body for signaling and switching functions. -SR and -MFT models will have an illuminated green Adaption/Power button to reset and relearn the valve stroke as well as indicate the actuator is powered. This feature allows the actuator to rescale itself based on the actual travel.

### Fail-Safe Indication

Green LED status indicator light sequence:

On: operation ok, no faults

Blinking: fail-safe mechanism is active

Off: fault is detected or not in operation / capacitors charging

## Dimensions (Inches [mm])

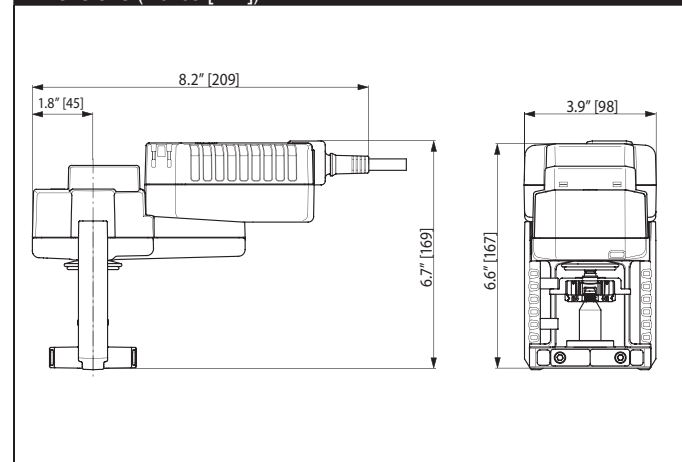

PT10401 - 01/13 - Subject to change. © Belimo Aircontrols (USA), Inc.

### Typical Specification

Proportional control globe valve actuators shall be electronic and direct coupled to the globe valve bonnet via an integrated linkage, which requires no secondary linkage and be capable of mounting to valves ½" to 2" in size. Actuators must provide control in response to a control input from an electronic controller or positioner. Actuators shall have brushless DC motor technology and be protected from overload at all angles of rotation. Actuators shall have reversing switch and manual override on the cover. Run time shall be constant and independent of torque. Actuators shall be cULus listed, have a 5-year warranty, and be manufactured under ISO 9001 International Quality Control Standards. Actuators shall be as manufactured by Belimo.

### Wiring Diagrams

#### ✂ **INSTALLATION NOTES**

- 3 Actuators may also be powered by 24 VDC.
- 5 Only connect common to neg. (-) leg of control circuits.
- 7 A 500Ω resistor converts the 4-20 mA control signal to 2-10 VDC.
- 18 Actuators with plenum cable do not have numbers; use color codes instead.
- ◆ Meets cULus or UL and CSA Standard requirements without the need of an electrical ground connection.

#### ⚠ **WARNING Live Electrical Components!**

During installation, testing, servicing and troubleshooting of this product, it may be necessary to work with live electrical components. Have a qualified licensed electrician or other individual who has been properly trained in handling live electrical components perform these tasks. Failure to follow all electrical safety precautions when exposed to live electrical components could result in death or serious injury.

