

Flowrite™ VF 599 Series Rack & Pinion Valves

Product Description

These installation instructions describe the steps for mounting the Flowrite VF 599 Series Rack & Pinion Valves (Figure 1), including the:

- linkage and actuator assembly
- linkage only

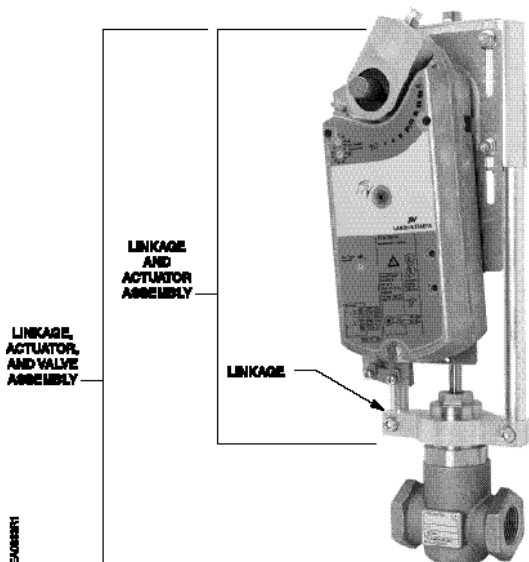

Figure 1. Parts of the Flowrite VF 599 Series Rack & Pinion Valve.

Product Numbers

Product Number	Description
599-03610	Linkage only
599-03609	Linkage and OpenAir™ GCA161.1U Electronic Actuator (298) assembly for modulating control
599-03611	Linkage and OpenAir GCA121.1U Electronic Actuator (299) assembly for 2-position control
298-XXXXX 299-XXXXX	Linkage, actuator, and valve assembly. (See TB249, Flowrite 599 Series Valve and Actuator Assembly Selection Technical Bulletin, 155-304P25 for details and product numbers.)

Warning/Caution Notations

WARNING		Personal injury/loss of life may occur if you do not perform a procedure as specified.
CAUTION		Equipment damage or loss of data may occur if you do not follow a procedure as specified.

Required Tools

- 3 mm hex wrench
- 5 mm hex wrench
- 1/4-inch Allen wrench
- 7/16-inch open end wrench
- 10 mm (13/32-in.) open end wrench
- No. 2 Phillips screwdriver

Expected Installation Time

30 minutes: Linkage and actuator assembly to valve (preload time included)

Prerequisites

The actuators are preloaded at the factory. If the actuator preload is lost, the preload must be reset according to the *Preload the Actuator* section.



WARNING:

Do not open the actuator.

Mounting the Linkage on a Valve

1. For new valves, remove the cap from the valve stem. See Figure 2.

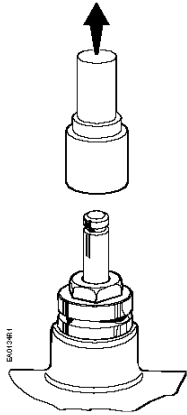

Figure 2. Preparing a New Valve for Installation.

2. Use the 5 mm hex wrench to loosen the nuts in the linkage stem coupling. Use the 1/4-inch Allen wrench to loosen the nuts in the linkage yoke. See Figure 3.

NOTE: Do not remove the nuts in the linkage stem coupling or in the linkage yoke.

3. Orient the linkage over the valve bonnet. See Figure 3.
4. Align the valve stem with the linkage stem coupling. See Figure 4.
5. Insert the valve stem into the linkage stem coupling. See Figure 4.
6. Use the 5 mm hex wrench to tighten the stem coupling screws and to secure the connection to the valve stem. See Figure 5.

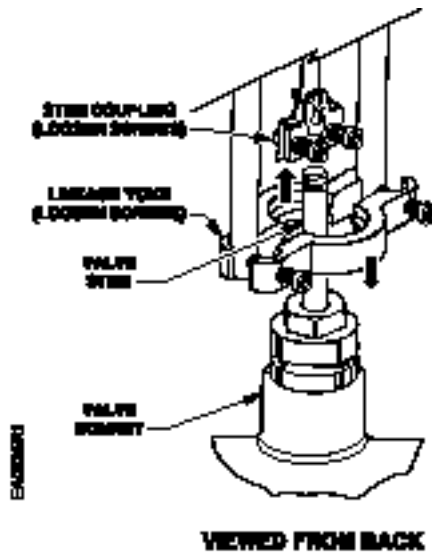

Figure 3. Mounting the Linkage/Actuator Assembly on a Valve.

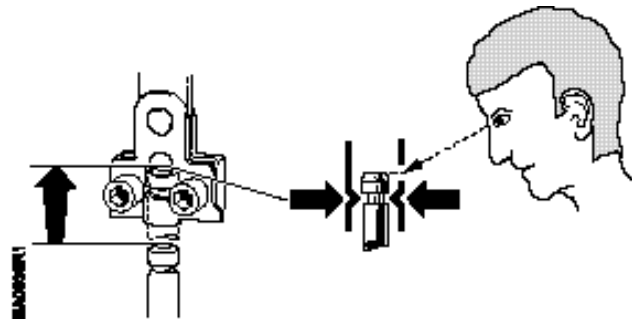

Figure 4. Proper Alignment of the Valve Stem to the Linkage Stem Coupling.

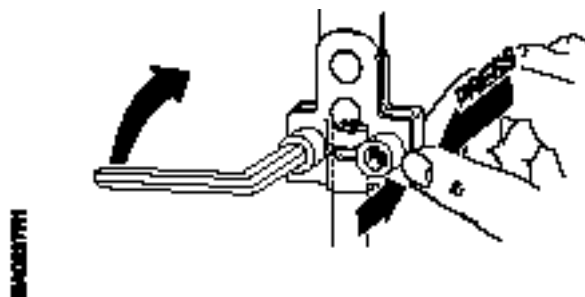

Figure 5. Connecting the Linkage Stem Coupling on the Valve Stem.

- Use the 1/4-inch Allen wrench to tighten the nuts in the linkage yoke and to secure the linkage on the valve bonnet. See Figure 6.

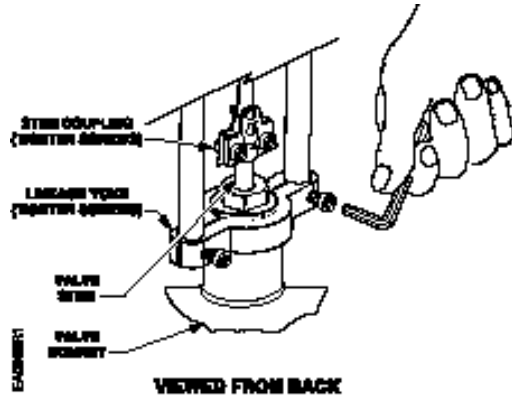

Figure 6. Connecting the Linkage Assembly on the Valve.

Assemble Actuator to the Linkage

- Determine if direct-acting or reverse-acting control is needed.
- Proceed with the *Direct-Acting Control Applications* or *Reverse-Acting Control Applications* section as appropriate.

Direct-Acting Control Applications (Figure 7)

- Orient the actuator so that the single end-stop tab is at the upper left and the gear train lockpin is on the right side.
- Align the actuator over the linkage shaft and insert the anti-rotation piece into the notched mounting hole on the back of the actuator.
- Loosen the shaft adapter locking screw (if necessary). With the valve stem full up, engage the shaft adapter spline into the actuator spline so that the left side of the adapter is aligned with the preload mark.

NOTE: The valve stem is up if the distance between the bottom of the linkage stem coupling and the top machined surface of the valve bonnet is 1.80 inches (46 mm) minimum. See Figure 12.

- At the back side of the actuator, insert the shaft adapter clip to secure the shaft adapter to the actuator.
- Continue with the *Preload the Actuator* section.

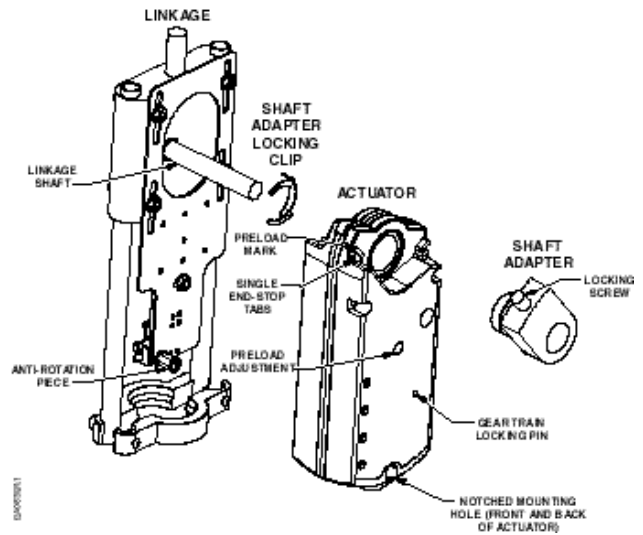

Figure 7. Mounting Actuator on Linkage for Direct-Acting Control Application.

Reverse-Acting Control Applications (Figure 8)

- Orient the actuator so that the single end-stop tab is at the upper right and the gear train lockpin is on the left side.
- Align the actuator over the linkage shaft and insert the anti-rotation piece into the notched mounting hole on the back of the actuator.
- Loosen the shaft adapter locking screw (if necessary). With the valve stem full up, engage the shaft adapter spline into the actuator spline so that the right side of the adapter is aligned with the preload mark.

NOTE: The valve stem is up if the distance between the bottom of the linkage stem coupling and the top machined surface of the valve bonnet is 1.80 inches (46 mm) minimum. See Figure 10.

- At the back side of the actuator, insert the shaft adapter clip to secure the shaft adapter to the actuator.
- Continue with the *Preload the Actuator* section.

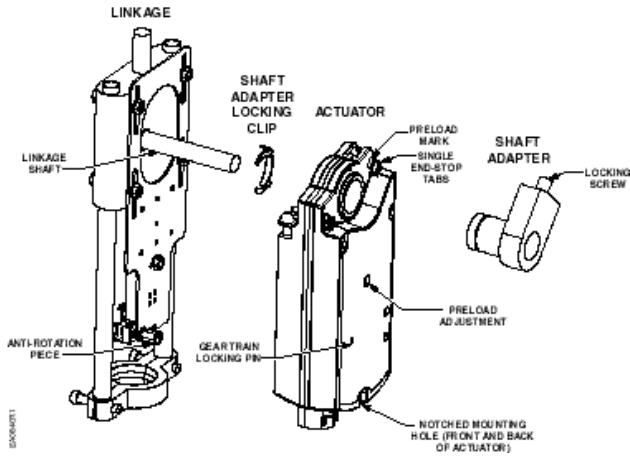

Figure 8. Mounting Actuator on Linkage for Reverse-Acting Control Application.

Preload the Actuator

NOTE: The actuators are preloaded at the factory. If the actuator preload is lost, the preload can be reset using the following instructions.

Direct-Acting Control Application with a Normally Closed, Normally Open, or Three-Way Valve

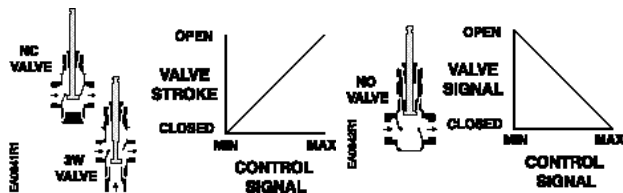

Figure 9.

1. Raise the valve stem to the full UP position.

NOTE: The valve stem is up if the distance between the bottom of the linkage stem coupling and the top machined surface of the valve bonnet is 1.80 inches (46 mm) minimum.

With the shaft adapter locking screw loose, insert the 3 mm hex key in the preload adjustment (Figure 7).

2. Preload the actuator by turning the hex key CW a full turn so the shaft adapter advances properly. Hold the hex key in place.

NOTE: Always turn the hex key in the direction of the actuator hand symbol arrow.

3. Engage the gear train lockpin using the Phillips screwdriver to turn only about 5 degrees until you hear a click or meet slight resistance.



CAUTION:

When you engage the gear train lockpin, turning too far will strip the lockpin.

4. Use a 10 mm (13/32 in.) open end wrench to tighten the shaft adapter locking screw.
5. Unlock the hex key by pushing slightly in the direction of the arrow. The preload is now set.
6. Remove the 3 mm hex key from the preload adjustment.

Reverse-Acting Control Application with a Normally Closed, Normally Open, or Three-Way Valve

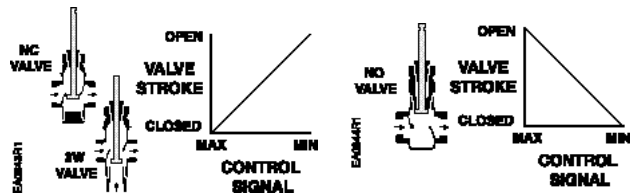

Figure 10.

1. Raise the valve stem to the full UP position.

NOTE: The valve stem is up if the distance between the bottom of the linkage stem coupling and the top machined surface of the valve bonnet is 1.80 inches (46 mm) minimum.

2. With the shaft adapter locking screw loose, insert the 3 mm hex key in the preload adjustment (Figure 8).
3. Preload the actuator by turning the hex key CCW a full turn so the shaft adapter advances properly. Hold the hex key in place.

NOTE: Always turn the hex key in the direction of the actuator hand symbol arrow.

- Engage the gear train lockpin using the Phillips screwdriver to turn only about 5 degrees until you hear a click or meet slight resistance.



CAUTION:

When you engage the gear train lockpin, turning too far will strip the lockpin.

- Use a 10 mm (13/32 in.) open end wrench to tighten the shaft adapter locking screw.
- Unlock the hex key by pushing slightly in the direction of the arrow. The preload is now set.
- Remove the 3 mm hex key from the preload adjustment.

Installation

Mount the Linkage/Actuator/Valve Assembly per Figure 10 and in the location per job drawings.

Installation is complete.

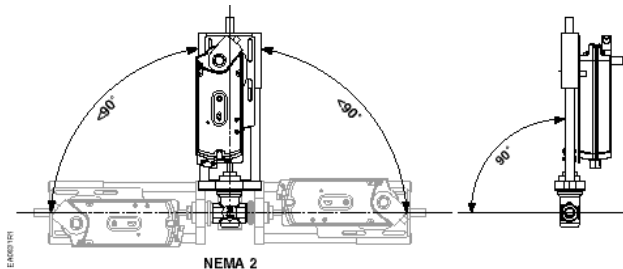

Figure 11. Acceptable NEMA 2 Mounting Positions. Wiring.

Wiring

All wiring must conform to NEC, and local codes and regulations.

Use earth ground isolating step-down Class 2 transformers. Do not use auto transformers.

Determine the supply transformer rating by summing the total VA of all actuators used. The maximum rating for a Class 2 step-down transformer is 100 VA.

Table 1 shows the recommended maximum actuators per Class 2 circuit and includes a safety factor of 80% of the transformer VA. Operating additional actuators requires additional transformers or separate 100 VA power trunks.

Table 1. Recommended Maximum Power Consumption (VA) for a Class 2 Step-Down Transformer.

Actuator	Power Consumption	Actuator per Class 2 Supply Circuit
GCA16...	9 VA	9
GCA12...	8 VA	10

References

Document Title	Document Number
Flowrite VF 599 Series Rack & Pinion Valves, Technical Instructions	155-541P25
TB249 Flowrite 599 Series Valve and Actuator Assembly Selection, Technical Bulletin	155-304P25

Wiring Diagrams

599-03609 Assembly (with GCA161.1U) for 24 Vac Modulating Control

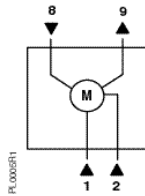

Table 2.
599-03609 Assembly (with GCA161.1U) for
24 Vac Modulating Control.

Standard Symbol	Function	Terminal Connection	Standard Color
1	Supply (SP)	G	Red
2	Neutral (SN)	G0	Black
8	0 to 10V input signal	Y	Gray
9	Output for 0 to 10 Vdc position feedback indication	U	Pink

599-03611 Assembly (with GCA121.1U) for 24 Vac Two-position Control

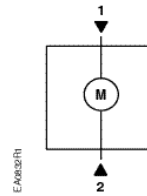

Table 3.
599-03611 Assembly (with GCA121.1U) for
24 Vac Two-position Control.

Standard Symbol	Function	Terminal Connection	Standard Color
1	Supply (SP)	G	Red
2	Neutral (SN)	G0	Black

Dimensions

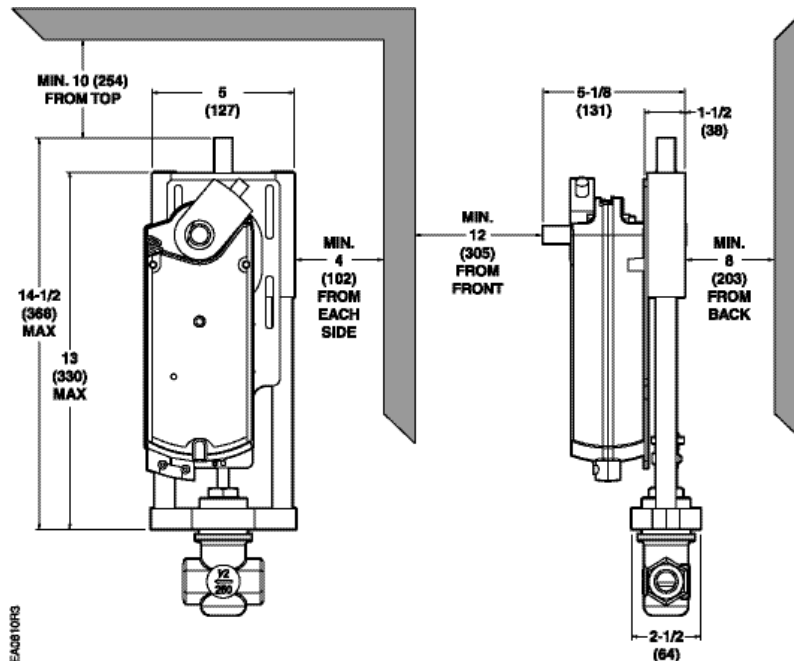

Figure 10. Dimensions of the Flowrite VF 599 Series Rack & Pinion Valve in Inches (Millimeters).

Information in this publication is based on current specifications. The company reserves the right to make changes in specifications and models as design improvements are introduced. OpenAir and Flowrite are registered trademarks of Siemens Industry, Inc. Other products or company names mentioned herein may be the trademarks of their respective owners. © 2007 Siemens Industry, Inc.