

Outdoor Mounting Installations K Series Devices

K Series products are designed to be NEMA 4X watertight and operate in a wide temperature range and can be used either indoors or outdoors. Do not attempt to use a box other than the one supplied with the product or recommended for the product, as doing so may compromise the NEMA 4X rating.

It is strongly recommended that the device be installed at the same time as the watertight back box to avoid water accumulation and potential damage.

If you have to replace a device, it is strongly recommended that you replace the outdoor back box as well.

K series products come with a plastic NEMA 4X outdoor rated back box, as well as removable side flanges for mounting, weatherproof threaded plugs and o-rings. The -R series devices do not come with our outdoor rated back box. The -R series products are intended for use with our WTP watertight NEMA 3R surface mount plates or with use of our NEMA 4X SA-WBB or MWBB series of metal outdoor watertight back boxes.

NOTE: Shorting Spring feature only available on K series Speaker and Speaker Strobes.

We offer K series for our wall and ceiling mount horns, strobes and horn/strobes, See Figure 1. As well as for our wall and ceiling mount Speaker and Speaker Strobes, See Figure 2.

K SERIES MOUNTING

The following instruction procedures to use when installing the K series devices. All wiring and installations must be in compliance with the National Electric Code (NEC) and all applicable local electrical and building codes.

1. The weatherproof back boxes come equipped with side flanges for mounting. The plastic versions come with removable side flanges. We recommend securing the back box directly to the wall or ceiling using these flanges. If this approach is not possible or is undesirable for aesthetic reasons, installers can use the small screw plugs on the back of the supplied weatherproof back box to mount directly to the wall or ceiling, or to a weatherproof electrical back box. For the wall mount products, an up arrow is indicated on the back box for orientation purposes. If the small screw knockouts are removed, they must be sealed with an outdoor or marine rated silicone. For horn, strobes and horn/strobes you can use the center holes for a single gang box and for a double gang box, you can use the four outer holes, See Figure 3. For speakers and speaker/strobes they can only be mounted to a 4x4 weatherproof electrical box. It is recommended that you use a screwdriver to remove the screw knockouts as shown in Figure 4.

2. The back box also includes threaded holes on the top and bottom of the back box for 3/4 inch NPT conduit adapters. In addition, conduit knockouts in the back of the box are provided for 3/4 inch NPT conduit entry. When using the rear conduit entry holes, the unused holes on the top and the bottom of the outdoor back box must be properly sealed. Threaded Plugs and O-rings are provided with the product for this purpose. It is recommended to put Teflon tape on the threads of the conduit plugs to ensure a proper seal. Watertight fittings should be used for all wiring connections, including the conduit knockouts and screw knockouts on the back of the box. See *Liquid-Tight Connectors and How to Use Them* for additional recommendations.

NOTE: Assuming the screw knockouts or the rear entry conduit knockouts are properly sealed, no additional sealing to the mounting surface is needed.

3. Water may compromise the back box due to condensation or direct exposure to rain or snow, it is the responsibility of the installer to make sure that all openings and connections are properly sealed. Even outdoor installations that are protected from direct exposure to rain are still subject to condensation or leakage through hidden areas, such as a soffit.
4. To attach the device mounting plate to the weatherproof back box, use the four supplied non-painted screws.

5. Follow the wiring instructions described in the indoor installation manual.

NOTE: In areas where humidity is a concern, we recommend blocking the conduit with minimally expanding foam designed for windows and doors.

6. To mount the device to the mounting plate, hook the tabs on the product housing into the grooves on the mounting plate. Then, swing the product into position to engage the pins on the device with the terminals on the mounting plate. Verify that the tabs on the back of the device are fully engaged with the mounting plate.

7. Finally, secure the device the mounting plate; for horn, strobes and horn/strobes you only require the single screw on the front of the housing. To secure the speaker and speaker strobe you must use all #8-32 x 3/8 inch flat head screws supplied.

NOTE: We recommend you use a hand-held screwdriver for the installation of the mounting plate. If you must use an electric screwdriver use it at its lowest torque setting.

FIGURE 1. WALL AND CEILING MOUNT HORN/STROBE WITH WEATHERPROOF BACKBOX:

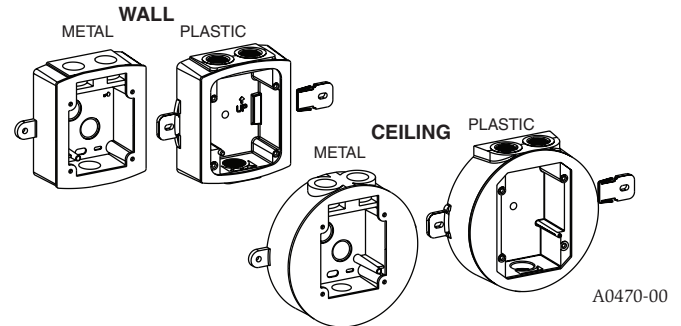

FIGURE 2. WALL AND CEILING SPEAKER/STROBE WEATHERPROOF BACKBOX:

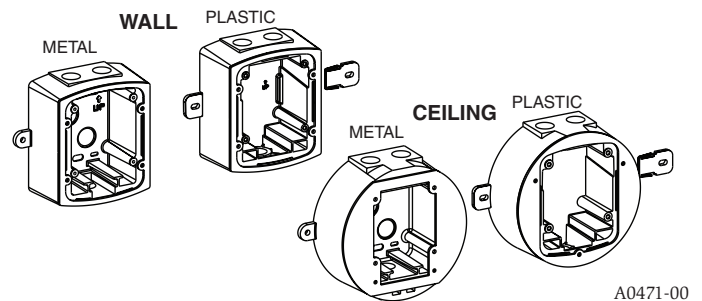

FIGURE 3. MOUNTING HOLE PATTERN:

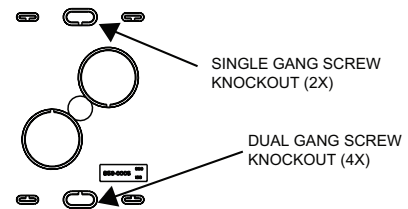
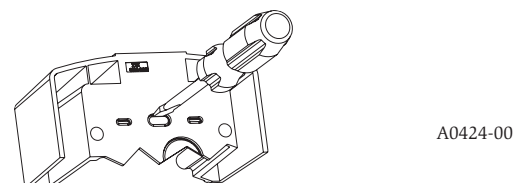

FIGURE 4. SCREW KNOCKOUT REMOVAL WITH SCREWDRIVER:



HOW TO INSTALL CONDUIT PLUGS

In order to maintain watertight performance, any unused conduit openings in SpectrAlert Advance weatherproof back boxes must be sealed using conduit plugs provided with the product. First slide the O-ring onto the conduit plug that is shipped with the unit. Install the conduit plug and O-ring in any unused threaded opening on the top and bottom of the back box using Teflon tape or silicone sealant on the plug's threads. Tighten the plug so it compresses the O-ring slightly without pushing it out of place. Do not overtighten. Repeat for any unused threaded openings in the back box.

LIQUID-TIGHT CONNECTORS AND HOW TO USE THEM

This section provides an overview of the different types of liquid-tight connections available. It also shows how to use the connectors to provide a watertight seal when connecting conduit to the outdoor device weatherproof back boxes—either through the rear knockout holes or through the threaded openings on the top and bottom of the back box.

TYPES OF LIQUID-TIGHT CONDUIT CONNECTORS

The conduit openings used to bring wire into any SpectrAlert Advance product should always be protected with a watertight conduit connector. There are several connector options available, including:

- Flexible liquid-tight conduit connector available in metal or plastic
- Rigid PVC conduit connector
- Cord grip connector
- Rigid conduit hub

While the proper SpectrAlert Advance weatherproof back box or mounting plate must be used with the correct product in order for the installation to remain watertight, each of the connectors above can be used in the threaded conduit openings or the rear knockouts as appropriate for the installation.

For example, when a System Sensor outdoor notification product is installed properly in conjunction with the appropriate plastic or metal outdoor back box, it will provide a NEMA4X rating. However, when a rear knockout is removed from the back box, the product no longer maintains this rating unless a NEMA4X-rated liquid-tight conduit connector is used.

The use of silicone sealant in the rear knockouts or threaded conduit openings is NOT recommended in lieu of using a liquid-tight connector or the provided conduit plugs. This approach will result in an unapproved installation that may not have the required watertight properties.

In applications where local codes do not require product wiring to be installed in conduit, it is recommended that a watertight cord grip connector or a watertight connector with a small length of conduit be used when using the rear knockouts to maintain a watertight seal.

HOW TO INSTALL LIQUID-TIGHT CONDUIT CONNECTORS IN REAR KNOCKOUTS

To install a liquid-tight conduit connector, first remove a rear knockout from the metal weatherproof back box by placing the flat blade of flat blade screwdriver along the edge of the slot and striking the screwdriver as you slowly work blade around the slot.

Insert the liquid-tight conduit connector into the knockout opening. Make sure that the connector's gasket is in between the connector and the back box. If a gasket is not provided with the connector, follow the manufacturer's instructions on how to use the connector in a knockout (an O-ring may need

to be purchased separately). Attach the conduit connector to the conduit per the manufacturer's instructions. Next, tighten the conduit connector nut on the inside of the back box and then secure the weatherproof back box to the mounting surface.

Remember to plug any unused conduit openings with the conduit plugs provided (see How to install conduit plugs).

HOW TO INSTALL LIQUID-TIGHT CONDUIT CONNECTORS IN THREADED OPENINGS

To install a liquid-tight conduit connector, first secure the weatherproof back box to the mounting surface. Thread the liquid-tight conduit connector into a threaded opening following the connector manufacturer's instructions for liquid-tight applications (this may require the use of Teflon tape or another thread sealant). Finally, connect the conduit to the connector per the manufacturer's instructions. See Figures 5 and 6.

FIGURE 5: LIQUID-TIGHT CONNECTORS

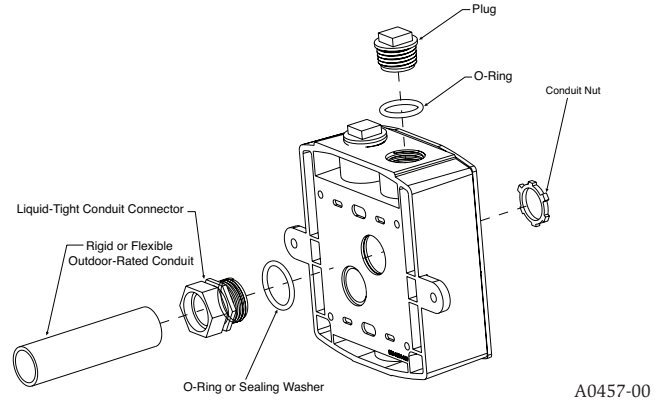
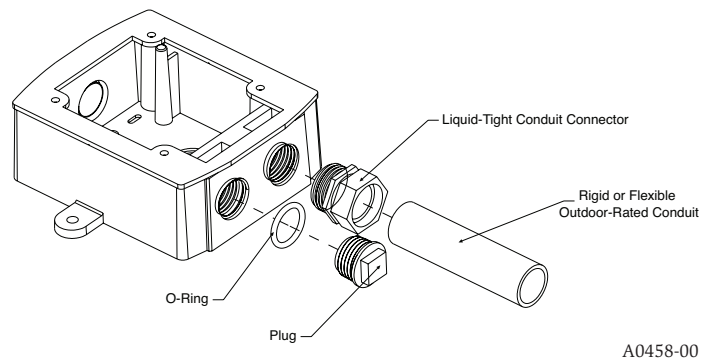

FIGURE 6: INSTALL IN TOP THREADED OPENINGS



Remember to plug any unused conduit openings with the conduit plugs provided (see How to Install Conduit Plugs).

THREE-YEAR LIMITED WARRANTY

System Sensor warrants its enclosed product to be free from defects in materials and workmanship under normal use and service for a period of three years from date of manufacture. System Sensor makes no other express warranty for this product. No agent, representative, dealer, or employee of the Company has the authority to increase or alter the obligations or limitations of this Warranty. The Company's obligation of this Warranty shall be limited to the replacement of any part of the product which is found to be defective in materials or workmanship under normal use and service during the three year period commencing with the date of manufacture. After phoning System Sensor's toll free number 800-SENSOR2 (736-7672) for a Return Authorization number, send defective units postage prepaid to: System Sensor, Returns Department, RA # _____, 3825

Ohio Avenue, St. Charles, IL 60174. Please include a note describing the malfunction and suspected cause of failure. The Company shall not be obligated to replace units which are found to be defective because of damage, unreasonable use, modifications, or alterations occurring after the date of manufacture. In no case shall the Company be liable for any consequential or incidental damages for breach of this or any other Warranty, expressed or implied whatsoever, even if the loss or damage is caused by the Company's negligence or fault. Some states do not allow the exclusion or limitation of incidental or consequential damages, so the above limitation or exclusion may not apply to you. This Warranty gives you specific legal rights, and you may also have other rights which vary from state to state.

FCC STATEMENT

SpectrAlert Strobes and Horn/Strobes have been tested and found to comply with the limits for a Class B digital device, pursuant to part 15 of the FCC Rules. These limits are designed to provide reasonable protection against harmful interference when the equipment is operated in a commercial environment. This equipment generates, uses, and

can radiate radio frequency energy and, if not installed and used in accordance with the instruction manual, may cause harmful interference to radio communications. Operation of this equipment in a residential area is likely to cause harmful interference in which case the user will be required to correct the interference at his own expense.