

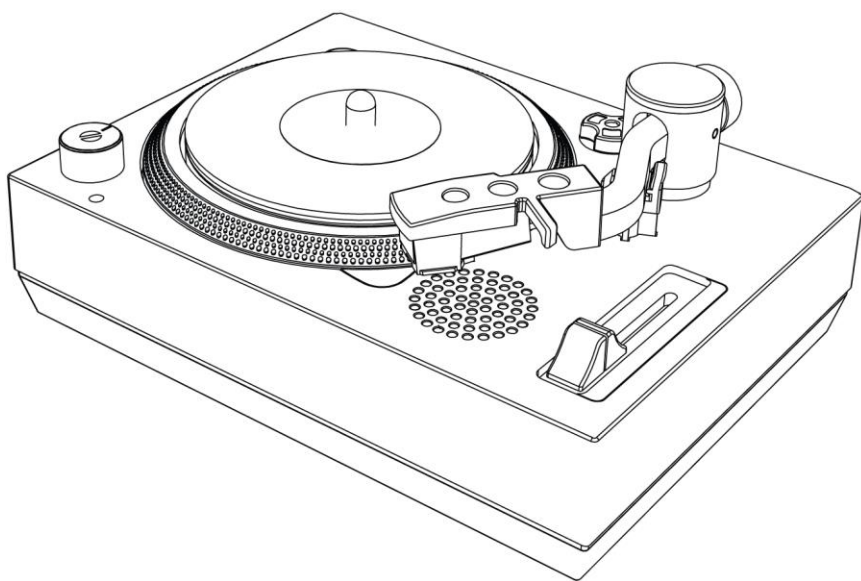

CR6037A
RSD3 Mini Turntable
Instruction Manual



Questions, problems, missing parts?
Before returning to the store, call Customer Service
8 a.m. – 6 p.m., EST, Monday – Friday
1-888-CROSLEY
www.crosleyradio.com

Safety Instructions

Read and understand this entire manual before using this product. Keep these instructions for future reference.

1. Do not use this product near water.
2. This product should be operated only by the type of power source indicated on the marking label or in this instruction manual.
3. Do not defeat the safety purpose of the polarized plug. A polarized plug has two blades with one blade wider than the other. This plug will fit into the power outlet only one way. If you are unable to insert the plug fully into the outlet try reversing the plug. If the plug should still fail to fit, contact your electrician.
4. Protect the power cord from being walked on or pinched particularly at plugs, convenience receptacles, and the point where they exit from the product.
5. Do not overload wall outlets, extension cords, or integral convenience receptacles as this can result in a risk of fire or electric shock.
6. Never push objects of any kind into this product through openings as they may touch dangerous voltage points or short-out parts that could result in a fire or electric shock. Never spill liquid of any kind on the product.
7. Do not attempt to service this product yourself as opening or removing covers may expose you to dangerous voltage or other hazards. Refer all servicing to qualified service personnel.
8. Changes or modifications to this unit not expressly approved by the party responsible for compliance could void the user's authority to operate the equipment.
9. Do not use attachments not recommended by the product manufacturer as they may cause hazards.
10. A product and cart combination should be moved with care. Quick stops, excessive force, and uneven surfaces may cause the product and cart combination to overturn.
11. Slots and openings in the cabinet are provided for ventilation and to ensure reliable operation of the product and to protect it from overheating. Do not block or cover these openings.
12. Unplug the product during lightning storms or when unused for long periods of time.

Items in this package

Before throwing away any packaging materials, please check thoroughly and make sure you find the following items that come along with this package:

- Turntable
- Turntable Lid
- Record adapter x 2
- Power adaptor
- Aux In Cable
- 3.5 MM to RCA

Please contact Crosley customer service if there is any accessory missing from the package. **Retain the original packaging materials for exchange or return purposes.**

Specifications

Power	Micro USB Cable / 4 x AAA Batteries (Not Included)
Power consumption	2W
Speaker	1, 4Ω, 2W
Turntable speed	33 ¹ / ₃ RPM
Replacement needle	Crosley NP5

Note:

- *Design and specifications are subject to change without notice.*
- **To help save power consumption, some models will comply with ERP energy saving standard. When there is no audio input for 20 minutes, the power will automatically cut-off. To turn power back on and resume playing, you will need to turn off the power and turn it on again.**

Product Description

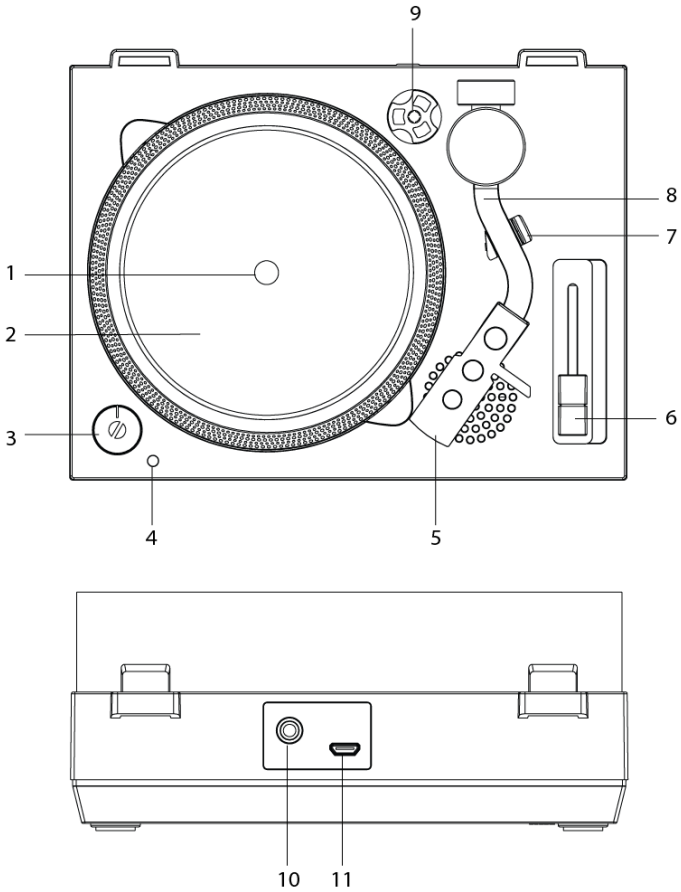

- 1. Turntable Spindle
- 2. Turntable Platter
- 3. On/Off-Volume Knob
- 4. Power Indicator
- 5. Headshell
- 6. Pitch Control

- 7. Tonearm Rest
- 8. Tonearm
- 9. Record Adapter
- 10. Headphone/Aux Out Jack
- 11. Power Jack

Turntable Operation

1. Place the record on the turntable. Use the Record Adapter if necessary.
2. Rotate the On/Off Volume Knob to turn on the power.
3. Remove the stylus protector from the stylus assembly.
Note: To avoid stylus damage, make certain the included stylus guard is in place whenever the turntable is being moved or cleaned.
4. Lift tonearm from the tonearm rest.
Note: When the turntable is not in use, remember to secure it to the tonearm rest.
5. Move the tonearm over the record to desired starting point, and gently lower tonearm onto record.
6. When the record is finished playing, lift tonearm, and return it to the Tonearm Rest.
7. Push the tonearm into the tonearm rest.

Aux Output Connection

You can connect speakers to this unit and play your music through your speakers. To do this, connect the 3.5mm auxiliary cable between your active speakers and the **Headphone/Aux Out Jack** of this unit and start playing the music.

Pitch Control

The turntable speed can be increased or decreased by approximately 10% by pushing the Pitch Control up or down. To increase the speed, push the Pitch Control up. To decrease the speed, push the Pitch Control down.

Needle Replacement

Removing Needle

1. Gently pull down the front edge of the needle.
2. Pull needle forward.
3. Pull out and remove.

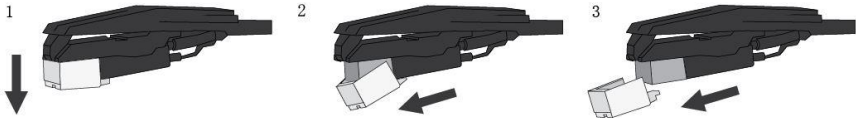

Installing Needle

1. Position the needle with its tip facing down.
2. Line up the back of the needle with the cartridge.
3. Insert the needle with its front end at a downward angle and gently lift the front of the needle upward until it snaps into place.

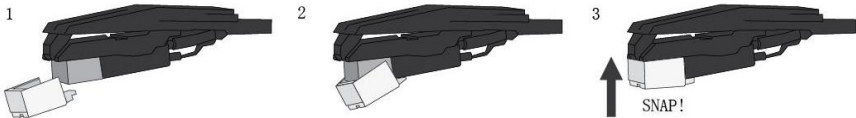

FCC Statements

This equipment has been tested and found to comply with the limits for a Class B digital device, pursuant to Part 15 of the FCC Rules. These limits are designed to provide reasonable protection against harmful interference in a residential installation. This equipment generates, uses, and can radiate radio frequency energy and, if not installed and used in accordance with the instructions, may cause harmful interference to radio communications. However, there is no guarantee that interference will not occur in a particular installation. If this equipment does cause harmful interference to radio or television reception, which can be determined by turning the equipment off and on, the user is encouraged to try to correct the interference by one or more of the following measures:

- Reorient or relocate the receiving antenna.
- Increase the separation between the equipment and receiver.
- Connect the equipment into a circuit different from that to which the receiver is connected.
- Consult the dealer or an experienced radio TV technician for help.