

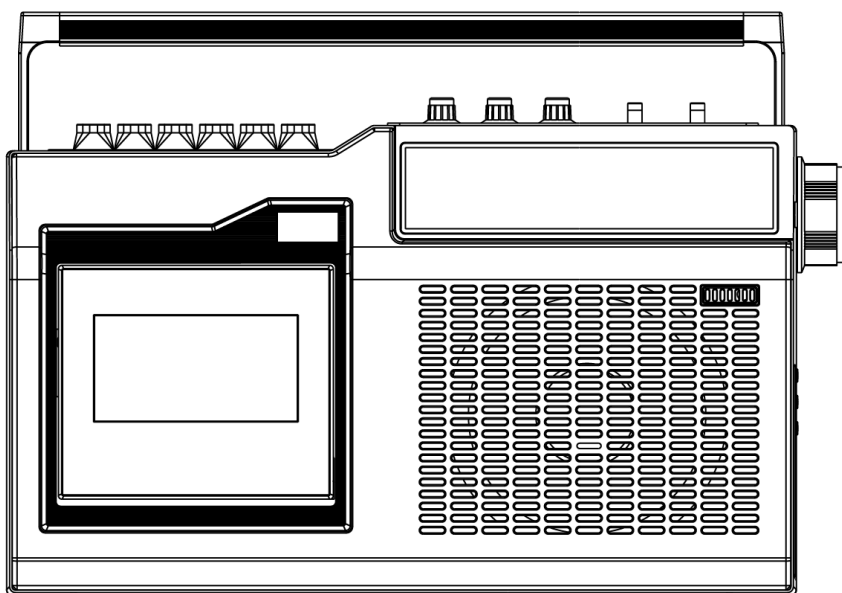

**CT200A**  
**Cassette Player**  
**Instruction Manual**

---



Questions, problems, missing parts?  
Before returning to the store, call Customer Service  
8 a.m. – 6 p.m., EST, Monday – Friday  
1-888-CROSLEY  
[www.crosleyradio.com](http://www.crosleyradio.com)

## **Safety Instructions**

---

Read and understand this entire manual before using this product. Keep these instructions for future reference.

1. Do not use this product near water.
2. This product should be operated only by the type of power source indicated on the marking label or in this instruction manual.
3. Do not defeat the safety purpose of the polarized plug. A polarized plug has two blades with one blade wider than the other. This plug will fit into the power outlet only one way. If you are unable to insert the plug fully into the outlet try reversing the plug. If the plug should still fail to fit, contact your electrician.
4. Protect the power cord from being walked on or pinched particularly at plugs, convenience receptacles, and the point where they exit from the product.
5. Do not overload wall outlets, extension cords, or integral convenience receptacles as this can result in a risk of fire or electric shock.
6. Never push objects of any kind into this product through openings as they may touch dangerous voltage points or short-out parts that could result in a fire or electric shock. Never spill liquid of any kind on the product.
7. Do not attempt to service this product yourself as opening or removing covers may expose you to dangerous voltage or other hazards. Refer all servicing to qualified service personnel.
8. Changes or modifications to this unit not expressly approved by the party responsible for compliance could void the user's authority to operate the equipment.
9. Do not use attachments not recommended by the product manufacturer as they may cause hazards.
10. A product and cart combination should be moved with care. Quick stops, excessive force, and uneven surfaces may cause the product and cart combination to overturn.
11. Slots and openings in the cabinet are provided for ventilation and to ensure reliable operation of the product and to protect it from overheating. Do not block or cover these openings.
12. Unplug the product during lightning storm or when unused for long periods of time.

## Items in this package

---

Before throwing away any packaging materials, please check thoroughly and make sure you find the following items that come along with this package:

- Cassette Player
- Power plug

Please contact Crosley customer service if there is any accessory missing from the package. **Retain the original packaging materials for exchange or return purposes.**

## Specifications

---

Power	AC 120 V / 60 Hz D Batteries X 6 (Not Included)
Power consumption	5W
Speaker	6 $\Omega$

Note:

- *Design and specifications are subject to change without notice.*
- **To help save power consumption, some models will comply with ERP energy saving standard. When there is no audio input for 20 minutes, their powers will automatically cut-off. To turn power back on and resume playing, you will need to turn off the power and turn it on again.**

## Product Description

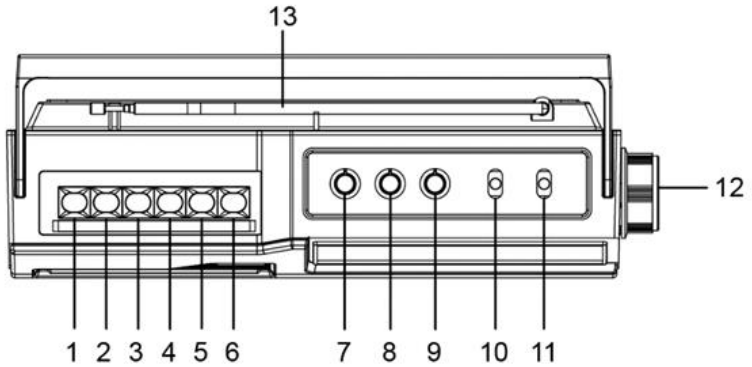

- 1. Pause Button
- 2. Stop/Eject Button
- 3. Fast Forward Button
- 4. Rewind Button
- 5. Play Button
- 6. Record Button
- 7. Volume Knob
- 8. Bass Knob
- 9. Treble Knob
- 10. Function Switch
- 11. AM/FM Switch
- 12. Tuning Knob
- 13. External Antenna
- 14. Cassette Tray
- 15. Microphone
- 16. Dial Scale
- 17. Power Plug
- 18. Headphone Jack

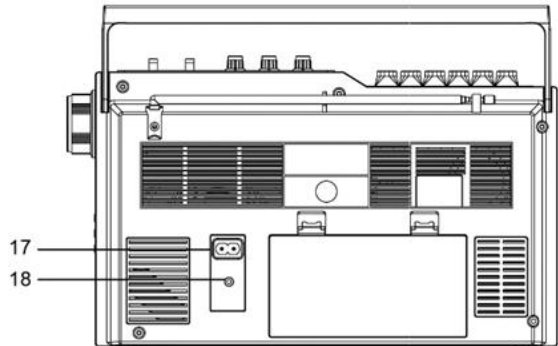
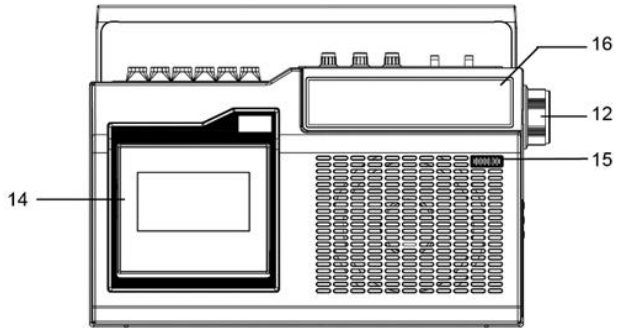

## Radio Operation

---

1. Set the Function Switch to RADIO position.
2. Set the AM/FM Switch to FM or AM position.
3. Rotate the Tuning Knob for desired radio station.

*Note:*

- *When operating FM radio, pull up the TELESCOPIC ANTENNA, and adjust position to get better reception.*

## Cassette Operation

---

1. Set the Function Switch to TAPE position.
2. Insert the prerecorded cassette into the cassette tray, and press the Play button.
3. To fast forward, press the Fast Forward button in. To stop fast forwarding and return to the playback mode, press the Play button.
4. To rewind, press the Rewind button in. To stop rewinding and return to the playback mode, press the Play button.
5. To stop the playback, press the Stop/Eject button once. To eject the cassette, press the Stop/Eject button again.

*Note: Remove the cassette from the cassette holder when it is not in use.*

## Sleep Function

---

1. Set the Function Switch to Sleep position.
2. Insert a cassette tape, and press the play button.
3. Select your desired radio station and it will play.
4. At the end of the tape; the Play button will be ejected and go into Sleep Mode.

*Note: This function will only play radio only.*

## Recording

---

1. Set the Function Switch to TAPE position.
2. Insert a cassette tape, and press the RECORD button to record the sounds through the microphone.

*Note: To prevent accidental recording, break off the cassette tab from side A or B.*

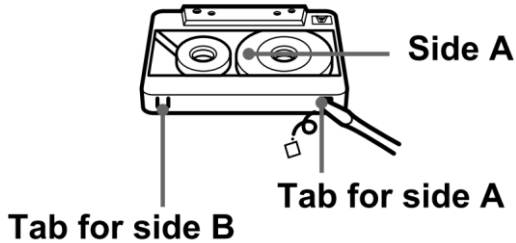

3. To pause recoding, press the Pause button.
4. To stop recording, press the Stop/Eject button.

## **FCC Statements**

---

This equipment has been tested and found to comply with the limits for a Class B digital device, pursuant to Part 15 of the FCC Rules. These limits are designed to provide reasonable protection against harmful interference in a residential installation. This equipment generates, uses, and can radiate radio frequency energy and, if not installed and used in accordance with the instructions, may cause harmful interference to radio communications. However, there is no guarantee that interference will not occur in a particular installation. If this equipment does cause harmful interference to radio or television reception, which can be determined by turning the equipment off and on, the user is encouraged to try to correct the interference by one or more of the following measures:

- Reorient or relocate the receiving antenna.
- Increase the separation between the equipment and receiver.
- Connect the equipment into a circuit different from that to which the receiver is connected.
- Consult the dealer or an experienced radio TV technician for help.