

# PAIGNTON

PROGRAMME of EVENTS 2018



Paignton Sailing Club

# **Exe Sails & Covers**



## **Your Local Sailmaker**

**Exe Sails & Covers Ltd  
1 Topsham Units  
Dart Business Park  
Topsham  
Exeter, Devon**

**01392 874449**

**info@exesails.com**

**www.exesails.com**

**Racing Sails  
Cruising Sails  
Dinghy & One Design Sails  
Sail & Canvas Repairs  
Sprayhoods & Enclosures  
Sail Covers & Dodgers  
General Canvas Work  
Powerboat & Rib Covers  
Cushions & Upholstery**

---

**Sam Woolner - Pete Handscomb  
Mark 'Spoons' Jenkins - Ned Taylor**

---

**Industrial sewing repairs and alterations**

## GENERAL COMMITTEE

<b>Commodore</b>	Graham Slater	commodore@paigntonailingclub.co.uk
<b>Sailing Secretary</b>	Nick Ripley	sailing@paigntonailingclub.co.uk
<b>Social Secretary</b>	Calvin Maulder	moulder@gmx.com
<b>Treasurer</b>	Dale Giles	hello@paigntonailingclub.co.uk
<b>Secretary</b>	Vanessa Ripley	secretary@paigntonailingclub.co.uk
<b>Championship Coordinator</b>	Dale Giles	events@paigntonailingclub.co.uk
<b>Publicity and Marketing</b>	Arthur Phillips	publicity@paigntonailingclub.co.uk
<b>Membership Secretary</b>	Julie Cronk	membership@paigntonailingclub.co.uk
<b>Training Coordinator</b>	Jackie Gater	training@paigntonailingclub.co.uk
<b>House Manager</b>	Mike Holmes	mikeh99@blueyonder.co.uk
<b>Junior Club Representative</b>	Paul Procter	juniors@paigntonailingclub.co.uk
<b>Grant Application Coordinator</b>	Alan Robinson	alanandruthrobinson@gmail.com
<b>Committee member</b>	Richard Stones	windsurfing@paigntonailingclub.co.uk
<b>Committee member</b>	Elaine Slater	elaine@hypro.co.uk

## NON-COMMITTEE POSTS

<b>Bosun</b>	Fred Whitehead	bosun@paigntonailingclub.co.uk
<b>Results Coordinator</b>	Mike Holmes	mikeh99@blueyonder.co.uk
<b>Duty Rota</b>	Sam Garwood	duties@paigntonailingclub.co.uk

**Paignton Sailing Club**  
South Quay  
Paignton Harbour  
TQ4 6DT  
tel: 01803 525817  
email: [secretary@paigntonailingclub.co.uk](mailto:secretary@paigntonailingclub.co.uk)  
[www.paigntonailingclub.co.uk](http://www.paigntonailingclub.co.uk)  
[www.facebook.com/paigntonailingclub](http://www.facebook.com/paigntonailingclub)

# Commodore's Introduction

A warm welcome to Paignton Sailing Club to new members and old friends alike. We hope that the 2018 sailing season will be our best yet.

Seasoned members will know this is my third stint as Commodore and it is an honour.

This year, I would like to put a little more emphasis on encouraging our adult racing membership and fostering some apres-sail in the clubroom! To this end, we are experimenting with running some cup races on Saturday afternoons and following these with an evening meal provided by Calvin in the bar. I will also be making sure that the bar is open after Sunday morning racing. We already know how successful the Wednesday evening racing has been and how people enjoy having a meal in the clubroom afterwards. I hope everyone will support us by coming and having a drink and a chat after the racing – it is all part of the fun. Please encourage your partners to join us for food and drink. The bar itself is being improved this year and we hope to have some popular drinks on tap at very reasonable prices. Remember that you can use your membership card to pay for food, drinks and boat hire. This means you can avoid bringing cash to the club once you have topped up your card.

The normal club racing resumes on 1st April (Easter Sunday) and the first Wednesday evening is on 4th April. Please see the online calendar for up to the minute racing schedules [www.paigntonsailingclub.co.uk/home/whats-on/](http://www.paigntonsailingclub.co.uk/home/whats-on/).

Don't miss the pre-season social on Friday 9th March at 7:30 pm where I look forward to welcoming everyone.

As usual, we will be busy on the training front on Friday evenings and courses can be found on the website. Once again, volunteers will be needed to help and we hope that as many parents as possible muck in on the junior courses. It's a great way to meet people and have fun. Look out for the special training weekends for the various junior fleets. We are even hosting the RYA South and South West Windsurfer Squad training in March!

Don't forget that club boats can be hired at the bar for participation in club racing. This year we are giving a special concession to new members in 2018 who are signed up for a beginner's course. Hopefully, last year's beginner's will be looking to purchase their own boats this year and there's plenty of advice on what to buy on a Wednesday evening in the bar! Anyone wanting a space in the club compound should come and see me or drop me an email.

Wishing everyone a very successful season!

GRAHAM SLATER  
Commodore

<b>January</b>	<b>Event</b>	<b>Time</b>
Monday 1st	Christmas Cracker	11:00
<b>Saturday 6th</b>	<b>29er Training</b>	
<b>Sunday 7th</b>	<b>Snowman / 29er Training</b>	11:00
Sunday 14th	Snowman	11:00
<b>Saturday 20th</b>	<b>Topper Training</b>	
<b>Sunday 21st</b>	<b>Snowman / Topper Training</b>	11:00
<b>Sunday 28th</b>	<b>South West Winter Series - Roadford Rocket</b>	

<b>February</b>	<b>Event</b>	<b>Time</b>
Sunday 4th	Snowman	11:00
<b>Saturday 10th</b>	<b>Topper Training/South West Winter Series-Portishead YSC</b>	
<b>Sunday 11th</b>	<b>Snowman / Topper Training</b>	11:00
<b>Saturday 17th</b>	<b>29er Training</b>	
<b>Sunday 18th</b>	<b>Snowman / 29er Training</b>	11:00
<b>Sunday 25th</b>	<b>South West Winter Series - Starcross Steamer</b>	

<b>March</b>	<b>Event</b>	<b>Time</b>
<b>Saturday 3rd</b>	<b>RYA Dinghy Show / 29er Training</b>	
<b>Sunday 4th</b>	<b>Snowman / RYA Dinghy Show / 29er Training</b>	11:00
<b>Friday 9th</b>	<b>Pre-season Social</b>	<b>19:30</b>
<b>Saturday 10th</b>	<b>RYA Topper UK Junior squad / SWWS - Sutton Bingham</b>	
<b>Sunday 11th</b>	<b>Snowman / RYA Topper UK Junior squad</b>	11:00
<b>Saturday 17th</b>	<b>RYA S/SW Windsurfer Squad Training</b>	
<b>Sunday 18th</b>	<b>RYA S/SW Windsurfer Squad Training/SWWS - Wimbleball</b>	
<b>Saturday 24th</b>	<b>ITCA Topper 4.2 squad / SWYSA - Feva Training</b>	
<b>Sunday 25th</b>	<b>ITCA Topper 4.2 squad / SWYSA - Feva Training</b>	
Wednesday 28th	Spring Wednesday	18:30
<b>Saturday 31st</b>	<b>Sail-Away Day and BBQ</b>	<b>9:30</b>



Sponsored by



www.sailingchandlery.com

Photo: Steve Cayley



Photo: Steve Cayley

PAIGNTON OPEN FOR  
SINGLE HANDED DINGHIES

**POSH**

Photo: Nathan Gribbin



Sat 26th May  
Sun 27th May

Sat 12th May  
Sun 13th May



Photo: Steve Cayley

PAIGNTON OPEN FOR  
DOUBLE HANDED DINGHIES

**PODD**

**Paignton Sailing Club**

Paignton Harbour, PaigntonTQ46DT  
sailing@paigntonsailingclub.co.uk  
paigntonsailingclub.co.uk  
facebook.com/paigntonsailingclub

**For BOTH Events:**

2 days of racing

6 races in total

Pre-entry online

Discount for early entry

Saturday Evening Reception

# POSH & PODD

Now in their 7th year our two Flagship Events have been growing in popularity year on year and have now become part of the established race circuit for some of the fleets.

## POSH 2017

For the 2017 Paignton Open for Single Handed dinghies we had exactly 60 boats. The classes included: RS100s, D-Ones, Phantoms, RS600s, Blazes, RS Aero 7s and 9s, D-Zeros, Lasers, Laser Radials and 4.7s, Europes and an OK.

Due to the number of boats we ran 4 start sequences, meaning we had about 15 to 20 boats in each start, this really helped to spread out the competitors and made finishing easier as we used a finish boat as well as start boat. Having this type of system means we can keep sailors sailing rather than waiting for other fleets to finish before starting the 4 start sequences again. We had 2 days of good weather with just the right amount of wind, in that time we managed to get in 3 races each day making a 6 race series. Another successful event!

## PODD 2017

The Paignton Open for Double handed Dinghies traditionally does not attract the numbers that POSH does, nevertheless we had a great selection of classes with the Fireballs, as usual, in abundance. 20 boats turned up for a weekend of excellent weather for racing. The classes that supported us this year were: Fireballs, Tasars, Laser 4000s, Merlin Rockets, RS200s, Scorpions, Albacores, RS400s, 2000s and a Comet Trio. Not surprisingly the Fireballs dominated the results sheet with celebrity helms and crews like Thomas Gillard and Geoff Edwards on the startline!

## POSH & PODD 2018

This year we are again hosting these two iconic events and hope that more of our home grown helms will participate. If you haven't taken part in a big open event before this is a great opportunity to try one and enjoy the thrill and spectacle of competing on the water with so many boats of varying classes. Hope to see you there!



**Specialising in Aluminium  
& Stainless Steel  
fabrication & repair**

**Aluminium wheel repair  
Launching Trolleys for Boats  
almost 1/3 the weight of steel**

## **TIGMAN WELDING**

**Graham Slater  
Proprietor**

**Tel. & Fax: (01626) 330133**

**Mobile: 07947 171235**

**graham@tigman.co.uk**

**www.tigman.co.uk**

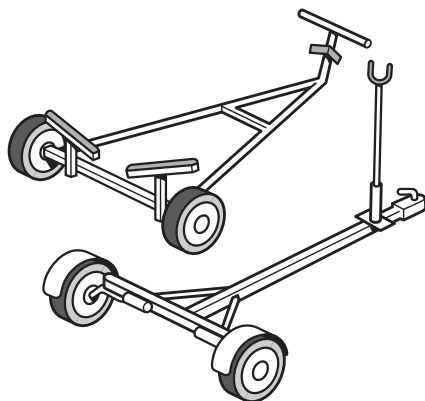

# **Taylor's<sup>T</sup>**

## **TOOL + FIXINGS CENTRE**

*The reliable partner for your industry*

**STAINLESS STEEL FASTENERS - WOODSCREWS - NAILS**

**ABRASIVES - SAWS - WALL PLUGS - DRILLS**

**MASONARY DRILLS - HAND TOOLS - ELEC POWER TOOLS & EQUIPMENT**

## **Distributors and Stockists of**

**metabo**

**DEWALT**

**BOSCH**  
Invented for life

**torbay@taylorsltd.co.uk**

**01803 324 095**

**Barton Hill, Road, Torquay**



April	Event	Time
Sunday 1st	Spring Sunday	10:30
<b>Monday 2nd</b>	<b>South West Winter Series - Torbay Tornado - RTYC</b>	
Wednesday 4th	Spring Wednesday	18:30
<b>Friday 6th</b>	<b>Big Friday Evening Sailing - All welcome!</b>	<b>18:00</b>
<b>Saturday 7th</b>	<b>Topper Training / PB2 Course / PSC at Home</b>	<b>19:30</b>
<b>Sunday 8th</b>	Spring Sunday / <b>Topper Training</b>	10:30
Wednesday 11th	Spring Wednesday	18:30
<b>Friday 13th</b>	<b>Big Friday Evening Sailing - All welcome!</b>	<b>18:00</b>
<b>Saturday 14th</b>	<b>SWYSA - Feva Training</b>	
<b>Sunday 15th</b>	Spring Sunday / <b>SWYSA - Feva Training</b>	10:30
Wednesday 18th	Spring Wednesday	18:30
<b>Friday 20th</b>	<b>Big Friday Evening Sailing - All welcome!</b>	<b>18:00</b>
<b>Saturday 21st</b>	<b>29er Training / RYA SW Topper Zone Squad</b>	
<b>Sunday 22nd</b>	Spring Sunday / <b>29er Training / RYA SW Toppers</b>	10:30
Wednesday 25th	Spring Wednesday	18:30
<b>Friday 27th</b>	<b>Big Friday Evening Sailing - All welcome!</b>	<b>18:00</b>
<b>Saturday 28th</b>	<b>SWYSA - Tera/Topper Training / Adult Beginners Course</b>	
<b>Sunday 29th</b>	Spring Sunday / <b>SWYSA - Tera/Topper Training</b>	10:30
<b>Sunday 29th</b>	<b>Adult Beginners Course</b>	

## House Manager's Report

I'm the resident house manager (assisted by John Worthington) at the club and also an avid Blaze sailor. The past couple of years has seen the clubroom and training room redecorated, new windows installed, and a new cooker and dishwasher in the galley. Last year the front of the club (harbour side) has been completely refurbished with all new signage above and either side of the men's changing room door, with photos on a large montage, including ones of club members. There are also the usual "behind the scenes" general maintenance jobs like changing lamps/lock maintenance/organising cleaners/putting up and taking down the Christmas tree and decorations. We are currently having a big bar revamp with new beer pumps being installed. There are always some smaller jobs on the to do list so if anyone wants to volunteer to help please don't be shy! Good sailing ....

**Mike Holmes** House Manager

# OUR AWARD WINNING BEERS



**BAYS**  
BREWERY



## BAYS GOLD

Alc 4.3% Vol

Our Head Brewer's favourite. An easy drinking, light golden ale with a unique blend of hops that create refreshing lemon citrus overtones.



## DEVON DUMPLING

Alc 5.1% Vol

A strong premium beer with a fresh hop character. This ale has a smooth taste with a balanced sweetness. Devonshire through and through!



## TOPSAIL

Alc 4.0% Vol

This exceptional ale is the brewery's flagship product. It is well balanced, deep amber in colour with a subtle sweetness throughout.

# DEVON'S OF BEER CHOICE



CALL US NOW TO PLACE YOUR ORDER: 01803 555004 [www.baysbrewery.co.uk](http://www.baysbrewery.co.uk)

FIND US AT:  [facebook.com/baysbrewery](https://facebook.com/baysbrewery)  [twitter.com/baysbrewery](https://twitter.com/baysbrewery)

May	Event	Time
Wednesday 2nd	Spring Wednesday	18:30
<b>Friday 4th</b>	<b>Big Friday Evening Sailing - All welcome!</b>	<b>18:00</b>
Sunday 6th	Spring Sunday	10:30
Wednesday 9th	Harena Pursuit Race	18:30
<b>Friday 11th</b>	<b>Big Friday Evening Sailing - All welcome!</b>	<b>18:00</b>
<b>Saturday 12th</b>	<b>Paignton Open for Single Handers (POSH)</b>	
<b>Saturday 12th</b>	<b>POSH Evening Reception at PSC</b>	
<b>Sunday 13th</b>	<b>Paignton Open for Single Handers (POSH)</b>	10:30
Wednesday 16th	Summer Wednesday	18:30
<b>Friday 18th</b>	<b>Big Friday Evening Sailing - All welcome!</b>	<b>18:00</b>
Sunday 20th	Spring Sunday	10:30
Wednesday 23rd	Harena Pursuit Race	18:30
<b>Friday 25th</b>	<b>Big Friday Evening Sailing - All welcome!</b>	<b>18:00</b>
Wednesday 23rd	Harena Pursuit Race	18:30
<b>Friday 25th</b>	<b>Big Friday Evening Sailing - All welcome!</b>	<b>18:00</b>
<b>Saturday 26th</b>	<b>Paignton Open for Double Handers (PODD)</b>	
<b>Saturday 26th</b>	<b>PODD Evening Reception at PSC</b>	
<b>Sunday 27th</b>	<b>Paignton Open for Double Handers (PODD)</b>	
Wednesday 30th	Summer Wednesday	18:30

## Windsurfing Report

We have started a new and fun part of the club dedicated to Windsurfing; it is open for juniors, youth and adults. Our aim is to encourage juniors and adults to take up windsurfing, to have fun and for those of us that enjoyed it a few years ago, to get back into it!

After a fun trial last Summer we want to really build on this and so, windsurfing will start again from the end of March 2018; it will be a part (but separate) of the 'Big Friday Night Sailing' programme.

Each Friday we will have two to three hours on the water and the format will provide tuition from beginner to advanced, and to also enjoy a few hours of fun on the water in a safe and structured learning environment.

We currently have three boards, 2 Fanatic Vipers and a Mistral NTrance and several rigs from 3.5m to 6m, but we also welcome anyone to bring your own gear. If you are also interested in helping with this, or taking part then please contact Richard at: windsurfing@paigntonsailingclub.co.uk

**Richard Stones** Windsurfing Representative

June	Event	Time
Friday 1st	<b>Big Friday Evening Sailing - OPEN EVENING!!</b>	<b>17:00</b>
Saturday 2nd	<b>Torbay Airshow</b>	
Sunday 3rd	<b>Torbay Airshow</b>	
Wednesday 6th	Harena Pursuit Race	18:30
Friday 8th	<b>Big Friday Evening Sailing - Junior Training Course</b>	<b>18:00</b>
Sunday 10th	Summer Sunday	10:30
Wednesday 13th	Summer Wednesday	18:30
Friday 15th	<b>Big Friday Evening Sailing - Junior Training Course</b>	<b>18:00</b>
Saturday 16th	<b>Adult Beginners Course / Babbacombe Regatta</b>	
Sunday 17th	Summer Sunday/Adult Beg. Course / B.combe Reg.	10:30
Wednesday 20th	Harena Pursuit Race	18:30
Friday 22nd	<b>Big Friday Evening Sailing - Junior Training Course</b>	<b>18:00</b>
Saturday 23rd	<b>Prince of Wales / Sailing Supper</b>	<b>15:00</b>
Wednesday 27th	Summer Wednesday	18:30
Friday 29th	<b>Big Friday Evening Sailing - Junior Training Course</b>	<b>18:00</b>
Saturday 30th	<b>Junior Fun Training Weekend</b>	

July	Event	Time
Sunday 1st	Summer Sunday / <b>Junior Fun Training Weekend</b>	10:30
Wednesday 4th	Summer Wednesday	18:30
Friday 6th	<b>Big Friday Evening Sailing - Junior Training Course</b>	<b>18:00</b>
Sunday 8th	Summer Sunday	10:30
Wednesday 11th	Summer Wednesday	18:30
Friday 13th	<b>Big Friday Evening Sailing - All welcome!</b>	<b>18:00</b>
Saturday 14th	<b>Brixham Yacht Club – Dinghy Regatta</b>	
Sunday 15th	<b>Brixham Yacht Club – Dinghy Regatta</b>	
Wednesday 18th	Late Summer Wednesday	18:30
Friday 20th	<b>Big Friday Evening Sailing - All welcome!</b>	<b>18:00</b>
Saturday 21st	<b>Adult Level 2 Sailing Course</b>	
Sunday 22nd	Summer Sunday / <b>Adult Level 2 Sailing Course</b>	10:30
Wednesday 25th	Late Summer Wednesday	18:30
Friday 27th	<b>Big Friday Evening Sailing - All welcome!</b>	<b>18:00</b>
Saturday 28th	<b>Paignton Harbour Festival &amp; PSC OPEN DAY!</b>	
Sunday 29th	Summer Sunday	10:30



<b>August</b>	<b>Event</b>	<b>Time</b>
Wednesday 1st	Late Summer Wednesday	18:30
<b>Thursday 2nd</b>	<b>B14 Nationals Begin</b>	
<b>Friday 3rd</b>	<b>Big Friday Evening Sailing - All welcome!</b>	<b>18:00</b>
<b>Sunday 5th</b>	<b>B14 Nationals End</b>	
Wednesday 8th	Late Summer Wednesday	18:30
<b>Friday 10th</b>	<b>Big Friday Evening Sailing - All welcome!</b>	<b>18:00</b>
<b>Saturday 11th</b>	<b>Round The Bay 3.00-5.00 / Sailing Supper 6.30-8.30</b>	
Wednesday 15th	Late Summer Wednesday	18:30
<b>Friday 17th</b>	<b>Big Friday Evening Sailing - All welcome!</b>	<b>18:00</b>
Sunday 19th	Late Summer Sunday	10:30
Wednesday 22nd	Late Summer Wednesday	18:30
<b>Friday 24th</b>	<b>Big Friday Evening Sailing - All welcome!</b>	<b>18:00</b>
Sunday 26th	Late Summer Sunday	10:30
Wednesday 29th	Twilight	18:30
<b>Friday 31st</b>	<b>Big Friday Evening Sailing - All welcome!</b>	<b>18:00</b>

<b>September</b>	<b>Event</b>	<b>Time</b>
<b>Saturday 1st</b>	<b>Topper Open Training - PSC</b>	
<b>Sunday 2nd</b>	<b>Topper Open Meeting - PSC</b>	
Wednesday 5th	Twilight	18:00
<b>Friday 7th</b>	<b>Big Friday Evening Sailing - All welcome!</b>	<b>18:00</b>
<b>Saturday 8th</b>	<b>Orestone Race 3pm-5pm / Sailing Supper</b>	<b>18.30</b>
Wednesday 12th	Twilight	18:00
<b>Friday 14th</b>	<b>Big Friday Evening Sailing - All welcome!</b>	<b>18:00</b>
<b>Saturday 15th</b>	<b>Adult Beginners Course</b>	
<b>Sunday 16th</b>	<b>Late Summer Sunday / Adult Beginners Course</b>	10:30
Wednesday 19th	Twilight	18:00
<b>Friday 21st</b>	<b>Big Friday Evening Sailing - All welcome!</b>	<b>18:00</b>
Sunday 23rd	Late Summer Sunday	10:30
Wednesday 26th	Twilight	18:00
<b>Friday 28th</b>	<b>Big Friday Evening Sailing - All welcome!</b>	<b>18:00</b>
Sunday 30th	Late Summer Sunday	10:30

# Sailing Secretary's Report

Club racing takes part every Wednesday evening and Sunday morning from the beginning of April, with the exception of special events and championships. Wednesday evening races finish at the end of September but racing on Sunday mornings continues right through until the end of the year (1st January). In addition to the normal club racing, through the winter months from January to April, for those hardy enough, and weather permitting, we run the winter Snowman series on Sunday mornings.

For members not wishing to race, Friday evenings are very popular with novice sailors, cruising sailors and racers looking for a little practice. Friday evening sessions run from April until the end of September.

New for 2018, special event races will be run on a Saturday afternoon, instead of Sunday morning, with a late start and will then be followed by Supper in the club.

For the full calendar, and start times, see the on-line calendar at <http://paigntonsailingclub.co.uk/home/whats-on/> which is continually kept up-to-date.

All sailing activities, racing and social/training rely on volunteers to operate. Racing requires safety crew as well as a race officer and an assistant. Social sailing and training also need safety crews on the water. The club also hosts a number of championships every year and these also need help manning. Specifically volunteers are needed for help on the committee boat, safety boats, help on the shore and in the galley. To help organise these roles, the club use an on-line volunteering program, **DutyMan** (see Dutyman pages). Please take a look at the calendar and put your name down to help wherever you can. Anyone can help, regardless of experience. The more people who are willing volunteer, the better the club runs, so please help if you can. I hope you all have a really good 2018 season on the water.

**Nick Ripley** Sailing Secretary



# Racing Courses

Course Number 1  
(Windward-Leeward)

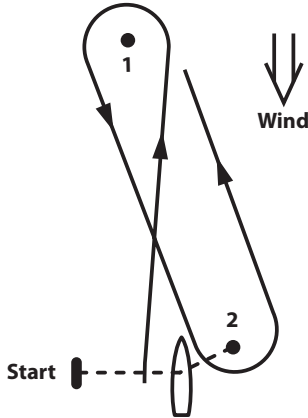

Course Number 2  
(Triangle)

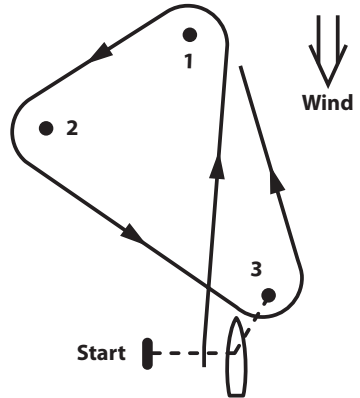

Course Number 3  
(‘P’ Course)

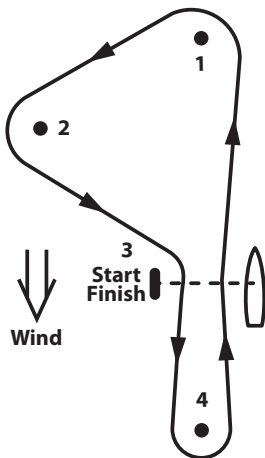

Course Number 4  
(Triangle-Sausage)

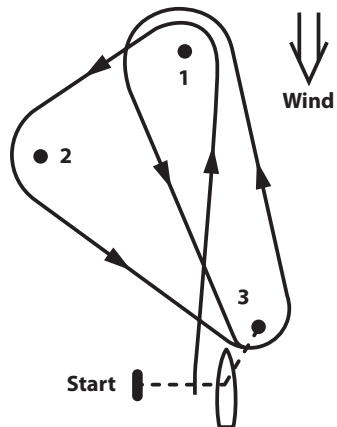

20 1998-2018  
ANNIVERSARY

# Bayside Marine



'Celebrating 20 Years in Chandlery 1998-2018'



Rope  
Chain  
Barton  
Anodes  
Fenders  
Lewmar  
Electrical  
Plumbing  
Hardware  
Lifejackets  
VHF Radios  
Deck Fittings  
Books & Charts  
Paints & Varnish  
And Much More....

Competitive Prices - Two Floors  
Free Parking - Free Local Delivery  
Rope Splicing Service - Flare Disposal\*  
Friendly Knowledgeable Staff - Loyalty Scheme



[www.baysidemarine.co.uk](http://www.baysidemarine.co.uk)

Higher Net Store, Higher Furzeham Road, Brixham, Devon. TQ5 8Q



<b>October</b>	<b>Event</b>	<b>Time</b>
Sunday 7th	Autumn Sunday	10:30
Sunday 14th	Autumn Sunday	10:30
Sunday 21st	Autumn Sunday	10:30
<b>Saturday 27th</b>	<b>Princess of Wales 14.00-16.00 / Sailing Supper 18:30-20:30</b>	

<b>November</b>	<b>Event</b>	<b>Time</b>
<b>Saturday 3rd</b>	<b>RTYC – Junior Regatta</b>	
<b>Sunday 4th</b>	Autumn Sunday / <b>RTYC – Junior Regatta</b>	10:30
<b>Sunday 11th</b>	<b>Commodores Cup/Commodores Roast 13.30 - 15.30</b>	<b>10:30</b>
<b>Saturday 17th</b>	<b>Prize Giving</b>	<b>19:30</b>
Sunday 18th	Autumn Sunday	10:30
Sunday 25th	Autumn Sunday	10:30

<b>December</b>	<b>Event</b>	<b>Time</b>
<b>Sunday 2nd</b>	<b>South West Winter Series - Christmas Cracker</b>	<b>12.00</b>
<b>Wednesday 5th</b>	<b>AGM</b>	<b>19.30</b>
Sunday 9th	Christmas Cracker	11.00
<b>Saturday 15th</b>	<b>Christmas Party</b>	<b>19.30</b>
Sunday 16th	Christmas Cracker	11.00
Sunday 23rd	Christmas Cracker	11.00
<b>Wednesday 26th</b>	<b>Boxing Day Christmas Cracker</b>	<b>11.00</b>

<b>January 2019</b>	<b>Event</b>	<b>Time</b>
<b>Tuesday 1st</b>	<b>New Years Day Christmas Cracker</b>	<b>11.00</b>
Sunday 6th	Snowman	11.00
Sunday 13th	Snowman	11.00
Sunday 20st	Snowman	11.00
<b>Sunday 27th</b>	<b>Starcross Steamer</b>	

<b>February 2019</b>	<b>Event</b>	<b>Time</b>
Sunday 3rd	Snowman	11.00
Sunday 10th	Snowman	11.00
Sunday 17th	Snowman	11.00
<b>Sunday 24th</b>	Snowman	11.00







# Treasurer's Report

Having taken on the role of treasurer in December at the AGM, I can tell you it is a full on job. You have people handing you receipts, invoices, cash, cheques and queries left, right and centre! With that, we introduced the Order Requisition Forms and I have to take the hard approach, no form, no payment, otherwise what was the point of creating the form?

For the first few months of the role I looked at places where we could save money, our broadband was swapped onto a cheaper contract with unlimited use, our bin with Virador was swapped to multiple bins which now provide recycling so reducing our monthly fee with them.

I have also learnt everything has to be balanced, in order for the club to make money we have to spend money. In January 2018 we undertook a bar refurbishment and refreshed the products we sold, this is in the hope members will enjoy the new products but also give the club a better profit margin.

So what can the members do to help save money? Please remember to turn off the lights if you are not using them, recycle as much as possible and finally if you need to buy something for the club come and speak to me first!

**Dale Giles** Treasurer

# Membership Report

Membership numbers have been increasing in recent years and it is great to see the club so busy. In 2016 Membership topped 242, which is the highest for some years and an increase from 182 in 2015. The largest increase in membership is in the junior section, so great work from Paul and all the Junior team.

The club is run for its members by its members and with the increasing numbers the club requires more help to ensure all events are properly staffed.

Helping out is a great way to get to know more people at the club, and help is often required both on and off the water and there are always experienced club members to help and guide you. So, if you fancy helping out on safety boats, galley duties, on the green at events or helping organise social events let me know and I will put you in touch with the right people.

Make sure you spread the word about the Club to friends and family and bring them down to our 'push the boat out' event to try out sailing for their selves. Don't forget you can use your membership card to pre-load with money to pay for food, drinks and boat hire. This is very popular with parents putting some money on their junior's cards and means you do not have to bring money to the club when out sailing.

Here's looking forward to some great Sailing for 2018.

**Jules Cronk** Membership Secretary

# SELL your property with us for



Call us to book your **FREE** no obligation property appraisal on **07970 228581** or email **[Michael.parsons@hatched.co.uk](mailto:Michael.parsons@hatched.co.uk)**

\*£495 fee applicable when you select our 'Standard' fee package and you use Hatched Conveyancing





# About The Club

## **Objectives**

The objectives of the club are described in the club's constitution. The club is a not-for-profit organisation and a registered amateur sports club dedicated to providing the facilities for the enjoyment of sailing by members of the local community. It does this by providing organised racing and by teaching adults and children to sail. The club is a recognised RYA training centre and beginners are given further training to develop their skills to the point where they can enjoy racing. The social aspect of sailing is also encouraged with the holding of regular social events and the availability of a social category of membership.

## **Management**

The club is managed by the General Committee which consists of four flag officers (Commodore (Chair), Vice Commodore, Rear Commodore Social and Rear Commodore Sailing), three officers (Treasurer, Secretary, and Sailing Secretary) and seven members. The committee meets monthly and its minutes can be read. All members of the committee are elected annually at the Annual General Meeting held in early December. The sailing activities are run by the Sailing Committee chaired by the Rear Commodore Sailing and the social side is run by the Social Committee chaired by the Rear Commodore Social. Before each season starts a programme of sailing, training and social events is published. The club relies on the running of championships and open meetings to keep its financial head above water. Championships are organised by the Championship Committee.

## **Rules and Bye-laws**

All members are expected to comply with the rules and bye-laws of the club. The rules and byelaws can be found at the back of the club's constitution. The General Committee can write new bye-laws if it considers it necessary to meet new situations and deals, as it sees fit, with members who break club rules. The main rules and bye-laws are summarised as follows:

## **Behaviour**

Members are expected to behave in a manner which is not injurious to the interests of individuals or the club. Examples of unacceptable behaviour could be physical or verbal abuse, foul language, drunken behaviour, deliberate damage to club property, cheating to gain competitive advantage, repeated failure to carry out rostered duties etc.

## **Duties**

Sailing members rostered for duties must carry them out, unless they have arranged an exchange with another member. In addition to rostered duties members are expected to help event organisers with the running of important events such as championships.

## **Pets**

Members can bring their dog(s) into the club as long as they are well behaved and stay towards the pool table end of the clubhouse. If a dog causes damage to the club the owner will be liable for repairs and/or cleaning.

## **Guests**

Members are permitted to bring guests into the club, who must be entered in the visitor's book held behind the bar. A maximum of three guests may be signed in at any one time and an individual guest can be signed in no more than six times in one year. Guests wishing to use the sailing facilities may do so no more than three times before applying for sailing membership.

## **Club Notice-boards**

Any member wishing to display a notice on a club notice-board must seek approval from the club secretary who will sign and date it. 'For sale' notices can be displayed for a maximum of three months.

## **Security**

Any member who is last to leave the premises must ensure all lights are out, heaters are switched off, the alarm is re-set and all doors are locked.

## **Notice Of Race**

Organising Authority: Paignton Sailing Club, South Quay, The Harbour, Paignton, UK.

**Event:** 2017 Club Racing Series' and Club Racing Special Events

The races will be governed by the rules as defined in The Racing Rules of Sailing. All PY rated dinghies and cruisers are eligible to race if all crew are members of Paignton Sailing Club – for Special Events, the crew need not be members of Paignton Sailing Club, crew may also sail on no more than six days if they are not Paignton Sailing Club members. The Sailing Instructions will be available on the club website and at the club at least one week before the first start of the first race of the series. RRS 40 (personal buoyancy) and the meaning of some race signals will be changed in the Sailing Instructions.

The courses to be sailed and all other information regarding the series will be published in the Sailing Instructions. The schedule of races is as defined in this program.

# Using DutyMan

We use DutyMan, an online, interactive and dynamic duty roster. Using this system allows members to log in and view the dates when we need support.

## Using this system provides the following advantages:

1. Duty notifications are automatically sent out by email
2. Duty swaps can be arranged between members
3. Swaps are automatically updated and become visible to all
4. Availability for a duty can be confirmed online

## Duty Allocation

Duties are allocated twice a year, at the end of April and the end of July. This allows new members to be added to the roster in their first year. If each eligible member does four duties per year, this allows us to run a full racing calendar.

Reminders of the impending allocations will be sent out in the Club newsletter.

Duties for events such as external championships are *not* counted towards club duties, but members are encouraged to volunteer for these too, and they are available on the DutyMan calendar.

The racing calendar and eligible membership list are added to DutyMan as soon as they are finalised, so members wishing to reserve dates for duties early can do so before the April allocation. Similarly, members wishing to block out dates when they know they will be unavailable can email [duties@paigntonsailingclub.co.uk](mailto:duties@paigntonsailingclub.co.uk) before the allocation to avoid clashes with holidays or outside commitments.

When new members are added, DutyMan sends out an automated email with login credentials. Please keep this email, as it contains a link which will take you directly to your own page on DutyMan.

## Duty Swaps

Please remember that if you cannot attend your duty, it is your responsibility to arrange a swap.

The online Duty Roster provides a facility which allows you to request swaps via email. Multiple requests can be sent out as only the first positive response will be accepted. Alternatively, a swap can be arranged verbally or via the

### **Procedure to swap or volunteer for a duty:**

Click the link in the introductory email you received from DutyMan. This should log you in automatically.

You will be taken to a web page with a set of options on the right hand side ('What do you want to do next?'). The top two are 'Request a duty swap' and 'Volunteer for a duty'. Choose your option. Choose a date from the calendar on the left hand side, and click the 'Request swap' or 'Volunteer' button on the bottom. You can also write a message to those concerned which is copied to the DutyMan administrator.

You can make multiple requests to swap the same duty, only the first acceptance will matter.

---

If you receive a request to swap a duty, please help out if you can.

Please help the Club to keep a full roster: for instance, if you only sail on Wednesdays but are allocated a Sunday, please arrange a swap before Wednesday sailing is finished for the season.

If sailing is cancelled for weather or attendance reasons, members with duties on that day may be allocated duties for later in the season if there are empty slots.

The club can only manage to operate such a full and successful calendar with the support of all its members. We thank you for your cooperation!

If you need any support, please contact us at:

**duties@paigntonclub.co.uk** and we will do our best to answer any queries.

**Sam Garwood** Duty Rota Manager



**CASH REGISTERS · EPOS · CCTV**

**Prompt Service With Excellent After Sales Support**

**Torquay 01803 313222 or 0800 181694**

**www.cashregisters-devon.com**



Where local people  
**recommend**  
*quality* and *trustworthy*  
businesses

Helps you avoid  
Cowboys and Rogue Traders



**OUR LOCAL** *Expert*.co.uk

Not online?

**Call Nick: 01626 249 979**  
for your free printed guide

### **Our Local Expert – did you receive your free copy?**

Our Local Expert is a free guide which only features businesses that have been used and recommended by local people. This means you can expect a trustworthy and good quality service from anyone listed – reducing the fear of ‘cowboys’ and ‘rogue traders’.

If you haven't received one, please contact Nick Hall on 01626 249979, [Nick@OurLocalExpert.co.uk](mailto:Nick@OurLocalExpert.co.uk) and he will be happy to post you a copy.

Nick also welcomes recommendations of local businesses you use and trust, using the same contact details.

# TROY MITCHELL TILING

COMMERCIAL & DOMESTIC WALL AND FLOOR TILING  
Ceramic, Slate, Terracotta, Porcelain,  
Marble & Natural Stone

*Dare to be Different*

**Telephone: 01803 613619**

**Mobile: 07768 737266**

107 Marldon Road, Shiphay, Torquay  
Devon TQ2 7EG

 TROY MITCHELL TILING

**[www.troymitchelltiling.co.uk](http://www.troymitchelltiling.co.uk)**

quote reference PSC2018 when booking a tiling job to receive 10% off the total price

# Paignton Junior Sailing Club

**Paignton Junior Sailing Club (PJSC)** provides structured social sailing, tuition and race training for youngsters. Our aims are to promote dinghy racing by encouraging youngsters to have fun out on the water in safety and to enjoy the thrill of dinghy sailing. We are the junior section of **Paignton Sailing Club**.

**Training Courses** - Our courses (RYA stage 1 and 2) have been highly commended by the **Royal Yachting Association (RYA)**. **PJSC** use the facilities of the training centre and the main club to run courses and activities for its young people. Our training courses are run to the RYA syllabus and coached by fully qualified dinghy instructors with safety support at all times. The **RYA** junior courses in 2018 start on Friday 8th June for 5 weeks (Friday evenings)

**Junior Sailing Night** - Throughout the year (April to October) **PJSC** run supervised sailing with safety cover on Friday nights. These sessions start at 6.00 and close at 9.00 with a £5.00 fee for sailors using club boats. These sessions are for general sailing taking place close to Paignton beach with longer sail aways to Goodrington and Preston beaches or Broadsands when conditions are suitable. There are no absolute entry requirements to participate although we encourage all juniors to complete our junior course and achieve **RYA level 1** as a minimum. Junior Friday night sailing starts in April. We use a "whatapp" group to provide weekly updates on the plan and likely conditions for Friday night sailing.

**PJSC** has a fleet of club dinghies comprising of 6 Toppers, RS Tera, 3 RS Fevas and 2 RS Visions. For Friday night sailing we have a flat charge of **£5.00** for juniors using club boats. This is paid on registration each week.

**Progression into racing** - As a club we encourage transition into racing and for those interested introduce race practice as part of the Friday night sailing. At **PJSC** we support participating in local racing opportunities and advancing into **RYA Zone and National Squads**. The main single handed fleet is the 'Topper' with a strong core of juniors regularly racing locally and at national level. Owning your own boat can have many advantages when moving onto racing and we can advise on what boat and potentially local boats that may be coming up for sale so please speak to us.

**Club racing** – Juniors can participate in all club racing which runs on Sunday mornings and Wednesday evenings (April to October). There is no charge for club toppers being used in club racing. Wednesday evening racing is increasingly popular with a separate "Junior start" (start 18.30).

**Paul Procter** - Junior coordinator – juniors@paingtonsailingclub.co.uk

Over the last 4 years we have been very active in supporting the **South West Youth Sailing Academy** (SWYSA). **SWYSA** is a not for profit organisation that arranges additional training opportunities available to youngsters from local clubs throughout the winter months. This is a great social interactive group between youngsters from various clubs and provides high quality training when most clubs scale back junior sailing over the winter months.

Be a part of **PJSC** - **PJSC** needs parents, guardians and older juniors to help with the running of the junior club and to provide additional support boat crew and on shore help. For this purpose there is an annual planning event with occasional ad hoc meetings of an informal committee to shape the activities and support required throughout the year.

The Junior Coordinator is the key contact and can be contacted on the following e-mail **juniors@paigntonsailingclub.co.uk**

**Membership of Paignton Junior Sailing Club** – Junior membership is £25.00 however we also stipulate that at least one parent/guardian is also a member or associate member (£25.00). Membership can be processed using our on-line membership page on the **Paignton Sailing Club** website. **www.paigntonsailingclub.co.uk**



# Training

**Training Coordinator** – Jackie Gater - training@paigntonsailingclub.co.uk

**Paignton Sailing Club** is affiliated to the **Royal Yachting Association** and has been accredited with Recognised Training Centre status. As such, the venue is inspected annually to confirm that **Paignton Sailing Club** complies with the required standards of safety and teaching.

**The training** side of Paignton Sailing Club is run under the Operating Procedures which can be found under “Documents & Instructions” on our website. The document covers general policy statements, such as Health and Safety, Equal Opportunity, and Child Protection. Furthermore, it provides detailed information about safety afloat whether training, racing, cruising or powerboating.

**The Club** offers a wide range of **RYA** courses led by a team of qualified instructors and can deliver Youth Training Stages 1-4, Adult Learn to Sail Level 1-3 plus Day Sailing, Spinnaker Handling, Seamanship, Racing and Performance sailing. **PSC** also offers Powerboat Training Level 1 – 2 and Safety Boat Training. The club runs Assistant Instructor, Instructor and Senior Instructor courses as the need arises.

**In addition** to sailing and powerboat courses, the club can arrange First Aid, Short Wave Radio (VHF), Racing Coach, Race Officer Training and Mark Laying courses, on request, at very reasonable prices.

**Details** of all our courses can be found on the "Learn to Sail & Training Courses" page on the website.

## **Adult: dinghy sailing training dates** (provisional)

April 2018 - 28th and 29th – Beginners Level 1

June 2018 - 16th and 17th – Beginners Level 1

July 2018 – 21st and 22nd – Beginners / moving up

September 2018 - 15th and 16th – “moving up” - level 1+ / level 2

## **Junior training** : beginners stage 1 and stage 2

8th June – 5 consecutive Fridays 18.00 -21.00





# Sailing Photography

Championship and Club Events

[www.stevecayley.photography](http://www.stevecayley.photography)

  
Steve Cayley  
Photography



"The Art of Sailing" - selected for 2018 RYA Calendar



## Foot Pain? We'll get you back on your feet.



The Society of  
Chiropractors  
and Podiatrists

[www.hpcpc-uk.org](http://www.hpcpc-uk.org)



TORBAY  
FOOTCARE

9 Dendy Road, Paignton, TQ4 5DB

01803 521880

[www.torbayfootcare.co.uk](http://www.torbayfootcare.co.uk)



# Safety afloat

1. A support boat shall be launched and manned for any sailing activity organised by the club. Support boats will be manned by two persons when carrying out support duties and have on board all designated support and first aid equipment. If racing, an extra support boat must be launched if the wind is in excess of 20 knots or there are more than 25 boats. Volunteers for this must be sought at the time.
2. A buoyancy aid shall be worn by any person taking part in a club organised activity afloat.
3. No racing shall take place unless the committee boat crew and support crews can maintain radio contact with each other.
4. The decision not to sail in the event of poor conditions will be taken by the principal race officer in case of racing, and the senior instructor in the case of training.
5. A number of dinghies owned by the club are available for hire with the permission of a club officer or instructor. Members who use this facility shall book them out and in. Hired dinghies shall not go afloat unless support boats are available.
6. Club members who take part in casual sailing (sailing not organised by the club) do so entirely at their own risk but are expected to show responsibility for the safety of themselves and others. This includes wearing buoyancy aids and taking into account the prevailing conditions, the forecast and the competency of themselves and their crews. If unsure of the conditions they should seek the advice of an experienced club sailor or the harbourmaster.

## Assisted Sailing

Aimed at our more inexperienced sailors and juniors, assisted sailing takes place either on a Friday evening or Saturday morning. The club boats are available for all members to use so that you can practice your sailing skills or just get out on the water in the knowledge that there are experienced sailors and support boats on hand to make sure everyone is safe. The club boats are available to hire for a small fee, but if you have your own boat you are still welcome to join in. Keep an eye on the club website for more information about when these sessions occur.

# Boat Hire

## **The Boats we have are:**

2 RS Visions, 3 RS Fevas, 6 Laser Picos, 6 Toppers, 1 Laser with Standard, Radial or 4.7 Rig

## **How to rent a boat:**

Fill out the 'Boat Hire form' on the Race Notice Board outside the Gents changing rooms, ask a committee member for permission or any queries with rigging. Collect a boat and enjoy! After sailing **please pay at the bar.**

## **Boat Hire Prices**

RS Vision £15

RS Feva £10

Laser Pico £5 per person

Topper £5 per person: Free to juniors participating in racing

Laser £10 per person

## **Use of club boats**

For insurance purposes, non-members are not permitted to board, hire or borrow club boats unless approved by an officer of the club.

## **Club Opening Times**

Full members may use the changing facilities at any time. Club front door keys may be purchased from the bar.

## **Bar Opening Times**

Wednesdays 19:30 – 23:00

Fridays 19:30 – 23:00 after activities

Sundays 12:00 – 14:00

## **Dinghy Berths**

To apply for a boat parking space, please send an email to Graham Slater at: [sailing@paigntonsailingclub.co.uk](mailto:sailing@paigntonsailingclub.co.uk)

## **Damage to PSC Boats & Equipment**

Members are required to report damage to club boats, equipment or premises to the Bosun:

Fred Whitehead 01803 521259 or a Club Officer as soon as possible.

# Hire of The Clubroom for Private Functions

If you fancy hosting a party or need to organise a meeting then our club room, with it's beautiful views over Paignton Harbour and Tor Bay, is available for hire at very reasonable rates. We have space for about 70 people with both fitted and flexible seating arrangements and a large screen TV/monitor if required. There is a fully stocked bar with friendly bar staff, as well as a large kitchen with hob, oven, microwave, fridge, dishwasher, crockery and cutlery for your use. If you don't want to cook, then we can put you in contact with our experienced catering team. Room hire basic charge is £25-, the remaining depending on bar takings, and please note our bar prices are very reasonable. Email our secretary for details: [secretary@paigntonsailingclub.co.uk](mailto:secretary@paigntonsailingclub.co.uk)



# TJ's



# Restaurant

PAIGNTON HARBOUR

Rustic fine dining with a relaxed friendly atmosphere

Introducing our **NEW Exciting European Inspired A La Carte Menu** using local produce lovingly prepared. Exquisitely designed, palate-pleasing and creatively presented.



-  Panfried Fresh Fish from Brixham Market
-  Local Shellfish with Expertly Infused Ingredients
-  High Quality Succulent Meats cooked to Perfection
-  Innovative Vegetarian Flavours

For reservation or enquiry  
**Call 01803 527389**

Email: [info@tjsrestaurant.co.uk](mailto:info@tjsrestaurant.co.uk)  
[www.tjsrestaurant.co.uk](http://www.tjsrestaurant.co.uk)



**tripadvisor**

Rated 5 stars from over  
1000 reviews on Trip Advisor







Service Centre and Stockists able to offer  
you full factory warranty back-up on:

**Honda, Mercury, Mariner &  
Tohatsu Outboards,**

**MerCruiser Stern Drives  
& Yanmar Diesels Inboards**

**New & Used Boat and Engine Sales**



**HONDA  
MARINE**



**honda** save



**IAB**



**MERCURY  
Outboards**



**TOHATSU  
Outboards**

**MERCURY  
MerCruiser**



**YANMAR**



**Whaly  
BOATS**



Tonto Marine, Dartside Quay, Galmpton TQ5 OGA,  
Tel. 01803 844399 Mob. 07770 69 61 63  
[www.tontomarine.co.uk](http://www.tontomarine.co.uk), [enquiries@tontomarine.co.uk](mailto:enquiries@tontomarine.co.uk)