

ALLEN

DESIGN RODOLFO DORDONI



Struttura: in legno multistrati con molleggio garantito da cinghie elastiche ad alta componente di caucciù. Traversi di rinforzo in metallo.

Preparazione della struttura: in poliuretano espanso a quote differenziate ad alta densità. Imbottitura bracciolo e schienale realizzata con inserto schiumato ignifugo con quota morbida per conferire confort e sofficià. Ulteriore rivestimento in fibra termolegata di forte spessore ed accoppiata con tela di cotone bianca.

Cuscinatoria: imbottitura cuscino seduta in piuma d'oca canalizzata con inserto centrale in poliuretano espanso ad alta resilienza. Cuscini schienale totalmente imbottiti in piuma d'oca canalizzata.

Piedini: appoggio a terra tramite piedini (disegno esclusivo Minotti Studio) stampati in alluminio pressofuso e verniciati color Peltro con finitura extralucida anti-touch. Scivolante protettivo in Hytrel® (gomma morbida antigraffio).

Sfoderabilità: rivestimento sfoderabile solo in tessuto. Rivestimento in pelle fisso solo per la struttura, cuscini schienale e seduta sfoderabili.

Structure: multi-ply wood frame with seating suspension guaranteed by elastic straps with a high rubber content. Metal reinforcements set crosswise.

Structure preparation: let into high-density polyurethane foam in different densities. Arm and backrest padding with soft fireproof foam insert for enhanced softness and comfort. Additional thick fiber lining thermally bound to a white canvas.

Cushions: channeled goose down filling for the seat cushions with very resilient polyurethane foam central insert. Channeled goose down for the backrest cushions.

Feet: molded aluminum die-cast feet (exclusive design by Minotti Studio), Pewter colored paint with extra-glossy anti-touch finish. Protective Hytrel® (soft, scratch-proof rubber) glides.

Covers: fully removable fabric covers. Non-removable leather for the structure, removable leather backrest and seat cushion covers.

Gestell: aus Schichtholz, Federung garantiert mit elastischen Riemen mit hohem Kautschukanteil. Metallquerstreben.

Aufbereitung des Gestells: unterschiedlich dick geschäumtem, hochdichtem Polyurethan. Arm- und Rückenlehne mit feuerfester, besonders weicher Schaumeinlage, die Komfort und Schmiegsamkeit garantiert. Weitere Beschichtung mit extradicker, wärmesensibler Faser kombiniert mit weißem Baumwolltuch.

Kissen: Sitzkissen mit kanalisierter Daunenfüllung mit zentraler Einlage aus hochelastischem PU-Schaum. Kissen der Rückenlehne mit kanalisiert belüfteter Daunenfüllung.

FüÙe: Bodenaufgabe durch FüÙe aus Aluminiumpressguss (exklusives Minotti-Design), Zinnfarben hochglanzlackiert mit Schutzbeschichtung gegen Abdrücke. Gleitschutz durch Hytrel® (weicher, kratzfester Gummi).

Abziehbarkeit: Nur der Stoffbezug ist abziehbar. Fester Lederbezug nur am Gestell, Rückenlehnen und Sitzkissen sind abziehbar.

Structure : en bois contreplaqué, suspension garantie par des courroies élastiques à teneur élevée en caoutchouc. Traverses de renfort en métal.

Préparation de la structure : en polyuréthane expansé à hauteurs différenciées et haute densité. Rembourrage des accoudoirs et du dossier réalisé avec un insert en mousse ignifuge à hauteur souple pour donner confort et moelleux. Ulérieur revêtement en fibre thermoliée de forte épaisseur et couplé à de la toile de coton blanche.

Coussins : rembourrage du coussin de l'assise en plume d'oie canalisée, avec insert central en polyuréthane expansé à haute résilience. Coussins du dossier entièrement rembourrés en plume d'oie canalisée.

Pieds : pieds d'appui au sol (dessin exclusif Minotti Studio) estampés en aluminium moulé sous pression et peints couleur Étain, finition ultrabrillante anti-trace de doigts. Patin de protection en Hytrel® (caoutchouc souple antiéraflure).

Déhoussage : seul le revêtement en tissu est déhoussable. Le revêtement en cuir de la structure est fixe, celui de coussins, dossier et assise est déhoussable.

FINITURA PIEDINI FEET FINISH

ALLUMINIO | ALUMINUM

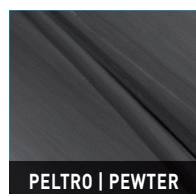

DIVANO | SOFA

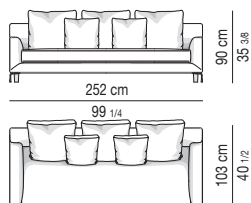
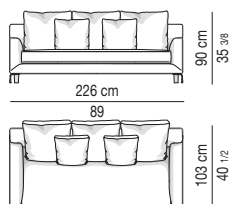
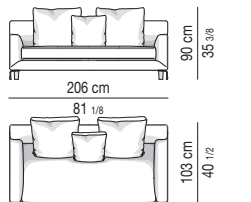
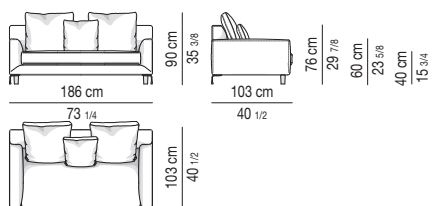

DIVANO COMPOSTO | TWO ELEMENTS SOFA

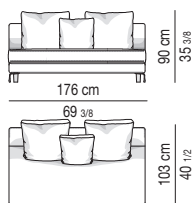
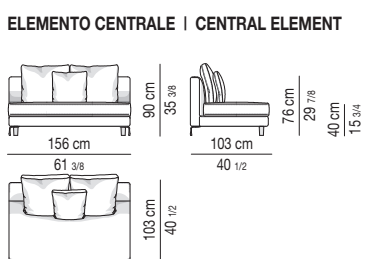
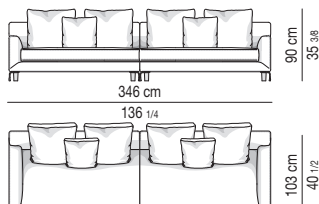
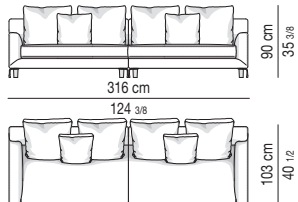
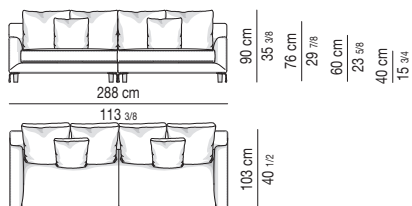

ELEMENTO TERMINALE | ELEMENT WITH 1 ARM

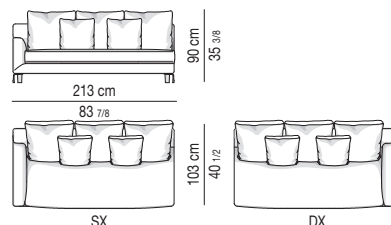
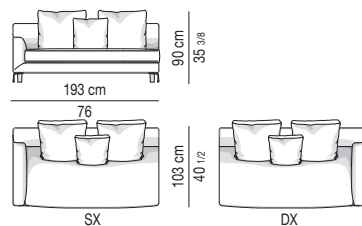
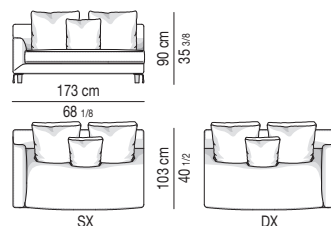
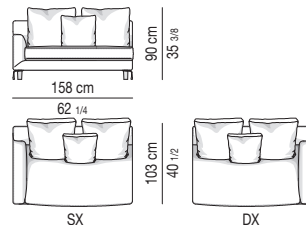
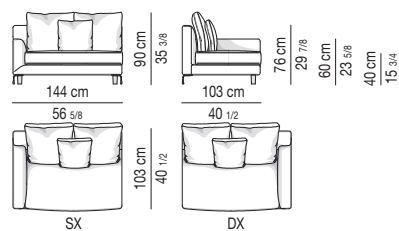

ELEMENTO CENTRALE | CENTRAL ELEMENT

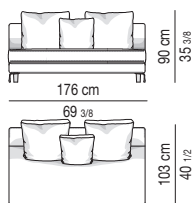
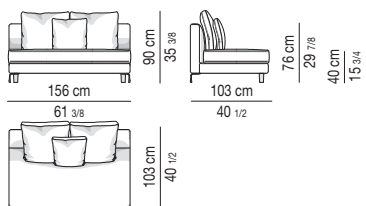

Minotti

CHAISE LONGUE

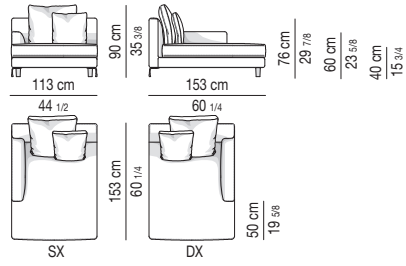

DIVANO-CHAISE LONGUE TERMINALE SOFA-CHAISE LONGUE WITH 1 ARM

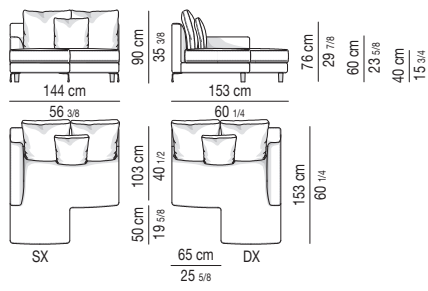

DIVANO CHAISE LONGUE | SOFA-CHAISE LONGUE

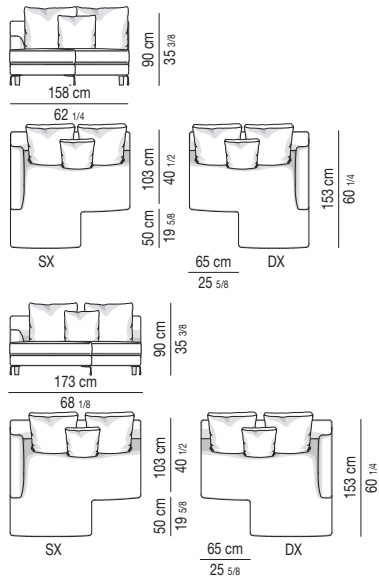
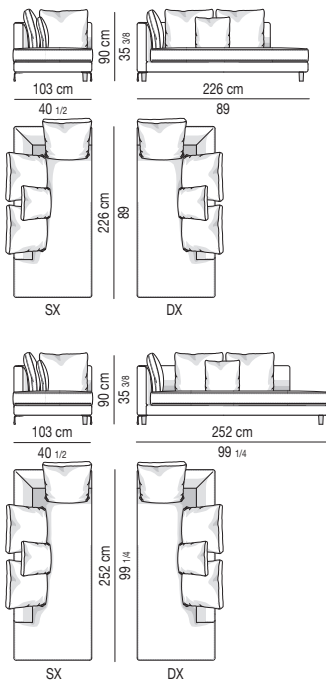

Minotti

DIVANO ANGOLARE | CORNER SOFA

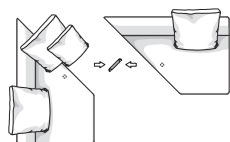
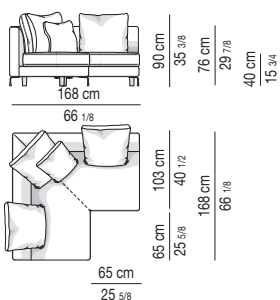

IL DIVANO ANGOLARE CM 168X168 È COMPOSTO DA 2 ELEMENTI UNITI TRA LORO TRAMITE UN SISTEMA DI AGGANCIAMENTO.

THE CORNER SOFA CM 168X168 IS COMPOSED OF 2 ELEMENTS CONNECTED THROUGH LINKING DEVICE.

DIVANO ANGOLARE CON PENISOLA CORNER SOFA WITH OPEN ELEMENT

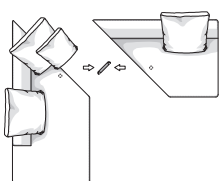
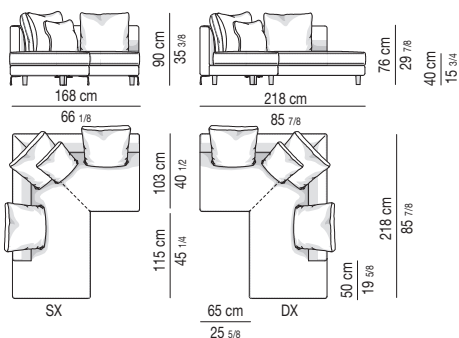

IL DIVANO ANGOLARE CON PENISOLA CM 168X218 È COMPOSTO DA 2 ELEMENTI UNITI TRA LORO TRAMITE UN SISTEMA DI AGGANCIAMENTO.

THE CORNER SOFA WITH OPEN ELEMENT CM 168X218 IS COMPOSED OF 2 ELEMENTS CONNECTED THROUGH LINKING DEVICE.

SOFA PENISOLA SENZA BRACCIOLO OPEN-END SOFA WITHOUT ARMREST

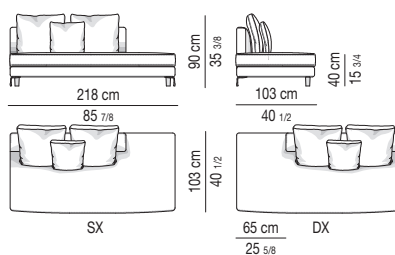

SOFA PENISOLA CON BRACCIOLO OPEN-END SOFA WITH ARMREST

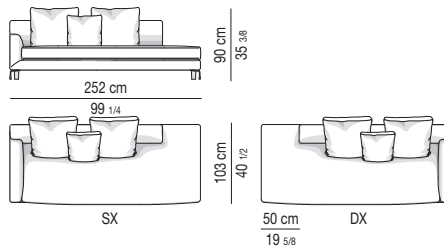
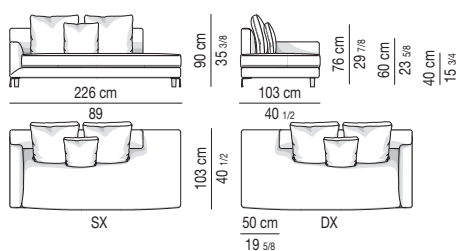

POUF | STOOL

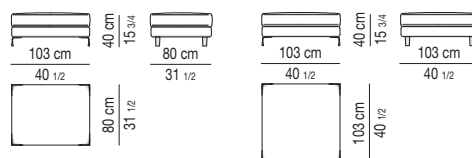

CUSCINO OPTIONAL | OPTIONAL CUSHION

