

# CABINET INSTRUCTIONS

## ⚠ SAFETY TIPS:

- Ensure that the cabinet is positioned square and firm on the floor so that it will not fall over. Some cabinets are equipped with adjustable floor levelers. Adjust the levelers for maximum stability and proper alignment. (The levelers may have unscrewed unevenly during shipment.)
- Some cabinets include a Safety Strap. Follow the instructions included with the Safety Strap to ensure maximum stability. (See step #4)
- Do not allow climbing on cabinets.
- Keep plastic bags and small parts away from children.

## CABINET SET UP:

1. Turn the adjustable floor levelers located on the bottom of the cabinet all the way in (up) (Figure 1). Be sure to include the support(s) located in the center of some cabinets.
2. Inspect the inside of the cabinet, carton and packaging to make sure you have removed all separately packed parts. Do NOT dispose of any packing material until the set up is complete.
3. Move the cabinet to its final location. Do NOT put any items on shelves or racks until finished with the set up instructions.

### Attach units together (available on some models): (TWO PEOPLE RECOMMENDED)

TOOLS REQUIRED: screwdriver (not included)

- a) Locate hardware pack of #8 x 1" screws and #8 x 2-1/4" screws.
- b) Locate holes in the Top Front Rail and Top Back Rail, from inside of the unit (Figure 2).
- c) Determine the unit arrangement according to the diagram of your Personal Storage Cabinet.
- d) Position the Base Unit near its final location. (Figure 3)
- e) Position the Second Unit on top of the Base Unit. (Figure 3)
- f) Confirm the units are straight front-to-back and side-to-side.
- g) Secure the units together with the enclosed screws, from inside of the unit. (Figures 2, 3 & 4)

Use 1" screws to attach the Top Front Rail of the Base Unit with the Bottom Panel of the Second Unit.

Use 2-1/4" screws to attach the Top Back Rail of the Base Unit with the Bottom Panel of the Second Unit.

- h) Repeat above steps as needed to add additional levels to your cabinet.

Refer to any additional assembly instructions that may be included with your cabinet.

## 4. Assemble the cabinet as required.

Some cabinets include a safety strap to prevent tipping. If a safety strap was included with your cabinet, review the instructions included with the safety strap at this time and choose the assembly option which best fits your application. The cabinet should be attached to the wall for maximum stability. If your cabinet does not have this feature, proceed to the next step.

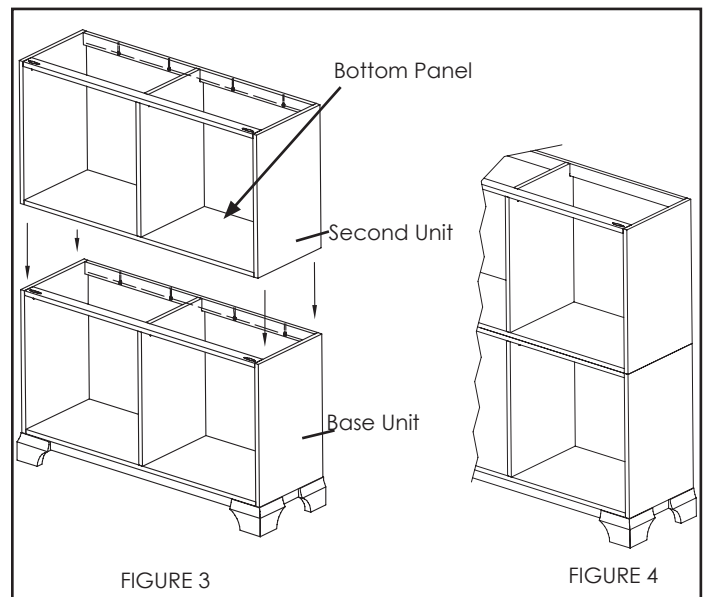
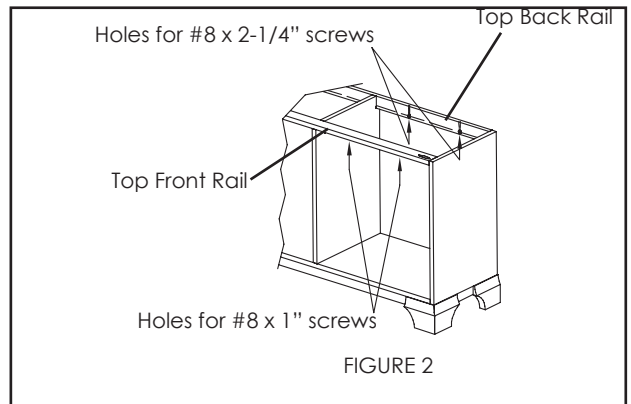
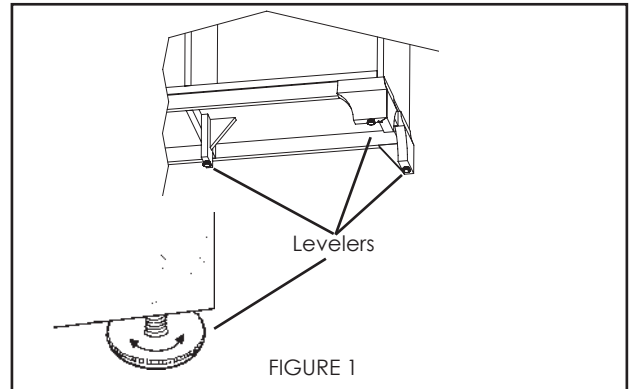

**5. Close and secure the door(s).**

**6. Level the Cabinet.** Place a level alongside the cabinet from front-to-back and side-to-side. There are adjustable levelers under the cabinet (Figure 1) that can be turned in (up) or out (down) to make adjustments. Adjust the levelers until the cabinet is level in all directions, and is square and firm on the floor. (Including the support(s) located in the center of some cabinets.) Note: Allow your cabinet to settle for 48 hours prior to adjusting the alignment of the cabinet doors. If your cabinet doors require realigning, see instructions below.

**REMOVAL OR REPOSITION SHELVES:**

Some of the shelves may be removed or repositioned.

- 1) Remove all items from the shelves.
- 2) Remove the screws from the underside of the shelf clips and shelves. (Figures 5 & 6).
- 3) Remove the shelves.
- 4) Securely place the shelf clips into the desired holes inside the cabinet. There may be several holes that can be used for shelf height adjustment.
- 5) Re-install shelves. Starting at the bottom and working upward, place each shelf onto the shelf clips (Figure 6). Make sure each shelf is level.

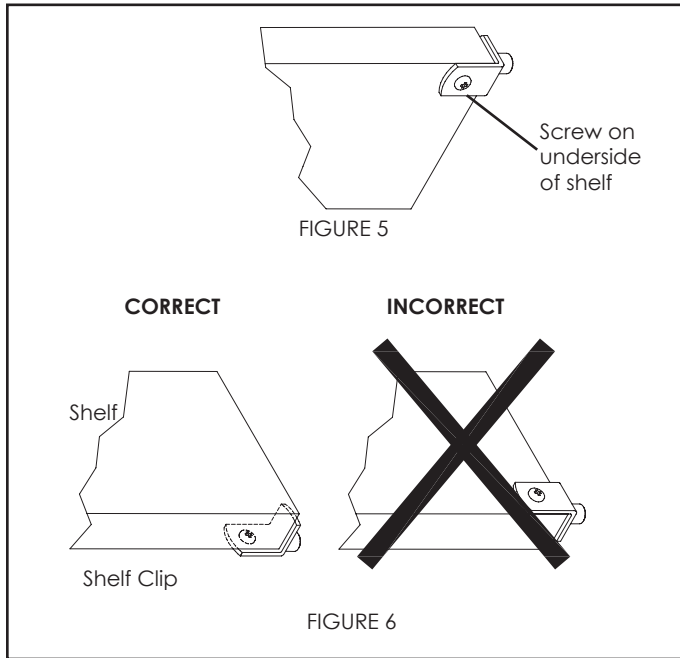

**REALIGNMENT OF DOORS:**

Perform the following steps if the cabinet door rubs when opening or closing the door, or the door appears to not hang properly on the case.

- 1) Follow Step 1 of Cabinet Set Up instructions to ensure the cabinet is level (Figure 1).
- 2) Remove the Cover Plate and adjust the hinges to realign the door in relation to the cabinet frame (Figure 7).
  - Out of square with the case: Turn the Front Screw (Figure 7) in or out as required to align the door with the cabinet. (May need to adjust each hinge independently to reach desired appearance.)
  - Door not flush with case: Loosen the Back Screw (Figure 7) and position the door flush with the cabinet. Retighten the Back Screw.

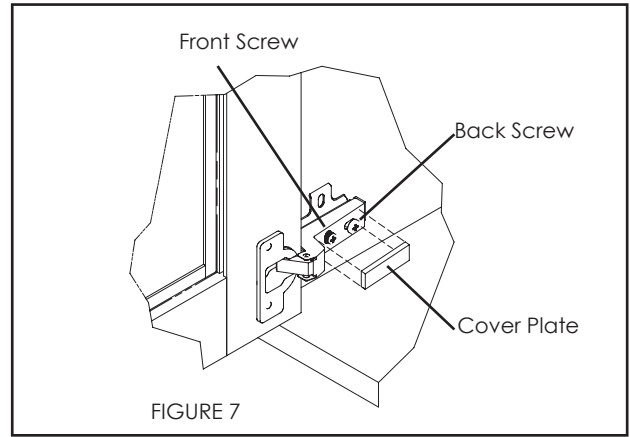

**GENERAL GUIDELINES FOR CABINETRY:**

Protect surfaces from scratches, dents, condensation or spills. Use cutting boards and coasters to protect the surfaces. (Coasters under drink glasses and bottles can help prevent glass rings or stains from occurring.) Wax and polish your cabinet as frequently as you do your other furniture. Use a non-silicone liquid or paste wax. Avoid exposing the cabinet to direct sunlight and protect it from extreme temperatures and humidity changes. Prolonged exposure to direct sunlight may fade the finish while extreme temperature and humidity changes may cause the wood to split or crack. Check periodically that your cabinet is level and rests firmly on the levelers. This is especially important the first few months if the cabinet settles into carpet (Figures 1).

**SERVICE INFORMATION**

Howard Miller offers a limited 1-year warranty on your product from the original date of purchase or date of receipt if the product was a service award. In the unlikely event that your product appears to be malfunctioning or requires repair within the warranty period, please contact your retailer or the company who provided the item if it was an award. They will be your first resource for information regarding your warranty and service options.

If your product is more than one year old from the date of purchase or receipt as an award, your product is no longer under the manufacturer's warranty. Support for products that are no longer under warranty is available through the "Help Center" at [www.howardmiller.com](http://www.howardmiller.com).

We recommend that you carefully read and follow all instructions provided with your Howard Miller product before pursuing service. These instructions will provide detailed information to answer most questions.

To find additional information regarding your product, to order parts or to find a service center, please go to the "Help Center" located at [www.howardmiller.com](http://www.howardmiller.com). The "Help Center" also has links to product manuals, instructions, videos and frequently asked questions.

Before contacting your retailer, award provider or a service center, please have the following information available. The model number and serial number can be found on the Product Information Label which is normally on the back or bottom of the product.

Model Number: \_\_\_\_\_ Serial Number: \_\_\_\_\_  
 Date Purchased: \_\_\_\_\_ Where Purchased: \_\_\_\_\_

If the item was shipped directly to you, it is your responsibility to report freight loss or damage to the carrier and your retailer or award provider. If the carton indicates signs of "visible damage", instruct the driver to note the damage on the freight bill. If damage is found after the item has been delivered, notify your retailer or award provider and the carrier immediately. Many carriers require notification within 2 days. Failure to notify the carrier within their required time frame may waive your rights to a damage claim and you may be liable for the damage.

