

84594

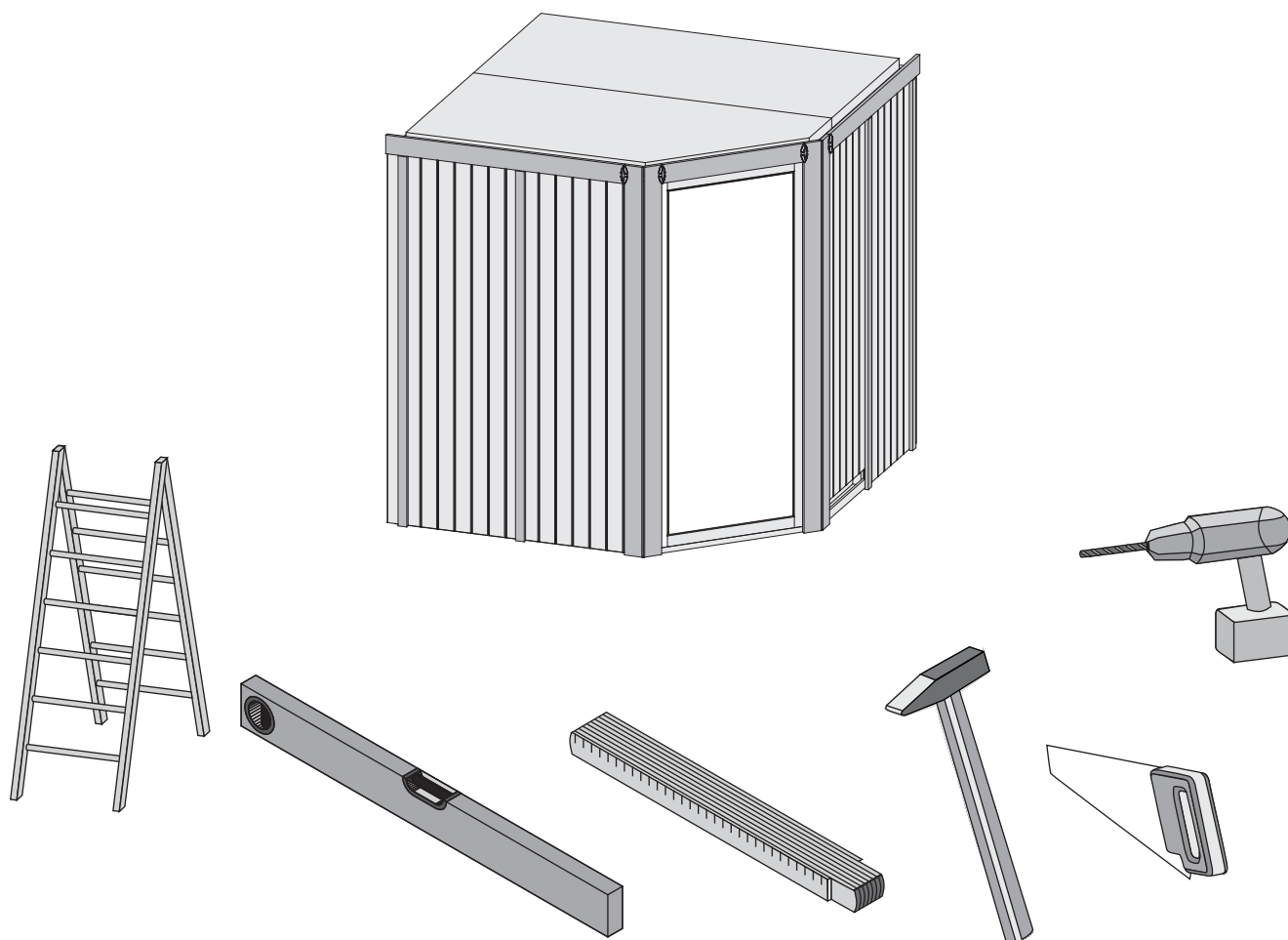

 **Aufbauanleitung**

 **Building Instructions**

 **notice de montage**

 **montagehandleiding**

 **Montagevejledning**

 **Instrucciones de construcción**

 **Istruzioni per il montaggio**

 **Montážní návod**



+49 421 38693 33



Vergleichen Sie zuerst die Material-liste mit Ihrem Paketinhalt! Bitte haben Sie Verständnis, dass Beanstandungen nur im nicht aufgebauten Zustand bearbeitet werden können!



Vergelijk eerst de lijst van materialen met de inhoud van uw pakket! Reclamaties kunnen alleen in behandeling worden genomen zolang de onderdelen nog niet zijn gemonteerd!



Confrontate questa distinta materiali prima con il contenuto del pacchetto! Vi preghiamo di comprendere che eventuali reclami possono essere accolti solo prima del montaggio!



First compare the list of materials with your package contents! Please understand that complaints can be processed in the non-built status only!



Start med at kontrollere materialelisten med indholdet af den leverede pakke! Vi gør venligst opmærksom på at reklamationer kun kan behandles for materialer som ikke er blevet bearbejdet!



Nejprve přezkontrolujte obsah balení podle materiálového listu! Mějte pochopení pro to, že případnou reklamaci se můžeme zabývat pouze tehdy, když díly nebudou smontované! Za pomoci tohoto seznamu můžete jednotlivé díly přiřadit k montážnímu návodu.



Commencez par comparer la liste du matériel avec le contenu de votre paquet! Sachez que nous traitons uniquement les réclamations concernant le matériel à l'état non monté!



En primer lugar, compare la lista de material con el contenido del paquete. Rogamos entienda que las reclamaciones sólo pueden ser tramitadas antes de montar el objeto!

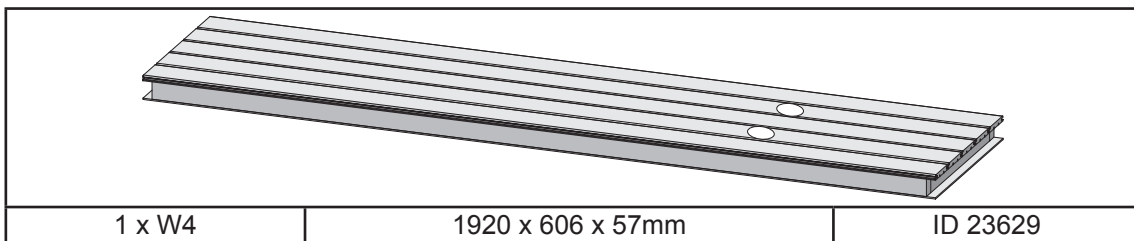
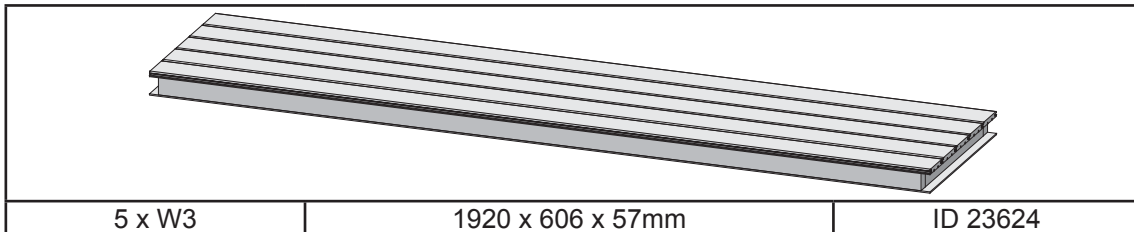
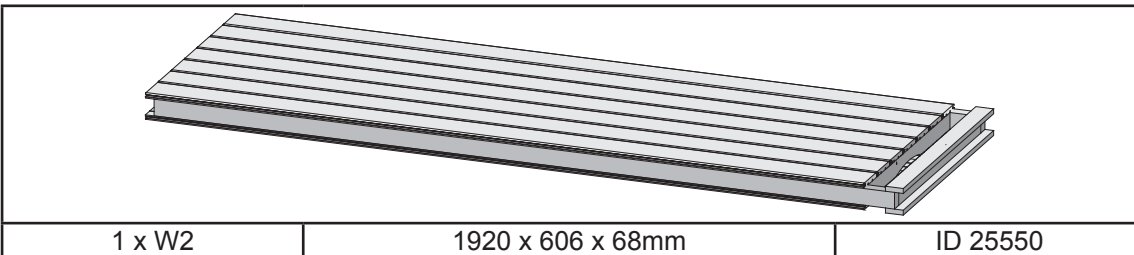
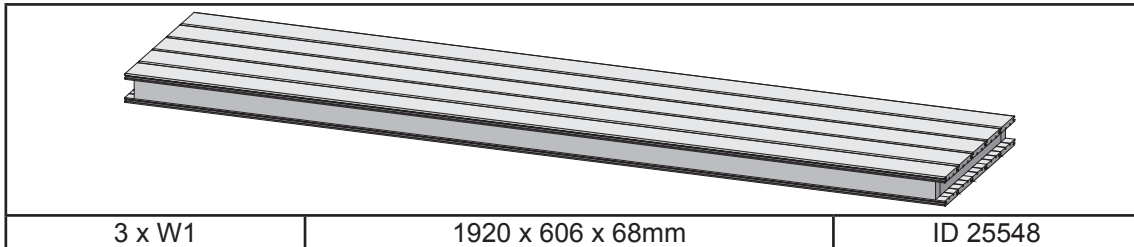
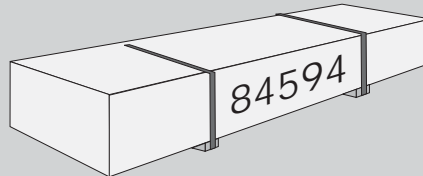

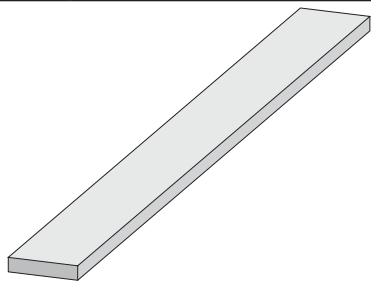

7 x B1	1920 x 19 x 3mm	ID 20799
4 x B2	70 x 45 x 18mm	ID 26366
6 x B3	800 x 45 x 18mm	ID 24796
4 x B4	1884 x 45 x 18mm	ID 48037
4 x B5	480 x 95 x 18mm	ID 20930
4 x B6	580 x 95 x 18mm	ID 16708
1 x B7	765 x 95 x 18mm	ID 26357
2 x B8	1605 x 95 x 18mm	ID 22588
1 x B9	300 x 120 x 18mm	ID 22467
1 x B10	500 x 42 x 28mm	ID 25454
2 x B11	590 x 42 x 28mm	ID 26360
2 x B12	1130 x 42 x 28mm	ID 26361
1 x B13	1759 x 42 x 28mm	ID 24133
2 x B14	1925 x 42 x 28mm	ID 26382
1 x B15	1815 x 42 x 28mm	ID 24098
2 x B16	1841 x 42 x 28mm	ID 26376
3 x B17	1874 x 52 x 52mm	ID 26165

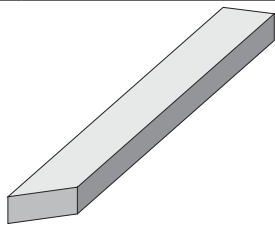

1 x C1	1181 x 42 x 28mm	ID 56627
1 x C2	1209 x 42 x 28mm	ID 56626
2 x C3	1247 x 42 x 28mm	ID 25740
2 x C4	1292 x 42 x 28mm	ID 56306

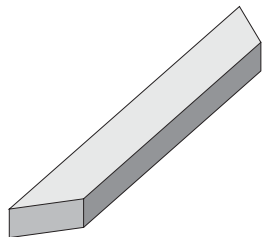

1 x D1	859 x 42 x 28mm	ID 56308
2 x D2	896 x 42 x 28mm	ID 56307

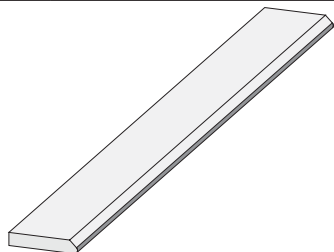

2 x G1	1884 x 58 x 17mm	ID 48521
4 x G2	1980 x 95 x 17mm	ID 48540

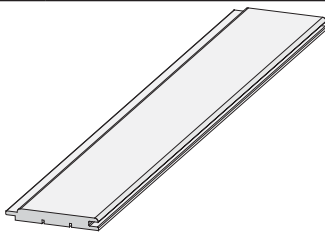

2 x E1	1920 x 97 x 12mm	ID 22863
--------	------------------	----------

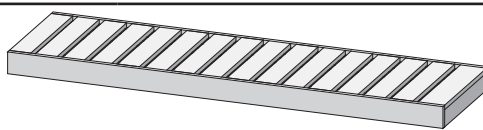

1 x L1	1260 x 500 x 90mm	ID 23399
2 x L2	1810 x 550 x 90mm	ID 21767

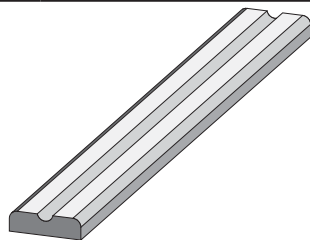

1 x L3	1260 x 90 x 22mm	ID 56629
1 x L4	1310 x 90 x 22mm	ID 26389
1 x L5	1810 x 90 x 22mm	ID 26112

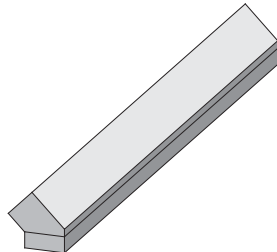

2 x K1	1874 x 76 x 38mm	ID 43464
--------	------------------	----------

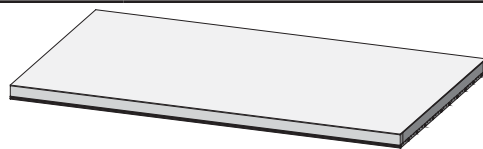

1 x M1	1839 x 918 x 57mm	ID 45230
--------	-------------------	----------

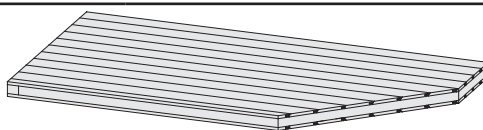

1 x M2	1839 x 918 x 68mm	ID 52839
--------	-------------------	----------

1 x

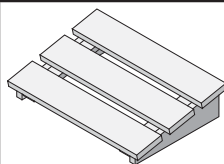

ID 20708

4 x T1

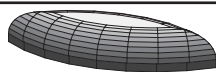

ID 26272

20 x



ID 14005

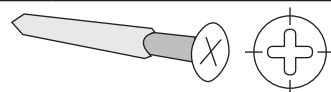

50 x	4 x 30mm	ID 3686
70 x	4 x 50mm	ID 3688
50 x	4 x 70mm	ID 3689
50 x	4,5 x 80mm	ID 9204
20 x	6 x 60mm	ID 14014

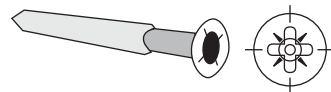

120 x	4,5 x 40mm	ID 26285
-------	------------	----------

6 x S1



ID 14266

120 x S2



ID 26116

3 x S3



ID 42172

10 m

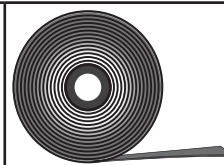

ID 14025

2 x

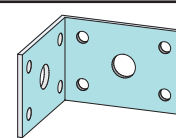

ID 21292

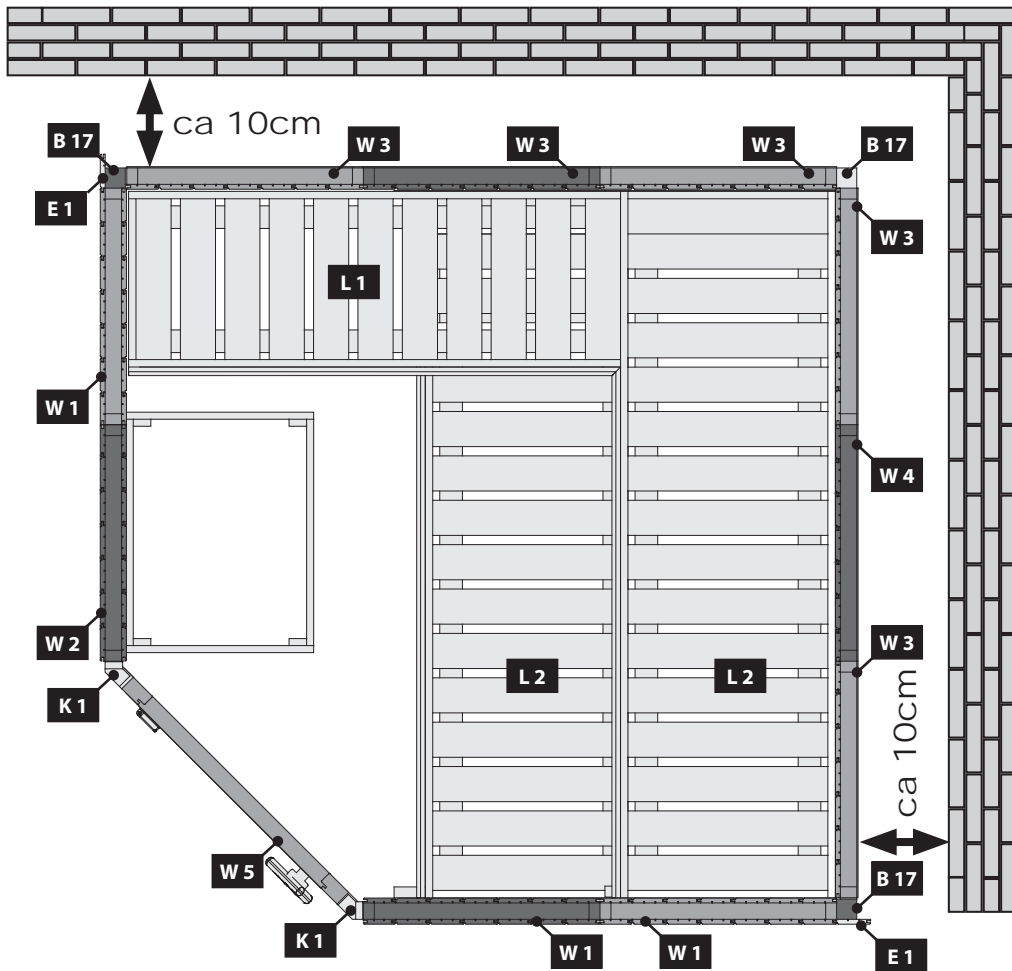
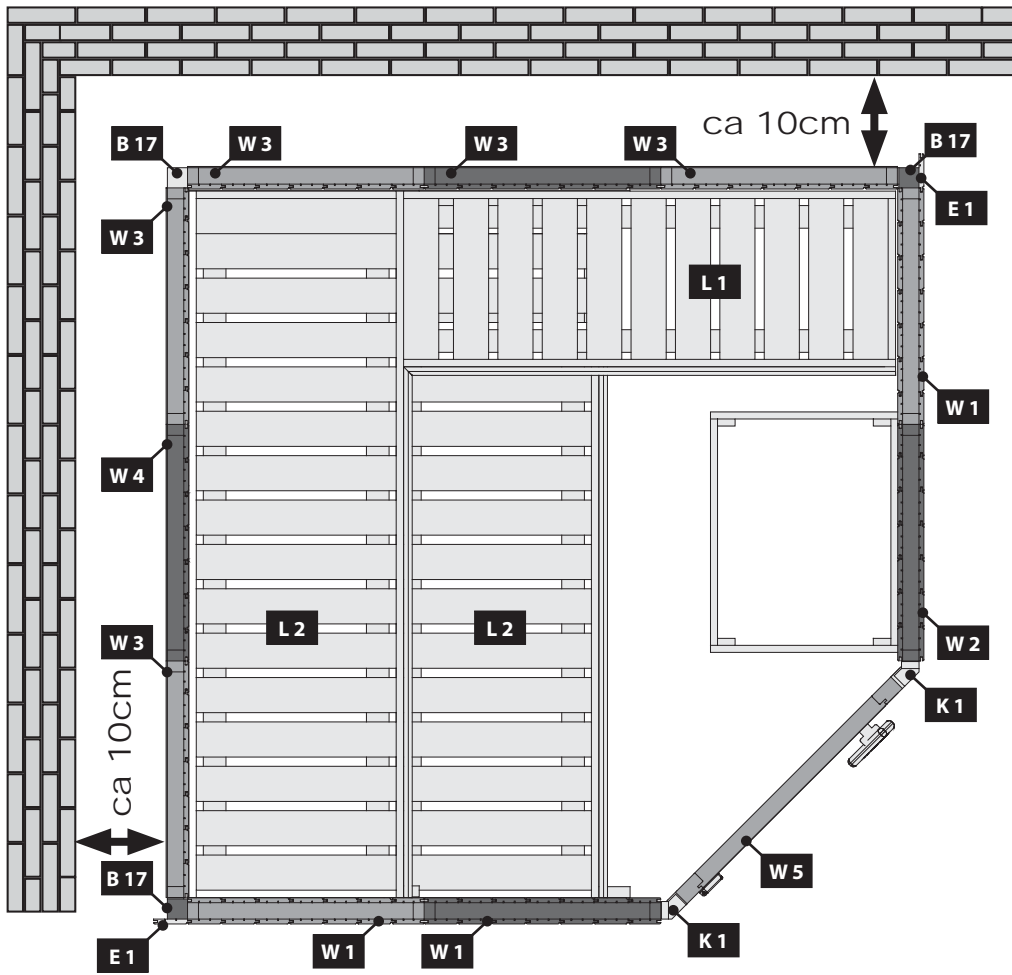

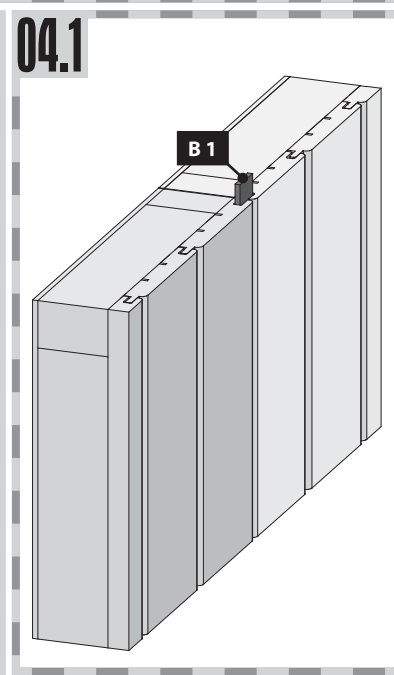
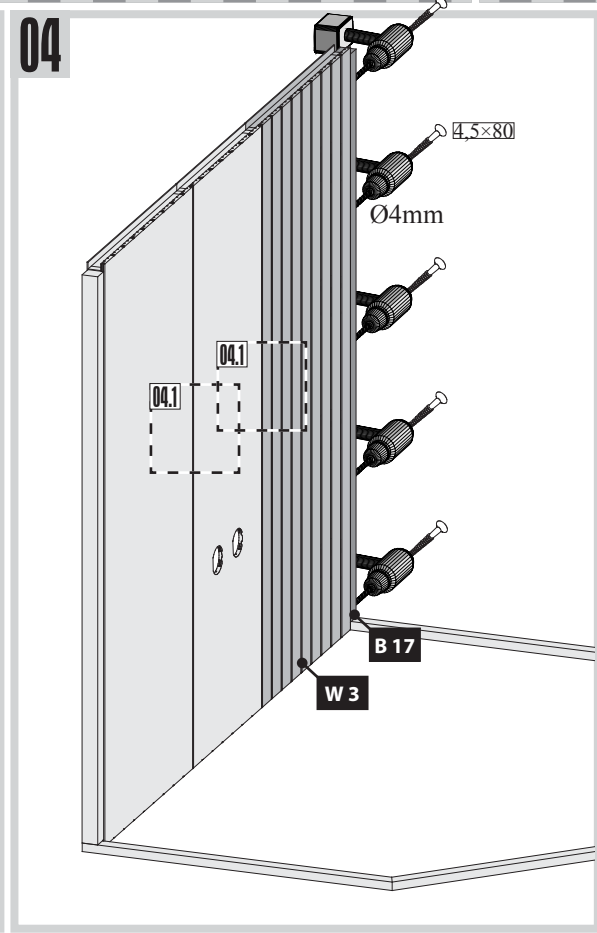
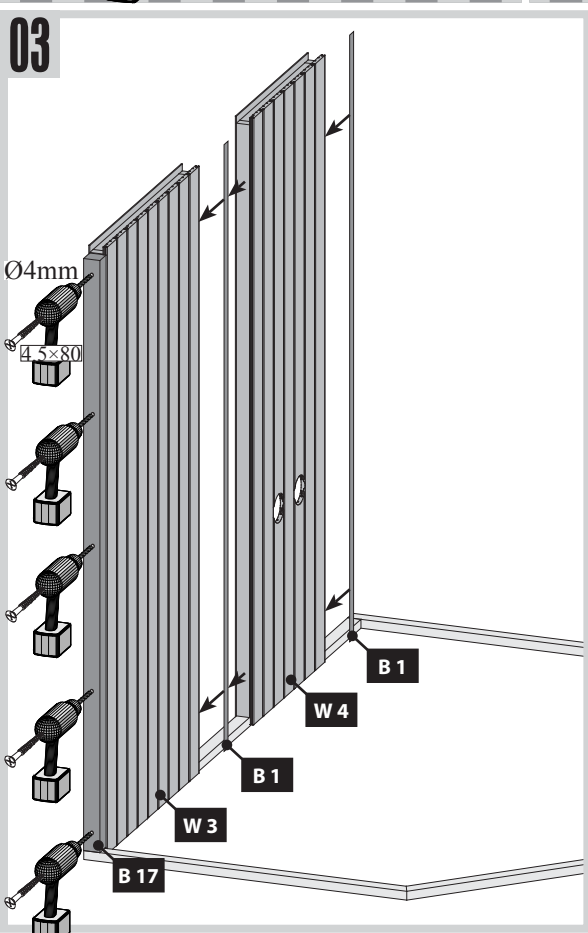
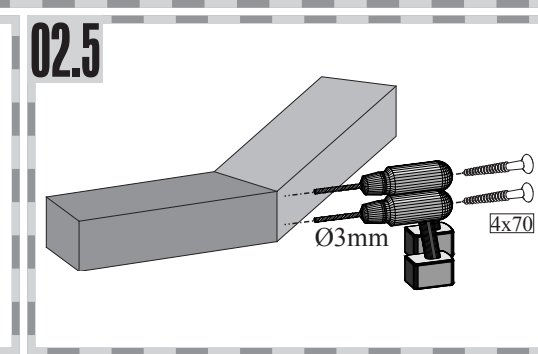
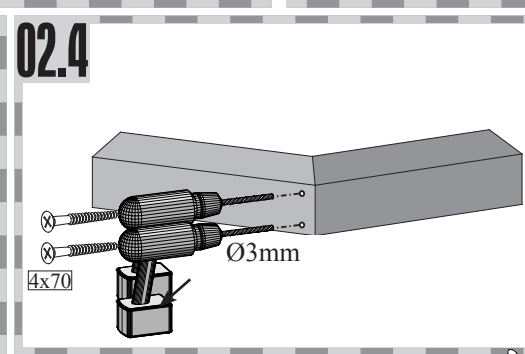
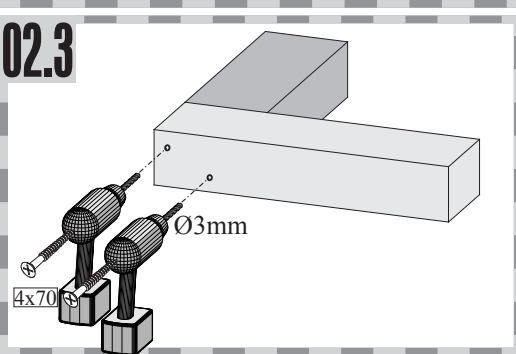
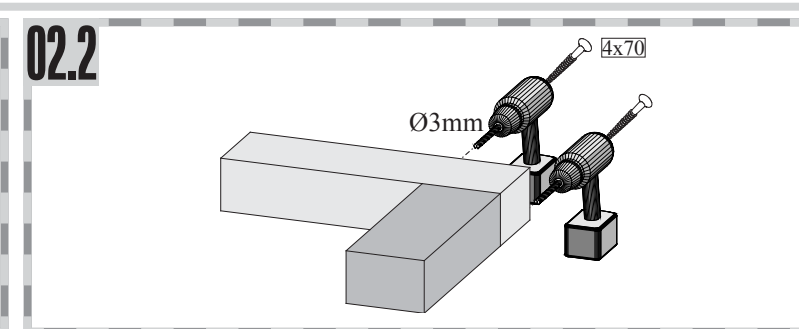
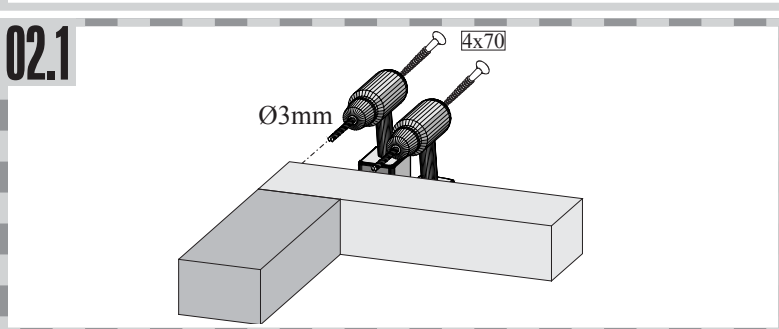
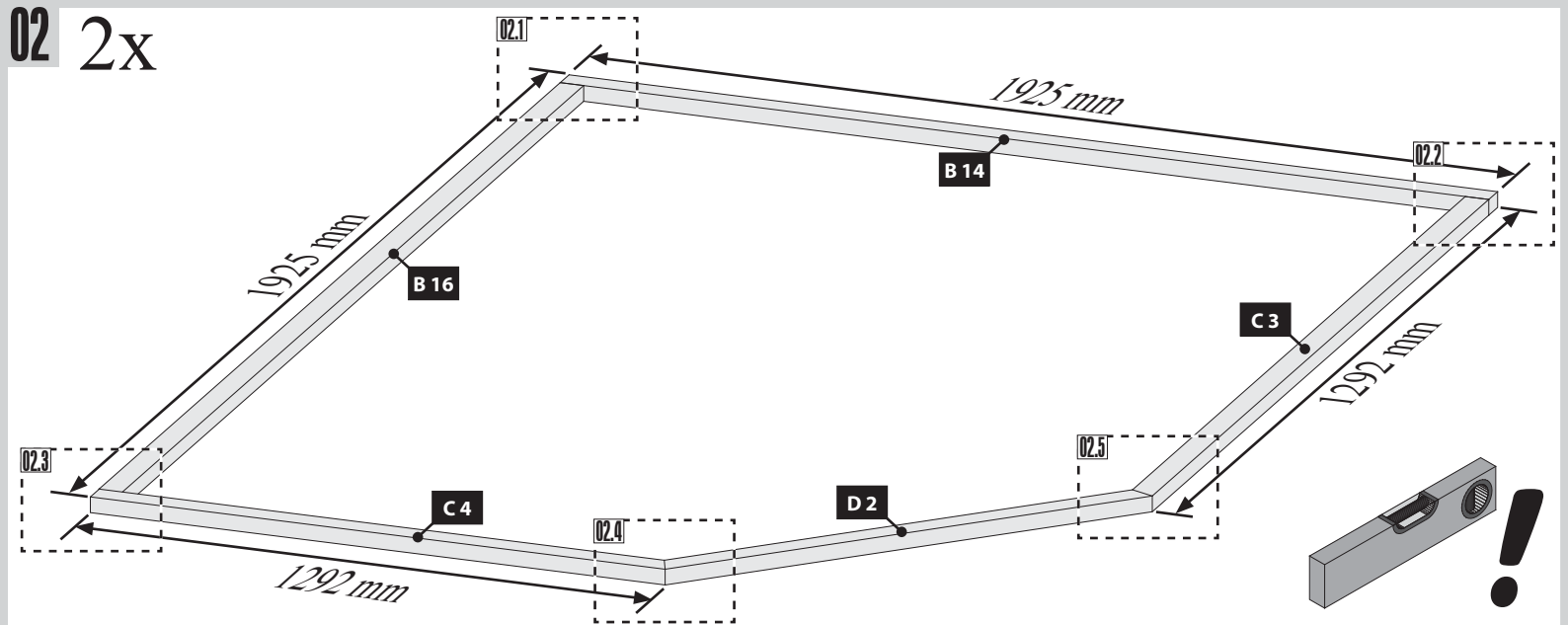

05

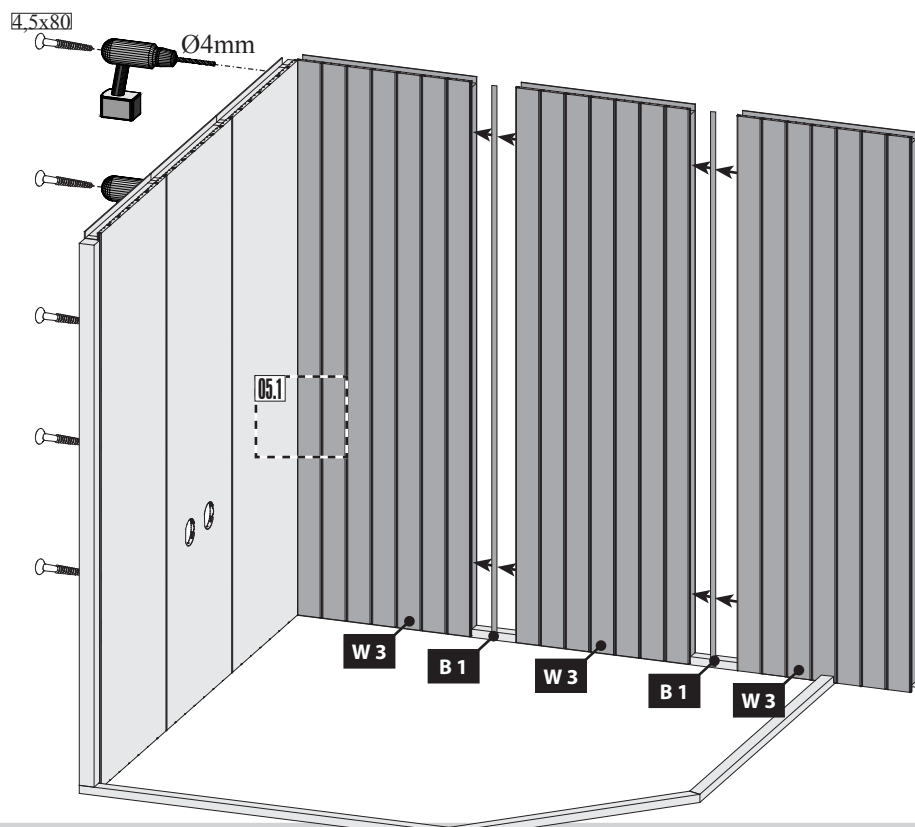

05.1

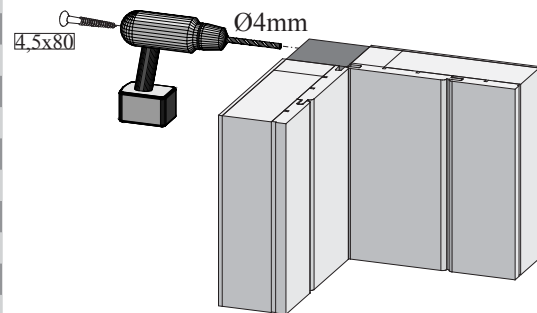

06.1

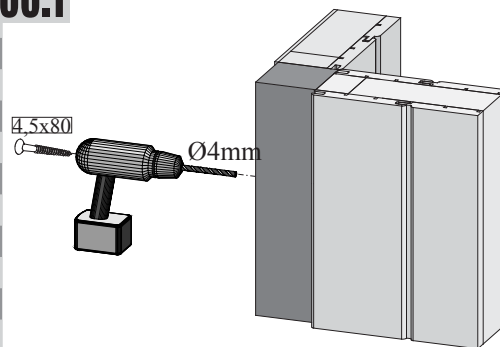

06

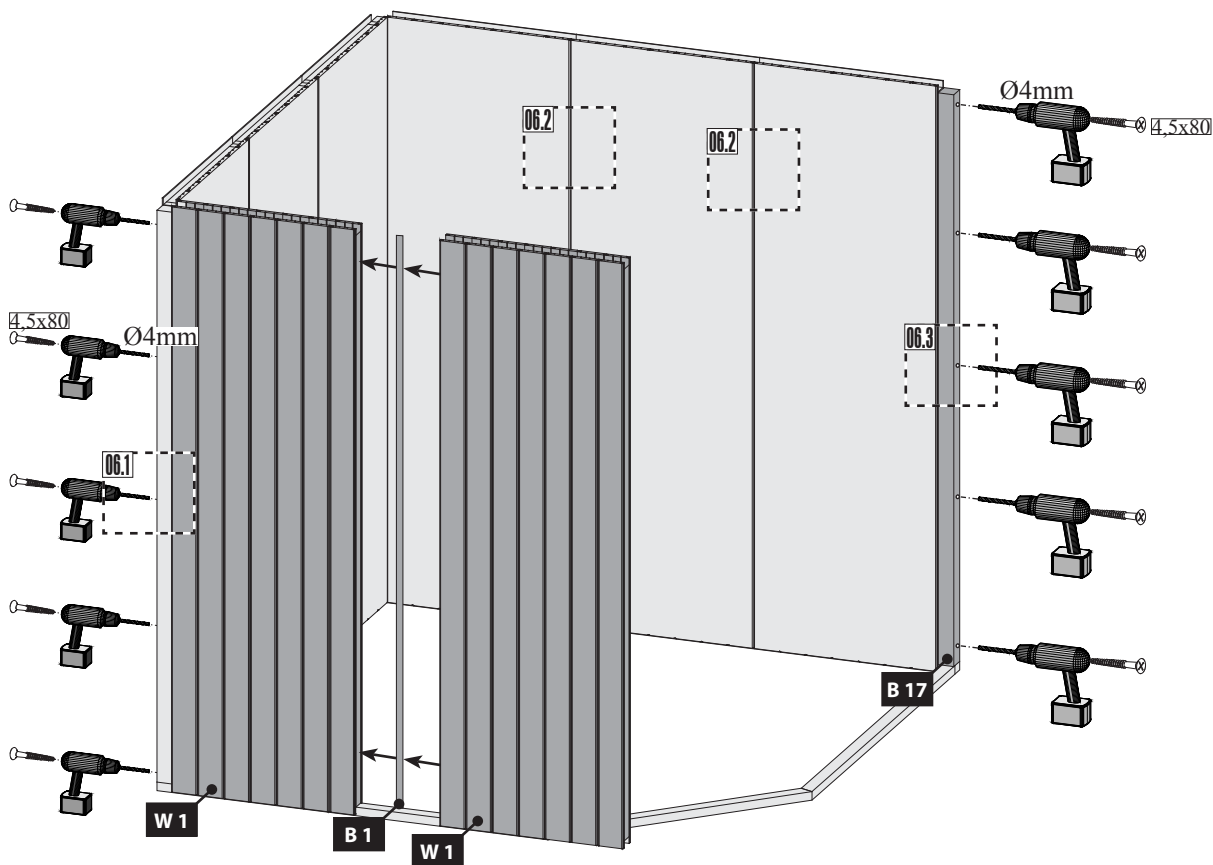

06.2

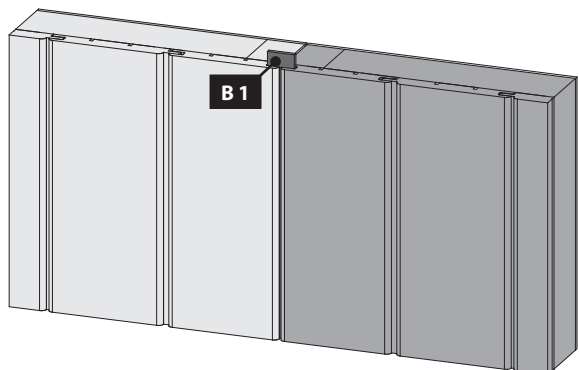

06.3

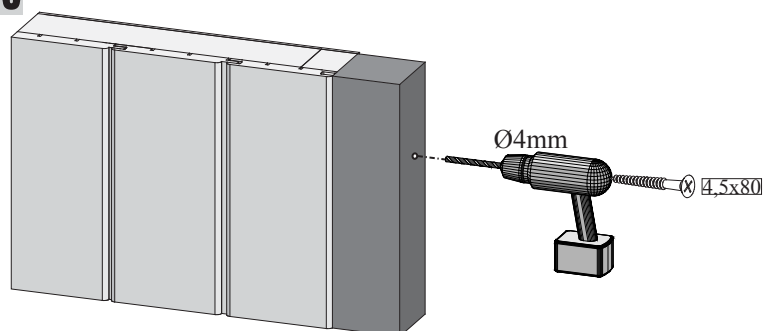

07

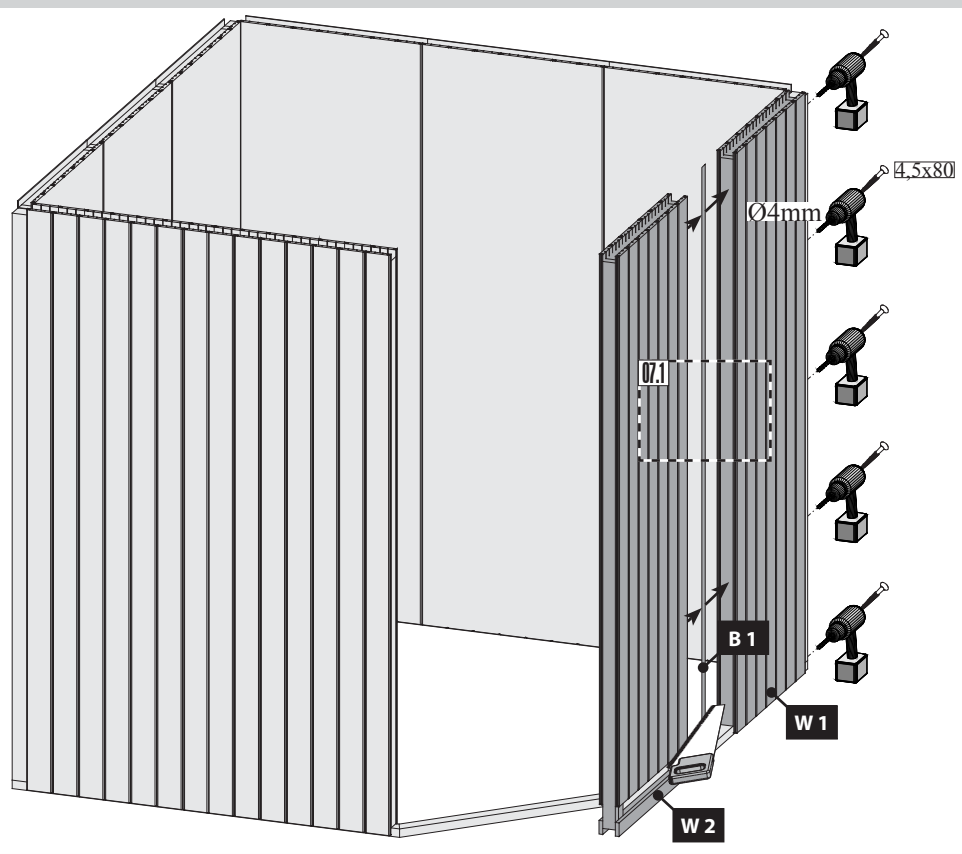

07.1

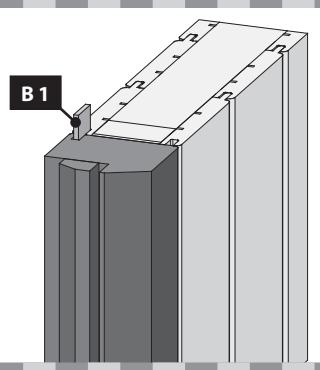

08.1

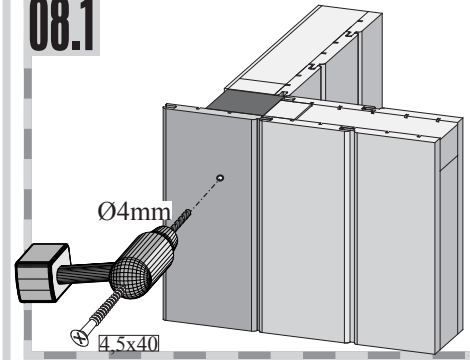

08.2

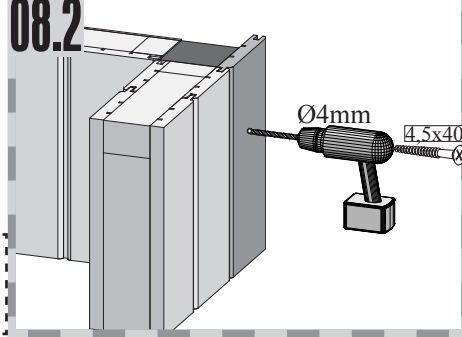

08.3

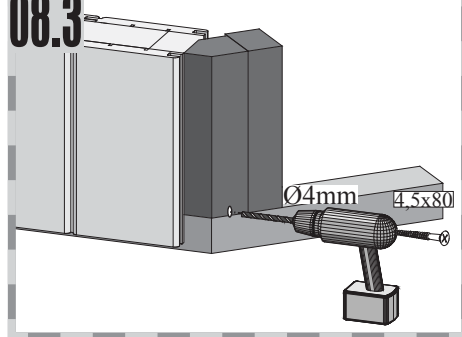

08.4

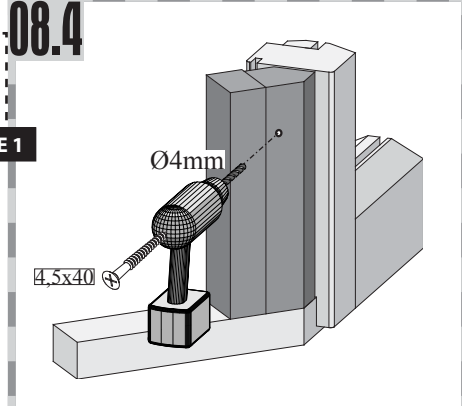

08

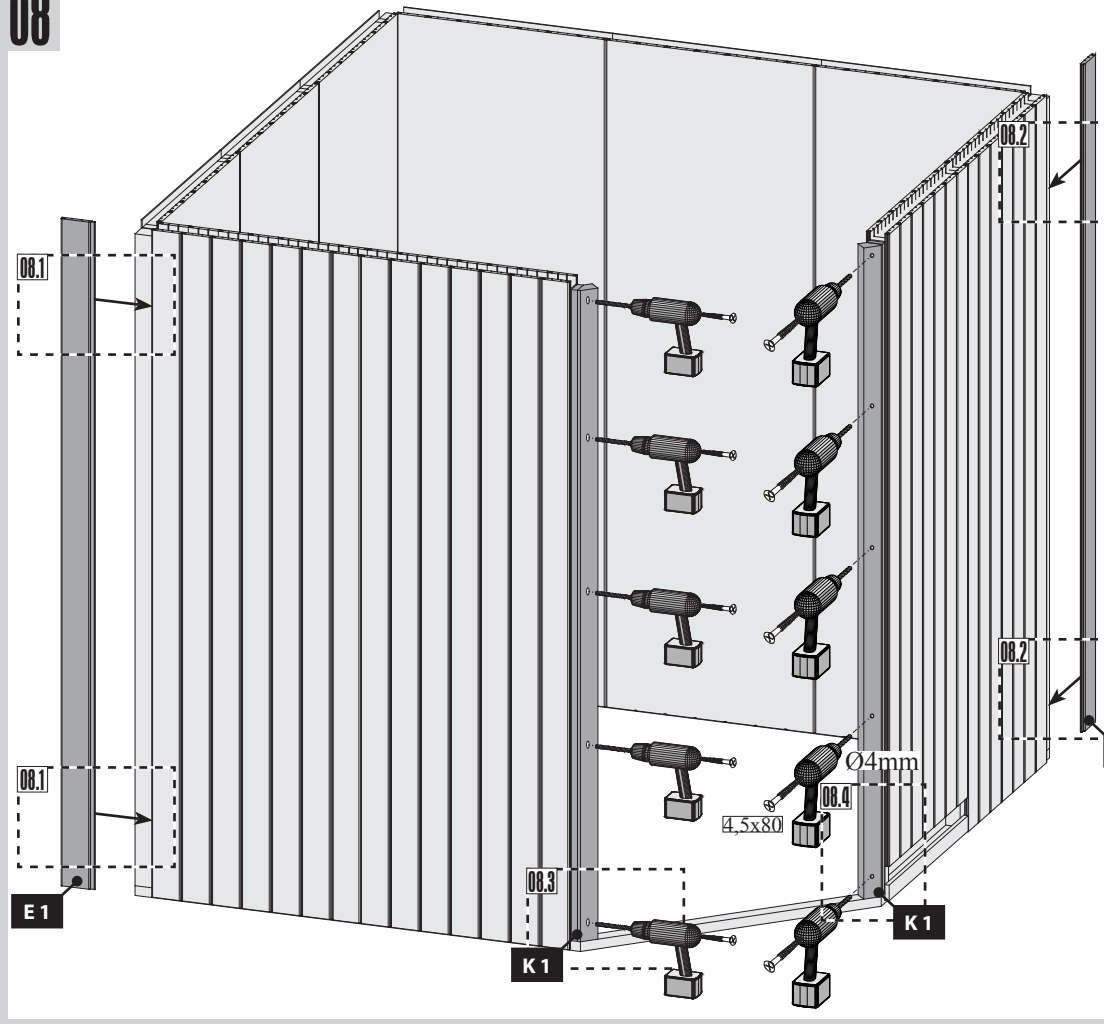

 Einbau Saunatür

 Sauna deur installatie

 Sauna Instalace dveře

 Installation de porte Sauna

 Instalación de la puerta Sauna

 Sauna door installation

 Installazione porta Sauna



!!! 01 → 03 !!!

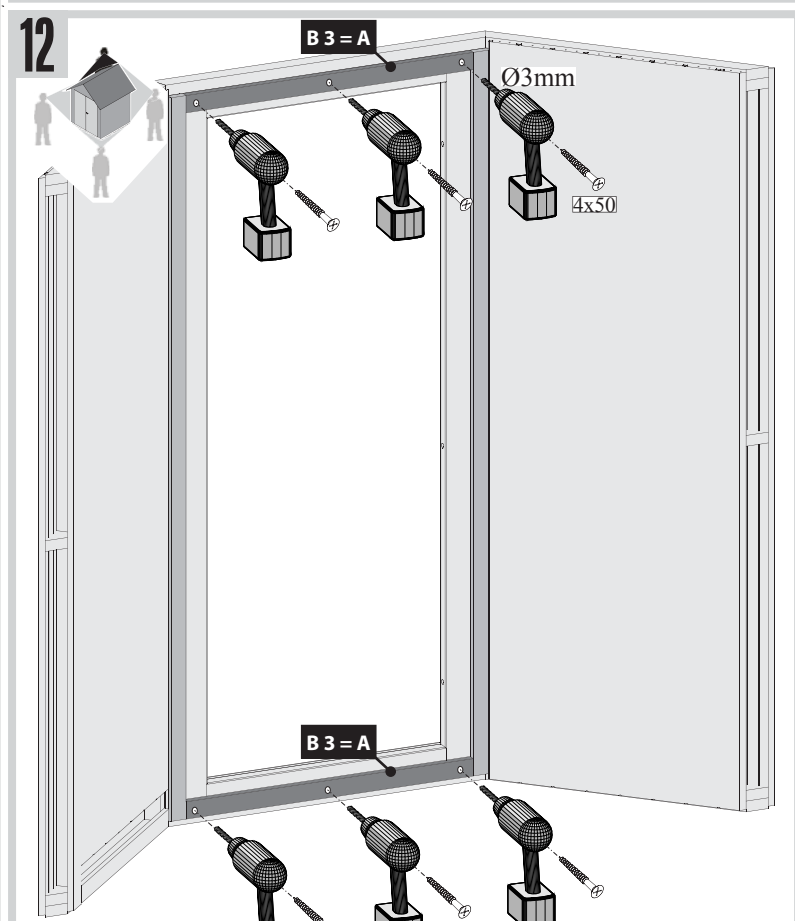
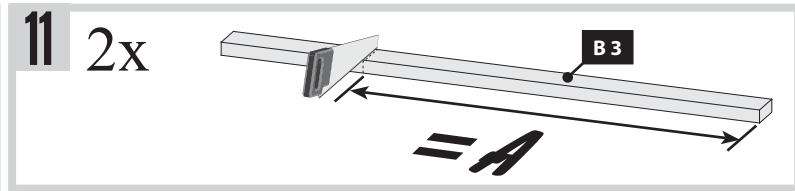
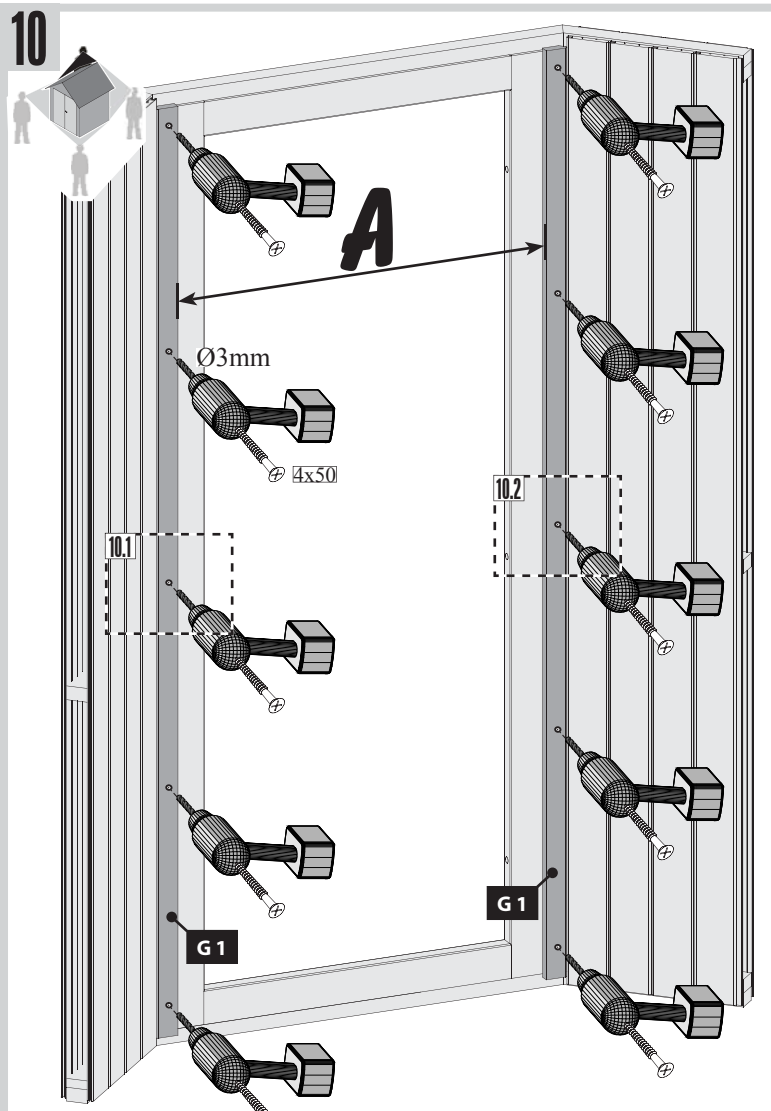
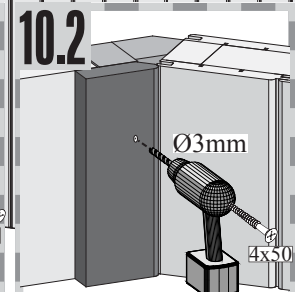
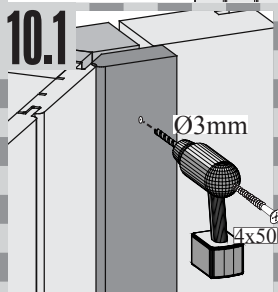
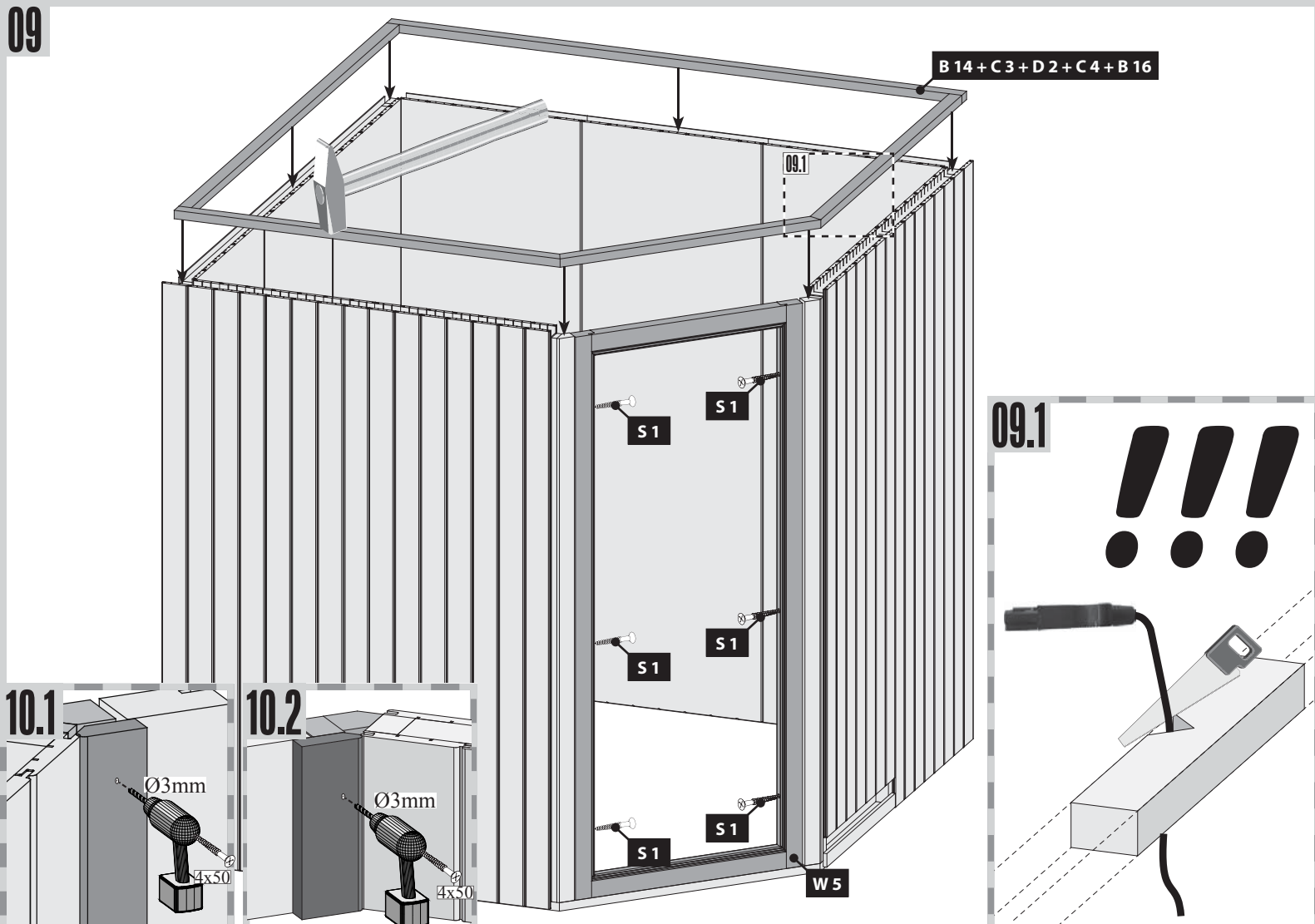

13

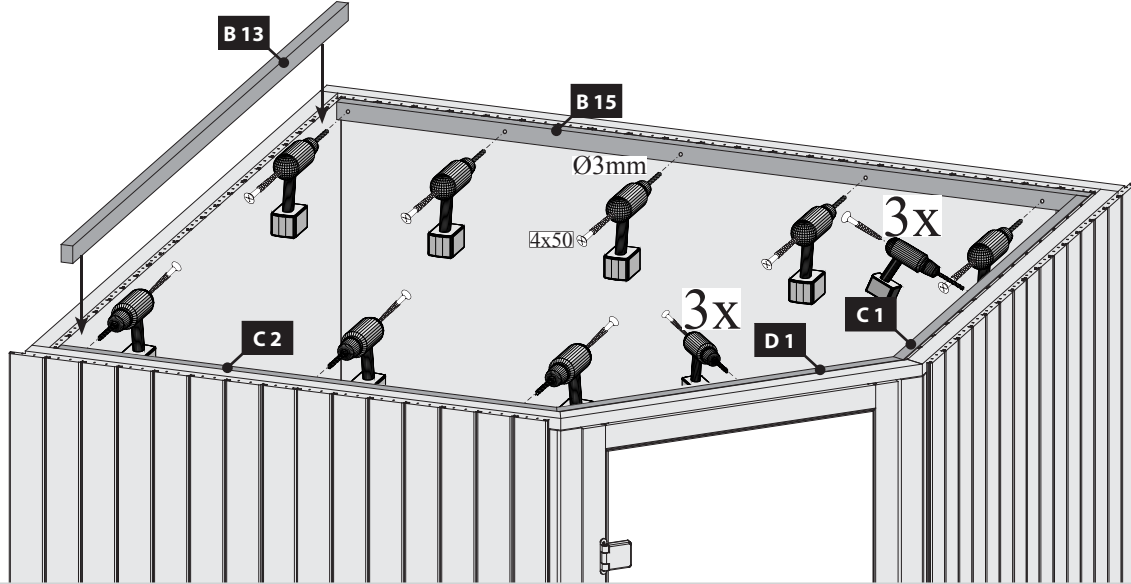
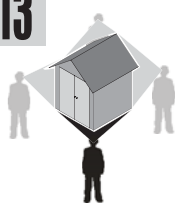

14

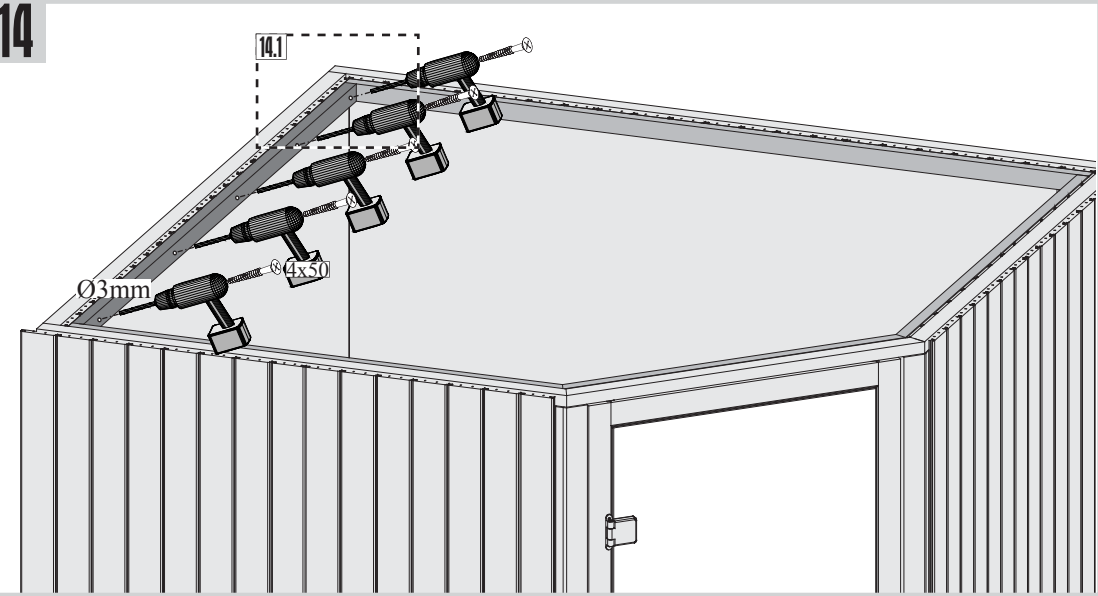

14.1

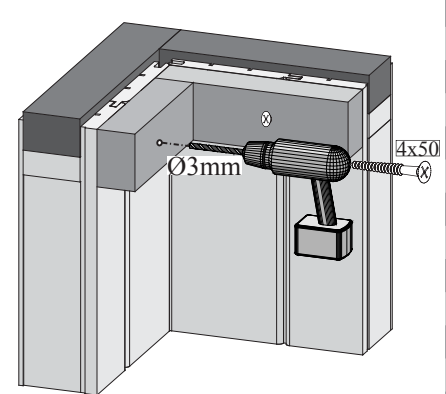

15

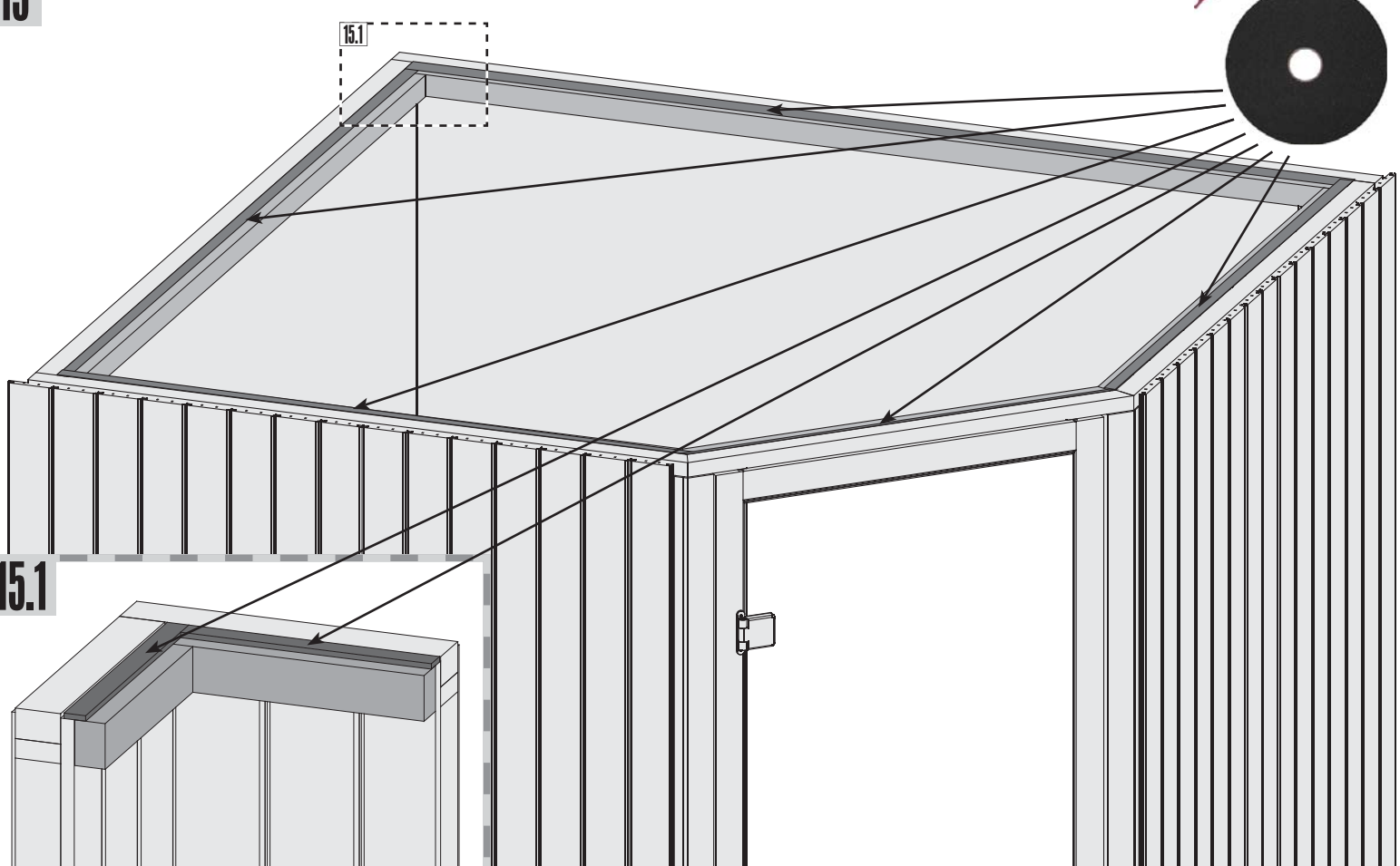

15.1

16

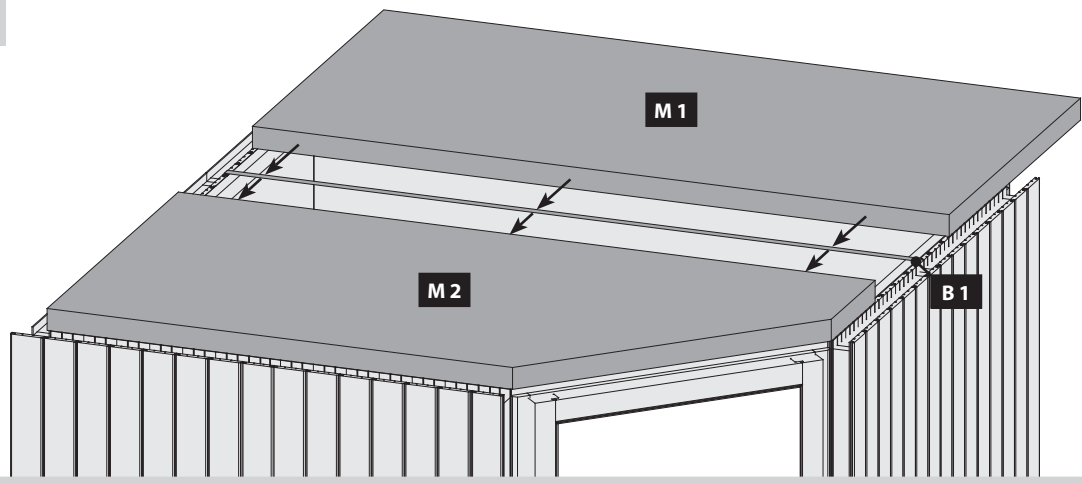

17

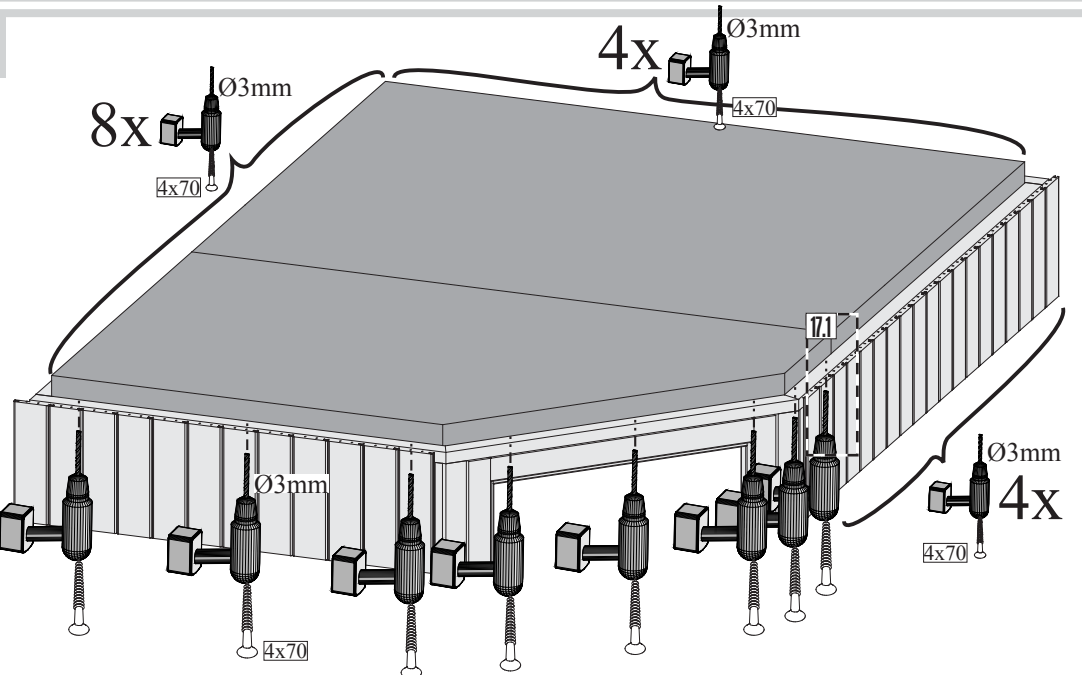

18

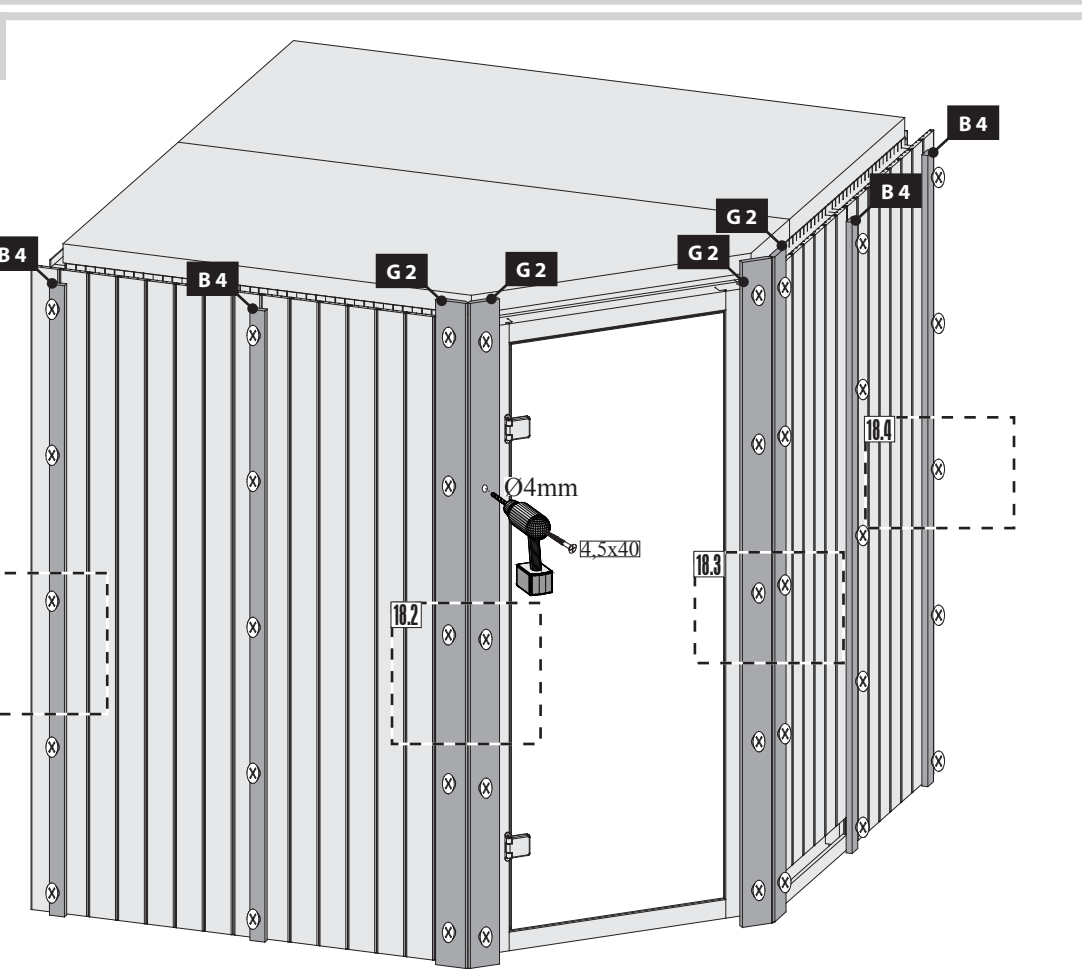

17.1

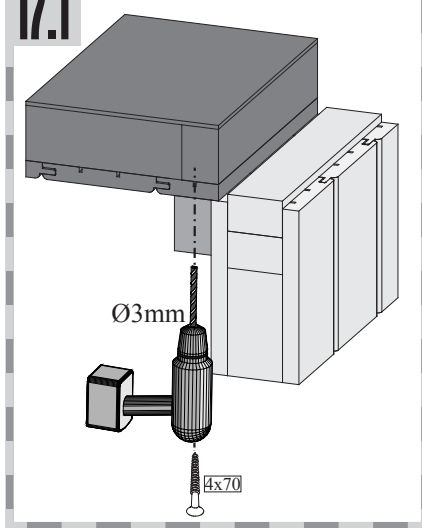

18.1

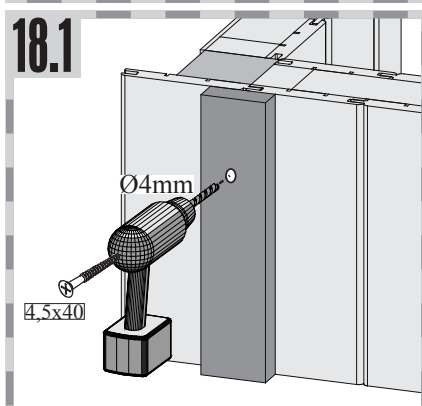

18.2

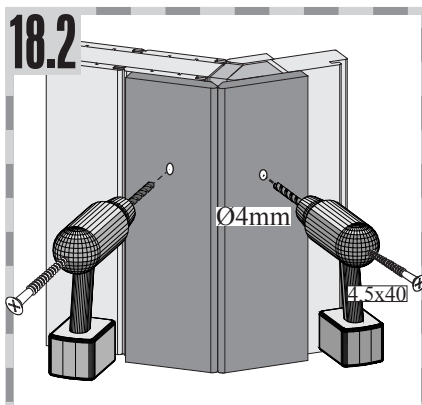

18.3

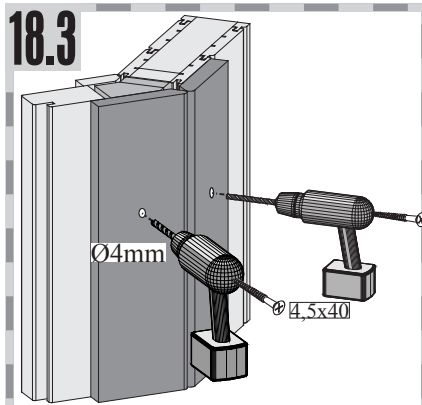

18.4

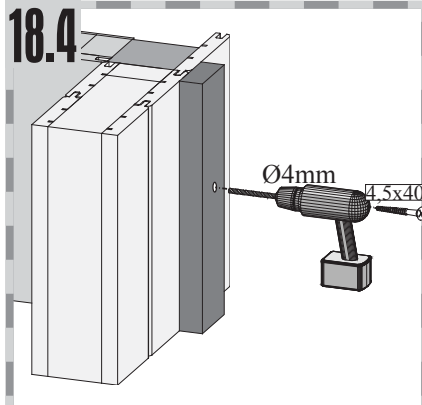

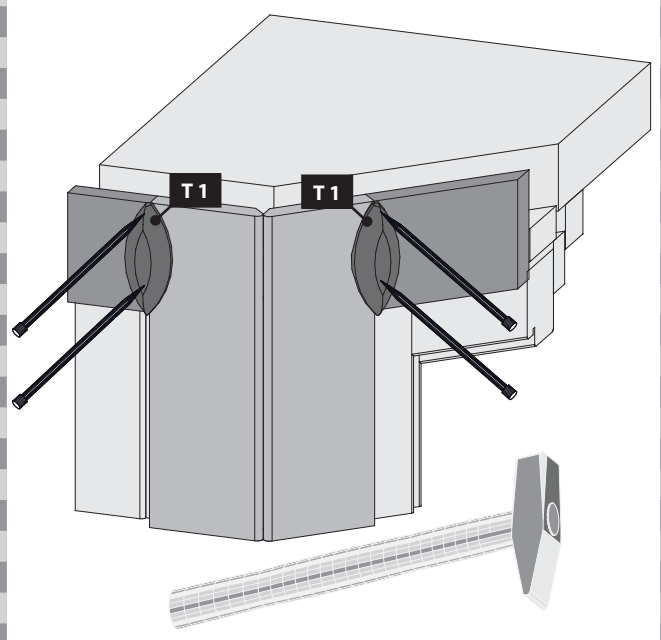
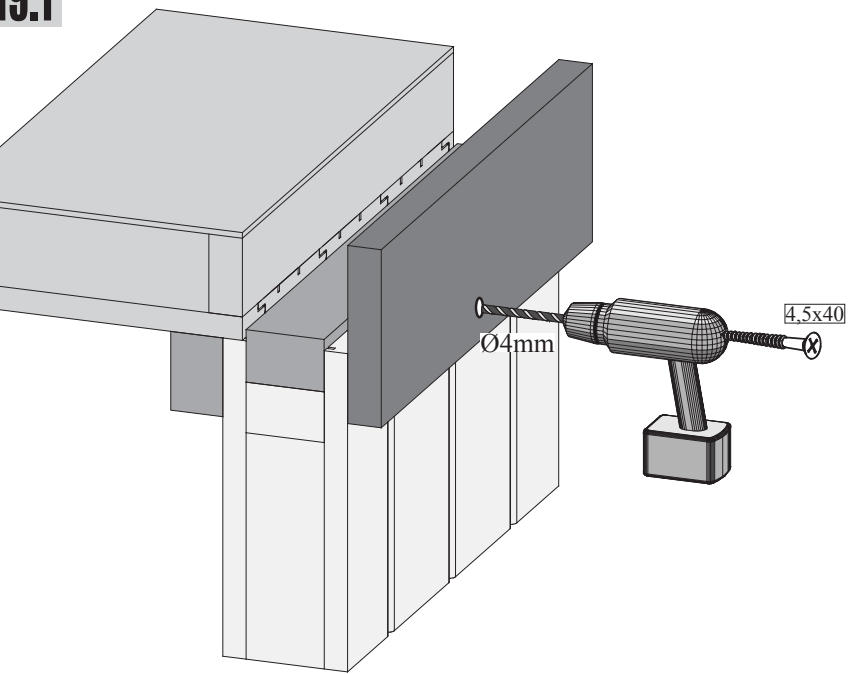
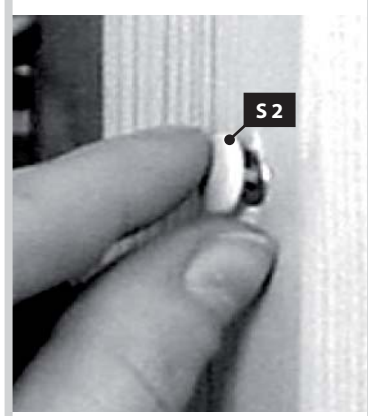
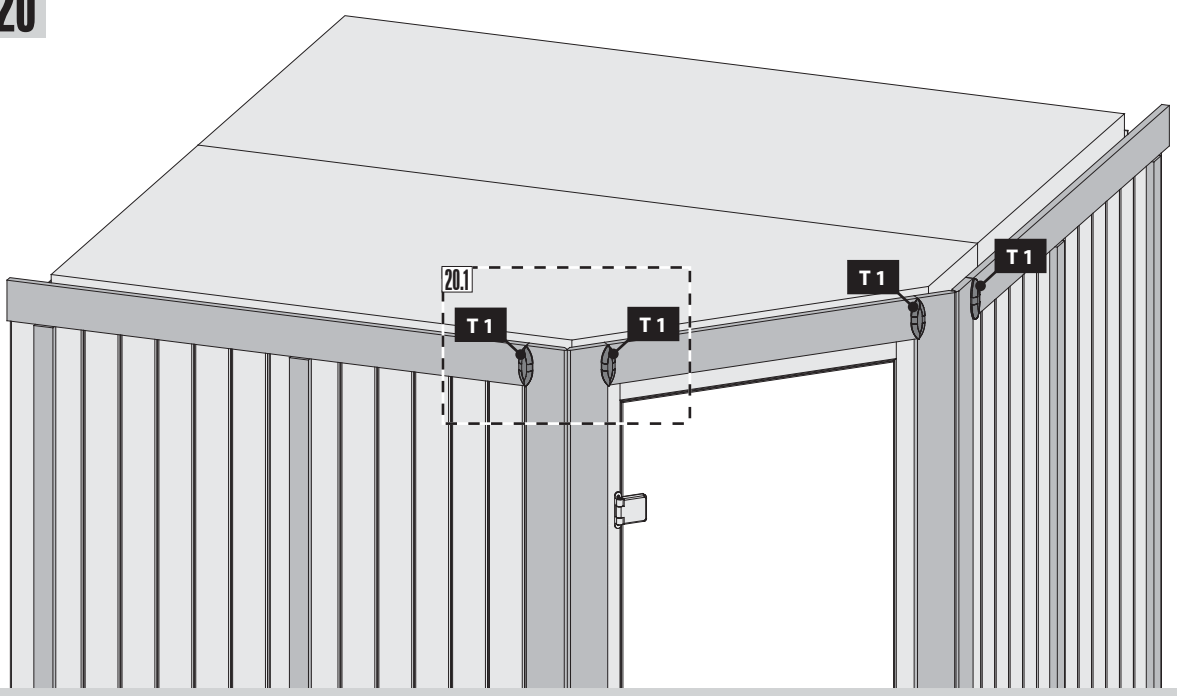
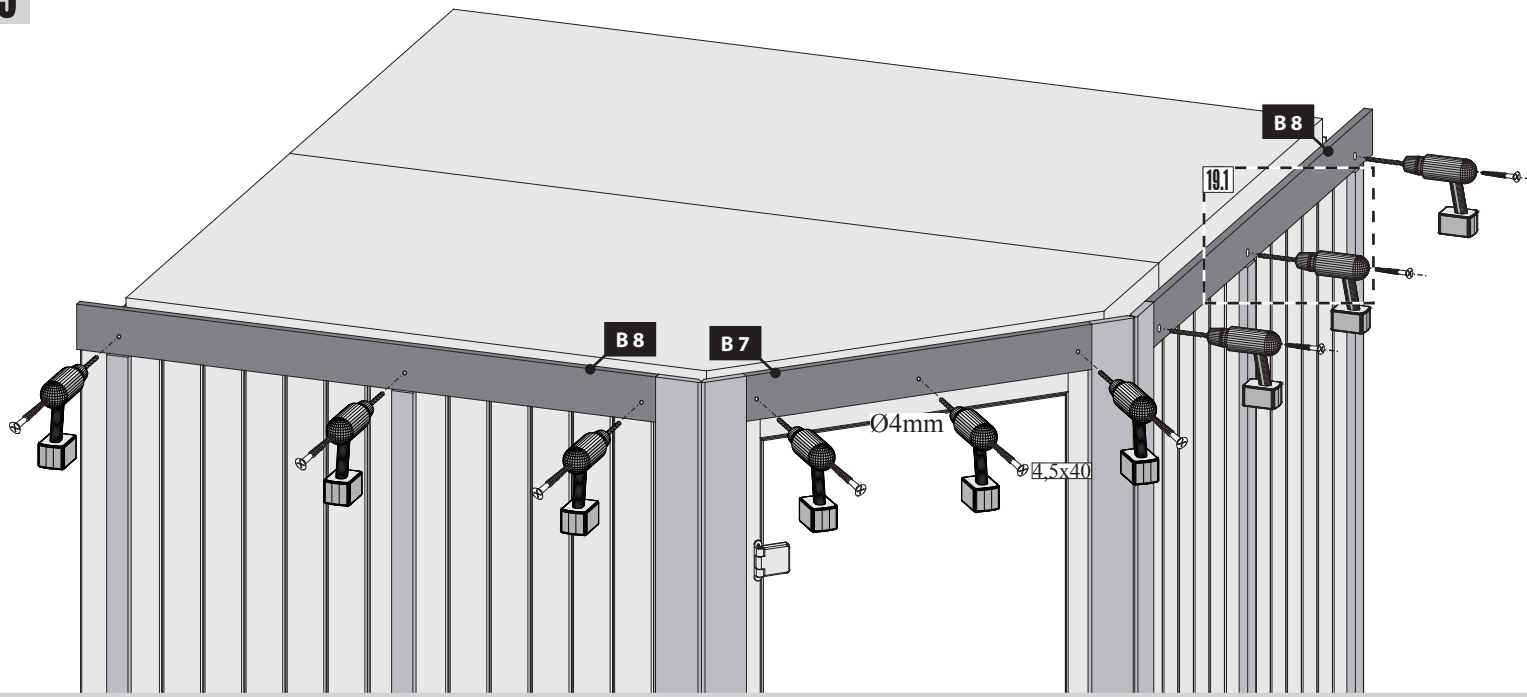

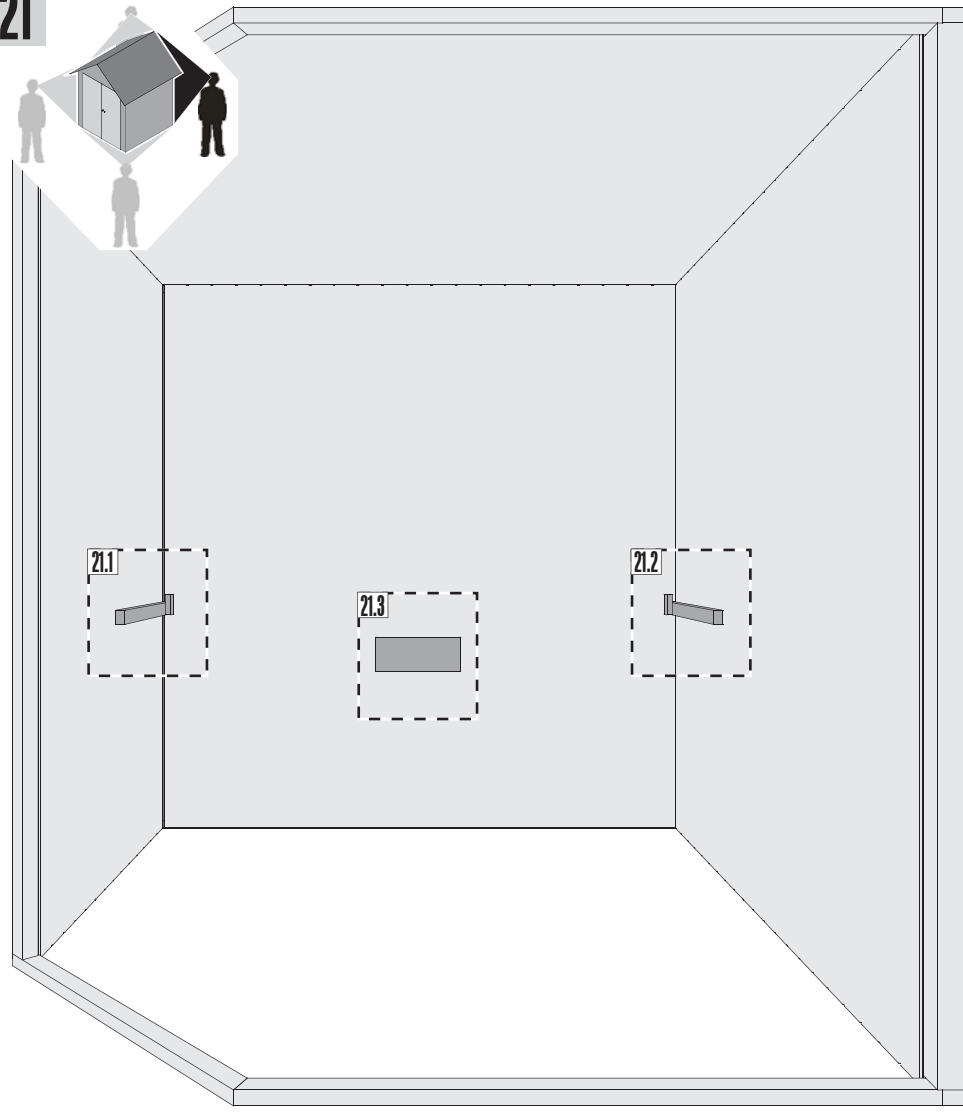

21.1-1

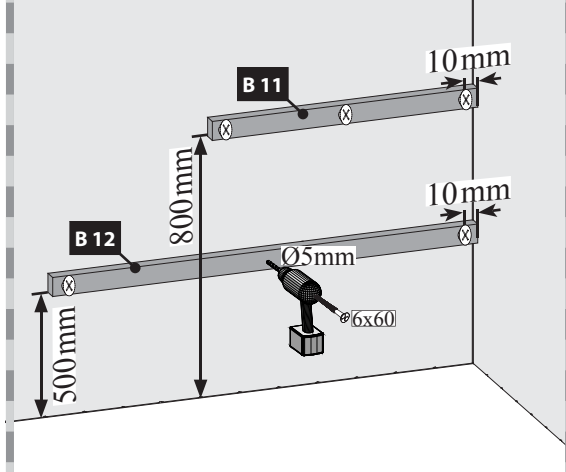

21.1-2

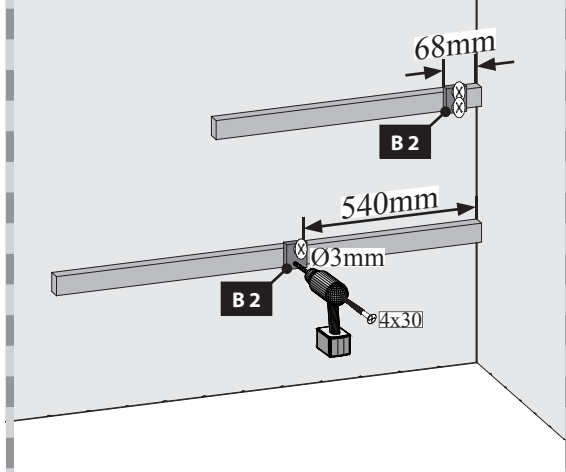

21.2-1

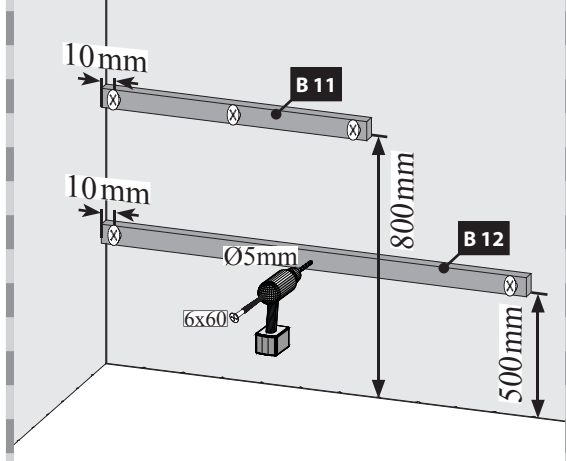

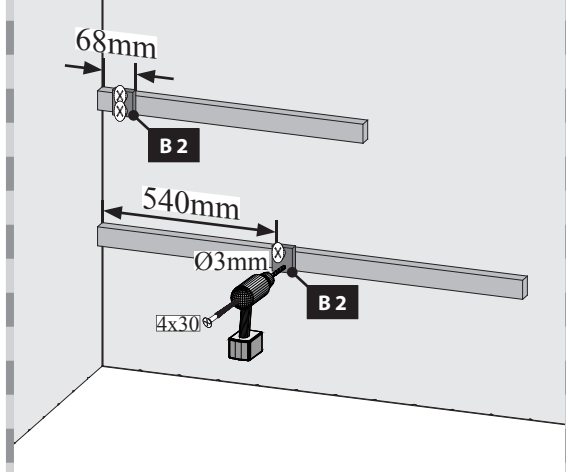

21.2-2



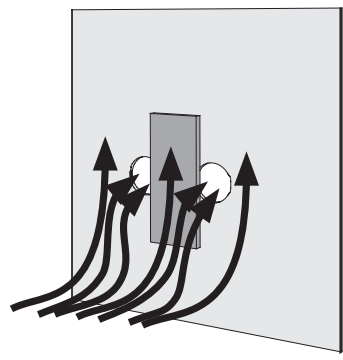
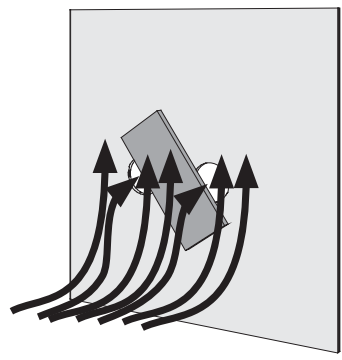
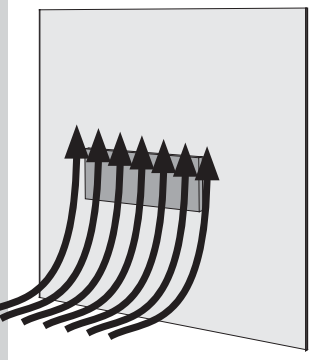
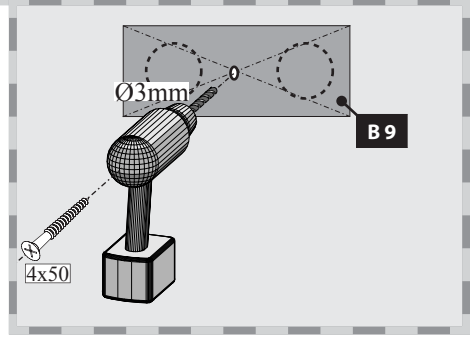

21.3





 Hier ist die Funktionsweise des Brettes abgebildet. Regeln Sie damit die Abluft nach Ihren eigenen Wünschen.

 Ceci représente le mode de fonctionnement de la planche. Avec elle, réglez l'écoulement de l'air selon vos désirs.

 This figure shows the functional principle of the board. Regulate the exhaust air according to your own wishes.

 Hier is de werking van het plankje afgebeeld. Regel daarmee de luchtafvoer naar eigen wens.

 Aquí está representada la forma de funcionamiento de la tabla. Regule con ello el aire de salida según sus propios deseos.

 Viene illustrato il principio di funzionamento della tavoletta di regolazione della ventilazione. Con essa si può regolare a piacere la ventilazione.

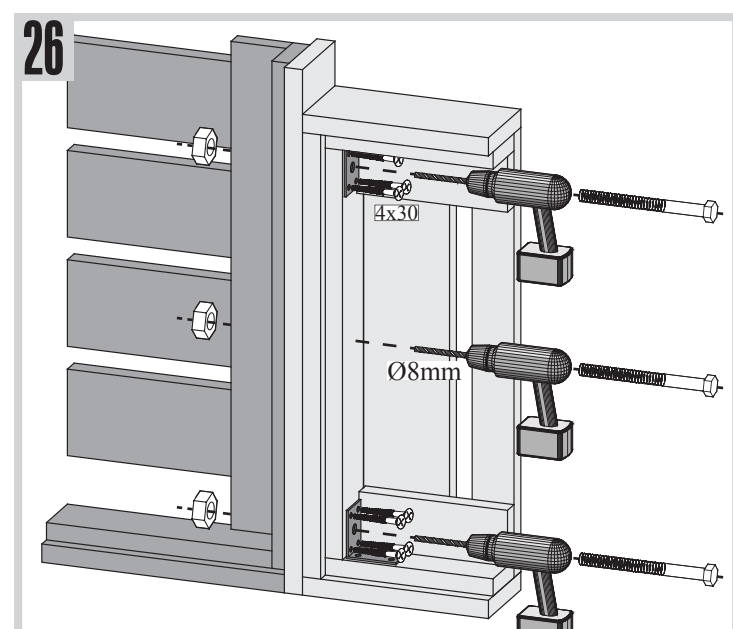
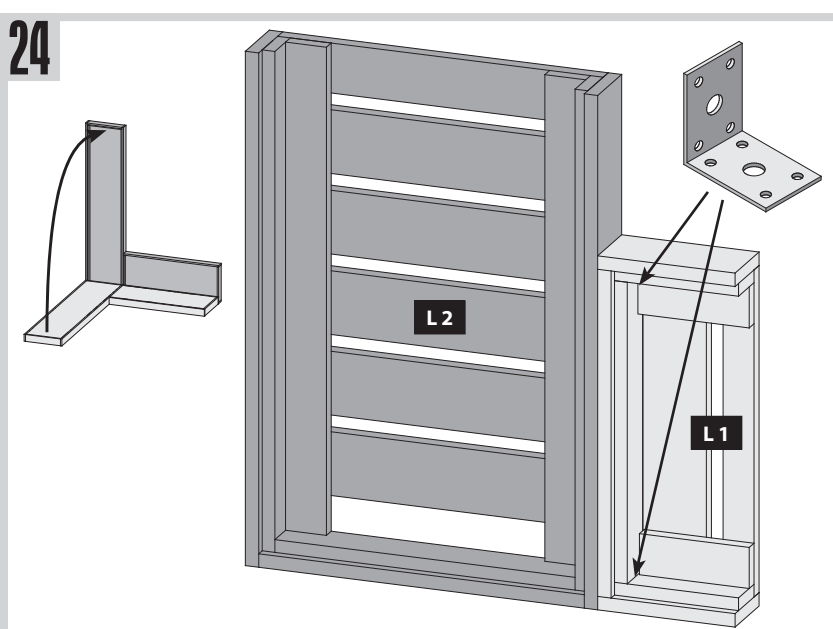
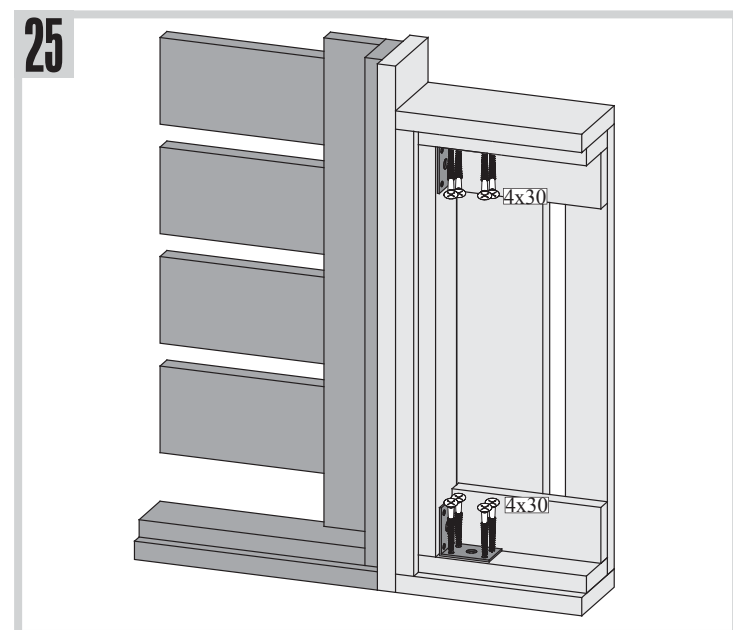
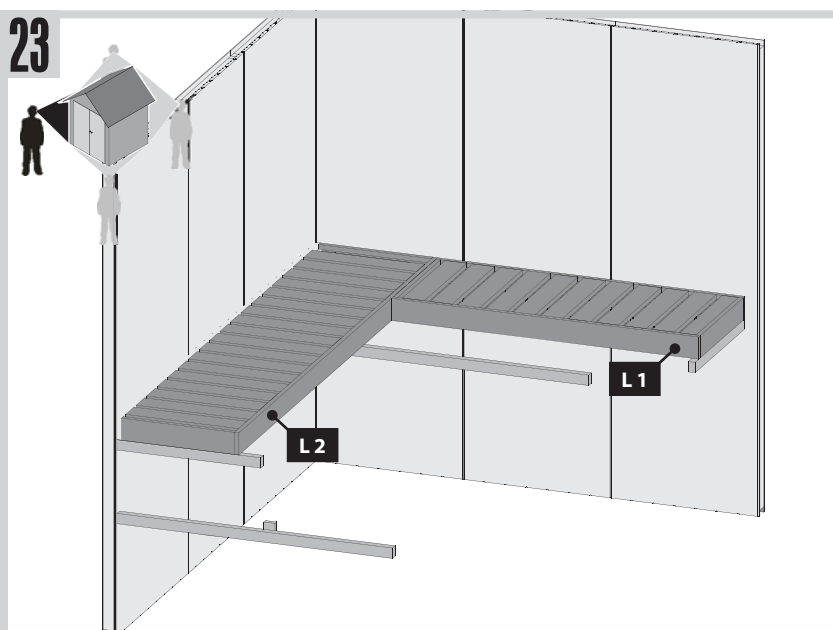
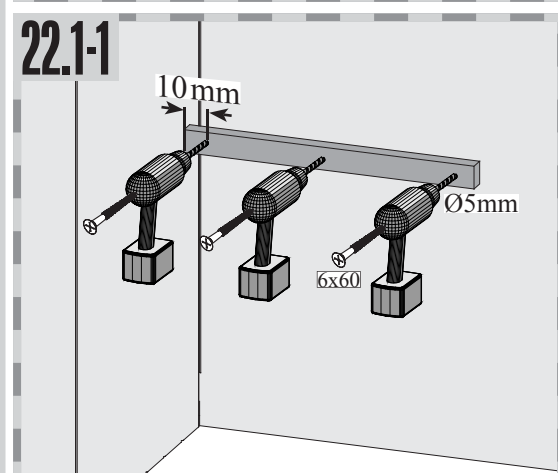
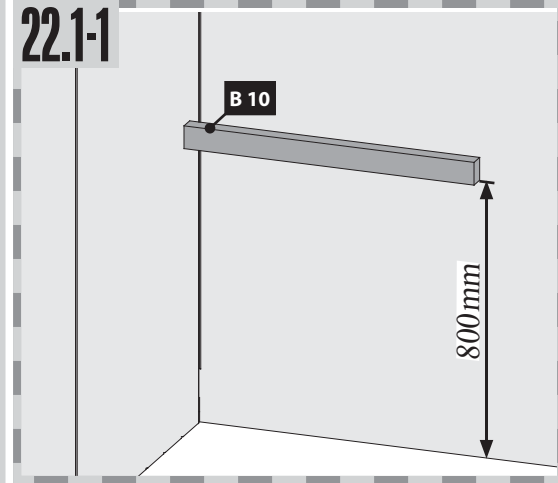
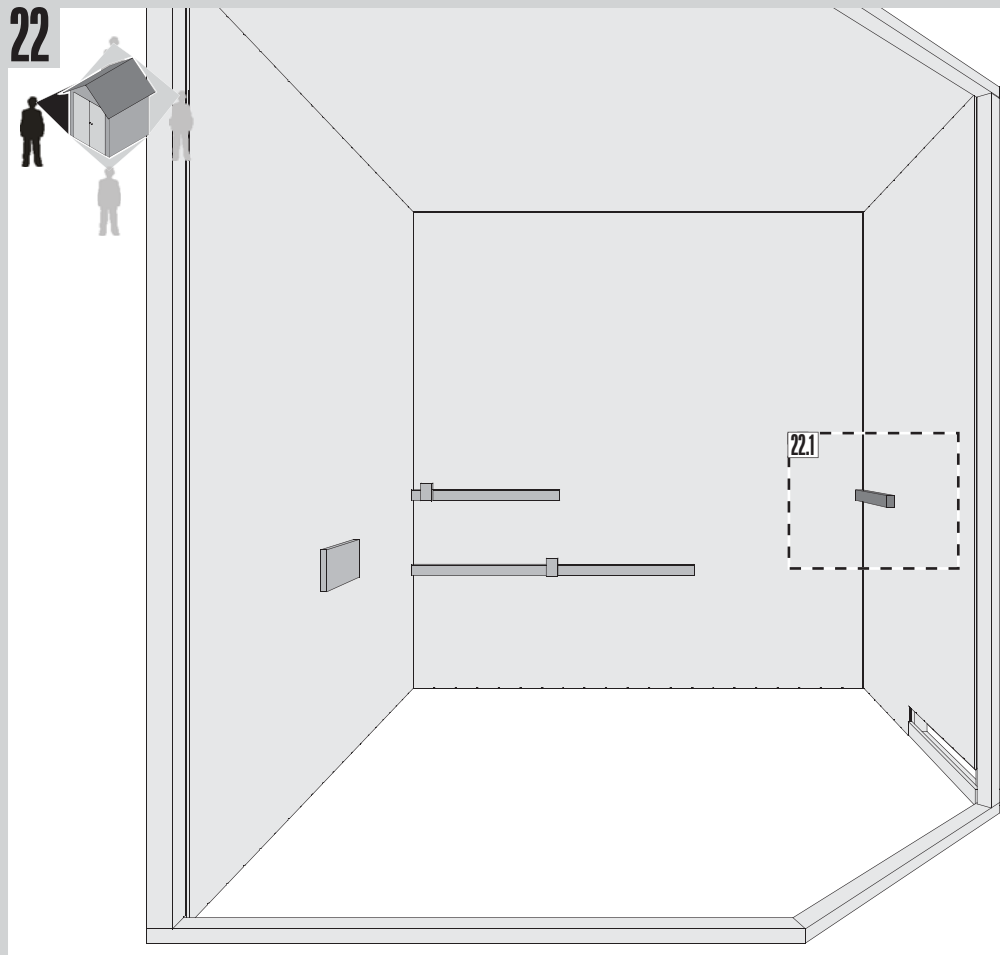

27

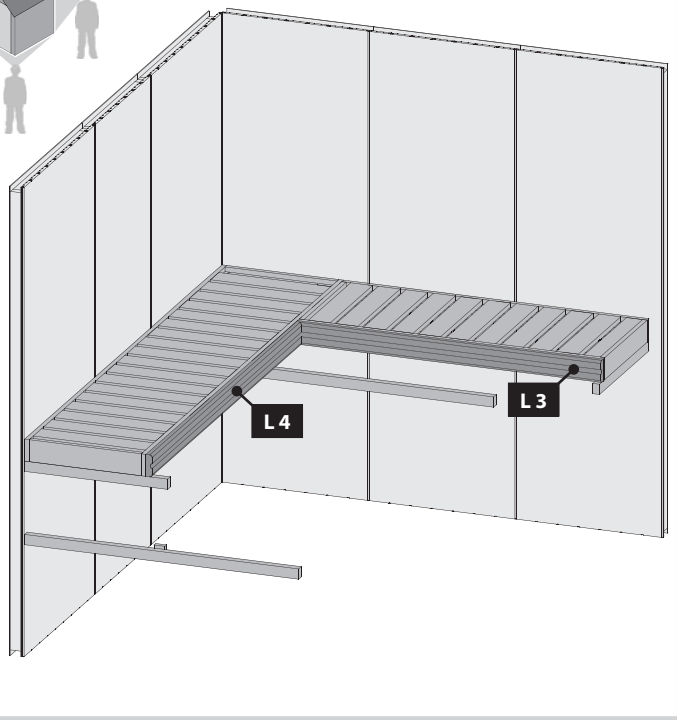
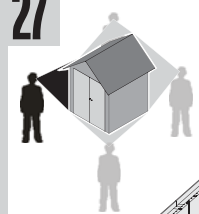

28

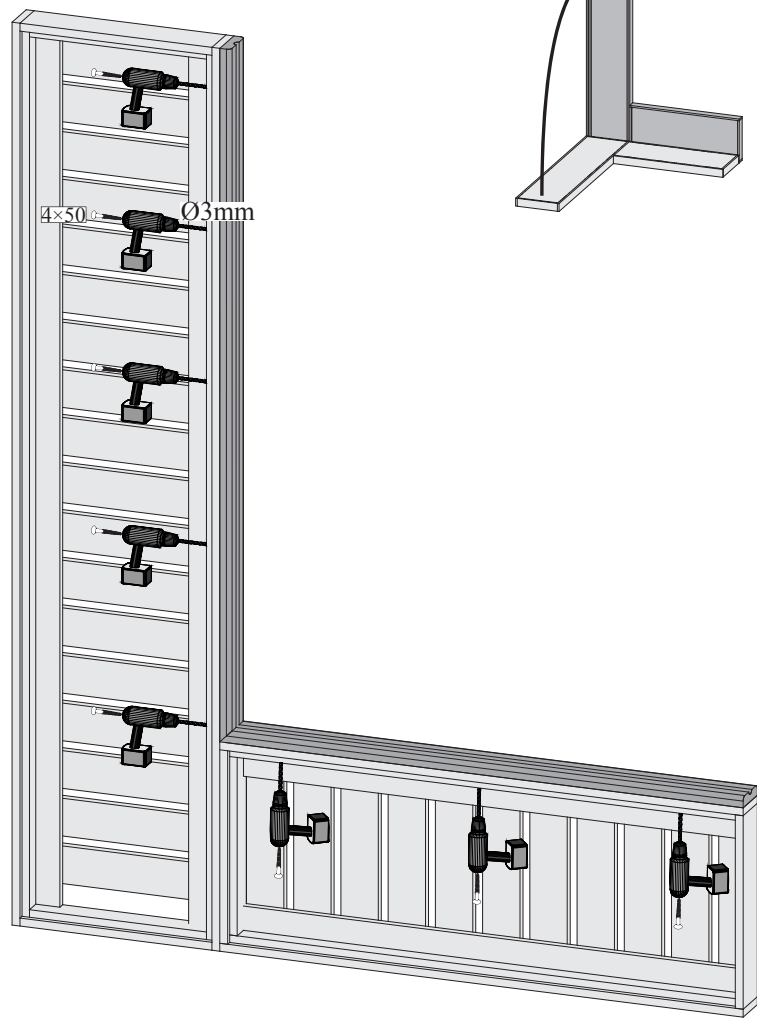

29

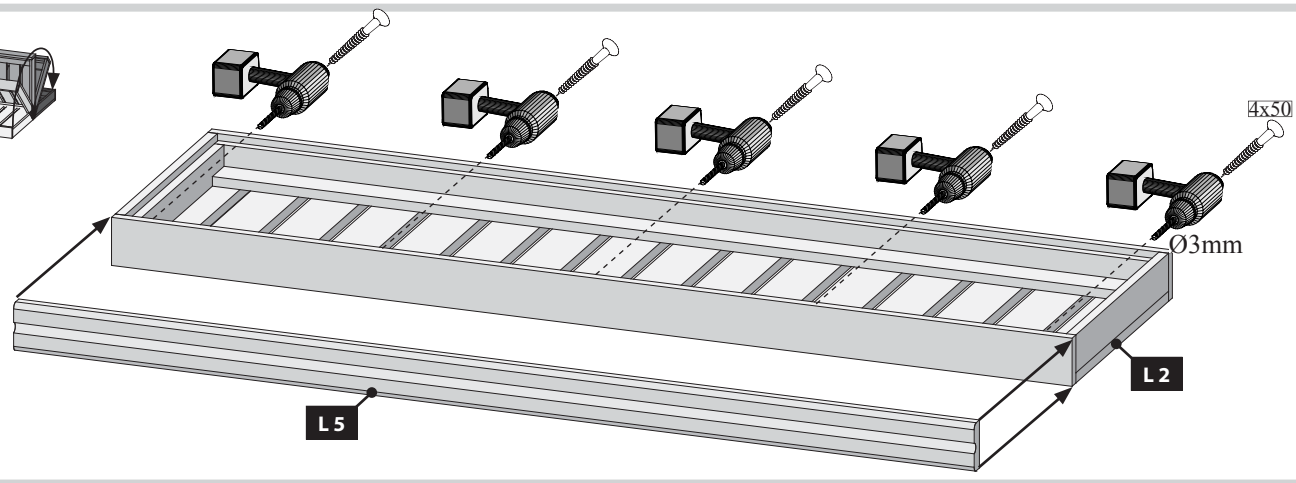
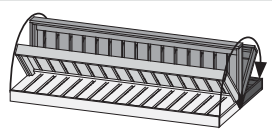

30

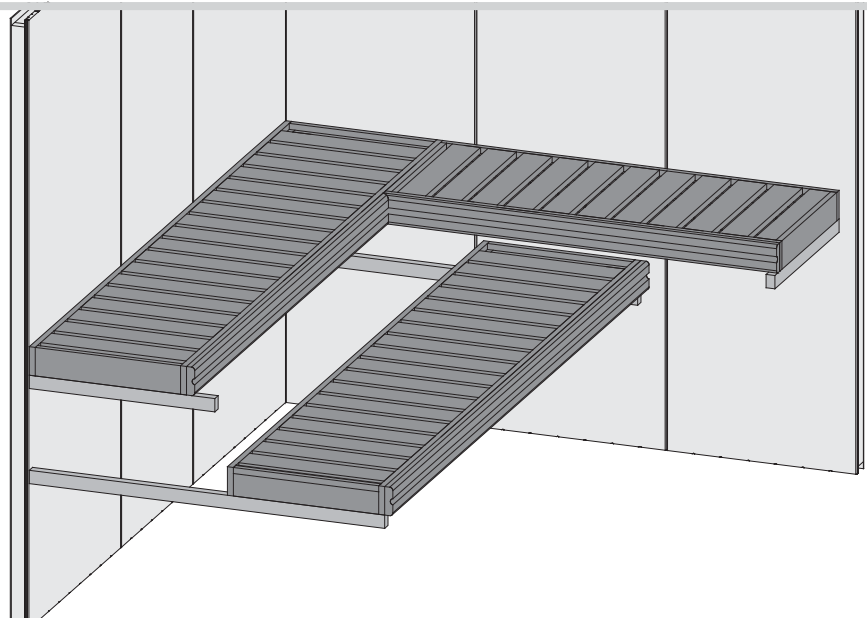

31 2x

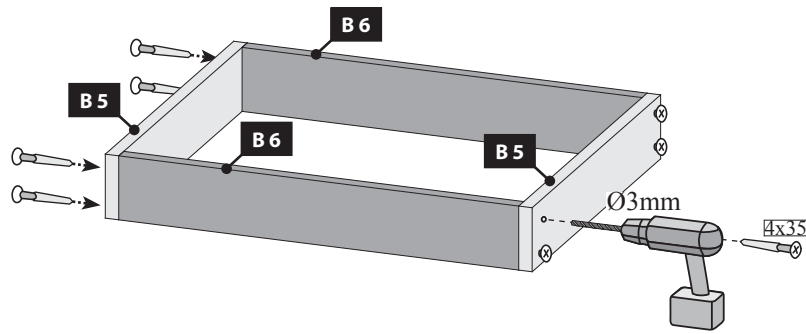

32 a

-  Nur bei 9 kW-Ofen
-  Seulement 9 kW chauffe
-  Only 9 kW heater
-  Slechts 9 kW heater
-  Sólo calentador de 9 kW
-  Solo riscaldamento 9 kW
-  Pouze topné těleso 9 kW

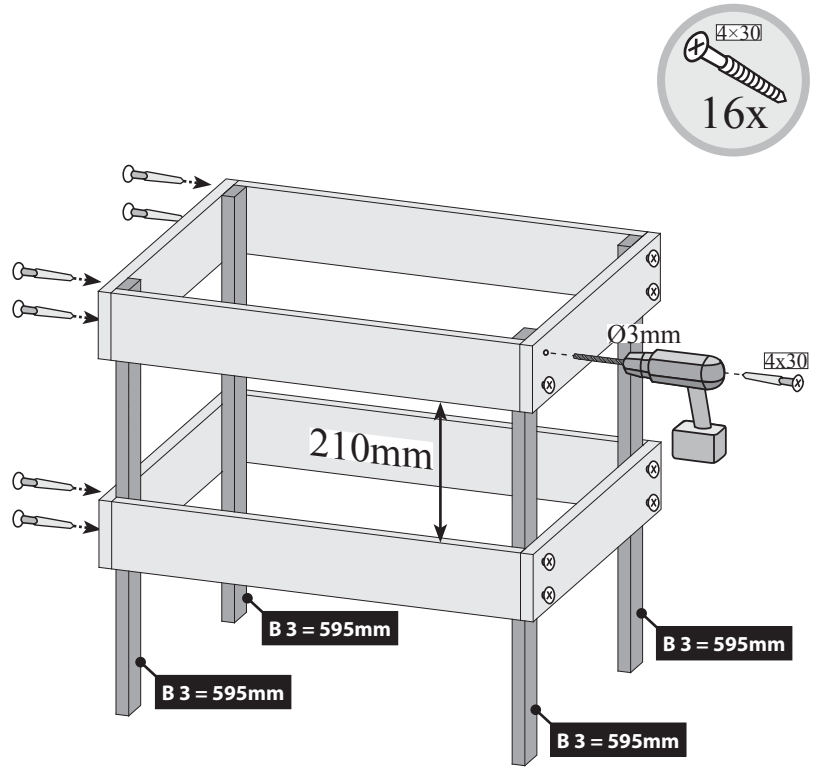
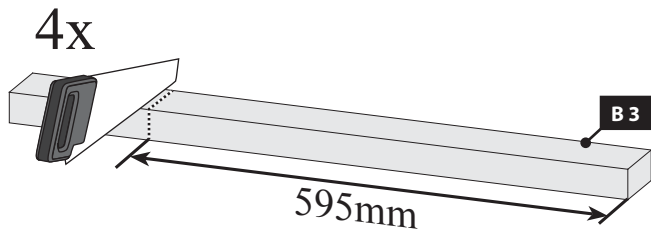

32 b

-  Bei allen anderen Öfen
-  Pour tous les autres fours
-  For all other furnaces
-  Voor alle andere ovens
-  Para todos los otros hornos
-  Per tutti gli altri tipi di forni
-  U všech ostatních pecích

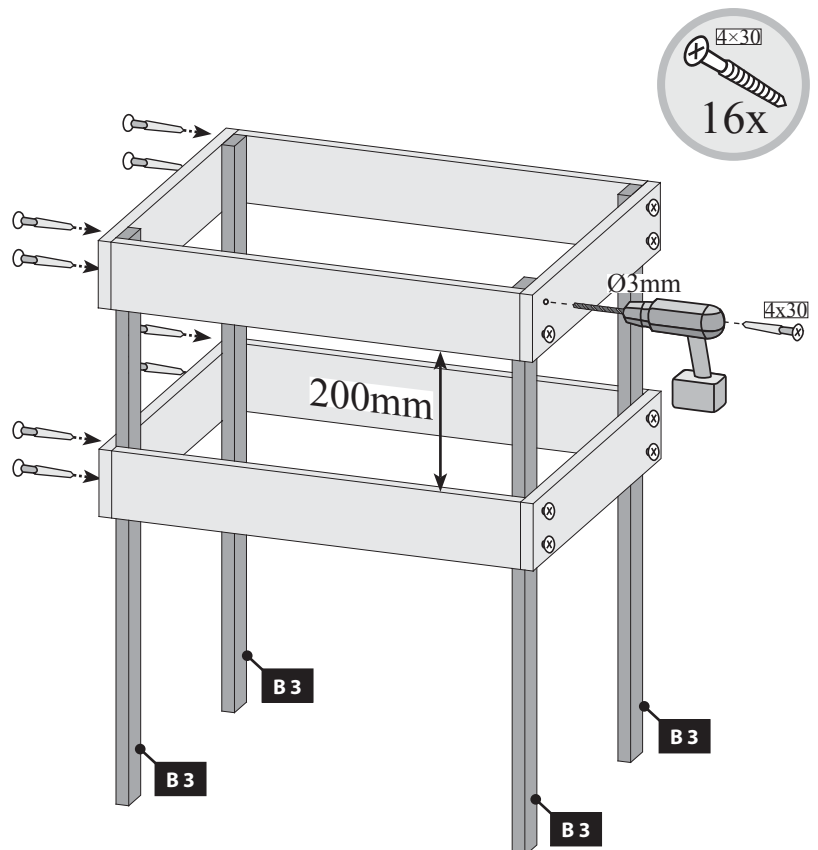

33

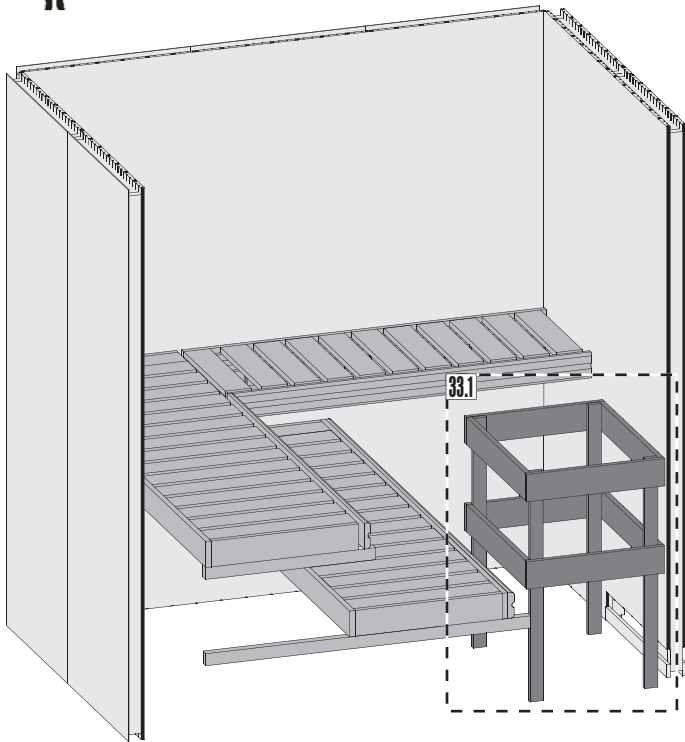
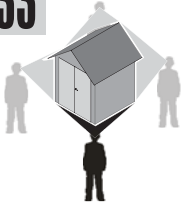



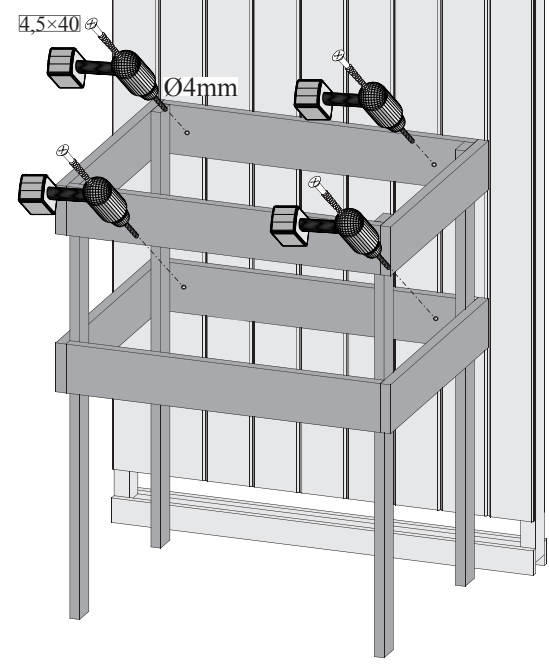
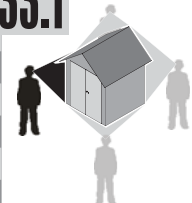

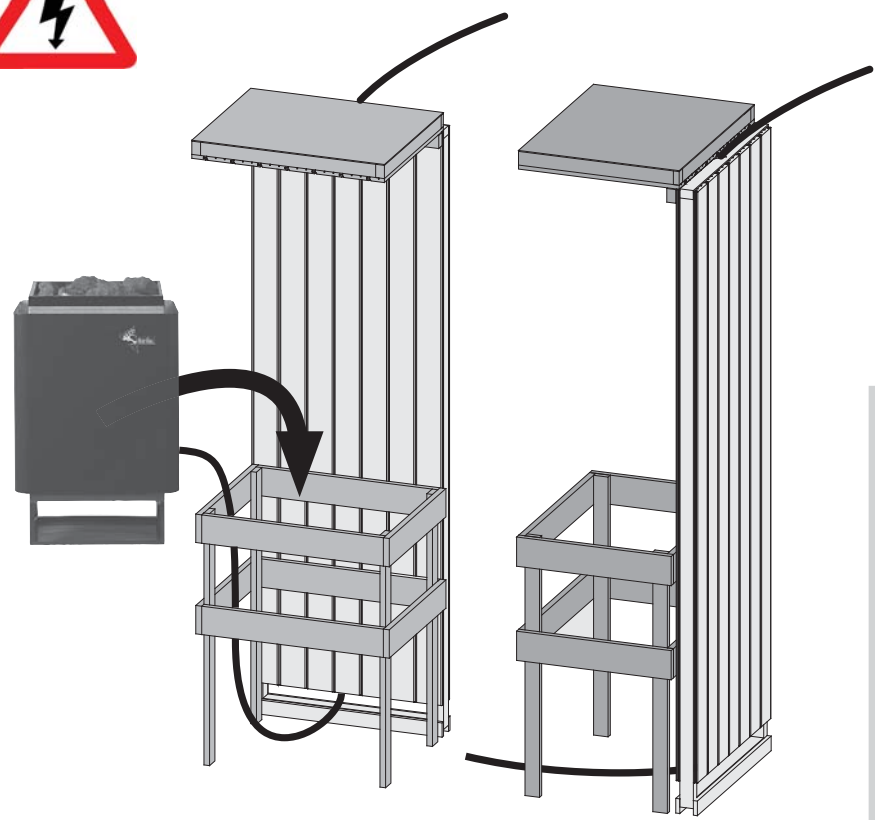

33.1



34



STOP

-  Einbau Saunatür
-  Installation de porte Sauna
-  Sauna door installation
-  Sauna deur installatie
-  Instalación de la puerta Sauna
-  Installazione porta Sauna
-  Sauna Instalace dveře

!!! 06 → ... **!!!**