

**2520W0**



**2520W1**

**Wir danken für den Kauf von Produkten unserer Firma.**

Die Anschaffung der Erzeugnisse aus unserem Betrieb in Borzechowo war eine richtige Wahl. Wir gratulieren und bedanken uns für das uns erwiesene Vertrauen. Produkte mit dem Logo von MEGIW werden nach neusten Technologien verbunden mit Tradition hergestellt. Die Anwendung von qualitativ hochwertigen Stoffen erlaubt eine langjährige, zuverlässige Nutzung.

Dieses Dokument enthält:

- Garantiebedingungen,
- Montageanleitung für das Produkt.

**Garantiebedingungen:**

Der Garant sichert dem Käufer eine hohe Qualität der Produkte zu, unter der Bedingung, dass sie richtig nach dieser Anleitung montiert und genutzt werden und die nachstehend beschriebenen Nutzungsregeln eingehalten werden.

**1. Eine sehr wichtige Frage bei der Montage des Produktes ist eine gute Vorbereitung des Grundes - durch Nivellieren . Bei falscher Nivellierung des Grundes können folgende Folgen auftreten:**

- falsch schließende Türen,
- Lichtspalte zwischen den Brettern,
- Verkrümmung des Fensters oder der Tür.

**2. Da es die von uns verkauften Produkte meistens in roher / natürlicher Form gibt, wird durch den Hersteller empfohlen, die Produkte mit allgemein nutzbaren dafür vorgesehenen Mitteln zu imprägnieren.**

3. Ansprüche des Kunden aus der Garantie werden ausschließlich auf der Grundlage der Originalrechnung mit Kaufdatum sowie der Originaletikette des Produktes mit deutlichem Herstellungsdatum anerkannt. Es werden Reklamationen bearbeitet, wo der Mangel direkt zum Zeitpunkt der Entstehung gemeldet wird.

4. Darüber, ob die Reklamation zur Bearbeitung angenommen wird oder für unbegründet gehalten wird, informiert der Hersteller oder der Verkäufer den Kunden in einer Frist von:

- vierzehn Tagen nach dem Eingang der Reklamationsmeldung,
- bei Feststellung einer unbegründeter Reklamation kommt der Kunde für sie auf,
- wenn ein Mangel, der Gegenstand der Reklamationsmeldung darstellt, behebbbar ist, wird die Garantieleistung durch Garantiereparatur realisiert.
- Termin der Behebung des Reklamationsmangels beträgt 21 Tage nach dem Eingang der Meldung.

### Die Garantie des Herstellers umfasst keine:

- Beschädigungen, die aus Zufallsereignissen oder anderen Umständen resultieren, die der Hersteller nicht zu vertreten hat.
- Beschädigungen, die bei den durch den Kunden mit Hilfe von Werkzeugen und Elementen, die durch den Hersteller nicht genannt werden, selbstvorgenommenen Änderungen entstanden sind.
- Beschädigungen, die wegen der Nichtbeachtung der durch den Hersteller empfohlenen Regeln für die Nutzung, Konservierung und Lagerung entstanden sind.
- Mängel und Beschädigungen (die dem Käufer bei der Abnahme des Produktes bekannt waren), aufgrund deren der Preis reduziert wurde.
- durch den Hersteller im Prototyp vorgesehenen Unterschiede in Profilen, Farbtönen, die aus den entworfenen dekorativen und ästhetischen Merkmalen des Erzeugnisses sowie aus den für die Stoffe, aus den die Gartenhäuser hergestellt wurden, typischen Merkmalen, resultieren.
- Beschädigungen, welche durch natürlichen Verschleiß entstehen.
- Hersteller behält sich auch das Recht vor, die Forschung und technische Änderungen der Ware. Daher kann leichte Mehrdeutigkeit bei der Beschreibung in der Anweisung vorkommen. Solche Fehler sind kein Reklamationsgrund.

Im Falle von Problemen, wenden Sie sich bitte direkt an uns oder Anbieter. Wir werden Ihnen Gerne zur Verfügung stehen und behilflich sein.

Darüber hinaus werden keine gesunden Astansätze sowie natürlichen Mikrorisse des Holzes für Mängel gehalten, die während der Nutzung des Holzes entstehen, durch wechselbare Wetterverhältnissen, bei denen der Produkt genutzt wird, hervorgerufen werden, und die aus natürlichen physikalischen Eigenschaften des Holzes resultieren.

Die entstandenen Risse haben keinen Einfluss auf die Nutzungseigenschaften sowie Lebensdauer des Produktes.

Detailliert Informationen finden Sie auf der Internetseite des Herstellers - [www.megiw.pl](http://www.megiw.pl)

### Vorbereitung des Wandelementes zur Montage der Multifunktions – Steuerung

Zur Montage der Bedieneinheit muss die Öffnungshöhe im Wandelement 10 cm betragen. Dazu schieben Sie das bewegliche Profilbrett und die Kunststoffrohre nach oben heraus und kürzen Brett und Rohre entsprechend.

**ACHTUNG: Dies ist unbedingt VOR dem Aufstellen des Wandelementes durchzuführen!**

R1-R5: Diese dienen als Montagerohre für die Elektrokabel der Netzzuleitung, der Saunalampe und des Saunaofens, ausgehend vom Steuergerät.

**R1 + R4:** für Leitung vom Modul Ofensteuerung zum Saunaofen

**R2 :** für Leitung vom Modul Ofensteuerung zur Bedieneinheit

**R3 :** Reserve  
**R5 :** Reserve

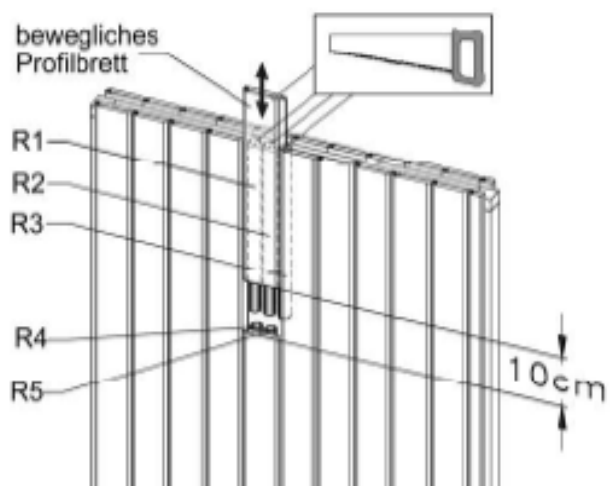

## Werkzeug

Folgendes Werkzeug sollten Sie vor Beginn der Montage zurecht gelegt haben.

Wasserwaage

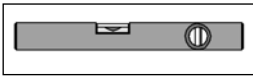

Rollmaß

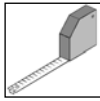

Bohrmaschine

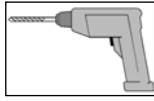

Elektroschrauber

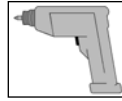

Hammer



Schraubendreher

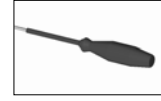

Feinsäge / Handkreissäge

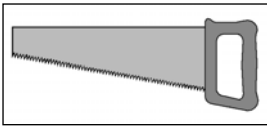

Universalmesser

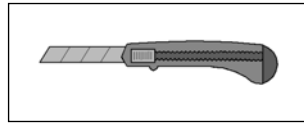

Schraubenschlüssel

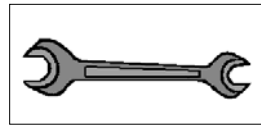

Inbusschlüssel

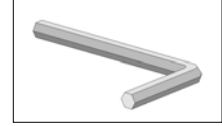

## Abkürzungen / Symbole:

Abb. - Abbildung  
cm - Zentimeter  
mm - Millimeter  
ca. - circa



- Zuluftöffnung



- Abluftöffnung



Aufbauvarianten

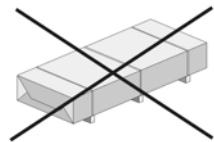

Nicht im Lieferumfang enthalten!

**You have made the right choice purchasing products from our company in Borzechowo.**

We congratulate and thank you for putting your trust in us. Products with the MEGIW logo are made in accordance with the newest technology combined with tradition. The use of high-quality materials allows for many years of reliable operation.

This document contains:

- conditions of guarantee,
- product assembly instructions.

**Conditions of guarantee:**

The guarantor shall provide the purchaser high-quality products, provided the product has been properly assembled and used in accordance with the following instructions and the terms of use described below are respected.

**1. An extremely important issue in the assembly of this product is correct surface preparation. This is done by levelling the surface.**

**In the event of improper levelling, the following could occur:**

- the doors not fully closing,
- the formation of spaces between boards,
- distortion of windows or doors.

**2. Given the fact that the products sold by us are frequently in the form of raw/natural materials, the manufacturer recommends impregnation using substances which are widely-available.**

3. Any customer claims under this guarantee will be considered only on the basis of the original bill of sale which shows date of purchase and the original product label which clearly shows date of production.

Complaints will be handled when the defect is reported as soon as it arises.

4. The customer will inform the purchaser on whether the complaint is accepted or if the complaint is deemed unjustified within the following time periods:

- fourteen days from the date the complaint was filed,
- in the case of unjustified complaints, the purchaser covers the costs,
- when the defect is removable, the guarantee will be carried out as repairs,
- the time period to remove the defect is 21 days from when the complaint was filed.

### The guarantee does not cover:

- Damage resulting from fortuitous events or other circumstances beyond the control of the manufacturer.
- Damage resulting from alterations made by the purchaser themselves using tools and other elements which are not indicated by the manufacturer.
- Damage caused by not complying with the rules recommended by the manufacturer regarding product use, maintenance and storage.
- Defects and damage, (which the customer was familiar with when they received the product) because of which the price was reduced.
- Intended differences made by the manufacturer in profiles and colour shades resulting from designed artistic and aesthetic characteristics of the product and features characteristic of raw materials from which furniture is made.
- Damage caused by natural wear and tear.

Furthermore - the following are not considered product defects: healthy knots and natural wood micro cracks, occurring during the process of using the wood, caused by changing atmospheric conditions, in which the product is used and which result from the natural physical properties of the wood.

The resulting cracks do not affect the usability and durability of the product.

More detailed information can be found on the manufacturer's website - [www.megiw.pl](http://www.megiw.pl)

### Preparing the wall panel for installation of the multi-function control system

For installation of the control unit, the opening height in the wall panel must be 10 cm.

To attain this height, push the loose sheathing board and the plastic pipes upward and out and shorten the board and pipes accordingly.

**NOTE: It is absolutely necessary that this be carried out BEFORE the wall panel is set up.**

R1-R5: These serve as assembly tubing for the mains connection electric cable, the sauna lamp and the sauna furnace ending at the control unit.

**R1 + R4:** for running cable from oven control system module to the sauna oven

**R2:** for running cable from oven control system modul to the control unit

**R3 + R5:** reserve

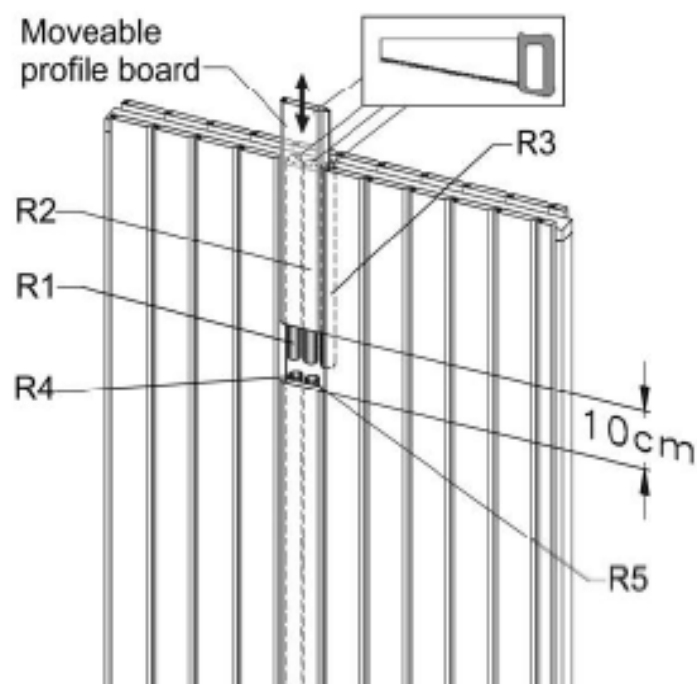

## Tools



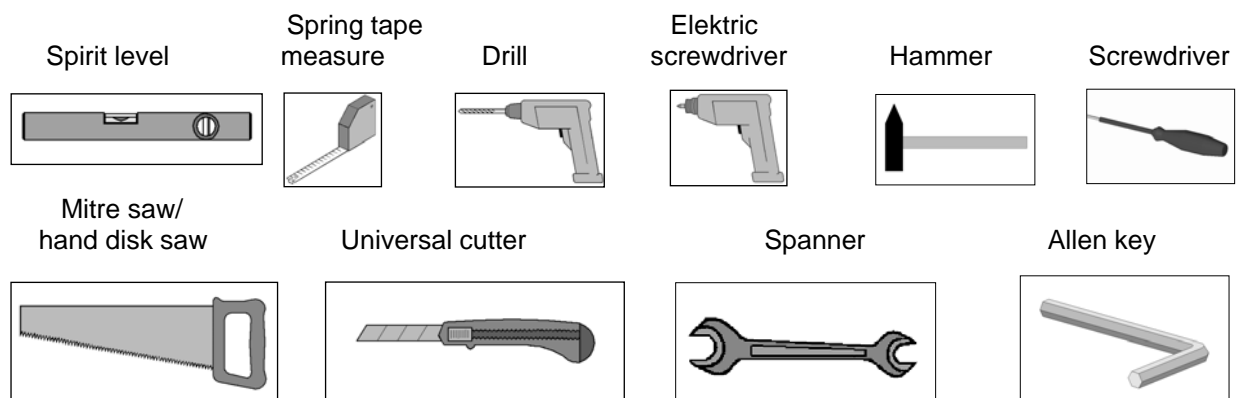

You should have the following tools to hand before beginning assembly.



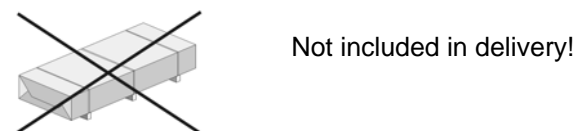

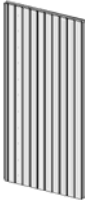
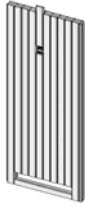

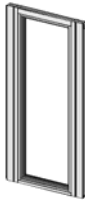

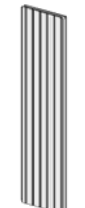
## Abbreviations / Symbols







Abb.	-	Figure
cm	-	Centimetre
mm	-	Millimetre
ca.	-	approximately/approx.





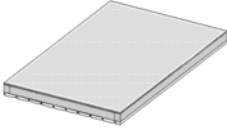





Pos	Bild	Abmessung [mm]	Anzahl [Stück]			
				2520W0	2520W1	
①		910 x 1916		2	-	
②		910 x 1916		3	3	
③		910 x 1916		1	-	
④		910 x 1916		1	1	
⑤		910 x 1916		1	-	
⑥		678 x 1916		-	1	
⑦		500 x 1916		1	1	



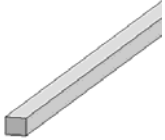
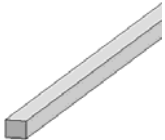
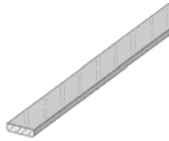

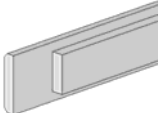
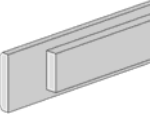
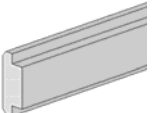

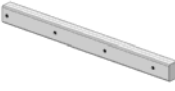

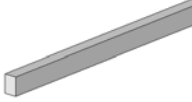

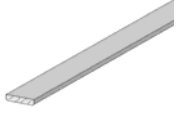
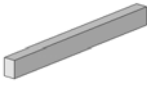
Pos	Bild	Abmessung [mm]	Anzahl [Stück]			
				2520W0	2520W1	
8		500 x 1916		1	1	
9		585 x 1916		-	2	
10		650 x 1916		-	1	
11		524 x 1916		-	1	
12		650 x 1916		-	1	
13				-	-	
14		590 x 1853	-	1	1	-

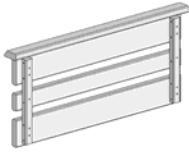
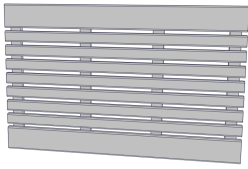

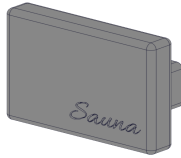

Pos	Bild	Abmessung [mm]	Anzahl [Stück]			
				2520W0	2520W1	
15		550 x 2285		2	2	
16	option 	500 x 1239		1	1	
17		1142 x 1785		2	2	
18		40/25//2400		1	1	
19		40/25/2400		3	3	
20		40/25/1900		4	4	
21		40/40/1890		4	4	

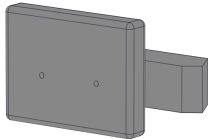
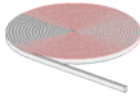
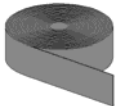



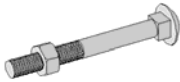

Pos	Bild	Abmessung [mm]	Anzahl [Stück]			
				2520W0	2520W1	
22		14/35/1915		9	12	
23		14/67/1915		3	3	
24		14/54/1915		1	1	
25		14/14/1915		7	7	
26		30/30/2232		2	2	
27		30/30/1792		2	2	
28		14/54/1728		1	1	

Pos	Bild	Abmessung [mm]	Anzahl [Stück]			
				2520W0	2520W1	
29		28/66/1500		1	1	
30		28/66/1240		1	1	
31		28/66/1930		1	1	
32		25/40/80		4	4	
33		25/40/520		2	2	
34		25/40/1090		2	2	
35		25/40//1225		1	1	

Pos	Bild	Abmessung [mm]	Anzahl [Stück]			
				2520W0	2520W1	
36		15/45/450		1	1	
37		25/40/470		1	1	
38		323 x 260		2	2	
39		462 x 350		2	2	
40		595 x 268		1	1	
41		1000 x 615		1	1	
42		410 x 235		1	1	

Pos	Bild	Abmessung [mm]	Anzahl [Stück]			
				2520W0	2520W1	
43				1	1	
44				2	2	
45				1	1	
46		10m		2	2	
47		10m		1	1	
48				2	2	
49				1	1	

Pos	Bild	Abmessung [mm]	Anzahl [Stück]			
				2520W0	2520W1	
50				1	1	
51		5,0 x 100		2	2	
53		M6 x 60		2	2	
54		6,4		2	2	
56		4,5 x 70		50	50	

Pos	Bild	Abmessung [mm]	Anzahl [Stück]			
				2520W0	2520W1	
57		6,0 x 60		28	28	
58		4,0 x 60		10	10	
59		4,0 x 60		15	15	
60		3,5 x 35		50	50	
61		3,5 x 35		14	14	
62		3,0 x 30		30	30	
65		16 x 30		110	110	



# 2520W0

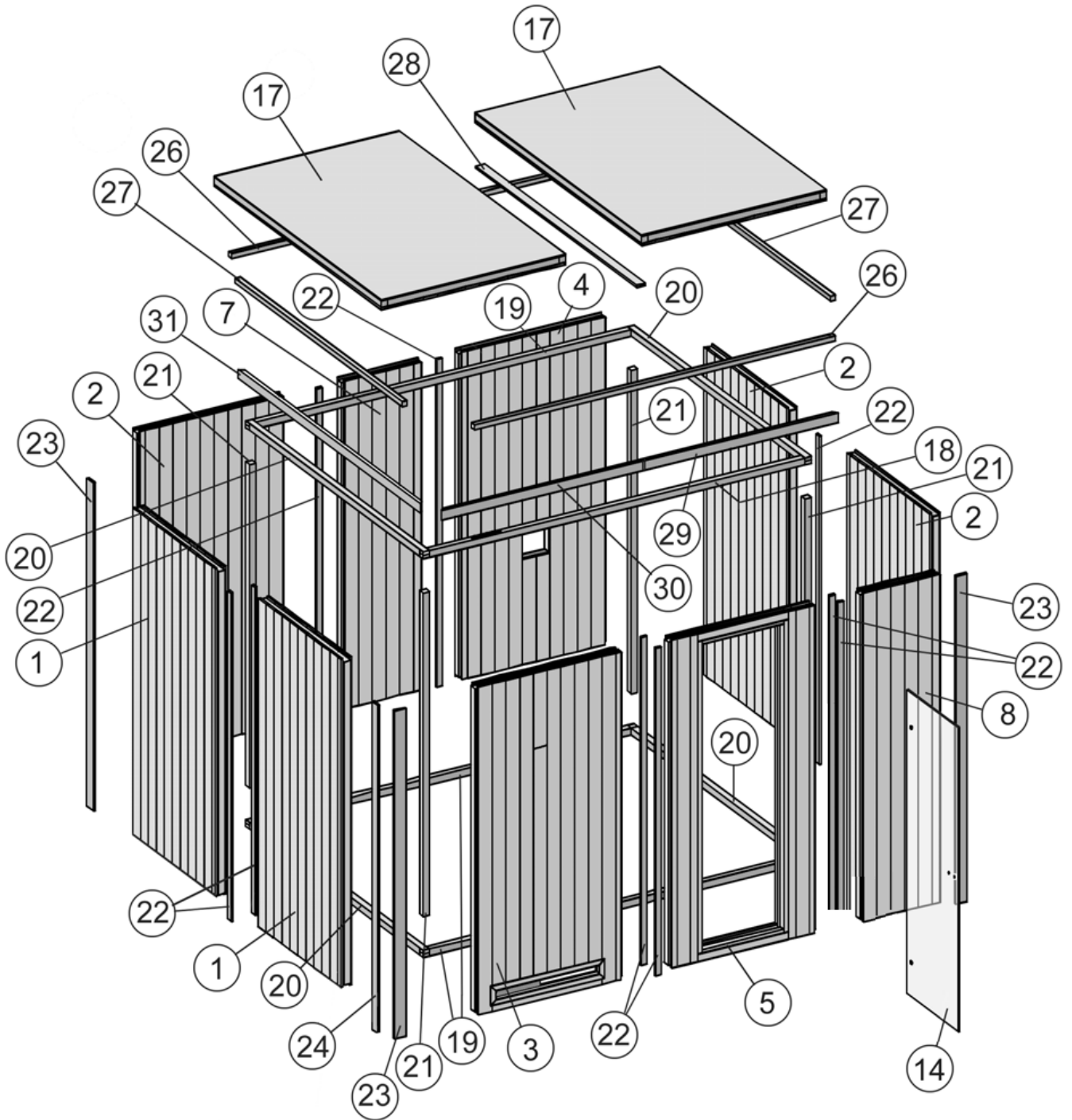

2520W0

**VARIA 1**

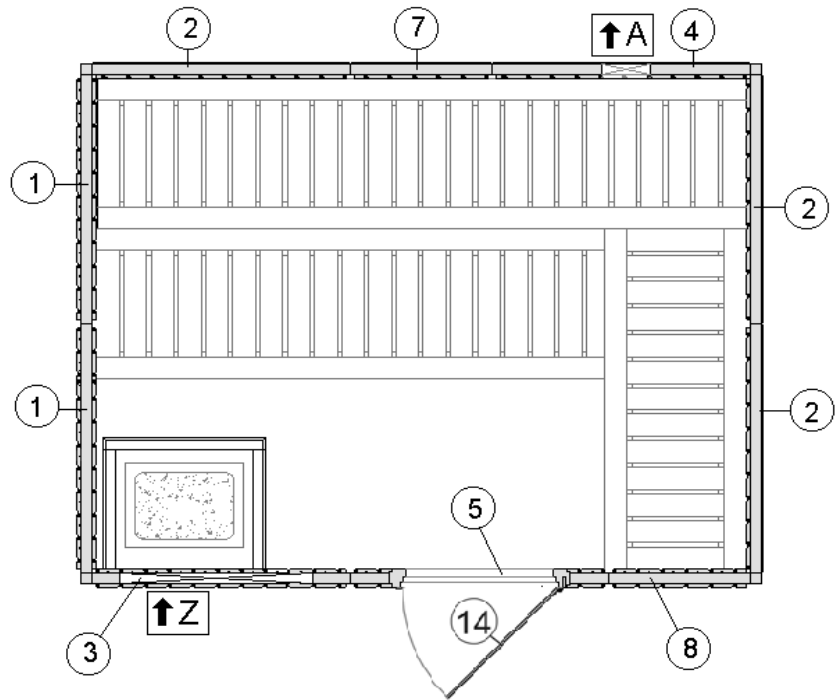

**VARIA 2**

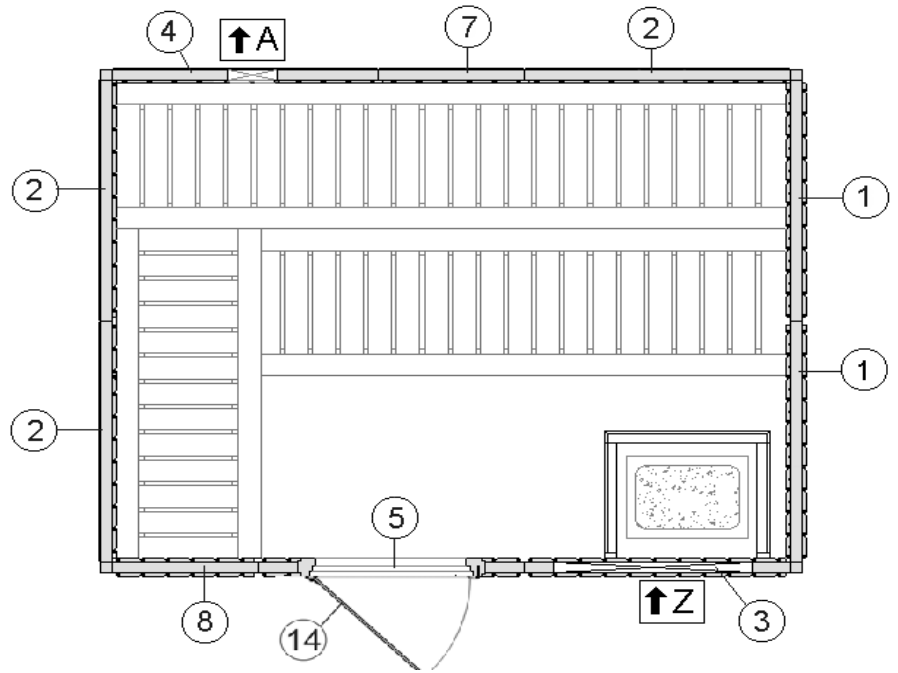

# 2520W1

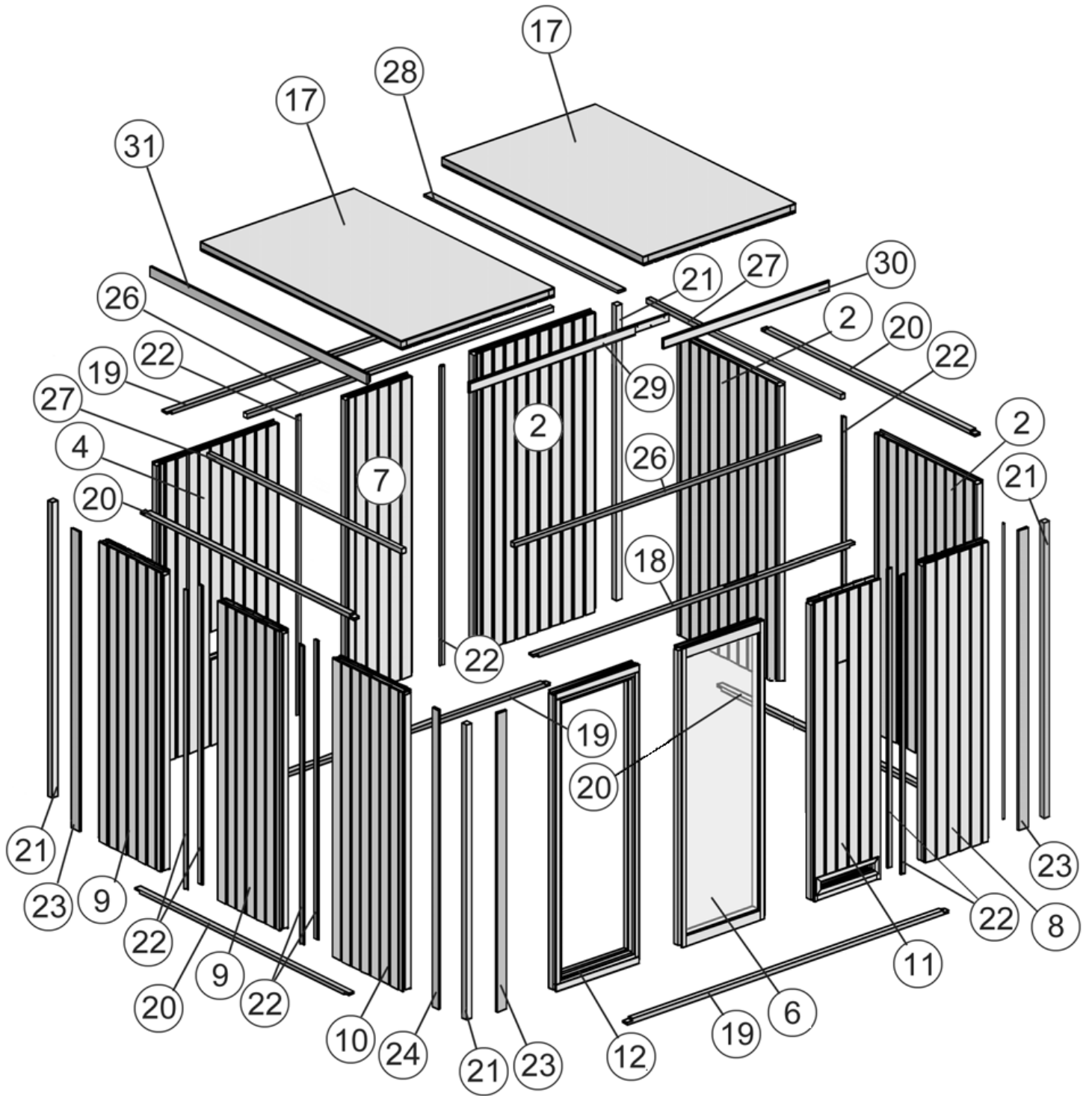

2520W1

**VARIA 1**

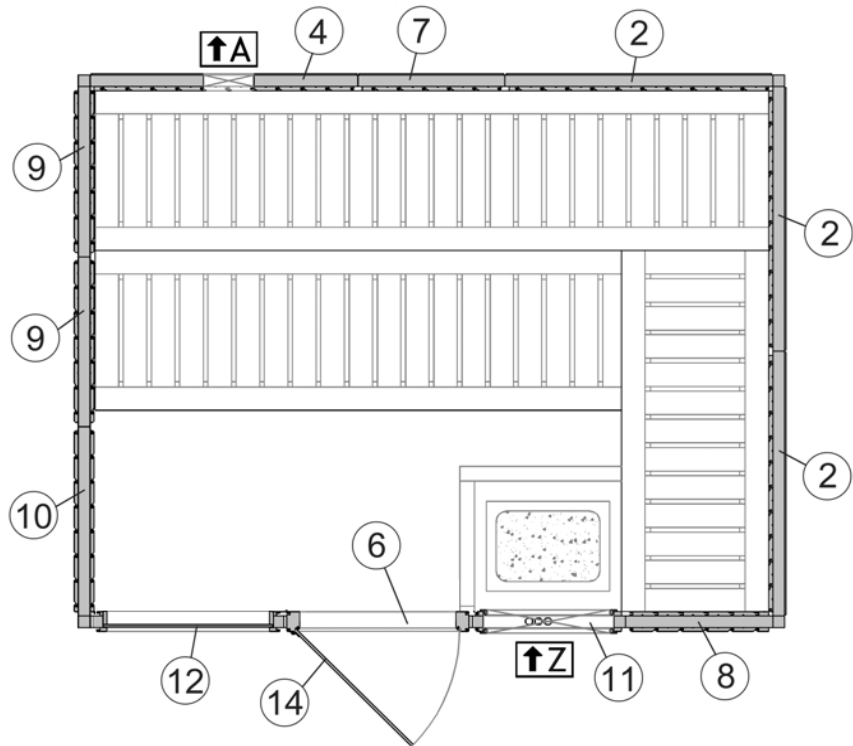

**VARIA 2**

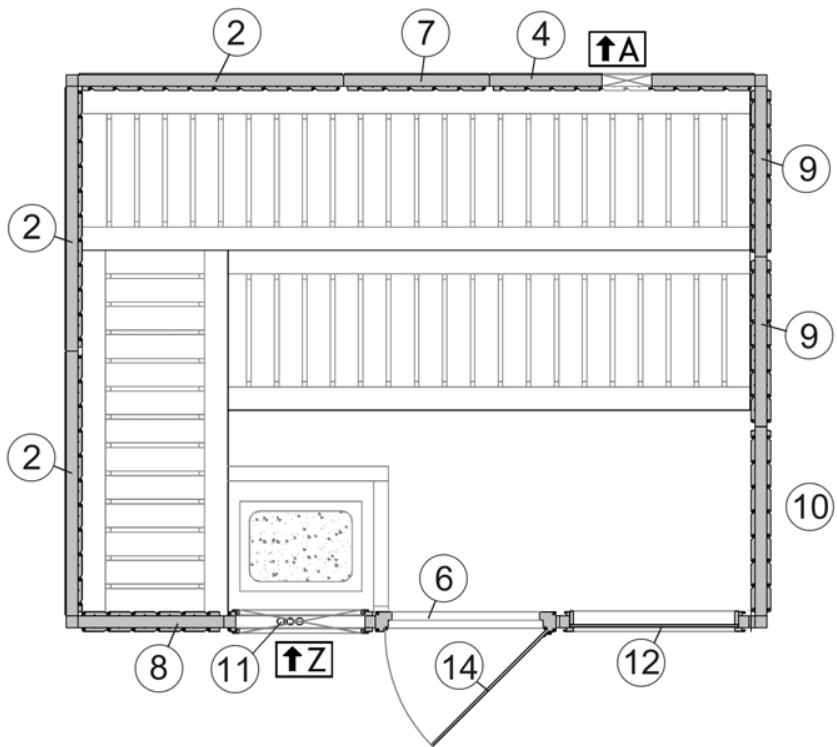

1

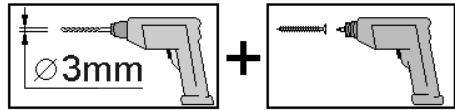
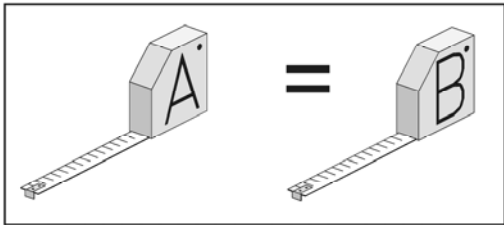
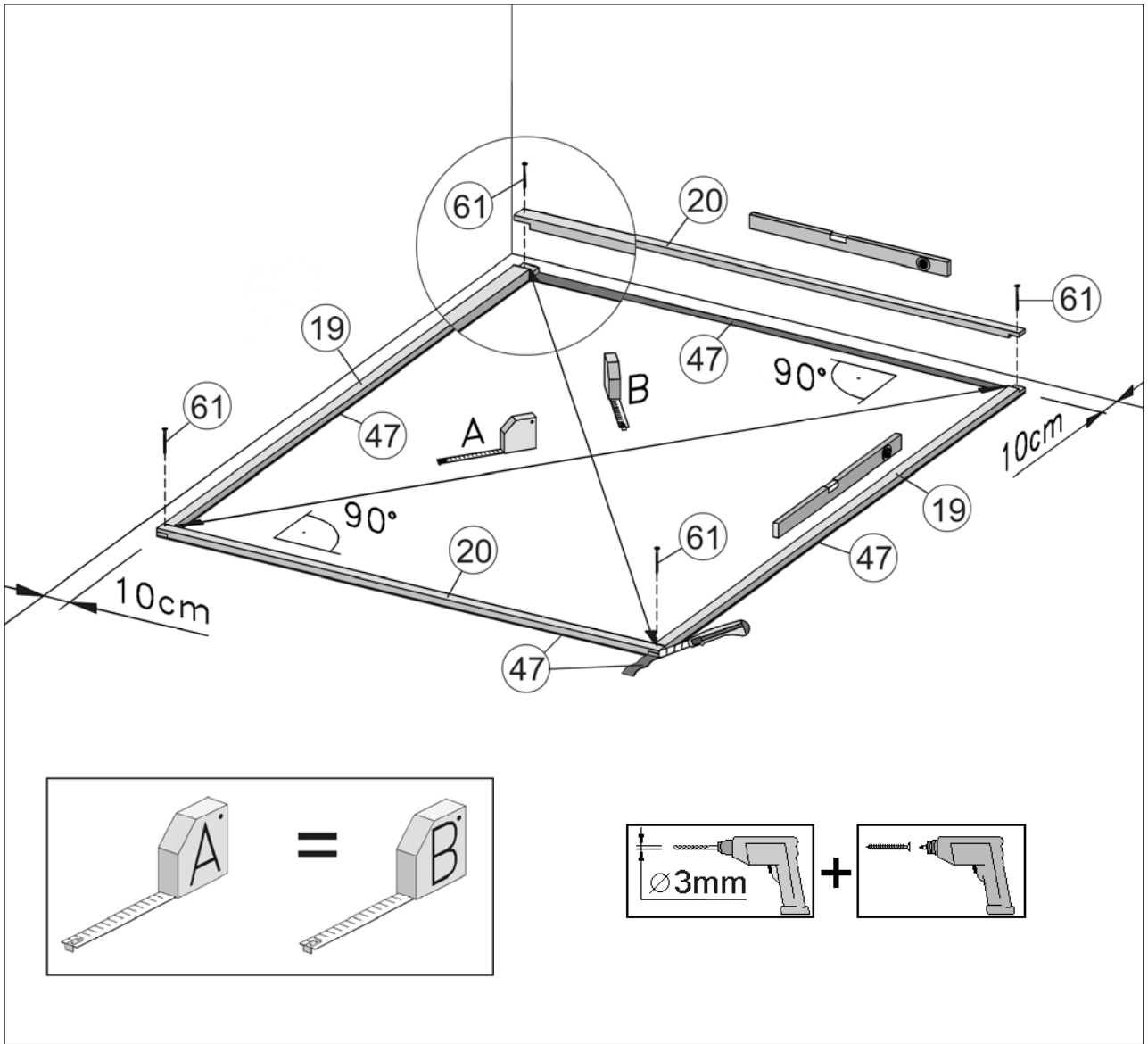
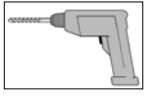
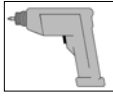
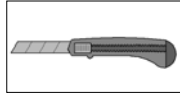
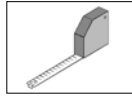
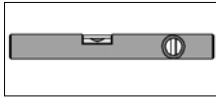

**2** 2520W0

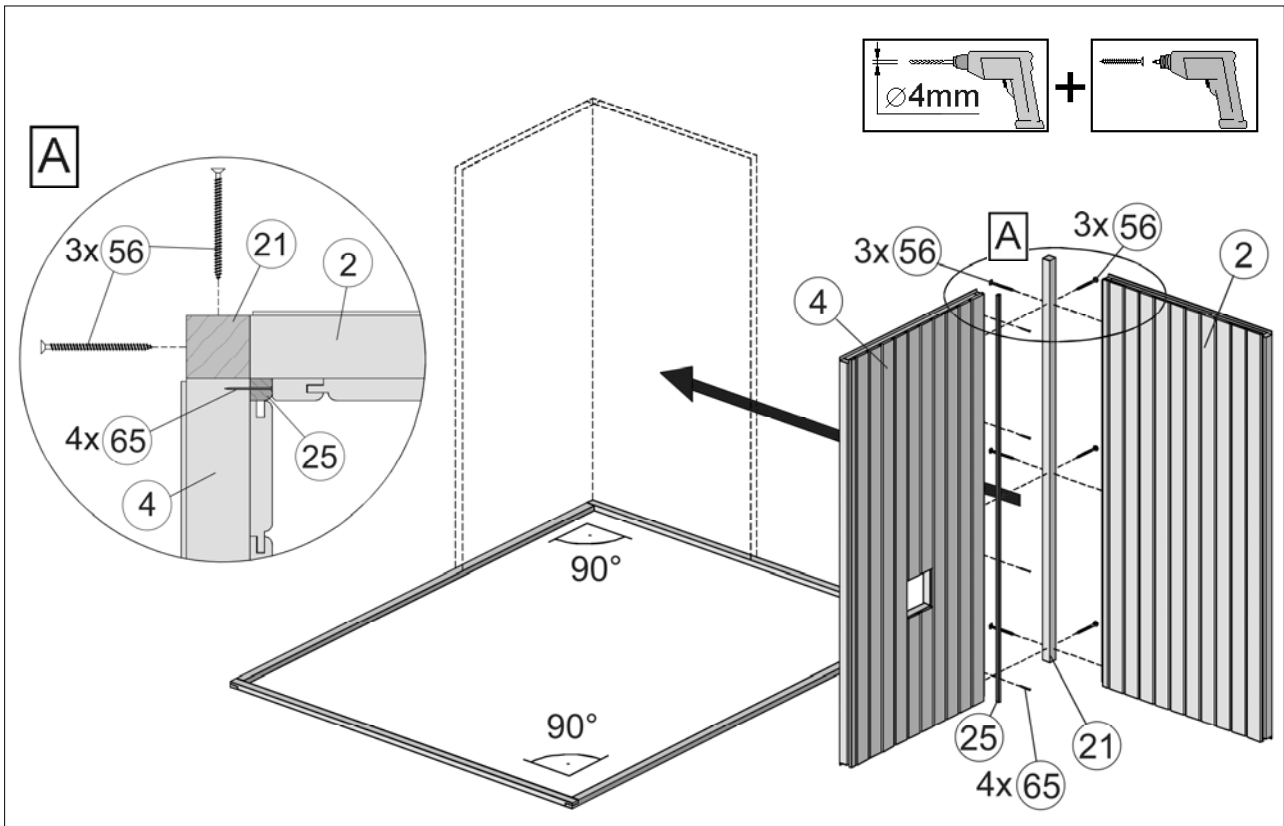
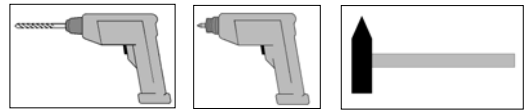

**2** 2520W1

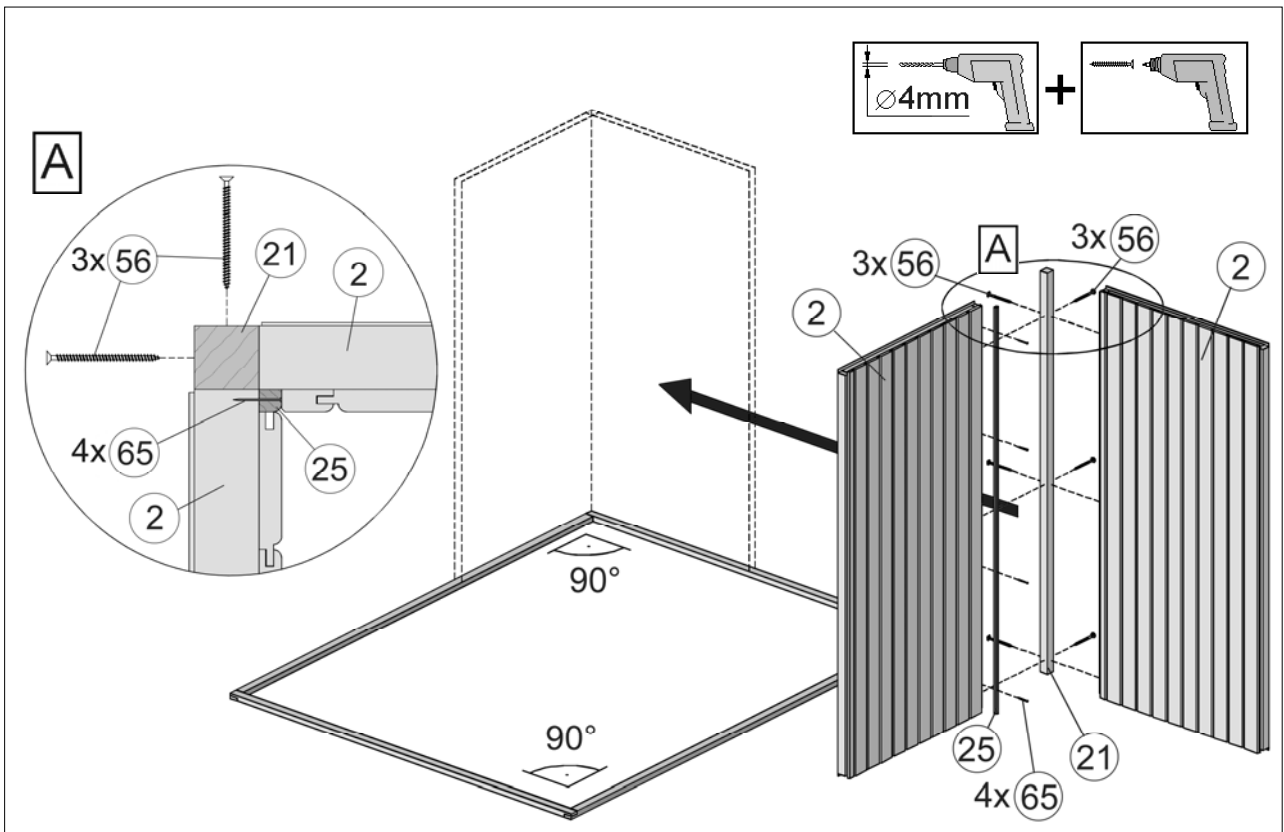
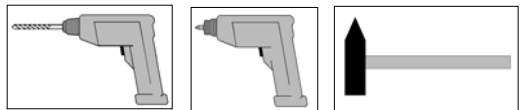

### 3 2520W0

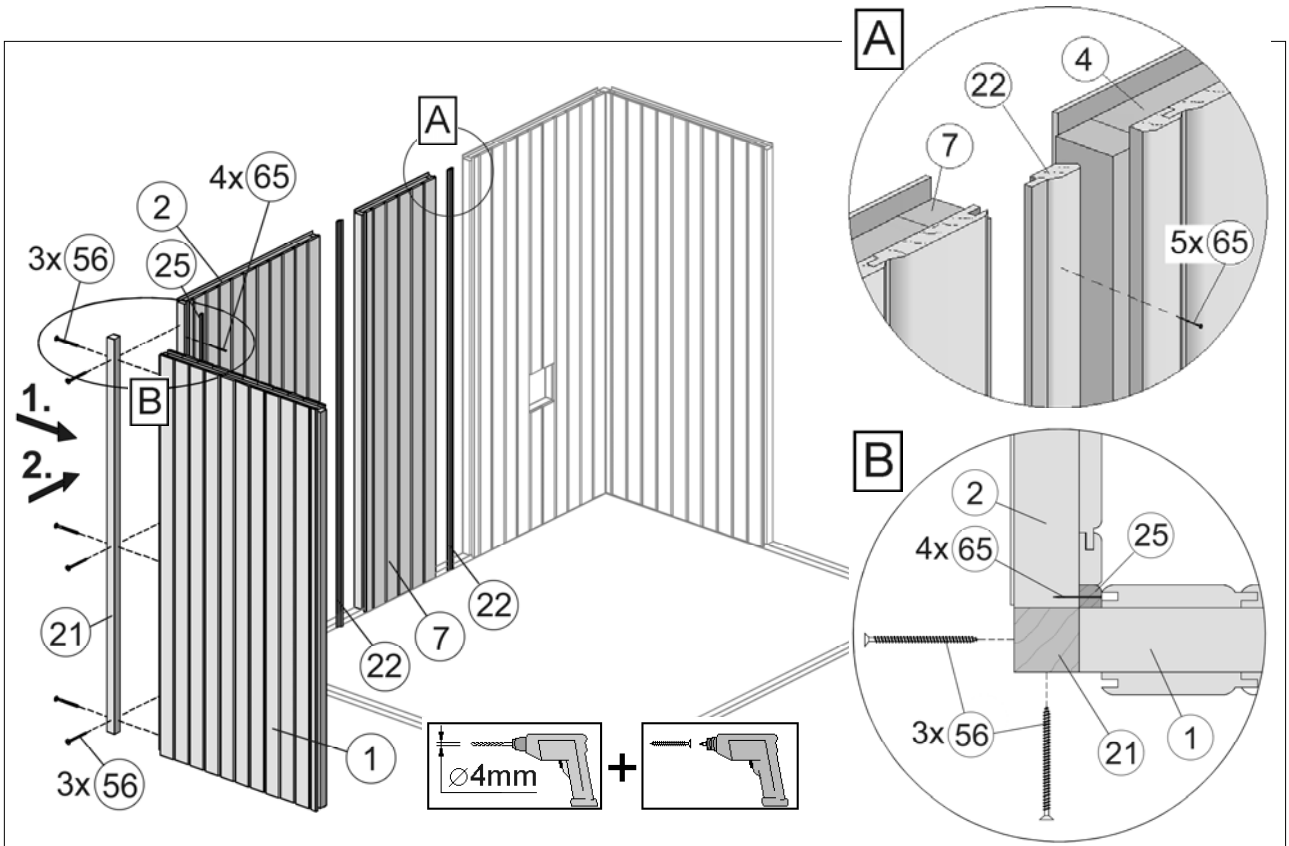
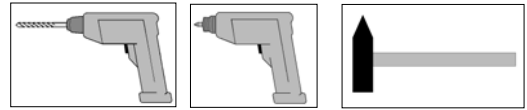

### 3 2520W1

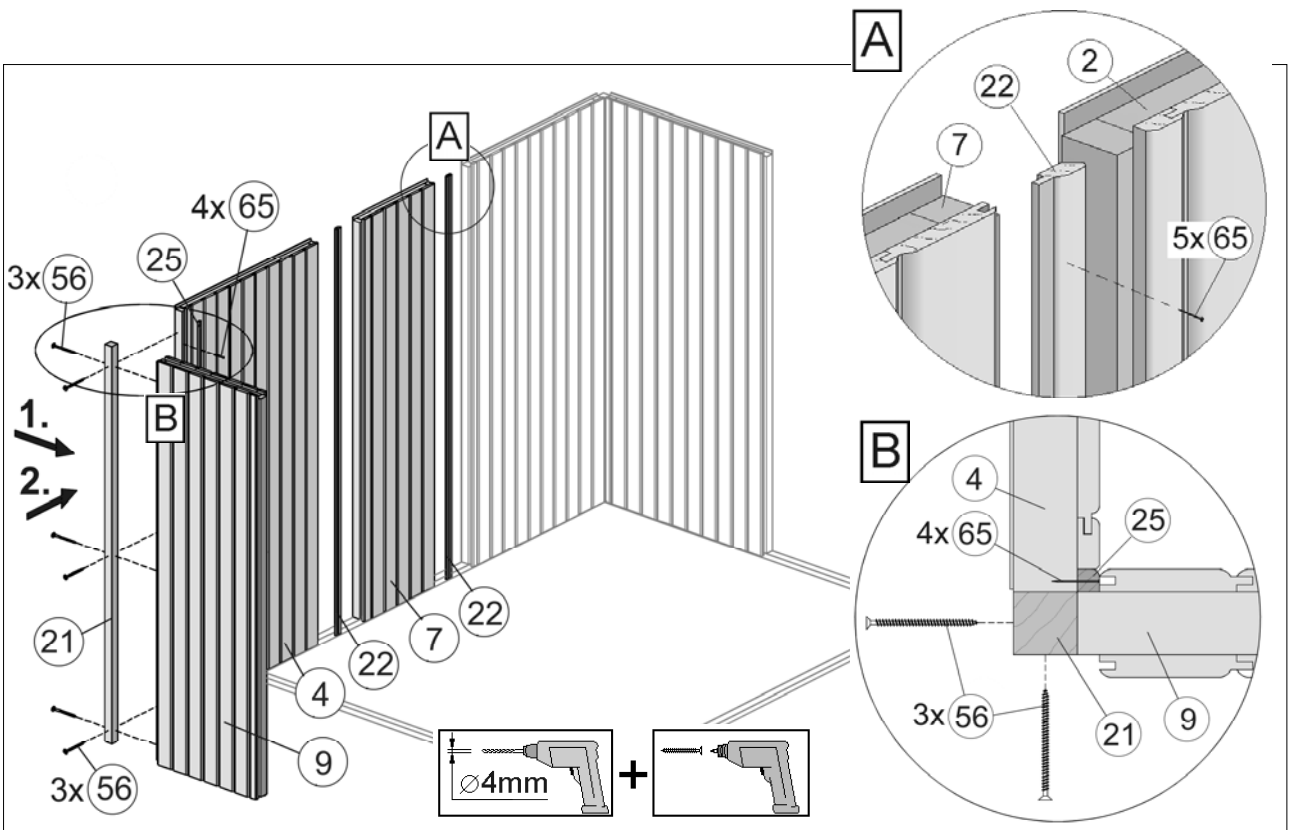
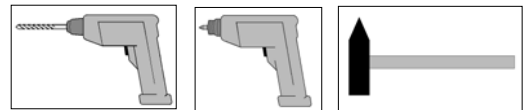

# 4 2520W0

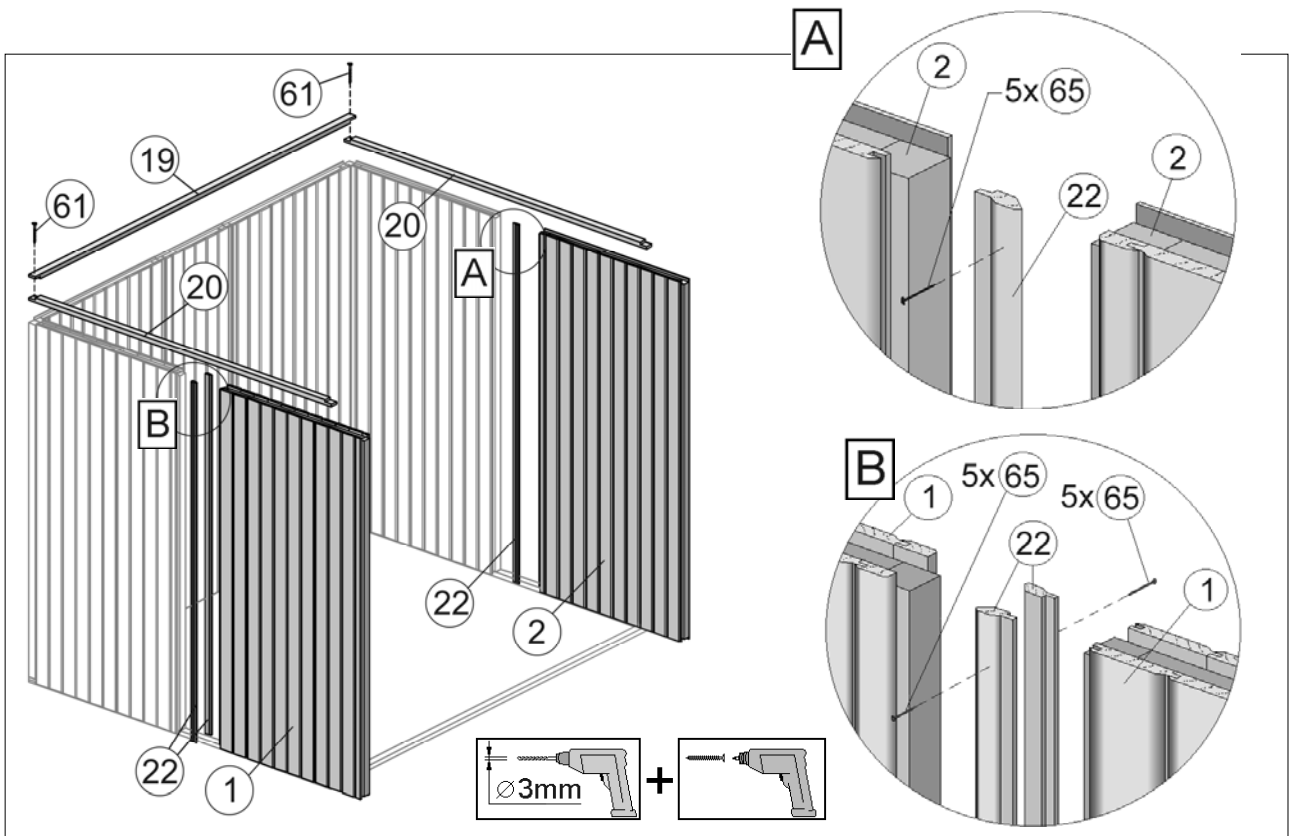
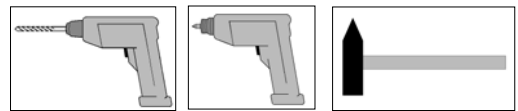

# 4 2520W1

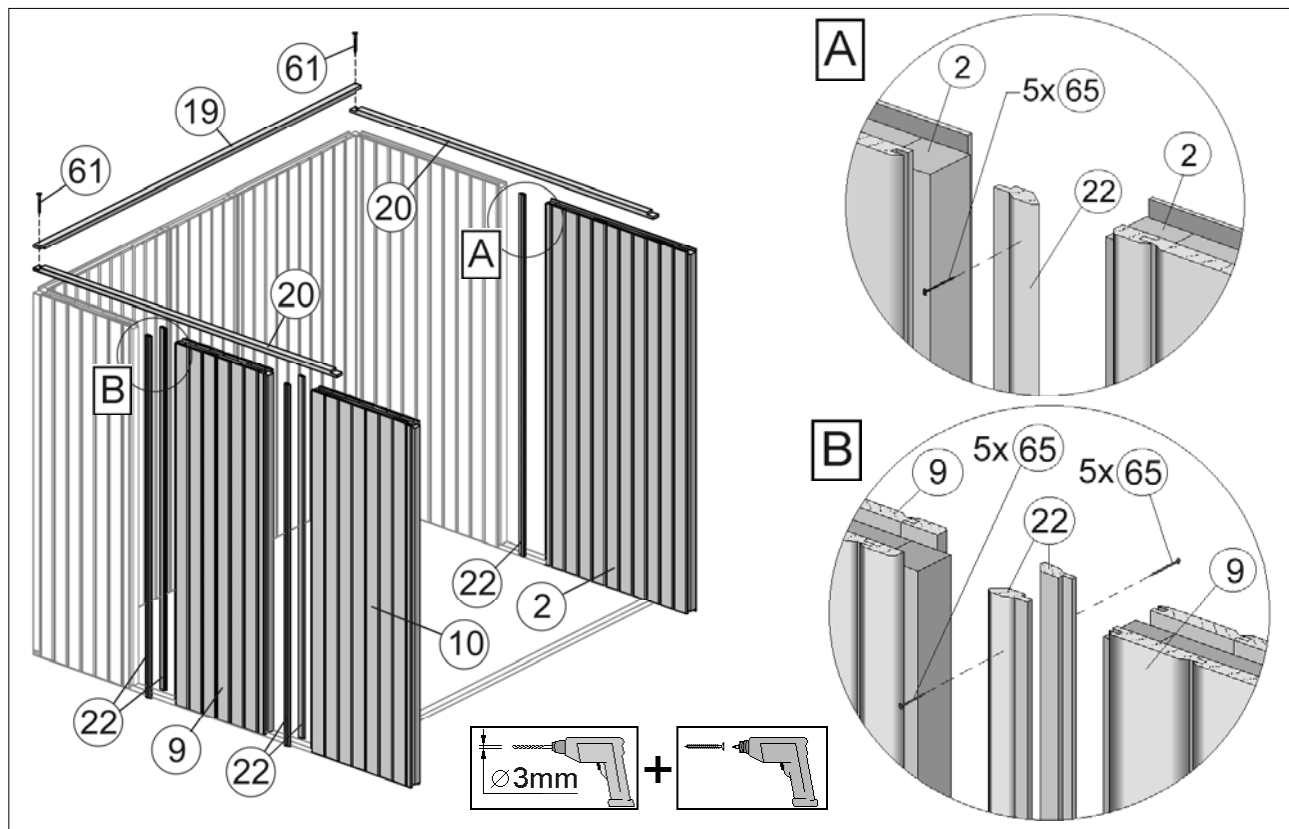
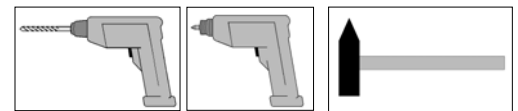



5

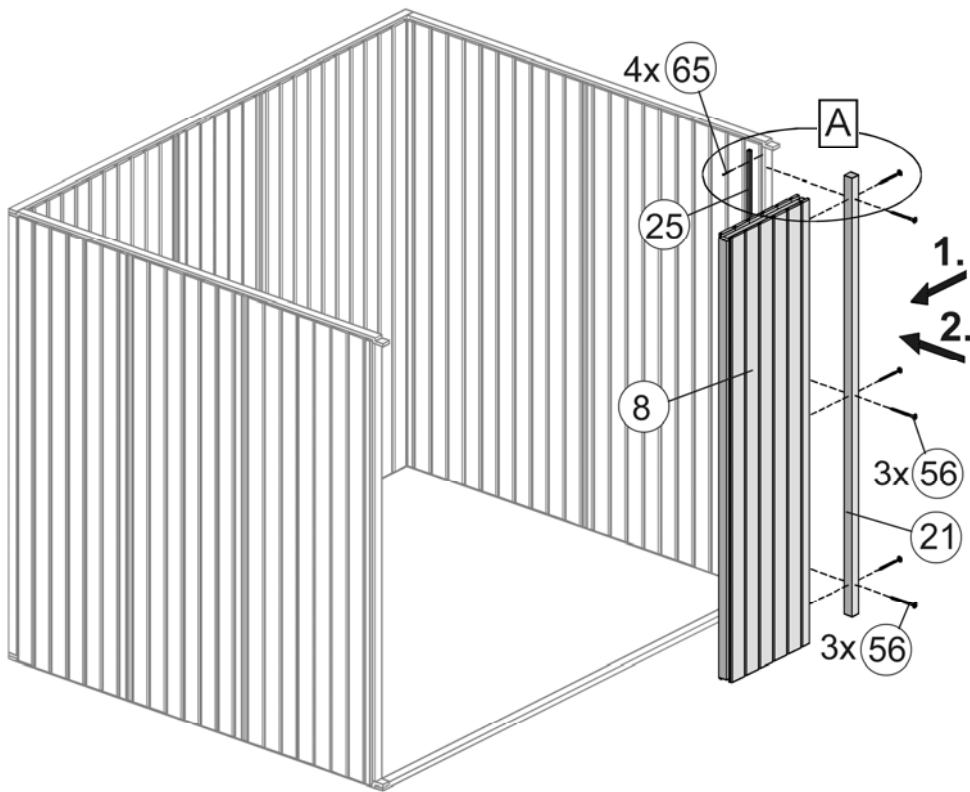
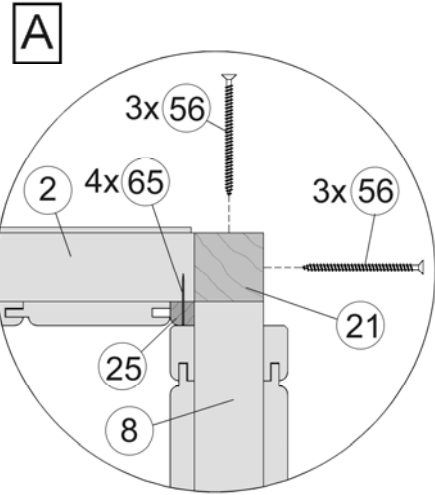
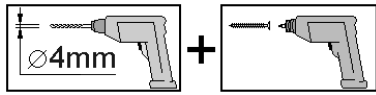
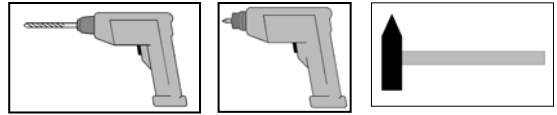

6

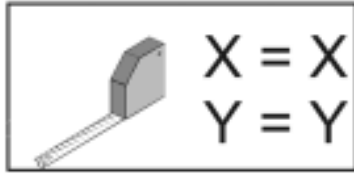
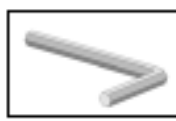
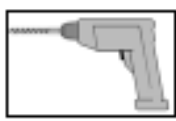
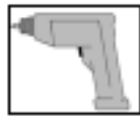
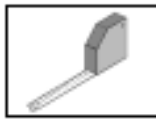

2520W0

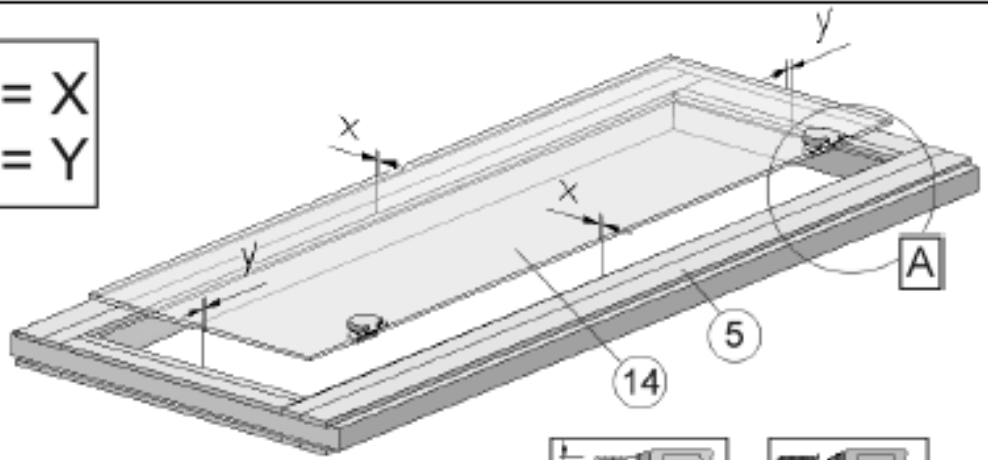

A-1

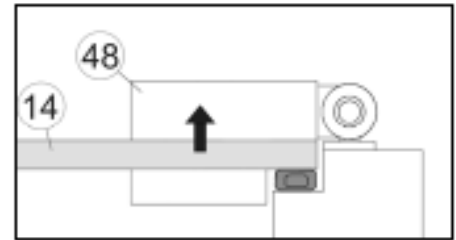
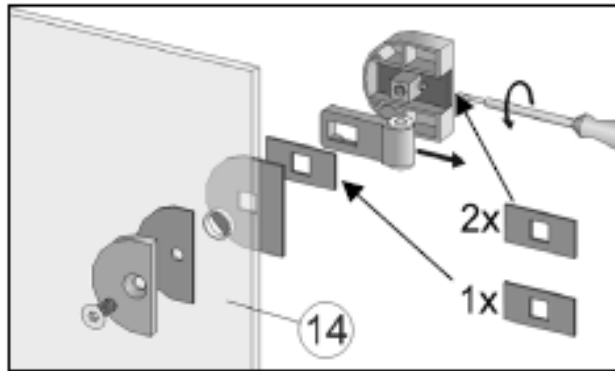
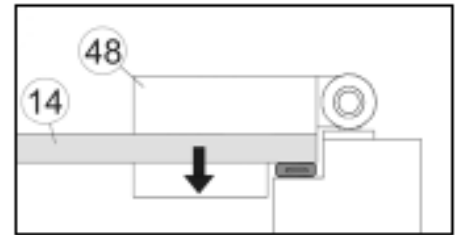
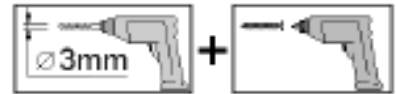
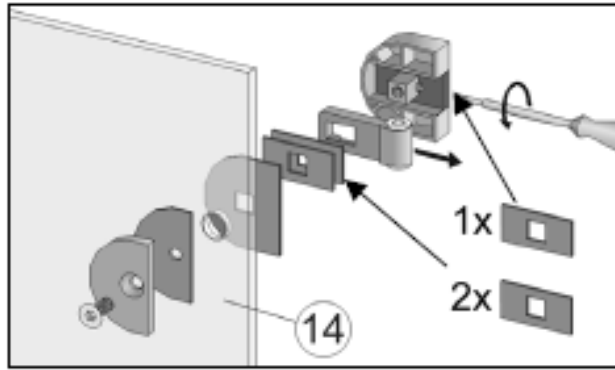

A-2

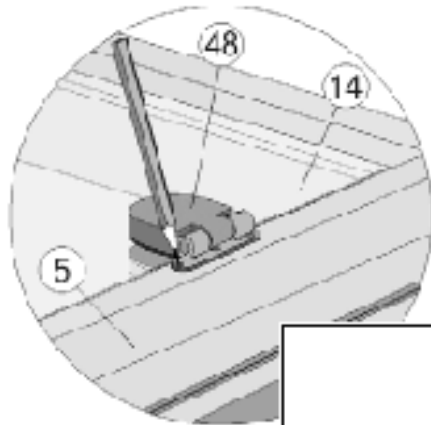

A-3

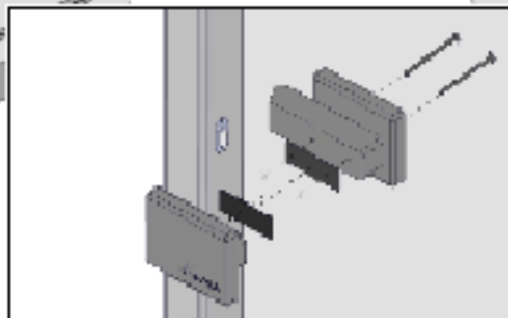
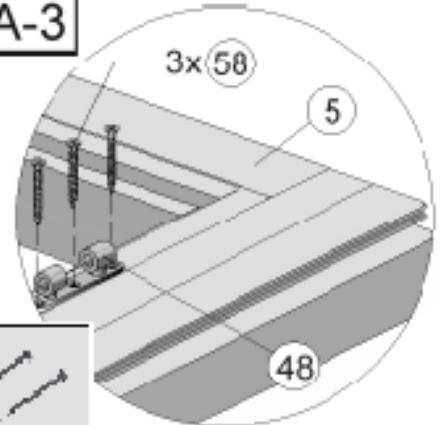

6

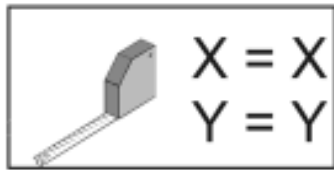
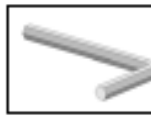
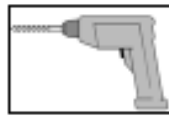
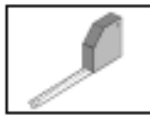

2520W1

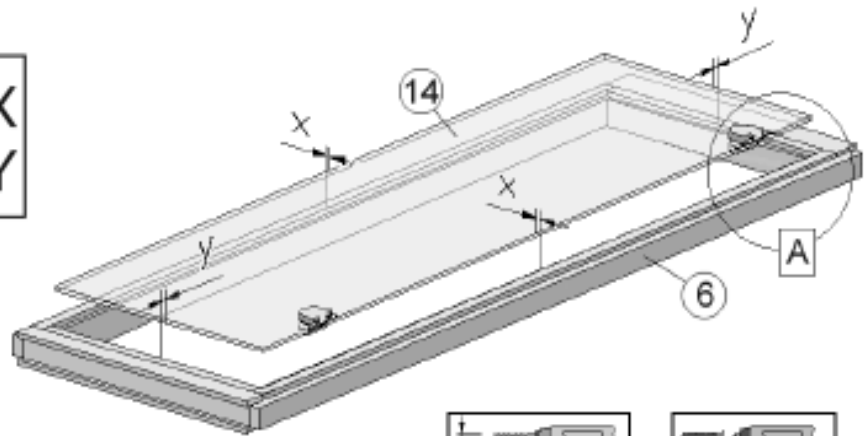

A-1

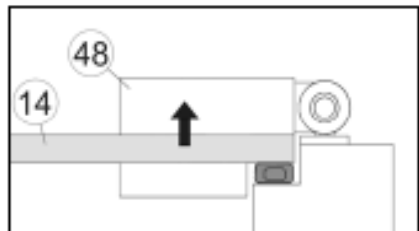
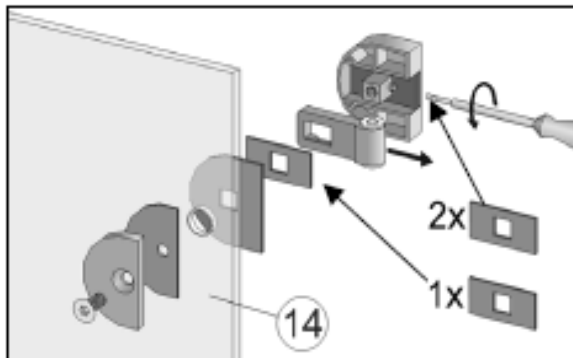
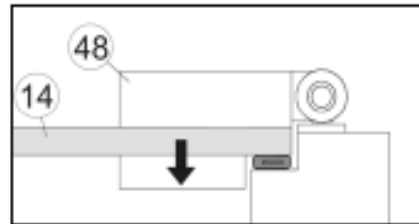
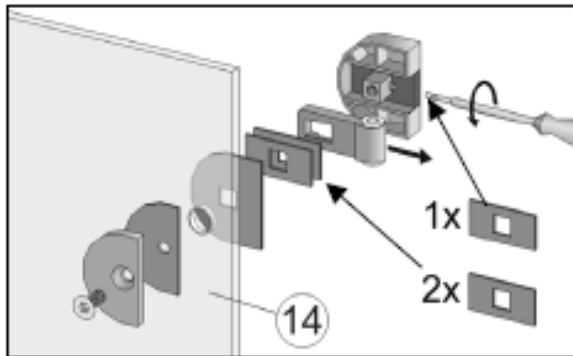

A-2

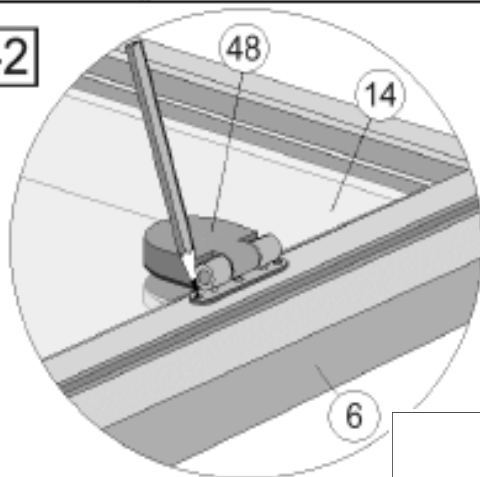

A-3

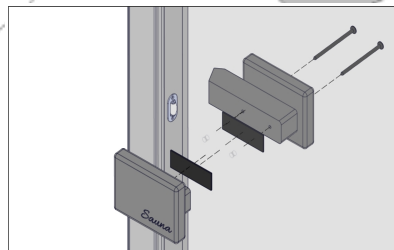
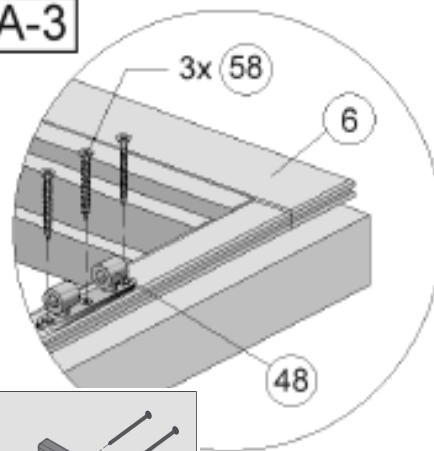

# 7 2520W0

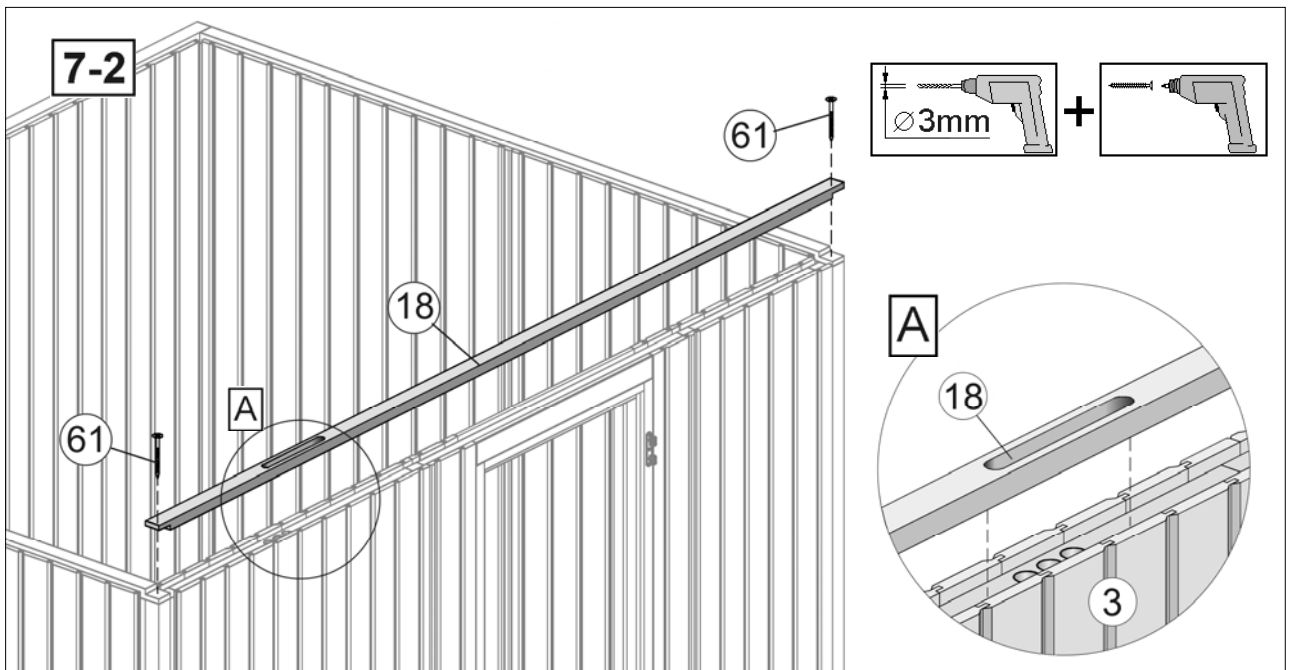
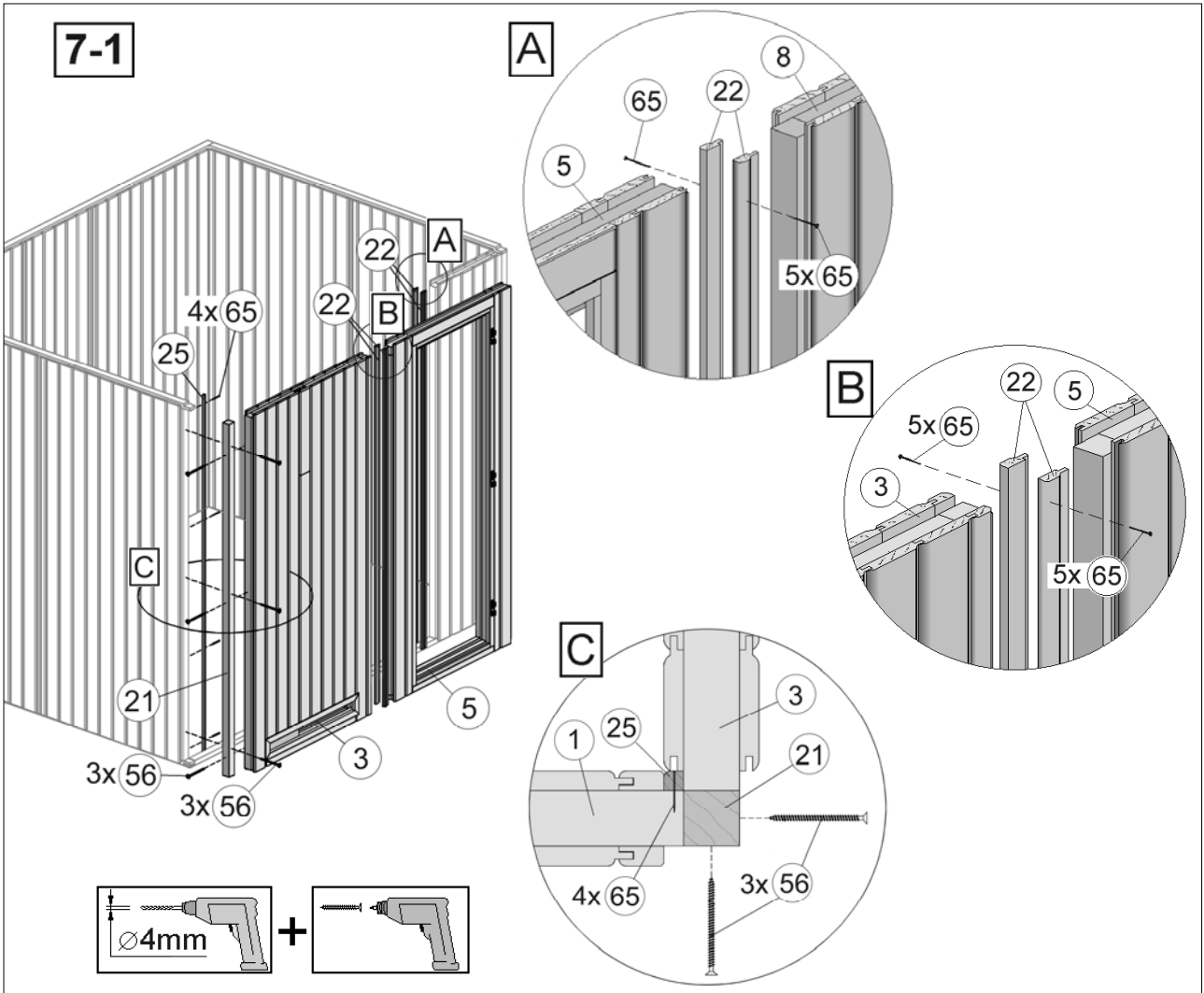
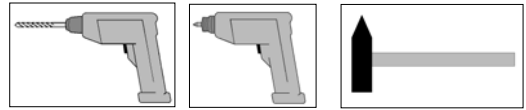

**7** 2520W1

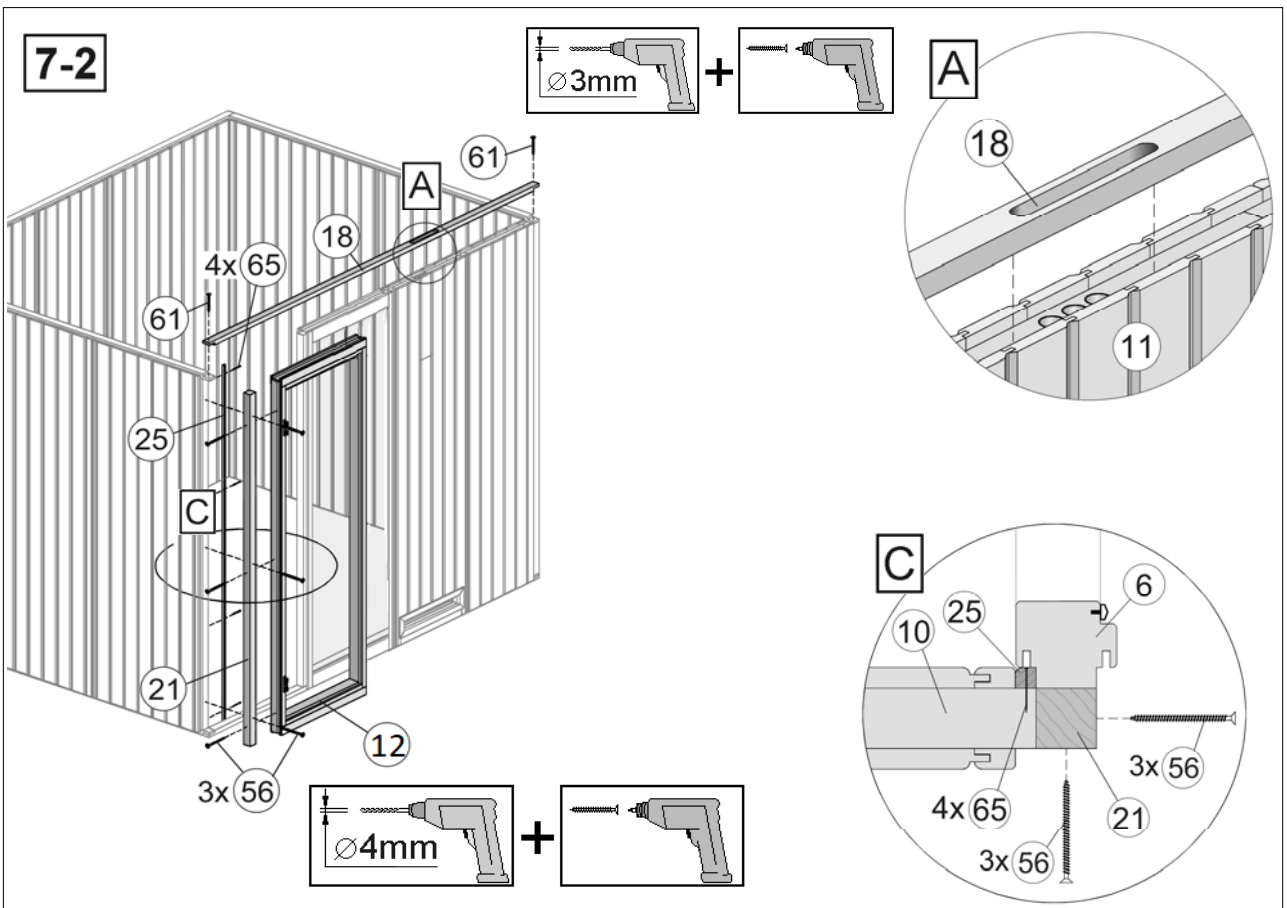
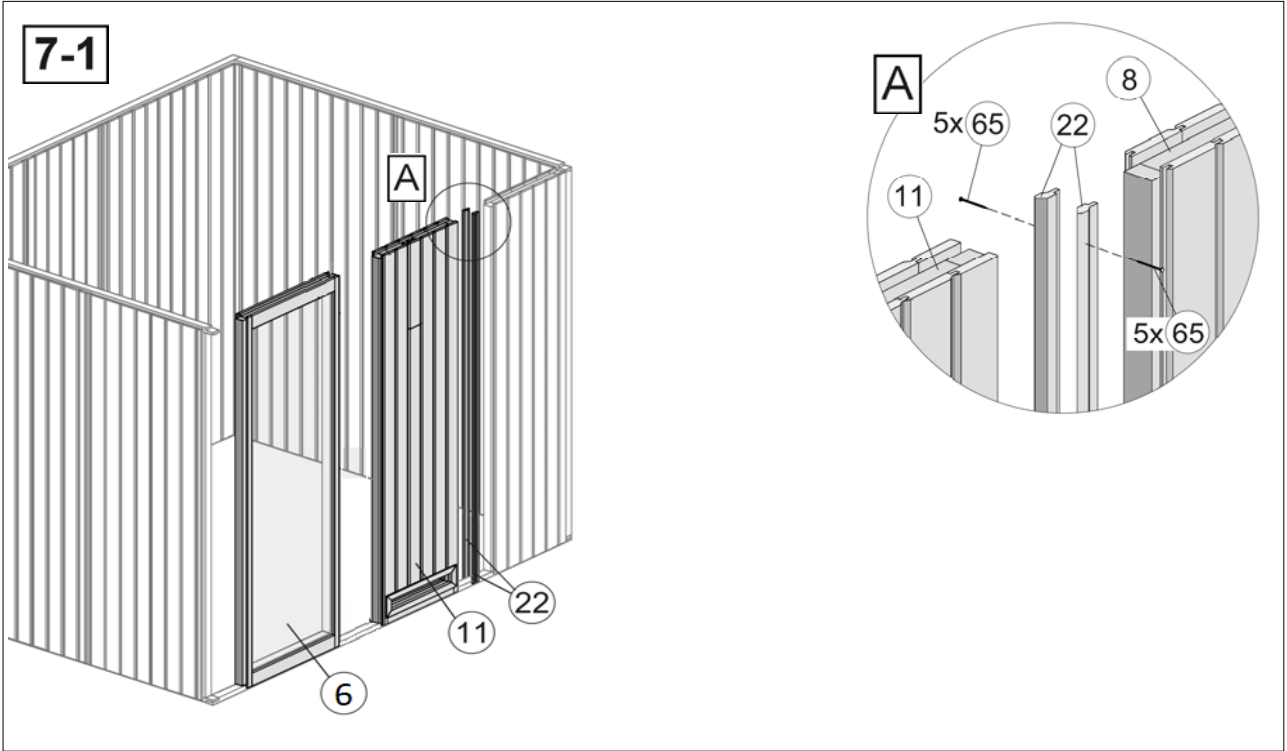
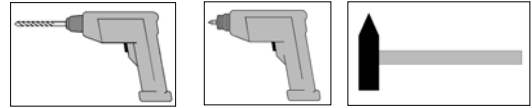

**8** 2520W0

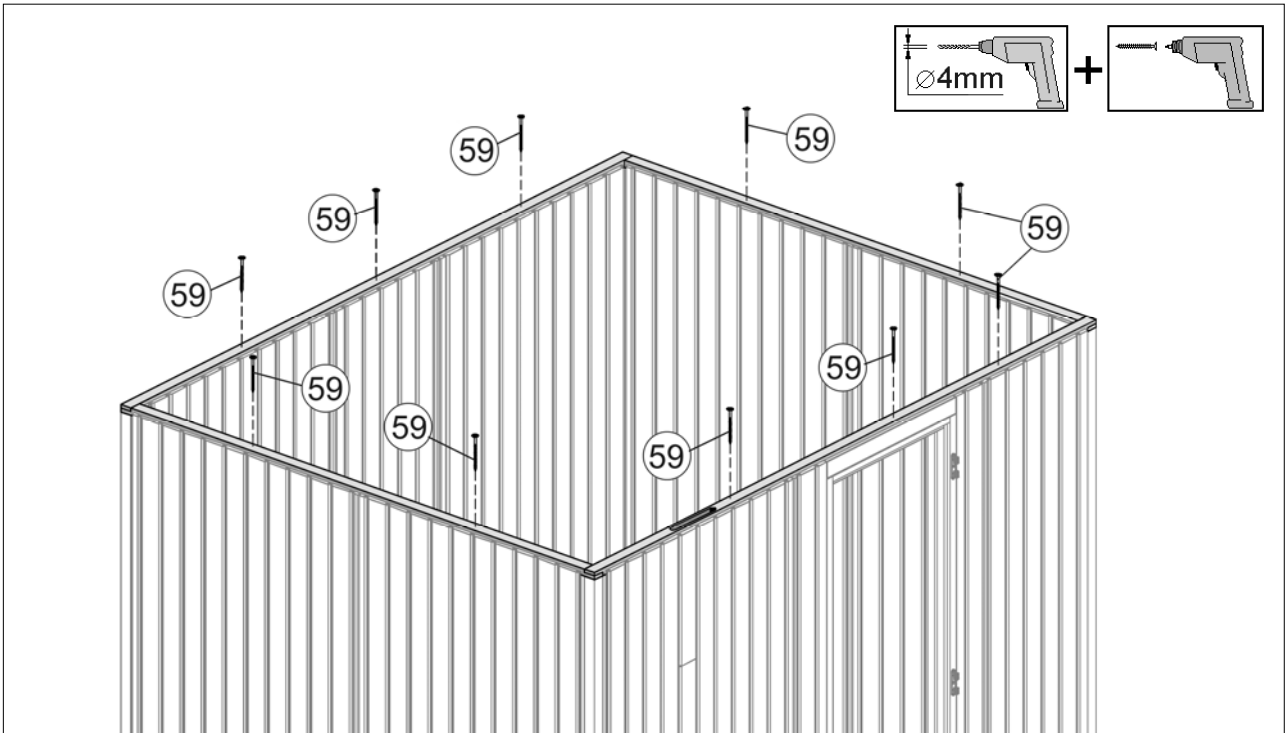
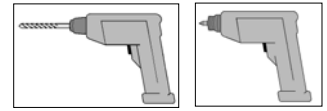

**8** 2520W1

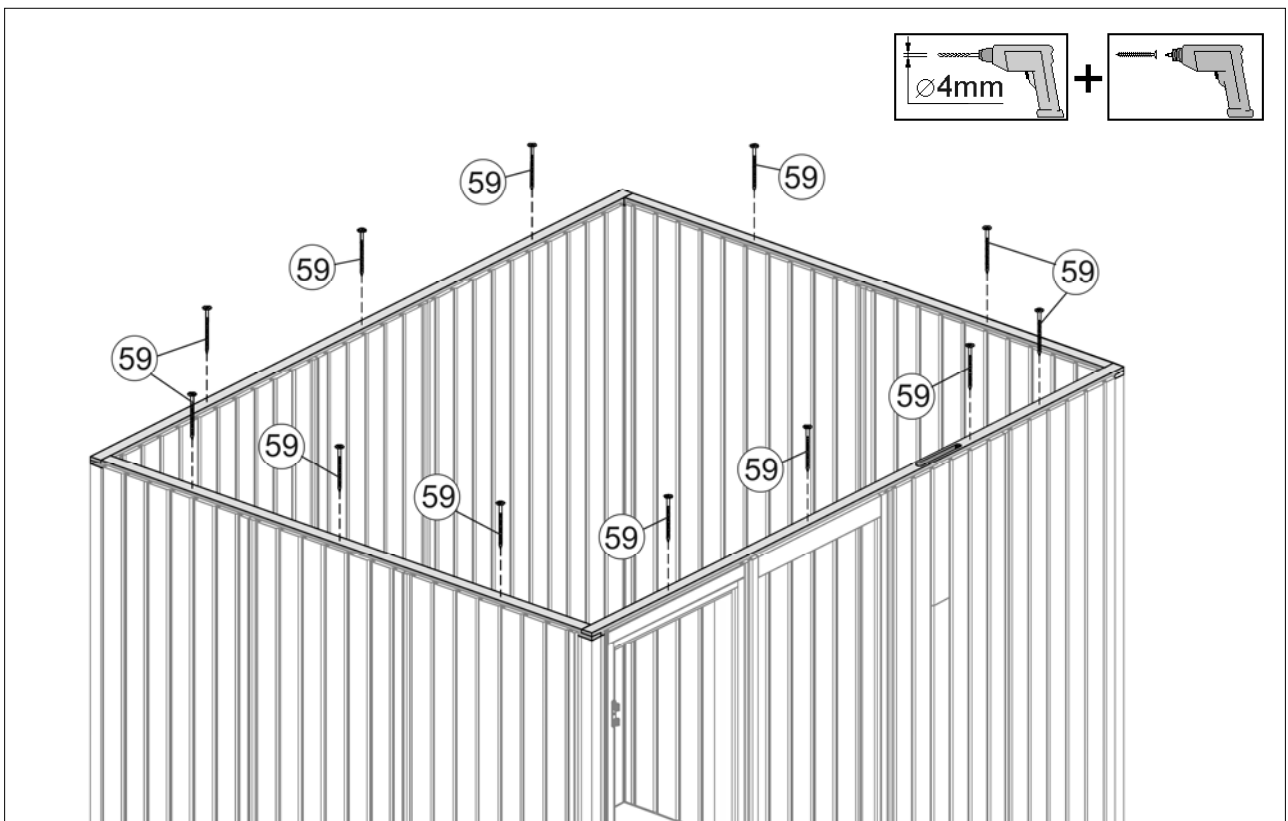
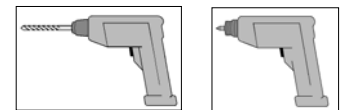

9

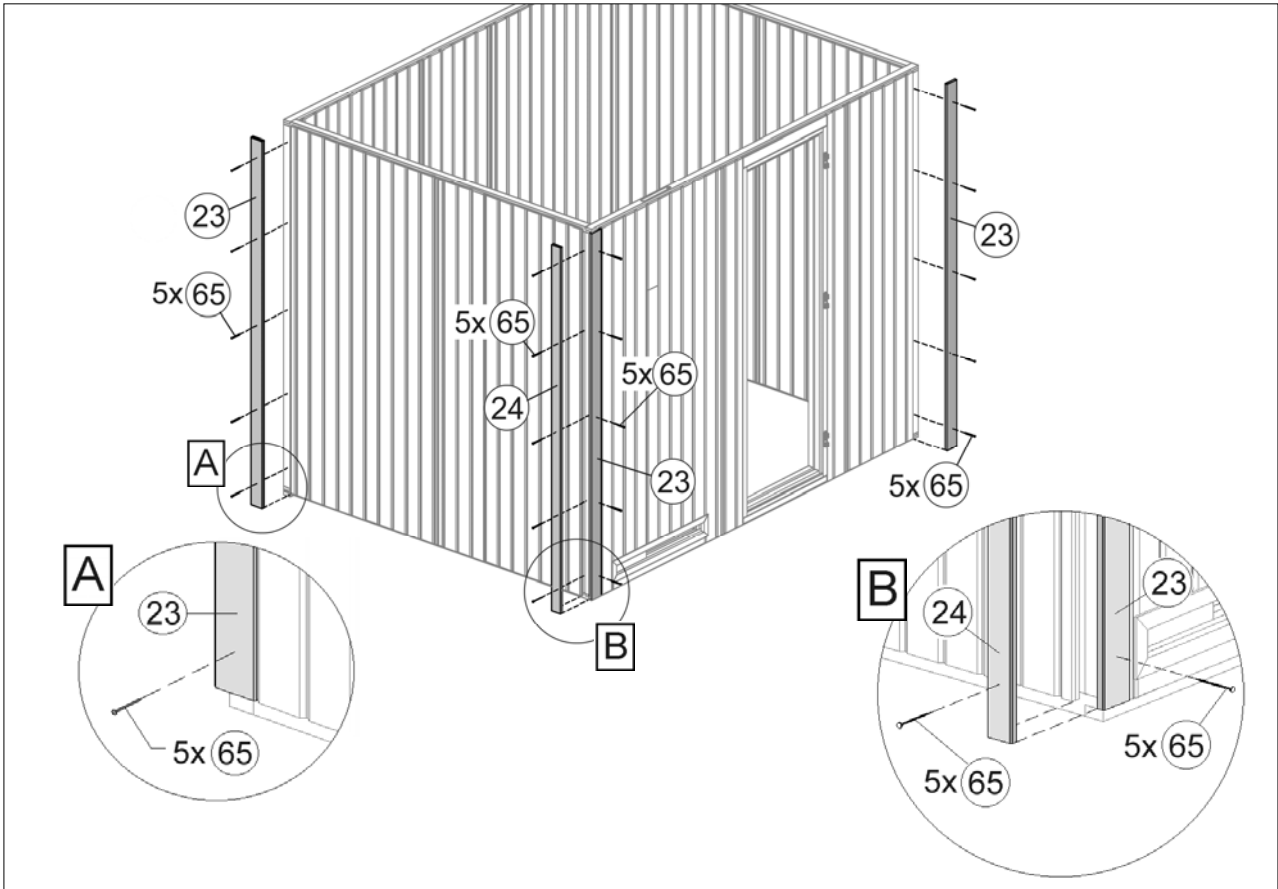
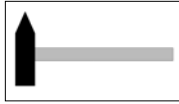

10

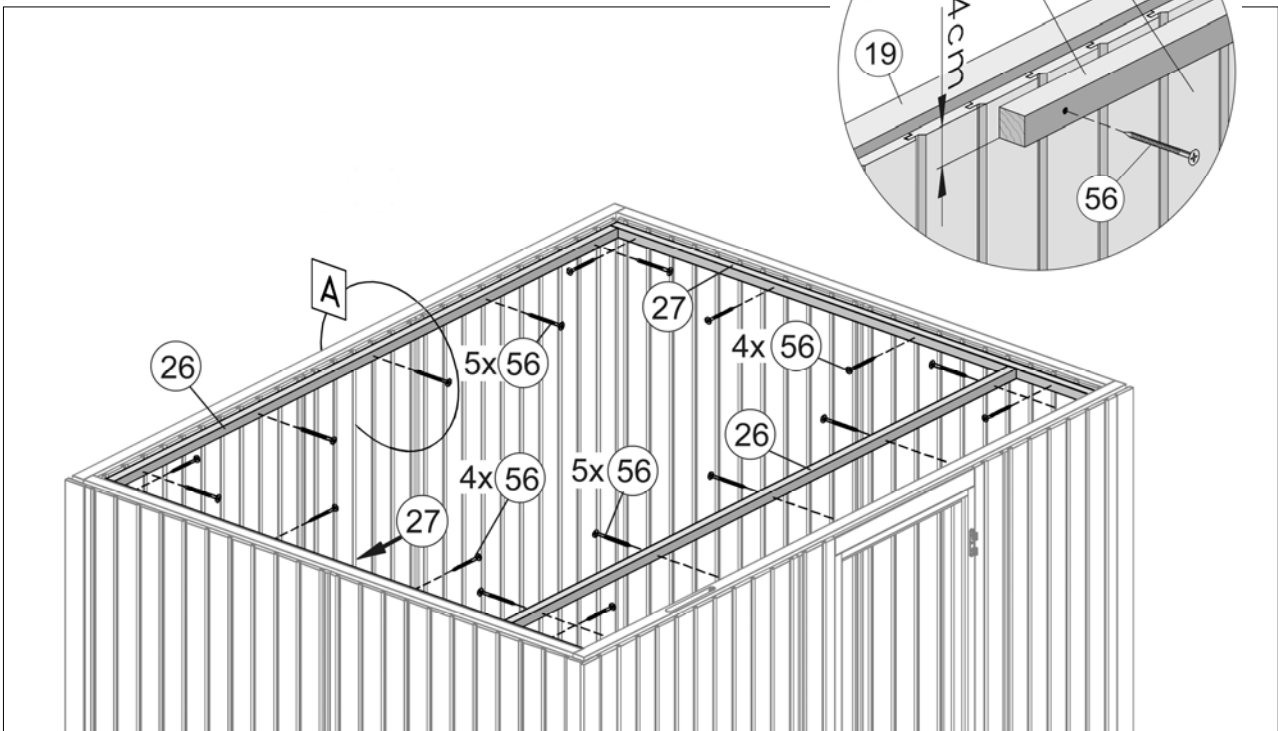
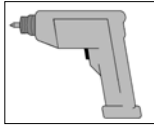
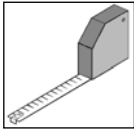

11

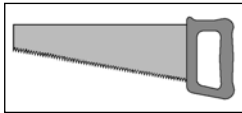
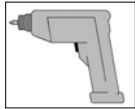
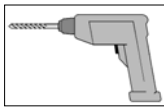

1.

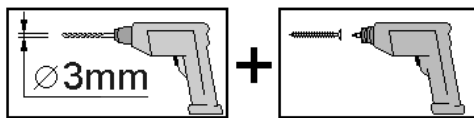
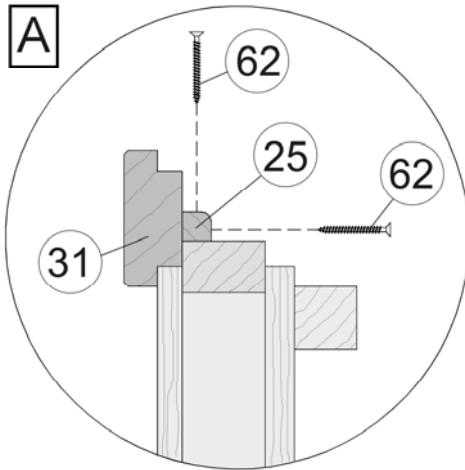
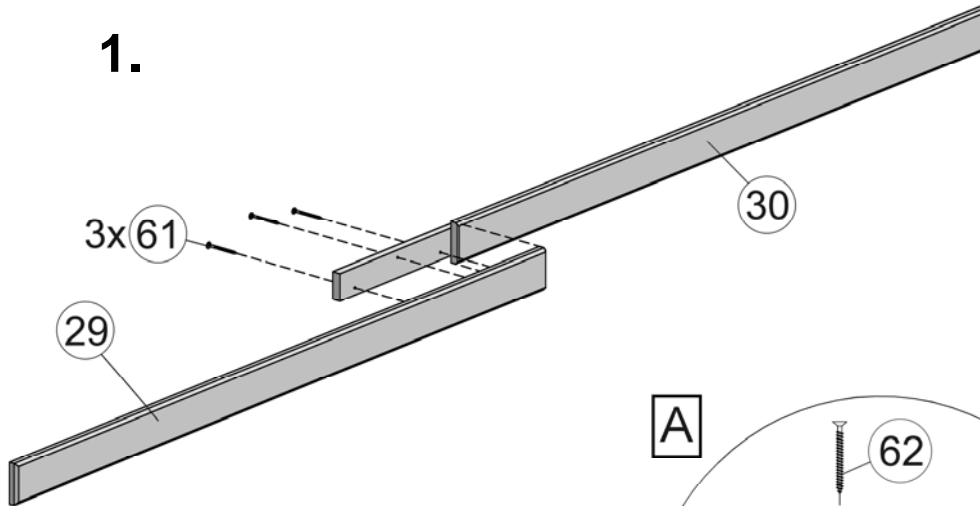

2.

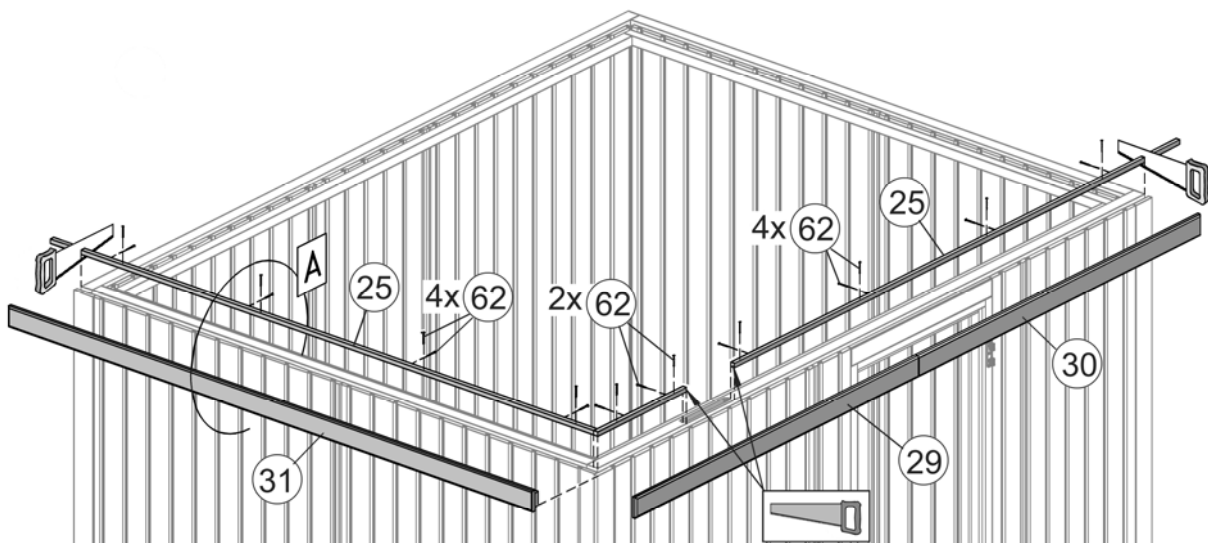



**12**

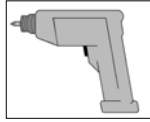
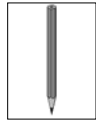
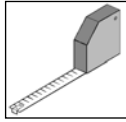

**12.1**

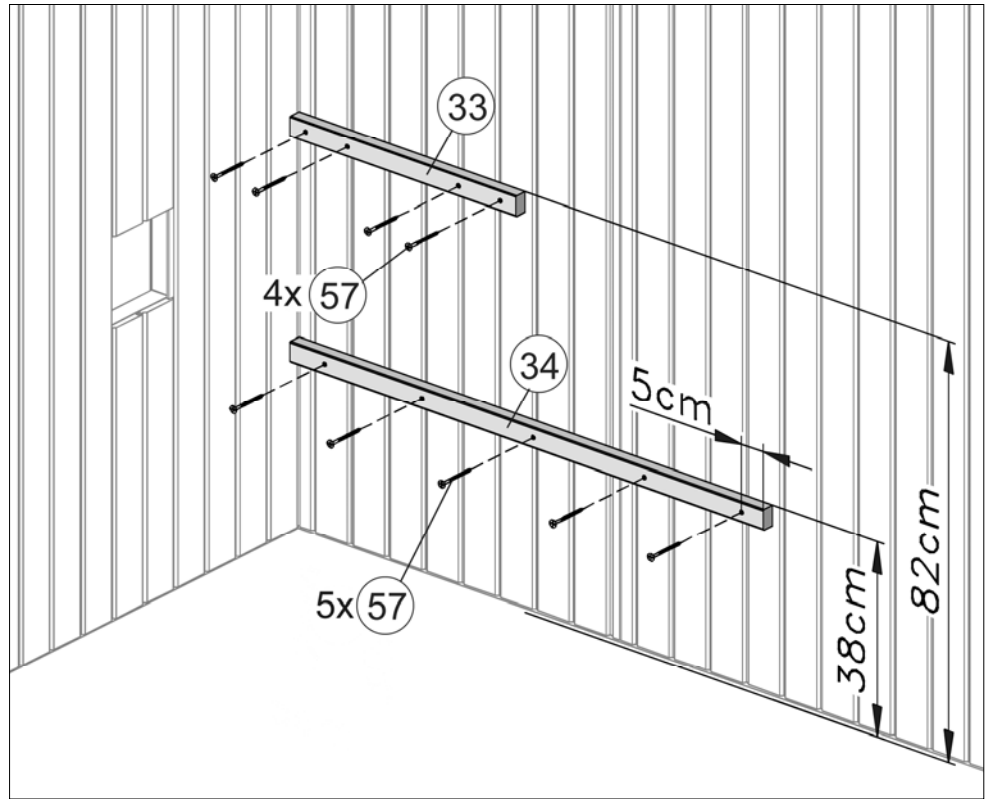

**12.2**

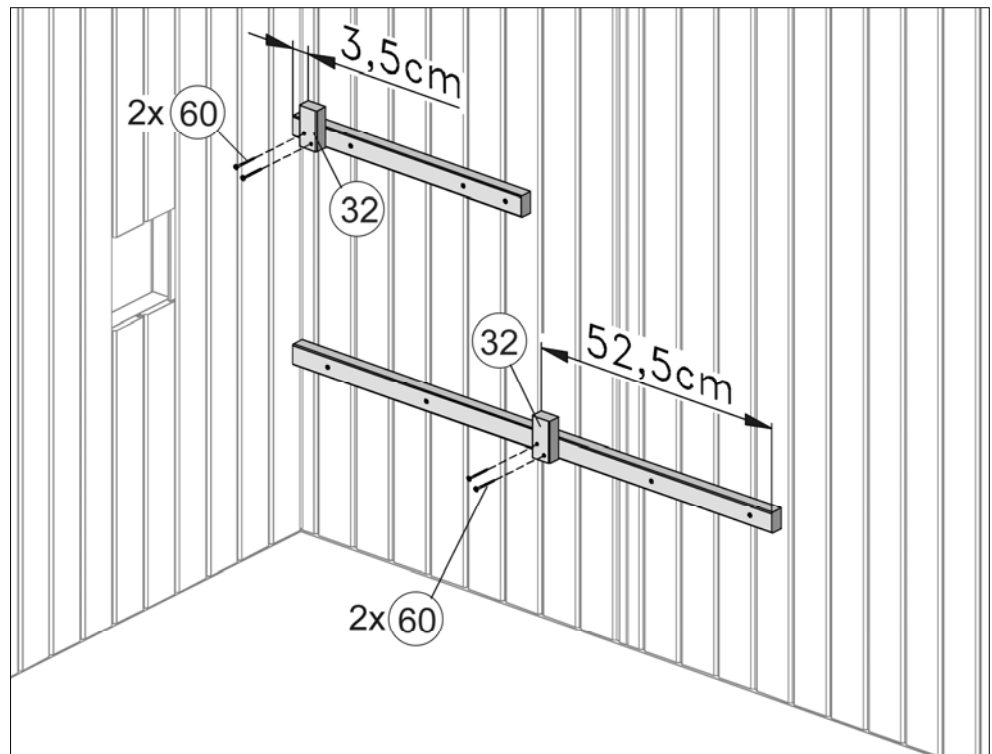

13

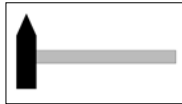

↑ A

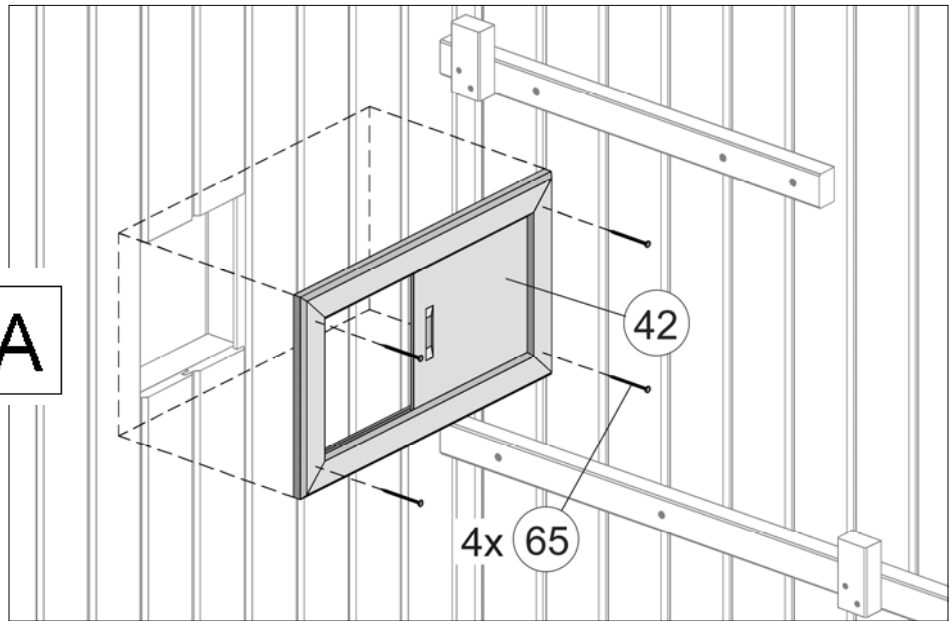

14

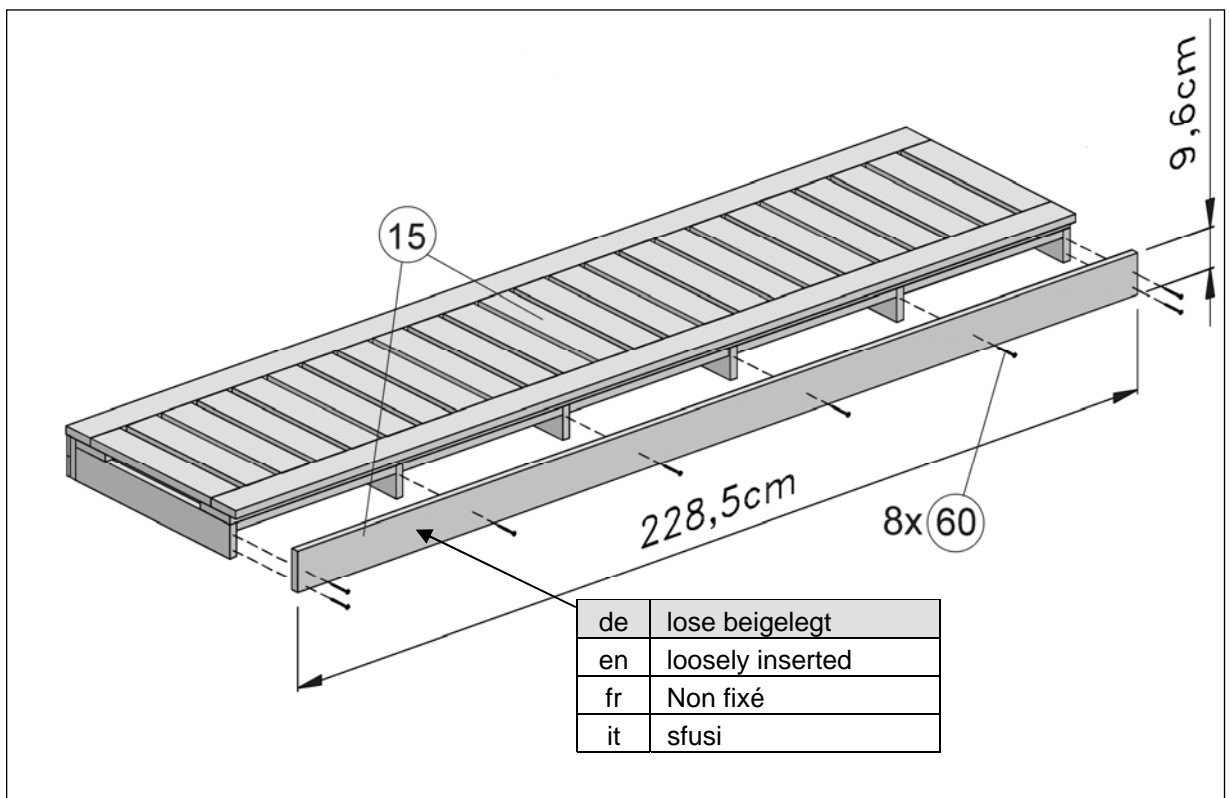
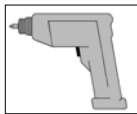

16

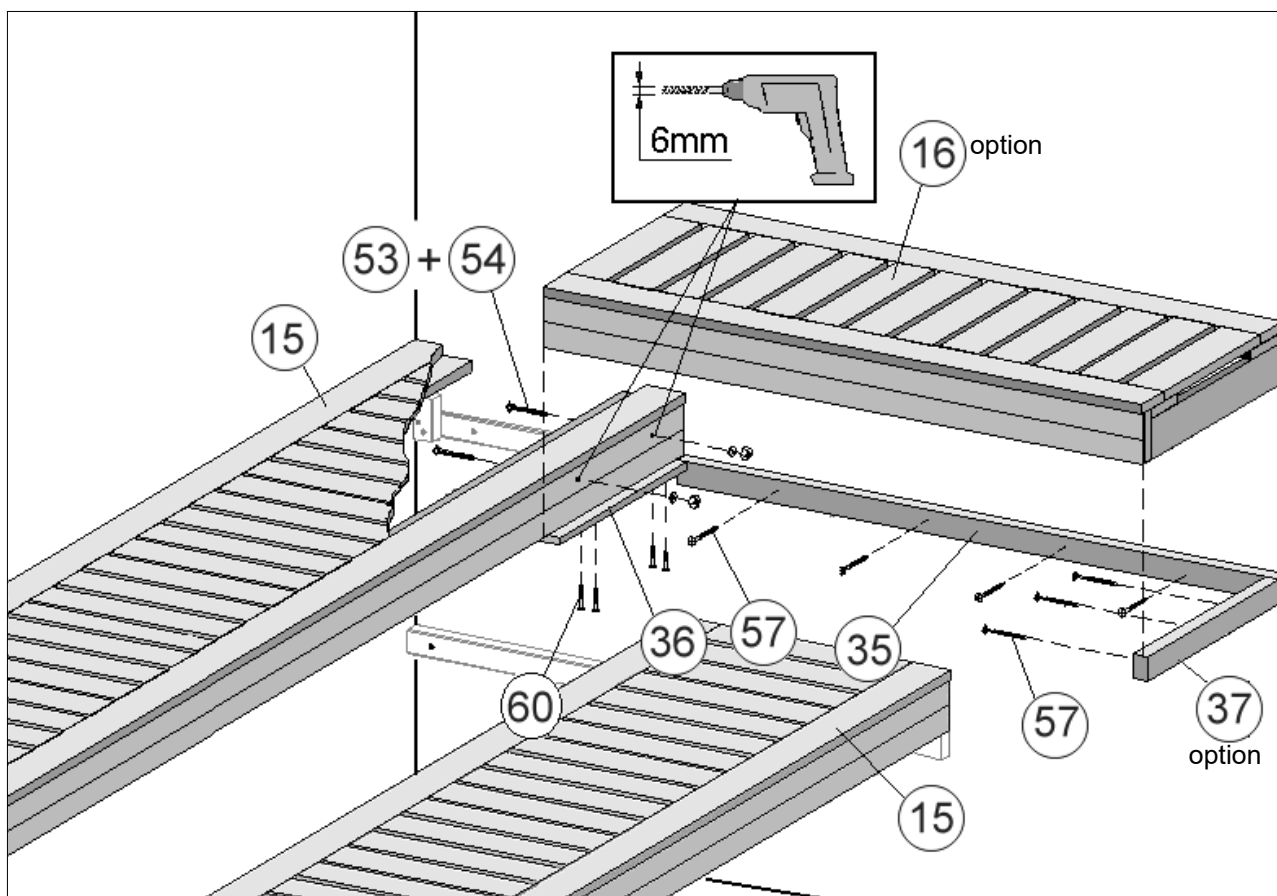
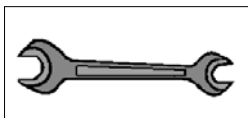
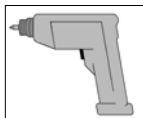
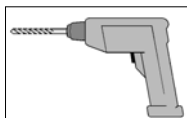

17

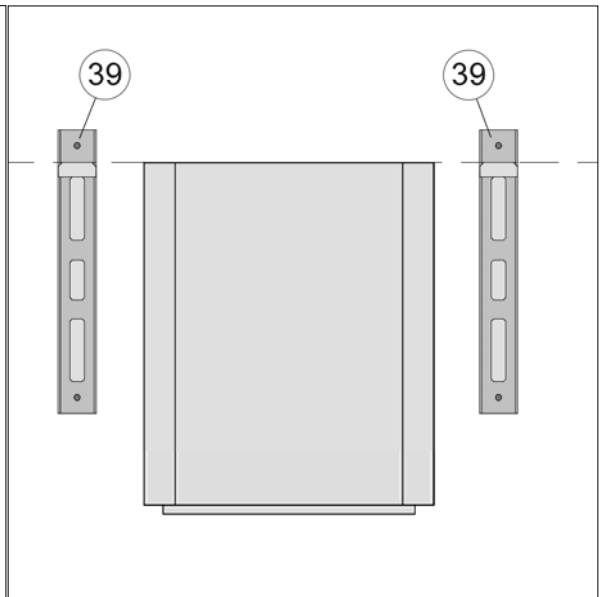
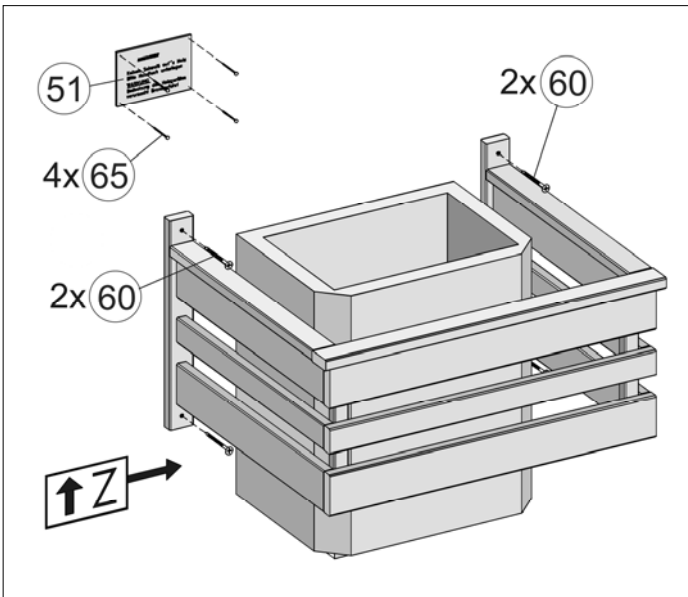
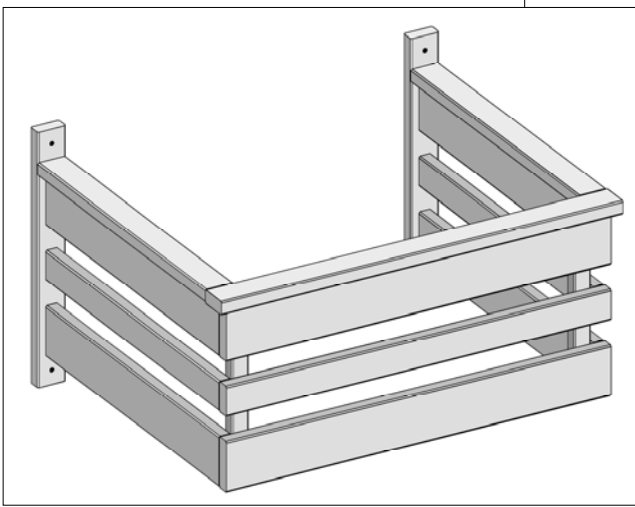
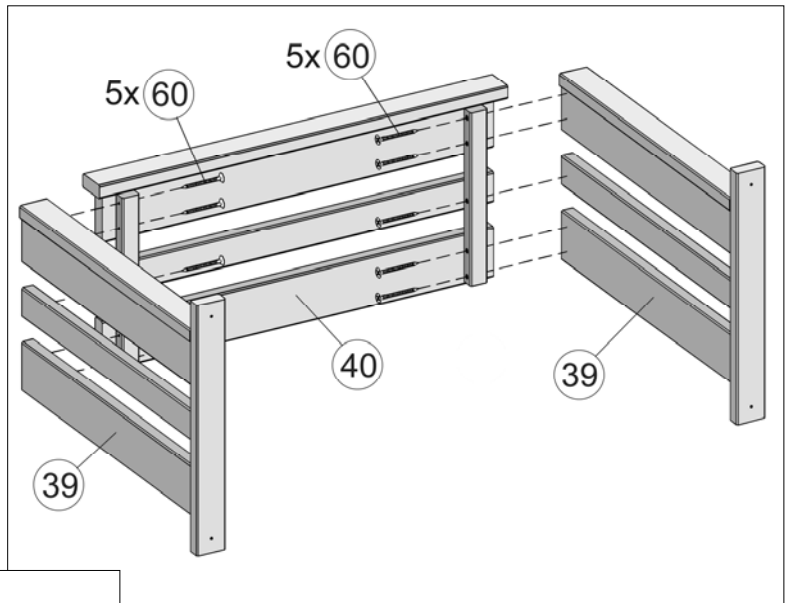
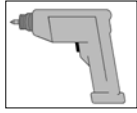
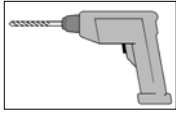

18

