

EDGESTAR[®]

Portable Air Conditioner

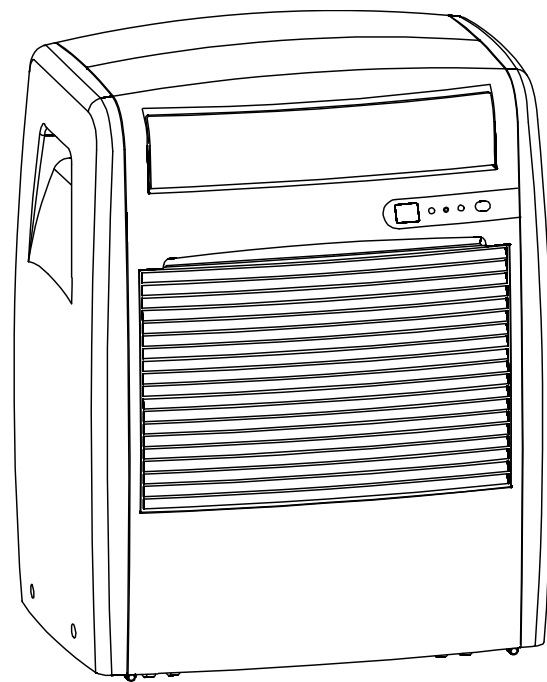

AP8000W

Owner's Manual

For more information on other great EdgeStar products on the web, go to <http://www.edgestar.com>

Important Safety Information

Improper handling can cause serious damage to the appliance and/or to the user. Please read the following safety information.

Electrical Safety

- This unit is designed for indoor use only.
- Do not use the unit in extremely humid or wet environments.
- Do not spray water and wet the housing or control panel.
- Do not pull the unit by the cord.
- Always turn the unit off and unplug it from the outlet when cleaning.
- Unplug the unit if it is not going to be used for a long period of time.
- Do not operate the unit with a damaged plug or a loose socket.
- Use only the correct power supply with appropriate amperage.
- If the power cord is damaged, it must be replaced by the manufacturer, a service agent, or qualified technician.
- Do not remove any part of the casing unless instructed by an authorized technician.

General Safety

- This portable air conditioner is not intended to be used by children.
- Children should be supervised to ensure that they do not play with this product.
- Do not allow children to play with the controls or drop any objects into the air outlets or vents.
- Do not place objects or let any person sit on top of the unit.
- Only use in the upright position on a flat, level surface and provide at least 20 inches of clearance from any walls or objects.
- Route the power cord carefully to avoid a tripping hazard.
- This unit is intended for domestic use only. Do not use the portable air conditioner for industrial or commercial use. Any other use may invalidate the warranty.

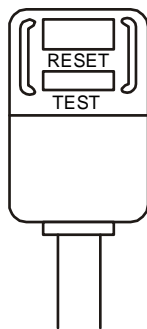

Your portable air conditioner is supplied with a Leakage-Current Detection and Interruption (LCDI) safety plug. This device provides protection to reduce the risk of fire due to arcing faults in the power supply cord. Before using your portable air conditioner, follow the instructions below to ensure that the LCDI plug is working properly:

1. Plug the power cord to a grounded outlet.
2. Press the TEST button on the LCDI plug. This should trip the plug and cut the power to the air conditioner. If the plug does not trip and you are able to turn on the unit, please contact EdgeStar support.

DO NOT USE YOUR PORTABLE AIR CONDITIONER IF THE TEST FAILS.

Press the RESET button to start using your air conditioner.

Do not use the TEST and RESET buttons as an ON/OFF switch.

Electrical products should not be disposed of with household waste. Please contact your local recycling center for more information on how to recycle electronic waste.



Table of Contents

IMPORTANT SAFETY INFORMATION	1
INTRODUCTION	1
PARTS IDENTIFICATION	2
BACK VIEW	2
FRONT VIEW	2
INSTALLING THE CARBON FILTER	3
WINDOW KIT INSTALLATION INSTRUCTIONS	4
PREPARATIONS FOR INSTALLING THE WINDOW KIT	4
INSTALLING THE GRATED ADAPTER	5
INSTALLING THE WINDOW PLATES	6
ATTACHING THE DUCT CONNECTORS TO THE EXHAUST HOSE	7
CONNECTING THE DUCT CONNECTOR TO THE UNIT	8
CONNECTING THE DUCT CONNECTOR TO THE GRATED ADAPTER	8
NOTES ABOUT THE EXHAUST HOSE	9
CONTROL PANEL OVERVIEW	10
USING THE CONTROL PANEL	11
LCD DISPLAY	11
MODE INDICATOR LIGHT	11
POWER BUTTON	11
AUTO-RESTART:.....	11
WATER FULL LIGHT.....	11
REMOTE CONTROL SENSOR.....	11
REMOTE CONTROL OVERVIEW	12
INSTALLING THE BATTERIES.....	12
REPLACING THE BATTERIES	12
OPERATING THE REMOTE CONTROL	13
POWER	13
AUTO-RESTART:.....	13
COOLING MODE.....	13
DEHUMIDIFYING MODE.....	13
FAN ONLY MODE	14
SPEED	14
TIMER.....	14
<i>How to set the unit to automatically turn on</i>	14
<i>How to set the unit to automatically turn off</i>	14
SETTING THE TEMPERATURE	14
FAHRENHEIT / CELSIUS.....	14
ENERGY SAVING GUIDE	15
MAINTENANCE	16
CLEANING THE UNIT	16
CLEANING THE PRE-FILTER	16
PREPARATION FOR STORAGE	16
TROUBLESHOOTING	17
TROUBLESHOOTING CONTINUED	18
SPECIFICATIONS	19

Introduction

Thank you for purchasing this EdgeStar portable air conditioner. We are glad you chose us. We believe that your purchase of this product opens a relationship between you and EdgeStar. We will provide the customer support needed to nurture that relationship.

This manual contains important information regarding the proper installation, use and maintenance of your portable air conditioner. Following this manual will ensure that your product will work at its peak performance and efficiency.

Please save the original product packaging in case you need to safely transport your portable air conditioner.

For Your Records:

Please write down the model number and serial number below for future reference. Both numbers are located on the ratings label on the back of your unit and are needed to obtain warranty service. You may also want to staple your receipt to this manual as it is the proof of your purchase, and is also needed for service under your warranty.

Model Number: _____

Serial Number: _____

Date of Purchase: _____

To better serve you, please do the following before contacting customer service:

- If you received a damaged product, immediately contact the dealer that sold you the product.
- Read and follow this instruction manual carefully to help you install, use and maintain your portable air conditioner.
- Read the troubleshooting section of this manual as it will help you diagnose and solve common issues.
- Visit us on the web at <http://www.edgestar.com> to register your product, download product guides, additional troubleshooting resources and up-to-date information.
- If you need warranty service, our friendly customer service representatives are available via email at service@edgestar.com or by telephone at **1 (866) 319-5473**.

Parts Identification

Front View

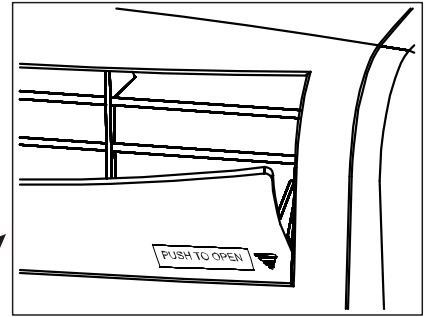

Front Air Vent

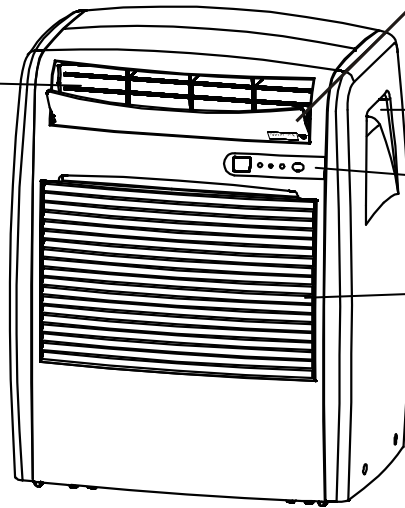

Handle

Front Control Panel

Front Grille / Air Intake

Note: You must open the front air vent when operating the unit. The unit is designed to blow air mostly from the right side.

Back View

Exhaust

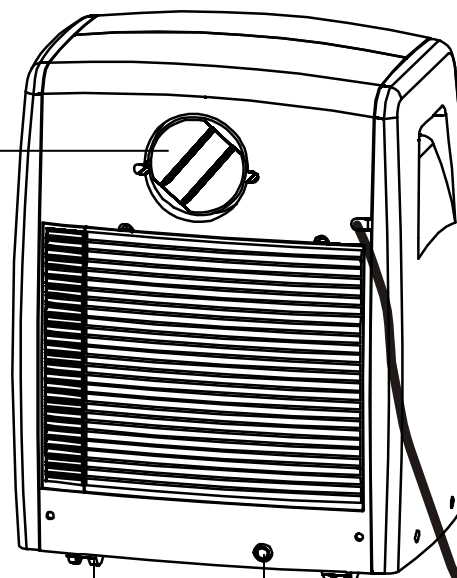

Power Cord

Caster

Drain

Installing the Carbon Filter

Your portable air conditioner ships with a pre-filter and an activated carbon filter. The carbon filter will help remove contaminants and odors from the air. It is recommended you replace the carbon filter every two to three months, or as needed. It is necessary to clean the pre-filter periodically. Follow the steps below to install the carbon filter:

CAUTION: Never operate the air conditioner without the pre-filter attached.

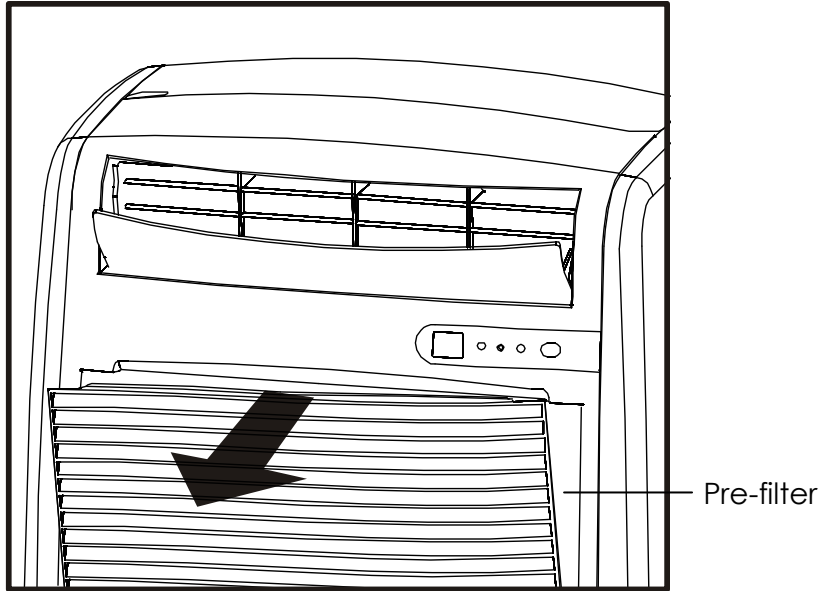

1. Shut off the unit if it is on. Pull the front grille forward.

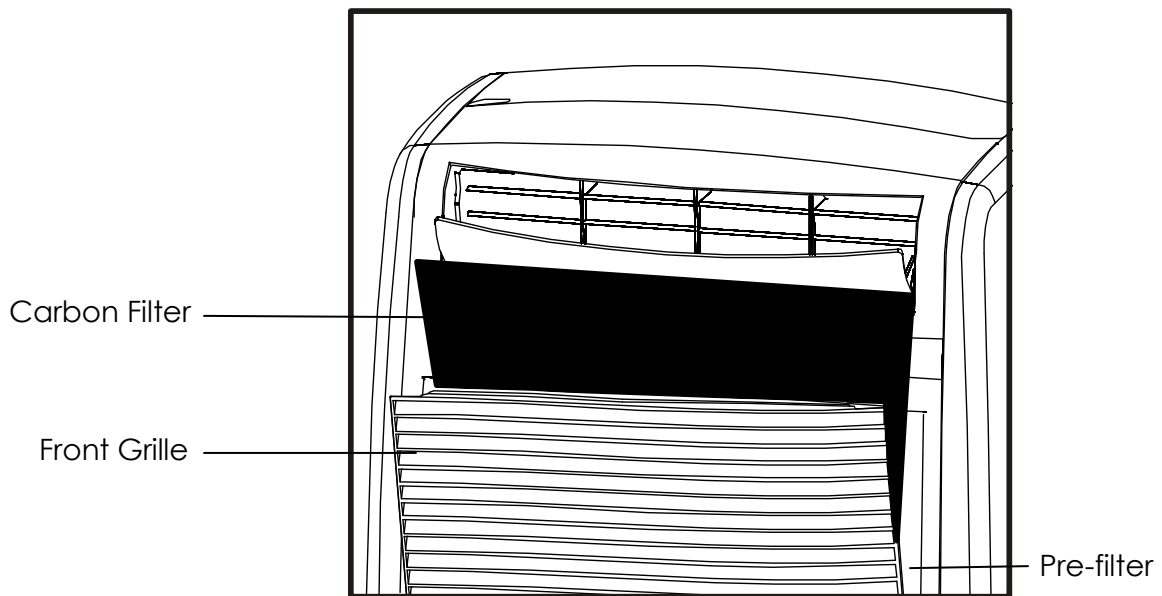

2. Place the carbon filter between the grille and the pre-filter.
3. Close the grille.

Window Kit Installation Instructions

Preparations for installing the window kit

You must vent your portable air conditioner when running in its cooling mode. Your unit includes a window exhaust kit that can be used to vent the unit out a window.

Before you begin, make sure you have all the parts necessary for installation.

Window Kit Parts List:

NOTE: Exhaust Covers may be attached to the Grated Adapters. You may need to twist and pull apart to separate them.

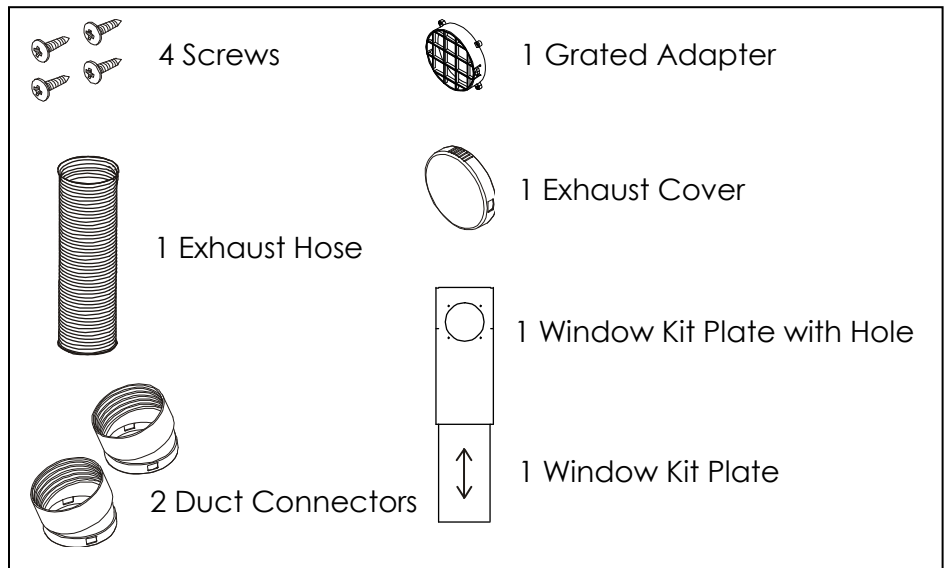

NOTE: You may need to contact your electrician if your room's circuit is not able to power your unit.

If you have multiple windows, choose one that is near an electrical outlet that will be able to provide sufficient power to your unit. See the power requirements listed on the product label printed on the side, or on the back of your portable air conditioner.

Your window kit can be installed on a horizontal or vertical sliding window as shown in the following pictures:

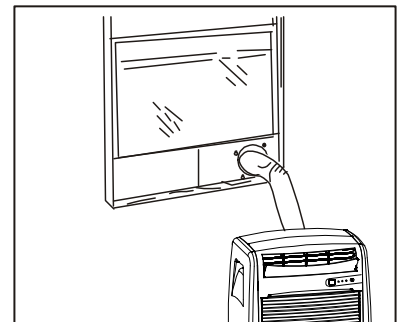
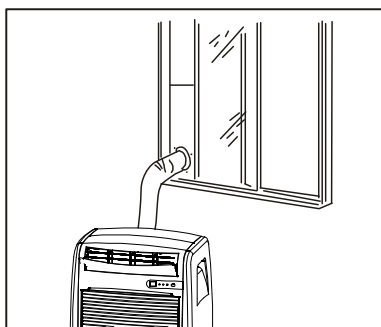

Follow the instructions on the next pages to install the window kit.

**Installing the grated
adapter**

1

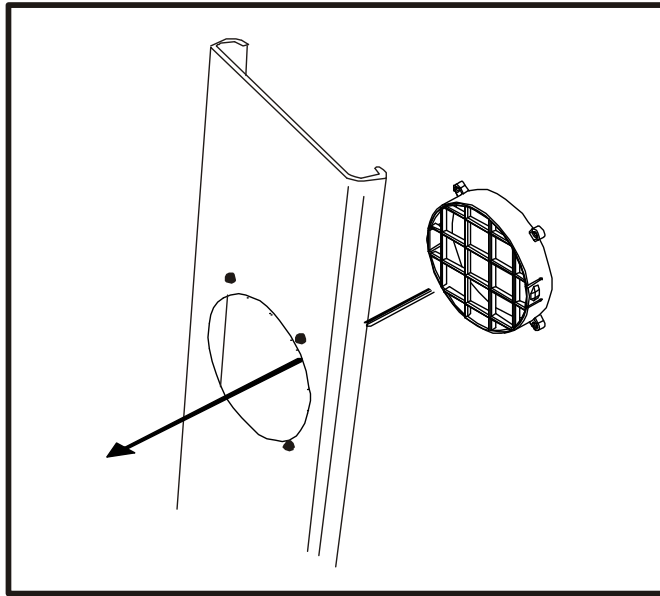

1. Insert the round grated adapter through the back grooved side of the window kit plate with hole.

2

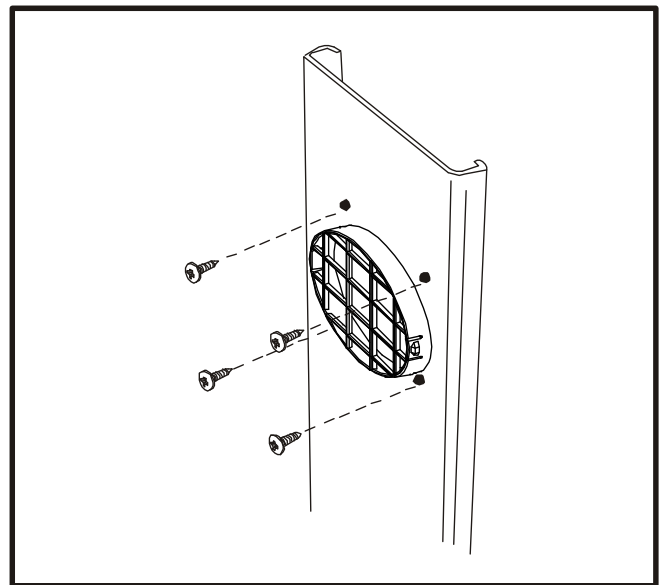

2. Secure the grated adapter by fastening the screws from flat side of the window kit plate to the holes on the grated adapter.

Installing the window plates

3

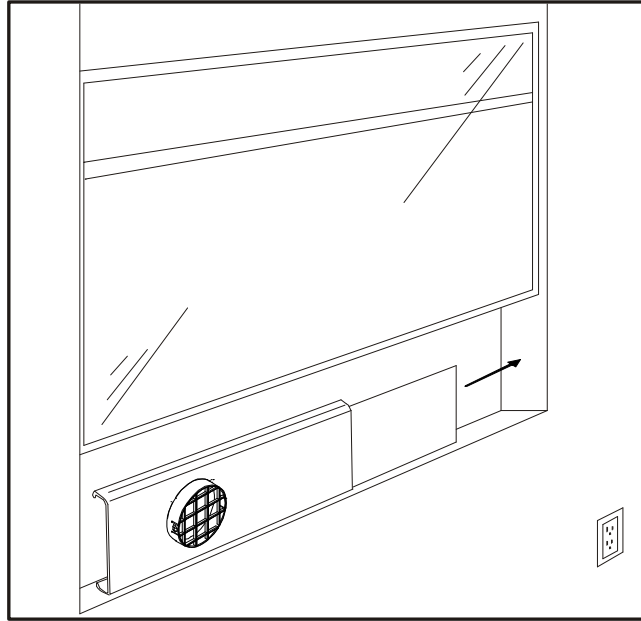

3. Open your window and place the window kit with grooved side facing outward on the window sill. Then, slide the window kit plate to fit the width of the window. You can use screws to secure the window kit plate from sliding.

CAUTION: Secure your window by using window locks. Please contact your dealer to purchase window locks.

4

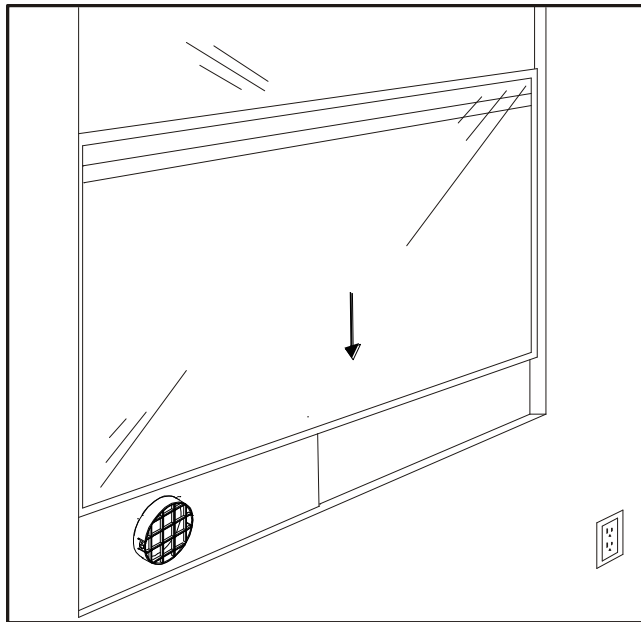

4. Lower the window to secure the window kit in place. You may need to use duct tape to better secure the window kit.

Attaching the duct connectors to the exhaust hose

⑤

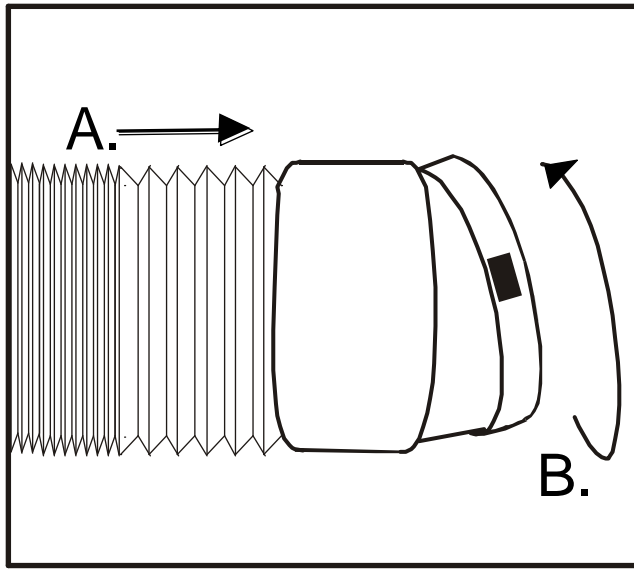

5. Attach the connectors to the hose:
A. Extend the ends of the exhaust hose
B. Thread the duct connector on by turning it clockwise until it stops.

⑥

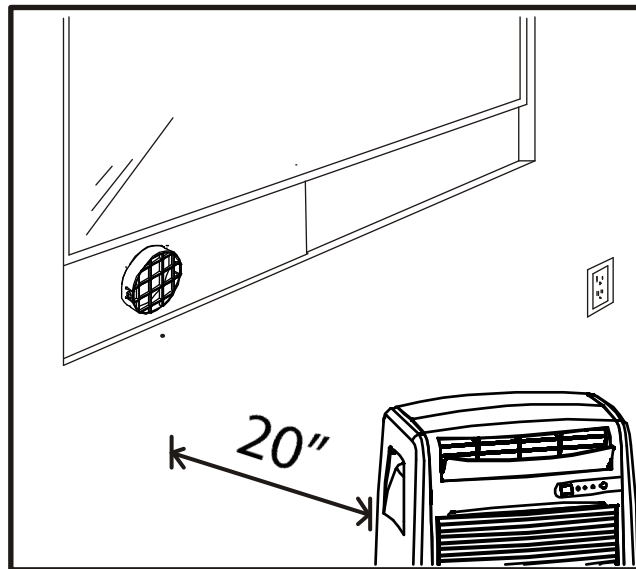

6. Roll the unit towards the window kit. Leave a space that is at least 20 inches to the wall.

Connecting the duct connector to the unit

7

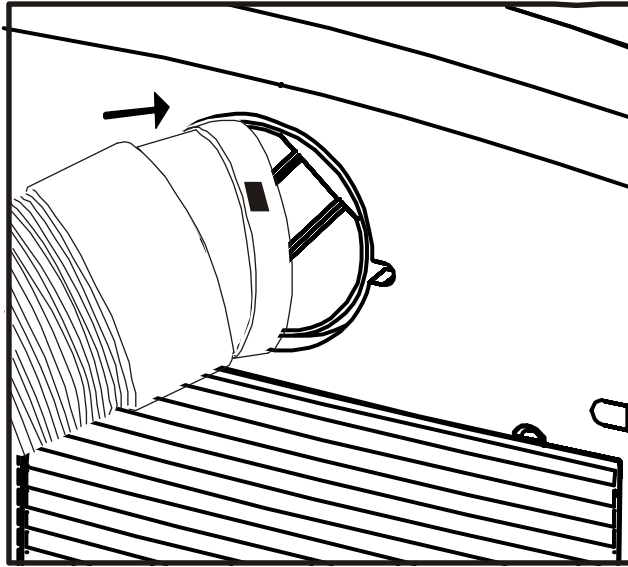

7. Align the slots on the duct connector to the tabs and snap into the back of the unit.

Connecting the duct connector to the grated adapter

8

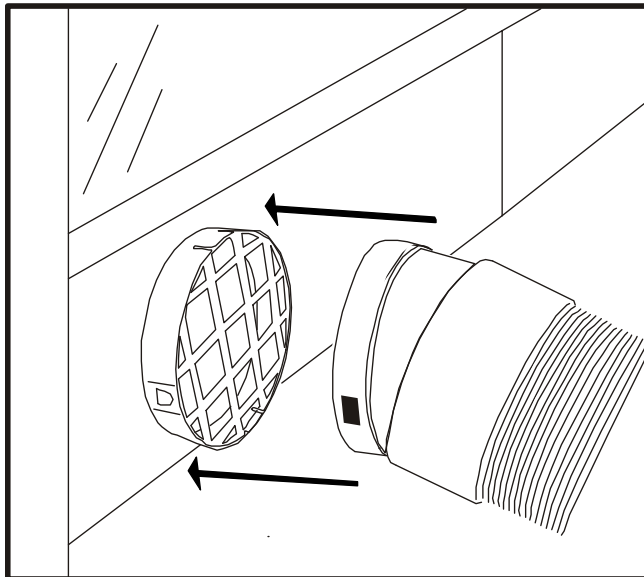

8. Align the slots on the duct connector to the tabs on the grated adapter and snap in place.

Notes about the Exhaust hose

After you have installed the exhaust hose and window kit, you can plug in your portable air conditioner and start using it.

Your portable air conditioner is designed to exhaust condensate water that is collected from the air. This water, in either gaseous or droplet form, will be expelled out the exhaust port of the unit. Please take this into account when deciding how to vent it.

1. The exhaust hose supplied with the portable air conditioner can be extended up to 48 inches; however for maximum efficiency, use the shortest length possible.

2. Try to prevent any kinks or bends in the exhaust hose. Kinks or bends may trap exhaust air which can radiate heat into the room or potentially cause the portable air conditioner to overheat and shut itself off.

3. The exhaust hose supplied with the portable air conditioner has been specifically designed for this air conditioner. Do not lengthen the hose by adding additional hoses or attachments or replace it with any other hose.

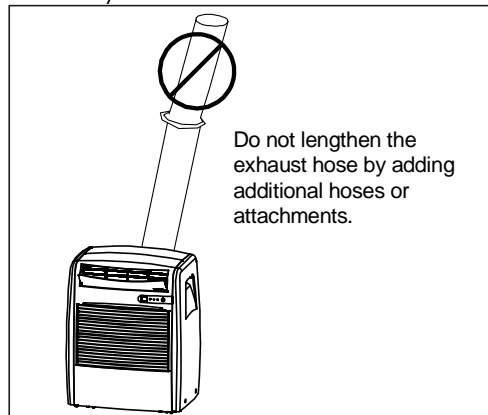

Warning: Longer hoses are not recommended.

Draining the Unit

When the portable air conditioner is in cooling mode, or dehumidify mode, it will remove moisture from the air. The condensed water from the air will be collected in an internal reservoir and will be evaporated and exhausted out of the exhaust hose. However, in very humid conditions, the internal reservoir may fill completely. This causes the air conditioner to turn off to avoid overflowing the internal reservoir. The WATER indicator will light up on the Control Panel.

Direct drainage

1. Remove the rubber drain plug from the drain port.
2. Connect a drain hose to the drain port.

The portable air conditioner will now drain through the drain hose. Please note that this unit has no drain pump; all water will drain with gravity only, i.e., only "downhill."

Control Panel Overview

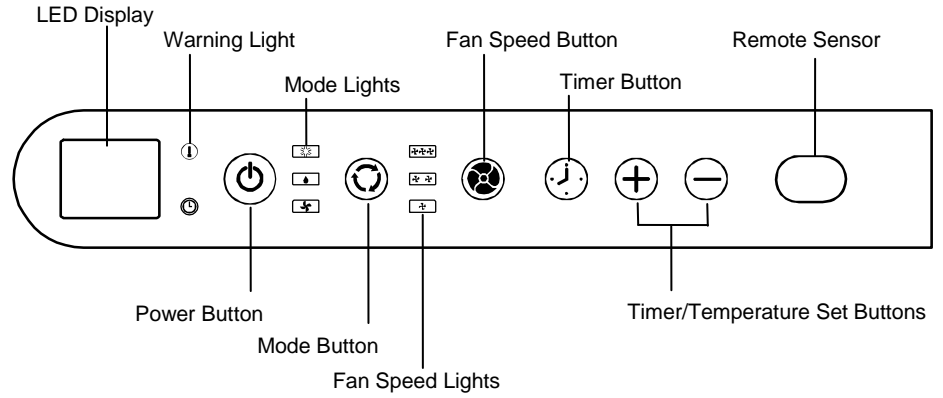

	Function
LED Display	The LED can display the ambient temperature, set temperature, and the number of hours when setting the timer.
Mode Indicator Light	Changes color to indicate if unit is in: Cool mode (Blue Light), Dehumidify (Amber Light), or Fan Only mode (Green Light).
Power Button	Powers the unit on or off.
Water Indicator Light	The water light will turn on if the unit has filled the internal water reservoir.
Remote Control Sensor	Receiver for the remote control.

Note: Use the Remote Control to change modes, fan speed, timer, and temperature settings.

Using the Control Panel

LCD Display

The LCD Display will show the ambient temperature by default. Pressing the Up and Down buttons on the remote control will show the set temperature for 15 seconds, and then revert to the room temperature. You can switch between Fahrenheit and Celsius by pressing the C/F button on the remote control. The displayed range of the ambient temperature is from 0° to 99°. Temperatures above 99° will be displayed as “Hi”, and temperatures below 0° will be displayed as “Lo”. If you enabled the Timer, the LCD Display will show the hour(s) set.

Mode Indicator Light

The Mode indicator light on the control panel changes color to indicate the mode you selected with the remote control:

- Blue light: The unit is in cooling mode.
 - Amber light: The unit is in dehumidifying mode.
 - Green light: The unit is in fan mode.
-

Power Button

Use the Power button to turn the portable air conditioner on and off.

By default when you first use the power button, the unit will begin to operate in cooling mode. The unit will remember the last used mode/settings if you shut down and restart.

Auto-Restart: If power to the unit is interrupted, the air conditioner will restart itself in its last used mode/settings once power is restored. The compressor will restart after 3 minutes.

Water Full Light

In high humidity situations, the internal water reservoir may fill. The unit will automatically shut off and the water light will turn on. Once the water is manually drained, the unit will operate normally.

Remote Control Sensor

The remote control sensor receives infrared signals given by the remote control.

Remote Control Overview

The remote control is used to operate all of your portable air conditioner's functions.

NOTE: Be careful not drop the remote control. Do not place the remote control in a location exposed to direct sunlight.

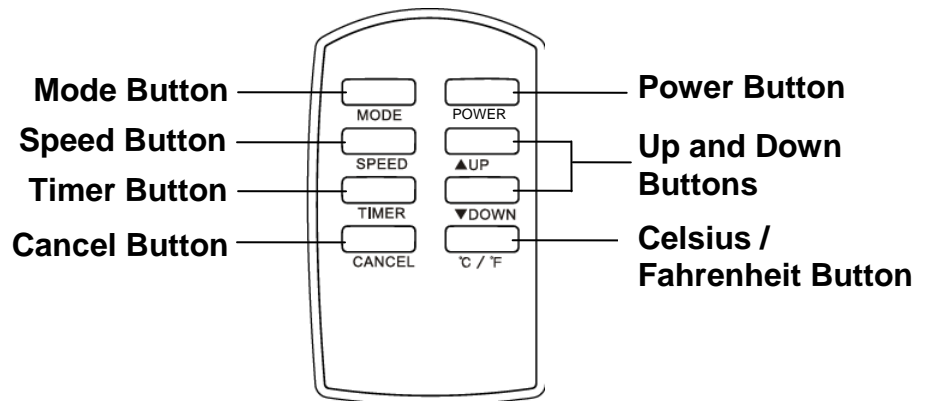

Button	Function
Power	Powers the unit on or off.
Mode	Changes between cool, dehumidify and fan modes.
Speed	Sets the fan speed between high, medium, or low.
Timer	Used to enable the timer.
Cancel	Used to cancel the timer.
□ Up	Increases the set temperature or the time when the Timer is enabled.
□ Down	Decreases the set temperature or time when the Timer is enabled.
°C / °F	Changes the displayed temperature between Celsius and Fahrenheit.

Installing the batteries

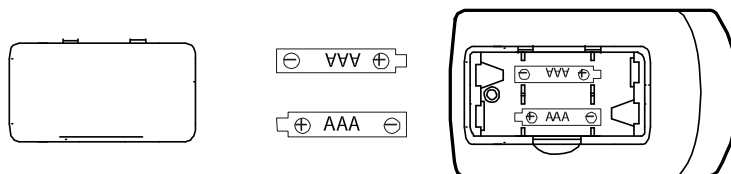

- 1) Remove the cover on the back of the remote control.
- 2) Insert the batteries with the (+) and (-) ends pointing in the correct direction.
- 3) Install the cover on the remote.

CAUTION: Use only AAA batteries. Remove the batteries if the remote control will not be used for one month or longer. Do not attempt to recharge batteries not designed to be recharged. All batteries should be replaced at the same time. Do not mix old and new batteries. Do not dispose of batteries in a fire as they may explode.

Operating the Remote Control

Power

Use the Power button to turn the portable air conditioner on and off.

By default when you first use the power button, the unit will begin to operate in cooling mode. The unit will remember the last used mode/settings if you shut down and restart.

Auto-Restart: If power to the unit is interrupted, the air conditioner will restart itself in its last used mode/settings once power is restored. The compressor will restart after 3 minutes.

Cooling Mode

Cooling mode cools and dehumidifies the air. If the ambient temperature drops below the temperature you selected, the compressor turns off and the unit functions with the fan only. When the temperature rises above the temperature you selected, the compressor turns on again.

Whether your desired temperature can actually be reached depends on the ambient conditions. The room temperature remaining above the set temperature is normal.

NOTE: The exhaust hose must be used in Cooling mode in order to cool a room.

To operate the unit in cooling mode:

- 1) Make sure the power cord is plugged into a power outlet.
- 2) Press the Power button on the remote.
- 3) Press the Mode button until the Mode Indicator Light on the Control Panel turns blue.
- 4) Select the fan speed by using the Speed button.
- 5) Set the thermostat by using the Up and Down buttons. The thermostat is adjustable between 61°F - 89°F in one degree increments. You can switch between Fahrenheit and Celsius by pressing the °C / °F Button

Dehumidifying Mode

During the Dehumidifying mode, the unit will condense water out of the air and exhaust it through the exhaust hose. The ambient temperature in the room will probably drop by a few degrees while using the Dehumidifying mode.

To operate the unit in dehumidifying mode:

- 1) Make sure the power cord is plugged into a power outlet.
- 2) Press the Power button on the remote.
- 3) Press the Mode button until the Mode indicator light turns amber on the Control Panel.

NOTES: If the room temperature is below 77°F, the fan will always run on low speed while in the Dehumidifying mode. If you do not use the exhaust hose in Dehumidifying mode, you must manually drain the water from the unit. Additionally, the ambient temperature in the room will probably rise by a few degrees if you do not use the exhaust hose. You will be not be able to change the thermostat temperature or fan speed while in Dehumidifying Mode.

Operating the Remote continued

Fan Only Mode

Fan Only mode is used to circulate the air in your room. No temperature setting is needed.

To operate the unit in Fan Only mode:

NOTE: Fan Only mode does not require that the exhaust hose be attached.

- 1) Make sure the power cord is plugged into a power outlet.
- 2) Press the Power button on the remote.
- 3) Press the Mode button until the Mode indicator light turns green.
- 4) Press the Speed button to select the fan speed. You can choose between High, Medium and Low. The LED indicator next to the speed will light up.

Speed

The Speed button is used to change the fan speed while in Cooling and Fan Only modes.

Press the Speed button to select the fan speed.

Timer

The timer can be used to either turn the unit on or off after a number of elapsed hours. The timer is adjustable between 1-24 hours in one hour increments.

How to set the unit to automatically turn on:

- 1) Press the Timer button on the remote control while the unit is powered off.
- 2) Use the Up and Down buttons on the remote to set the time (displayed in hours) you want to pass before the unit turns on. After the selected time passes, the unit will automatically turn on.

NOTE: To cancel the timer, press the Cancel button or Power button.

How to set the unit to automatically turn off:

- 1) Press the Timer button on the remote control while the unit is powered on. The Timer indicator LED will light up
- 2) Use the Up and Down buttons on the remote to set the time (displayed in hours). The unit will automatically turn off after the selected time elapses.

Setting the Temperature

To set the temperature in cooling mode, use the Up and Down buttons on the remote. The temperature range is adjustable between 61°F - 89°F in one degree increments.

Fahrenheit / Celsius

You can switch the temperature to be displayed in Fahrenheit or Celsius by pressing the °C / °F Button.

Note: Default setting is in °F.

Energy Saving Guide

Read and follow the guide below to get the best performance and efficiency from your portable air conditioner:

- Do not cover the air outlet (exhaust) while in use.
- Do not place the unit in front of curtains or drapes- to ensure they do not obstruct the air intake.
- Minimize the length of the exhaust hose.
- Make sure the exhaust hose is as straight as possible and avoid kinks or bends.
- Keep curtains, blinds or drapes closed during the sunniest part of the day.
- Use the timer to operate the unit before it is needed. For example, set the timer to turn on the unit in cooling mode for 3 or more hours to cool the room before you arrive. You may want to operate the unit all day if you live in a warmer climate.
- Minimize the heat sources (direct sunlight, computers, servers, people, etc.) in the room.
- Close all windows and doors.
- Use the unit in a contained room. For example, a room with four walls and a ceiling, instead of a partitioned studio, or warehouse.
- Make sure the unit is on a level surface.
- Minimize the amount of humidity in the room. For example, run the unit as a dehumidifier.
- To prolong the compressor's life, please wait at least 3 minutes before turning the unit back on after shutting it off.
- Inspect and keep the pre-filters clean by cleaning regularly.
- Inspect and replace the activated carbon filters regularly.
- Perform routine maintenance.

Maintenance

Clean the air conditioner and filters regularly to maximize performance and efficiency, and prolong the unit's life. Be sure to always unplug the air conditioner from the power outlet before cleaning.

Cleaning the unit

Use a soft dry cloth to wipe the body clean. If necessary, use lukewarm water to dampen a cloth to clean the unit.
Use a soft bristle brush to clean between the vents.
Carefully use a vacuum cleaner to clean the condenser coils.

Never use abrasive chemicals, volatile substances, gasoline, detergents, chemically treated cloths, or other cleaning solvents that may damage the cabinet exterior.

Never spray water directly on the unit.

Cleaning the pre-filter

To clean the pre-filter, follow the steps below:

- 1) Power off the unit and remove the pre-filter.
- 2) Remove the activated carbon filter.
- 3) Use a vacuum cleaner or tap the filter lightly to remove loose dust and dirt, then rinse thoroughly under lukewarm running water (below 104°F). You may use a mild soap and water solution if needed. Allow the pre-filter to air dry in a cool and shaded place. Dry thoroughly before reinstalling.

NOTE: The activated carbon filter is not washable. You should replace it every 2-3 months or as needed. Contact EdgeStar retailers for replacement filters.

Clean the pre-filter periodically. If the unit is used in a dusty environment you may need to clean it on a weekly basis.

Warning: Never operate the unit without the pre-filter.

Preparation for Storage

If you are not going to be using the unit for an extended period of time, follow the instructions below before storing your unit:

- 1) Drain all the water from the unit's reservoir. Operate the unit in fan mode for a few hours to thoroughly dry any moisture left on the coils inside the unit.
- 2) Power off the unit, and clean or change the filters.
- 3) Unplug and carefully wind the power cord.
- 4) Remove the exhaust hose and duct connectors and keep them in a safe place.

Troubleshooting

Follow the troubleshooting guide below to resolve common issues.

Issue	Possible Cause	Solution
My air conditioner is not functioning at all.	Unit is not receiving power.	Make sure the unit is plugged in to a grounded outlet.
	LCDI power cord is tripped.	Press the Reset button on the LCDI cord.
	Insufficient power.	Move the unit to another outlet. Check your circuit breaker. (Refer to the rating label on the back of the unit to determine the Amperage draw).
	Water reservoir is full.	Drain the unit and restart.
	Control panel is disconnected.	If no indicator lights turn on, contact customer service.
My remote control does not work and the indicator light on remote does not turn on.	Batteries not installed.	Install new batteries.
	Bad batteries.	Replace the batteries.
	Batteries installed incorrectly.	Reinstall the batteries correctly.
	A defective remote control.	Contact customer service.
My air conditioner is making a loud noise.	The unit is not level.	Make sure the unit is on a level surface.
	A foreign object has jammed the fan.	Remove the object from the fan.
	The floor below the unit is uneven.	Move the unit to a level surface.
My air conditioner is making a continuous metallic knocking or pinging sound.	Unit may have been shipped on its side.	Shut off the unit. Let the unit sit on a level surface for at least 24 hours and restart.
	Damaged compressor.	Contact customer service.
My air conditioner is leaking.	Drain plug is removed.	Attach the drain plug.
	Cracked base pan.	Contact customer service.
My air conditioner runs for a little while and then it trips the power cord or the circuit breaker.	The air conditioner may be plugged into an outlet that can not supply the correct amount of current.	Contact an electrician if the unit works in a different room or circuit.
The control panel lights blink randomly.	Unit may have a faulty control panel.	Contact customer service.
No air comes out the left side of the air vent.	The unit is designed to blow air from the right.	This is normal operation.

Troubleshooting continued

Issue	Possible Cause	Solution
My air conditioner is not cooling at all.	Unit is not operating in cooling mode.	Set the unit to be in cooling mode, and lower the set temperature (pg. 13).
	The compressor is not on.	The compressor may take up to 3 minutes to turn on, or longer if it is too warm.
	The ambient temperature is too high.	Lower the room temperature to be below 90°F degrees.
	The filter may be dusty or blocked.	Clean the filters. (pg. 16)
	Blocked exhaust port.	Remove any obstructions in the exhaust hose and port.
My air conditioner blows cold air, but does not lower the room temperature.	The unit is not vented.	The unit must be vented. (pg. 4)
	The area of the room is too large.	Minimize the size of the area to be cooled, i.e. adding a drop ceiling. Use more than one unit to cool the area, or use a larger unit.
	Open windows and doors.	Close any open doors and windows.
	Too many heat sources.	Remove or shut off additional heat sources such as radio equipment, servers, etc.
	The room/garage may be inadequately insulated.	Properly insulate the room to be cooled, i.e. using fiberglass.
	The ambient temperature is too high.	The unit may not work if the room temperature is above 90°F.
	Direct sunlight is heating the room.	Close curtains or pull down blinds, and minimize the direct sunlight into the room.
	The filter may be dusty or blocked.	Clean the filter and replace it if needed.
	Dirty condenser coils.	Carefully vacuum the coils clean.
Obstructed air intake or exhaust ports.	Remove anything blocking the ports.	

NOTE: If the ambient temperature is above 90°F the unit may not blow cold air.

TIP: Run the unit before it is needed. For example, run the unit in the morning before the area gets hot, and continue to run the unit all day long in order to maintain a low temperature.

Specifications

Description of product	Portable Air Conditioner
Model	AP8000W
Voltage/Frequency	AC 115V~60Hz
Input Power	840W
Current	7.9A
Color	White
Dehumidifying capacity	71 Pints/Day
Coolant	R-410A
Timer	24 Hour
Dimensions WxHxD	19 1/4" 24 3/4" x13 1/4"
Weight	56 lbs

EDGESTAR[®] Product Warranty

Warranty Period	EdgeStar will be responsible for:	Consumer will be responsible for:
1st year	All costs for repairing or replacing parts and/or unit which proves to be defective. All transportation costs in the first 90 days.	All transportation costs after 90 days.
Limited 2nd-3rd year (compressor only)	Repairing or replacing any compressor which proves to be defective. (Labor not included)	Labor and all transportation costs.

This product is warranted by EdgeStar and is subject to any conditions set forth as follows:

WHAT IS COVERED:

One Year Parts and Labor: For one year from the date of original retail purchase, EdgeStar will repair or replace any part free of charge including labor that fails due to a defect in materials or workmanship. EdgeStar will be responsible for all transportation costs for the first 90 days from original purchase date, after 90 days the consumer will be responsible. Labor will be performed free of charge at an authorized EdgeStar repair facility and EdgeStar will supply new, rebuilt, or refurbished parts free of charge. EdgeStar may request a defective part be returned in exchange for the replacement part. After the 12 month period, EdgeStar will no longer be responsible for labor charges incurred or replacement parts. All defective products and parts covered by this warranty will be repaired or replaced on a mail-in basis to an EdgeStar authorized repair facility.

Three Year Limited Warranty (Compressor- Labor Not Included): In the second through third year from the date of original retail purchase, EdgeStar will replace the compressor free of charge. The consumer will be responsible for all transportation and labor costs. EdgeStar will supply a new, rebuilt, or refurbished compressor and may request for the defective compressor to be returned in exchange. This limited 3-Year warranty is for the compressor only and does not include labor.

All warranties apply to the original purchaser only, and only covers defects in workmanship experienced during operation of the product under normal service, maintenance, and usage conditions. This warranty applies to the purchase and use of this product in residential settings within the United States of America. All products and parts replaced by EdgeStar under warranty service become the property of EdgeStar. All defective products and parts covered by this warranty will be repaired or replaced on a mail-in basis to an EdgeStar authorized repair facility.

Exceptions: Commercial or Rental Use Warranty: 90 days labor and parts from date of original purchase. No other warranty applies.

OBTAINING WARRANTY SERVICE: If you believe your product is defective, contact EdgeStar Customer Support for troubleshooting assistance and warranty service at www.edgestar.com or call 1-866-319-5473. Before contacting Customer Support you are required to have your model number, serial number and proof of purchase available upon request. Once an EdgeStar authorized representative has confirmed that your product is defective and eligible for warranty service, the product must be returned to an EdgeStar authorized repair facility. EdgeStar is not responsible for damage resulting from shipper mishandling or improper packaging. Do not return a defective product to the place of purchase. Products received without a return authorization number will be refused.

THIS WARRANTY IS IN LIEU OF ANY OTHER WARRANTY, EXPRESS OR IMPLIED, INCLUDING WITHOUT LIMITATION, ANY WARRANTY OF MERCHANTABILITY OR FITNESS FOR A PARTICULAR PURPOSE. TO THE EXTENT ANY IMPLIED WARRANTY IS REQUIRED BY LAW, IT IS LIMITED IN DURATION TO THE EXPRESS WARRANTY PERIOD ABOVE. NEITHER THE MANUFACTURER NOR ITS DISTRIBUTORS SHALL BE LIABLE FOR ANY INCIDENTAL, CONSEQUENTIAL, INDIRECT, SPECIAL, OR PUNITIVE DAMAGES OF ANY NATURE, INCLUDING WITHOUT LIMITATION, LOST REVENUES OR PROFITS, OR ANY OTHER DAMAGE WHETHER BASED IN CONTRACT, TORT, OR OTHERWISE. SOME STATES DO NOT ALLOW THE EXCLUSION OF INCIDENTAL OR CONSEQUENTIAL DAMAGES, SO THE ABOVE EXCLUSION MAY NOT APPLY TO YOU. THIS WARRANTY GIVES YOU SPECIFIC LEGAL RIGHTS. YOU MAY HAVE OTHER RIGHTS THAT VARY FROM STATE TO STATE.

WHAT IS NOT COVERED- The following limitations apply to the coverage of this warranty. This warranty does not cover:

Labor charges for installation, setup or training to use the product. Shipping damage, and any damage caused by improper packaging for shipment to an authorized service center, and any damaged caused by improper voltage or any other misuse, including abnormal service, handling, or usage. Cosmetic damage such as scratches and dents. Normal wear and tear on parts or replacement of parts designed to be replaced, e.g. filters, cartridges, batteries. Service trips to deliver, pick-up, or repair, install the product, or to instruct in proper usage of the product. Damages or operating problems resulting from misuse, abuse, operation outside environmental specifications, uses contrary to instructions provided in the owner's manual, accidents, acts of God, vermin, fire, flood, improper installation, unauthorized service, maintenance negligence, unauthorized installation or modification, or commercial use. Labor, service transportation, and shipping charges for the removal and replacement of defective parts, beyond the initial 12 month period. Products that have been modified to perform outside of specifications without the prior written permission of EdgeStar. Products lost in shipment, or theft. Products sold AS IS or from an unauthorized reseller. Products that have had their serial numbers removed, defaced, or with serial numbers that have been invalidated. Damage from other than normal household use. Replacement or repair of household fuses, circuit breakers, wiring or plumbing. Damage to personal property from use of product. Damage from service other than from an authorized EdgeStar repair facility. Hoses, knobs, lint trays and all attachments, accessories and disposable parts. Any service charges not specifically identified as normal such as normal service area or hours. Any special or consequential damages arising out of the use of the product.

EDGESTAR[®]

EdgeStar Products
500 N. Capital of TX Hwy, Bldg 5
Austin, TX 78746

Toll Free: 1-866-319-5473
Web: <http://www.edgestar.com>
E-mail: service@edgestar.com

Register your product, download owner's manuals, access additional troubleshooting resources, and obtain more information on other great EdgeStar products on the web at: **<http://www.edgestar.com>**

Product contents and specifications may change without notice.

Copyright © 2014 Living Direct, Inc. All rights reserved.