



Models

- | | |
|-----------------|-----------------|
| AD1C51 | AD2C51 |
| AS1C51 | AS2C51 |
| AD1C5112 | AD2C5112 |
| AS1C5112 | AS2C5112 |
| AD1C71 | AD2C71 |
| AS1C71 | AS2C71 |
| AD1C7112 | AD2C7112 |
| AS1C7112 | AS2C7112 |
| AU1C7112 | AU2C7112 |



Circle the model of your cooler and record the serial number below.

Encierre con un círculo el modelo de su enfriador y escribe el número de serie abajo.

Serial #

Número De Série _____

Read Carefully All Of This Manual Before Installing The Unit

Lea Con Cuidado Todo Este Manual Antes De Instalar La Unidad

Table Of Contents

Safety Instructions1	Warranty.....5
Installation Instructions..... 2-3	Parts List (Down Discharge Units) 6-7
Electrical Wiring Diagram3	Parts List (Side Discharge Units)..... 8-9
Operation.....3-4	Parts List (Up Discharge Units)..... 10-11
Maintenance Section.....4	Specification Tables (<i>Tablas de Especificaciones</i>).....12
Troubleshooting5	<i>Instrucciones en Español</i> 12-16

Vea el Español en el interior.

Read And Save These Instructions

Safety Rules

1. Read instructions carefully.
2. Electrical hook up should be done by a qualified electrician, so that all electrical wiring will conform to your local standards.
3. Always **DISCONNECT POWER** and **UNPLUG** motor and pump inside the cooler before installing or performing any maintenance.
4. Motor and pump have a grounded, molded plug and an automatic thermal overload switch which will shut motor off when it overheats. The motor will restart automatically when it cools down.

⚠WARNING: To reduce the risk of fire or electric shock, do not use this fan with any “solid-state fan speed control device.”

Evaporative Cooling

Evaporative cooling is nature’s way of cooling. When air is moved over a wet surface, water is evaporated and heat is absorbed. When stepping out of swimming pool with the wind blowing, evaporative cooling makes you feel cool, even though the air may be warm.

This unit works on the same principle. Air is drawn across wet filter pads where the air is cooled by evaporation and then circulated throughout the building. It is this combination of cooled air and the movement of air over the skin which makes it feel cool.

Unlike refrigeration systems which recirculate the air, an evaporative cooler continually brings in fresh air while exhausting old air. You are completely replacing the air every 2 to 4 minutes by opening windows or doors or a combination of both. The air is always fresh, not stale, laden with smoke and odors as happens with refrigerated air conditioning.

Cooler Installation

⚠CAUTION: Make sure that the mounting surface is strong enough to support the operating weight of the cooler when in use. (For operating weight, see Specification Table.)

⚠CAUTION: Never start cooler until installation is complete and unit has been tested for rigidity.

⚠CAUTION: Do not screw or drill within 5 inches of the bottom of the wet module. You could puncture the reservoir.

⚠CAUTION: If the unit is supported with legs at each corner, the middle of the unit where the two sections join must be supported as well.

NOTE: For ease of installation you can separate the wet module from the blower module by removing the 4 bolts from the wet module side (Fig. 1). Remember to unplug the pump and drain pump before separating the modules.

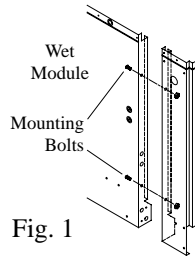

Fig. 1

Water Connection

• **Install overflow assembly.** Remove nut and place nipple through the hole in the pan, with the rubber washer between the pan and the head of the drain nipple (Fig. 2). Screw on nut and draw up tight against bottom of pan. Insert overflow into nipple to retain water. The overflow pipe comes from the factory connected to the dump pump hose. The overflow pipe may be removed to drain pan when necessary. A garden hose may be screwed on the drain nipple to drain water away from your unit.

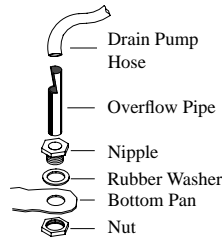

Fig. 2

• **Connect water supply line.** Install a sillcock and water valve on faucet as shown by figure 3. Place the nut and ferrule on the tubing and tighten the nut until water tight. **NOTE:** Do not connect the water supply to any soft water applications.

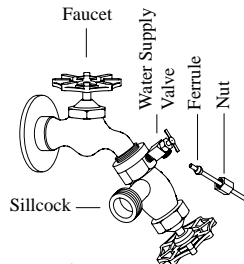

Fig. 3

• **Install float valve and fill pan.** Refer to Fig. 4. Remove items 1, 2, 3, and 4. Insert float body (5) through hole in back post panel as shown. Install washer (1) and nut (2). Tighten to keep float from turning. Place nut (4) and ferrule (3) on water supply line. Connect to float fitting and tighten until water tight. Bend rod (6) to adjust float until water level is about 1 inch below the top of the overflow pipe. Slide float shield (7) over float body (5) until it snaps into place.

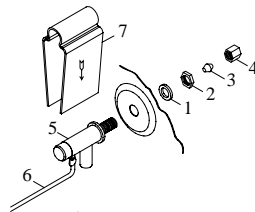

Fig. 4

Electrical Installation

⚠WARNING: Disconnect all electrical service that will be used for this unit before you begin the installation and leave it disconnected until the installation is complete.

The control box is factory wired and installed for either 120V or 230V operation depending on the model you purchased. The supply power

should be adequately protected against overloads and short circuits. **Note:** Electrical installation should be performed by a qualified electrician. Be sure to follow all National and Local Electrical Codes when installing this cooler.

• **Install weatherproof switch box.** Located inside the unit in a plastic bag is a switch box and cover, a chase nipple, a seal ring and a toggle switch. Remove the electrical junction box (Fig. 5) which is mounted on the inside of the center panel. From inside the unit, insert the chase nipple through the electrical access hole. Slide the seal ring over the chase nipple. Mount the switch box to the outside of the unit by threading the chase nipple into the switch box. Run the three switch leads through the nipple and into the switch box. Connect the green ground lead to the ground screw in the switch box.

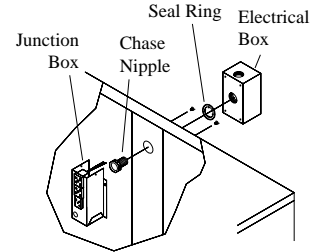

Fig. 5

• **Supply power to unit.** Run power to the external switch box and connect to the two poles of the toggle switch. Connect the gray and white leads from the cooler electrical box to the two poles of the toggle switch. Refer to the appropriate wiring diagram to complete the electrical installation of your cooler. Secure the switch into the switch box and install the gasket and switch cover.

⚠CAUTION: All openings in the external switch box must be sealed to prevent water from entering the switch box.

⚠CAUTION: Pump receptacles are for grounded evaporative cooler pumps only. Do not plug anything else into receptacle.

⚠WARNING: Make sure that cooler cabinet is properly grounded to a suitable ground connection for maximum safety.

Thermostat Installation

- 1) Find a suitable location for the wall thermostat (away from sources of heat, sunlight, or ventilation, and between 4 and 6 feet from the floor). The thermostat may be mounted to a standard electrical box.
- 2) Route an insulated four-conductor thermostat cable (or similar) from the Control Box inside the cooler to the thermostat electrical box. This cable is not supplied. **⚠WARNING:** The thermostat cable should not be routed next to or enter the cabinet through the same inlet as the power supply wire.
- 3) Connect the thermostat wires to the terminals on the back of the wall control and to the terminals located on the left side of the control box in the unit. Make sure to follow the color code found next to each terminal.

Amperage Draw And Belt Tension

This unit is equipped with an adjustable motor drive sheave for adjusting the blower wheel speed to the proper loading on different duct systems. It is important that the motor drive pulley is adjusted to correct size to assure maximum air delivery without damage to the motor. Be sure to follow these instructions carefully.

• **Adjust drive pulley.** After the unit is completely installed, adjust the drive pulley to the least diameter and adjust belt tension. See the maintenance section for adjusting belt tension.

Required Exhaust Openings

An often misunderstood concept of evaporative cooling is the amount of air that should be exhausted. How much should you open your windows? The fact is that most people do not open their windows enough. The following two methods will help you determine the amount to open your windows.

First Method

You should allow an opening of at least 2 square feet (288 square inches) for each 1000 CFM rating of your unit. **Example:** At 3790 CFM, model AD1C51 (3/4 hp) requires 7.6 square feet (1094 square inches) of opening ($3790/1000 * 2 = 7.6$). Multiply the number of windows by window width in inches and divide this into the number of square inches required for your size unit. This will give you the height to open windows. In this example, four 36 inch wide windows should be opened 7.6 inches each.

Champion Air Balancing Method

1. Take a piece of tissue paper and cut it lengthwise into 3 equal strips.
2. Turn your cooler on high cool.
3. Open one window at least six inches wide in each room that you want to cool.
4. Take the piece of tissue paper and put it up against the screen of the open window furthest from the cooler discharge opening. Let go of it. It will do one of three things.

IF It falls down.
THEN CLOSE all of the windows one inch and try step 4 again.

IF It plasters itself to the screen.
THEN OPEN all of the windows one inch and try step 4 again.

IF It stays on the screen lightly.
THEN PERFECT. You are done. Enjoy your cooler.

NOTES:

- When switching to low cool, you must rebalance your home. Repeat step 4.
- Once you balance your home you can cool some areas more than others by opening those windows more and closing the others by the same amount. Repeat step 4 to make sure your home is still air balanced.

Maintenance

⚠WARNING: Before doing any maintenance be sure power is off. At the time you remove either inspection panel be sure to unplug motor and pumps. This is for your safety.

Spring Start-Up

- **Clean pads.** A clean pad is more absorbent, efficient and will give more cool air. Annually, or when required, using a garden hose with nozzle, back wash to clean out the openings, then clean off the inlet face any scale or other obstruction to the passages. Slight scraping may be required to remove hardened scale.
- **Change pads if necessary.** The pads should be replaced after 5 years or if necessary. To change pads, remove top access panel, remove grill, and disconnect water delivery tube. Remove water distributor holder and lift out media sections. Replace with the same type media. You can purchase them from your dealer.

IMPORTANT: In order to get the best performance from your cooling pads, they must be installed properly. If you have purchased a pad with two equal angles, the following instructions can be disregarded. Pads must always be installed with the steeper flute angle sloping down towards the air entering side (Fig. 7). The reason is simple. The steeper angle puts more water on the hot, dry, dirty side of the pad where it is needed most. It also counteracts the tendency of the air to push the water toward the back of the pad.

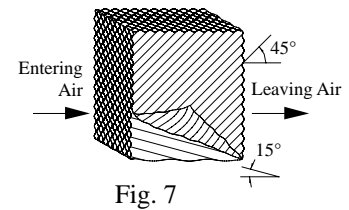

- **Check belt tension.** A 3 lb. force should deflect the belt 3/4 inches (see Fig. 8). Readjust belt if needed.

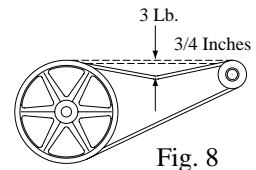

- **Oil bearings.** The blower bearings and cooler motor in this unit should be oiled with a few drops of non-detergent 20/30 weight oil once each year. The motor does not need oil if it has no oil lines for oiling. Motors that have no oil lines are lifetime oiled at the factory and require no further oiling for the life of the unit.

⚠CAUTION: Do not over oil. Over oiling can cause motor burn out, due to excessive oil getting into motor winding.

- **Clean water pump and dump pump.** Cleaning both pumps is necessary once a year at start-up. For your safety, turn unit off and unplug motor and pumps. Remove the pump from the mount slot. Remove the base of the pump as shown in Fig. 9. Clean the pump and turn the impeller to ensure free operation. Remove the pump spout and check for any blockage. After cleaning, reinstall the base onto the pump. Press firmly to make sure it is secure. Reattach the pump to the mount in the cooler using the plastic retainer to ensure that the pump will not overturn. Do not forget to replace the spout and water delivery tube onto the pump outlet.

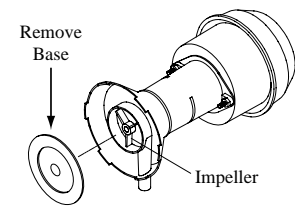

Winter Shut-Down

- **Drain water.** Always drain all of the water out of the cooler and water supply line when not in use for prolonged periods, and particularly at the end of the season. Keep the water line disconnected from both the unit and water supply so that it does not freeze.
- **Unplug motor and pumps.** When cooler is not used for extended periods unplug the motor and pumps from inside cooler.
- **Cover unit.** To protect the life of the finish, a cover for the unit is suggested in extended periods of non use.

By following the operating, installation, and maintenance suggestions as outlined, you can get many years of efficient and satisfactory service from your cooler. In the event additional information is desired, your dealer will be more than glad to assist you in every possible way.

Troubleshooting Guide

<u>Problem</u>	<u>Possible Cause</u>	<u>Remedy</u>
Failure to start or no air delivery/ No LCD display	<ol style="list-style-type: none"> No electrical power to unit <ul style="list-style-type: none"> Fuse blown Circuit breaker tripped Motor overheated <ul style="list-style-type: none"> Belt too tight Blower bearings dry Motor pulley diameter too large Motor locked Fuse blown in unit control box Incorrect wiring between wall thermostat and cooler Poor connection to Fan motor terminals Unit control board or wall thermostat faulty 	<ol style="list-style-type: none"> Check power <ul style="list-style-type: none"> Replace fuse Re-set breaker Determine cause <ul style="list-style-type: none"> Adjust belt tension Oil blower bearings Adjust pulley to correct diameter Replace motor Replace Fuse Check that wiring is correct and secured to terminals Check connections to terminal Supply power to control box and check DC voltage at wall thermostat <ul style="list-style-type: none"> If voltage between Black & Red terminals is close to 3.5VDC and LCD is blank - wall thermostat is faulty If voltage is much less than 3.5VDC, remove red wire from terminal. If voltage rises to 3.5VDC - thermostat is faulty. If voltage remains low - unit control board is faulty.
Inadequate air delivery with cooler running	<ol style="list-style-type: none"> Insufficient air exhaust Belt too loose Pads plugged Motor underloaded 	<ol style="list-style-type: none"> Open windows or doors to increase air flow Adjust belt tension or replace if needed Clean pads Adjust pulley

<u>Problem</u>	<u>Possible Cause</u>	<u>Remedy</u>
Water draining onto roof	<ol style="list-style-type: none"> Float arm not adjusted properly Overflow assembly leaking 	<ol style="list-style-type: none"> Adjust float Tighten nut and overflow pipe
Musty or unpleasant odor	<ol style="list-style-type: none"> Stale or stagnate water in cooler 	<ol style="list-style-type: none"> Drain pan and clean pads
Motor cycles on and off	<ol style="list-style-type: none"> Low voltage Excessive belt tension Blower shaft tight or locked Bearings dry Motor pulley diameter too large causing motor overload 	<ol style="list-style-type: none"> Check voltage Adjust belt tension Oil or replace bearings (Unplug unit) Oil bearings Adjust pulley so full load ampere rating of motor is not exceeded
Noisy	<ol style="list-style-type: none"> Bearings dry Wheel rubbing blower housing Loose parts 	<ol style="list-style-type: none"> Oil bearings Inspect and realign (Unplug unit) Tighten loose parts
Inadequate cooling	<ol style="list-style-type: none"> Inadequate exhaust in house Pads not wet <ul style="list-style-type: none"> Pads plugged Dist. tube holes clogged Pump not working properly Poor connection to Pump terminals on Control Board 	<ol style="list-style-type: none"> Open windows or doors to increase air flow Check water distribution system <ul style="list-style-type: none"> Clean pads Clean Replace or clean pump (Unplug unit) Check connections
Excessive humidity in house	<ol style="list-style-type: none"> Insufficient air exhaust 	<ol style="list-style-type: none"> Open doors or windows

Register your product online at www.championcooler.com/eac/online-registration-eac.htm

Limited Warranty

This warranty is extended to the original purchaser of an evaporative cooler installed and used under normal conditions. It does not cover damages incurred through accident, neglect, or abuse by the owner. We do not authorize any person or representative to assume for us any other or different liability in connection with this product.

Terms And Conditions Of Warranty

Lifetime Limited Coverage on water reservoir against any leakage due to defects in material. From date of purchase, if any original component part provided by Champion Cooler fails due to defect in material or factory workmanship only, we will provide the replacement part as follows:

- One year on the cabinet components.
- Five years on the evaporative media.
- Two years on the original blower motor if furnished by Champion Cooler.

Exclusions From The Warranty

We are not responsible for any incidental or consequential damage resulting from any malfunction.

We are not responsible for any damage received from the use of water softeners, chemicals, descale material, plastic wrap, or if a motor of a higher horsepower than what is shown on the serial plate is used in the unit.

We are not responsible for the cost of service calls to diagnose cause of trouble, or labor charge to repair and/or replace parts.

How To Obtain Service Under This Warranty

Contact the Dealer where you purchased the evaporative cooler. If for any reason you are not satisfied with the response from the dealer, contact the Customer Service Department: Champion Cooler, 5800 Murray Street, Little Rock, Arkansas 72209. 1-800-643-8341. E-mail: info@championcooler.com.

This limited warranty applies to original purchaser only.

Replacement Parts List / *Lista De Piezas De Repuesto*

When ordering parts, please be sure to furnish the following information on all orders. Failure to do so may delay your order. /
 Al pedir piezas, incluya toda la información siguiente con su pedido. El no proporcionar toda esta información resultará en una demora.

1. Cooler model number / *El modelo de su enfriador*
2. Cooler serial number / *Número de serie de la unidad*
3. Description and part number / *Descripción y número de pieza*
4. Date of purchase / *Fecha de compra*

No. N°	Description / Descripción	AD1C51 AD2C51	AD1C5112 AD2C5112	AD1C71 AD2C71	AD1C7112 AD2C7112
1.	Top, Cabinet / <i>Tapa De La Caja</i>	222130-070	222130-070	222140-053	222140-053
2.	Top Access Panel / <i>Panel Superior De Acceso</i>	222130-074	222130-075	222130-074	222130-075
3.	Bottom, Blower Section / <i>Base De La Sección De La Rueda</i>	322130-068	322130-068	322140-051	322140-051
4.	Bottom, Wet Module / <i>Base De La Sección De Agua</i>	222130-072	222130-073	222130-072	222130-073
5.	Front Panel / <i>Panel Del Frente</i>	222130-076	222130-076	222140-055	222140-055
6.	Inspection Panel / <i>Panel De Inspección</i>	224130-002	224130-002	224140-002	224140-002
7.	Center Post, Right / <i>Poste Central, Derecho</i>	222130-062	222130-062	222140-045	222140-045
8.	Center Post, Left / <i>Poste Central, Izquierdo</i>	222130-063	222130-063	222140-046	222140-046
9.	Back Post, Right / <i>Poste Trasero, Derecho</i>	222130-064	222130-066	222140-047	222140-049
10.	Back Post, Left / <i>Poste Trasero, Izquierdo</i>	222130-065	222130-067	222140-048	222140-050
11.	Blower Housing / <i>Caja De La Rueda</i>	324130-202	324130-202	324140-202	324140-202
12.	Cut-Off Plate / <i>Placa Externa</i>	224003-015	224003-015	224004-003	224004-003
13.	Blower Housing Supports / <i>Soporte Para La Caja De La Rueda</i>	218001-034	218001-034	218001-037	218001-037
14.	Grill / <i>Parrilla</i>	222130-078	222130-078	222140-057	222140-057
15.	Electrical Junction Box / <i>Caja De Empalme</i>	322009-001	322009-001	322009-001	322009-001
16.	Motor Mount / <i>Montura Del Motor</i>	314003-011	314003-011	314003-012	314003-012
17.	Motor Mount Clips / <i>Seguros Para Montar Motor</i>	314005-001	314005-001	314005-001	314005-001
18.	Motor / <i>Motor</i>	*	*	*	*
19.	Pulley, Motor / <i>Polea Del Motor</i>	110279-004	110279-004	110279-003	110279-003
20.	Electrical Cord, Motor (115V) / <i>Cable Eléctrico Del Motor (115V)</i>	110372	110372	110372	110372
20.	Electrical Cord, Motor (230V) / <i>Cable Eléctrico Del Motor (230V)</i>	110372-2	110372-2	110372-2	110372-2
21.	Shaft, Blower Wheel / <i>Eje De La Rueda</i>	110183	110183	110183	110183
22.	Blower Wheel / <i>Rueda</i>	16BW	16BW	20BW	20BW
23.	Pulley, Blower Wheel / <i>Polea De La Rueda</i>	110275	110275	110276	110276
24.	Drive Belt / <i>Correa</i>	110229	110229	110230	110230
25.	Bearings, Blower Wheel Shaft / <i>Cojinetes Del Eje De La Rueda</i>	110351	110351	110351	110351
26.	Receptacle, Motor / <i>Toma De Corriente Del Motor</i>	110393	110393	110393	110393
27.	Receptacle, Pump / <i>Toma De Corriente De La Bomba</i>	110361	110361	110361	110361
28.	Media Shield Right / <i>Protector Para El Medio Evaporativo, Derecho</i>	281043-002	281045-002	281044-002	281046-002
29.	Media Shield Left / <i>Protector Para El Medio Evaporativo, Izquierdo</i>	281043-001	281045-001	281044-001	281046-001
30.	Water Distributor Housing / <i>Caja Del Distribuidor De Agua</i>	281038-001	281033-001	281038-001	281033-001
31.	Water Distributor Tube / <i>Tubo Del Distribuidor De Agua</i>	3D-23	3D-23	3D-23	3D-23
32.	Evaporative Media / <i>Medio Evaporativo</i>	310117-001	310118-001	310117-002	310118-002
33.	Distributor Filter Pad / <i>Filtro Del Distribuidor</i>	110120	110120	110120	110120
34.	Water Reservoir / <i>Bandeja Acumuladora De Agua</i>	281041	281042	281041	281042
35.	Tube, Water Delivery / <i>Tubo De Agua</i>	310716	310716	310716	310716
36.	Over Flow Assembly / <i>Montaje De Desagüe</i>	310571-2	310571-2	310571-2	310571-2
37.	Float Valve / <i>Flotador</i>	FL-C	FL-C	FL-C	FL-C
38.	Float Shield / <i>Salpicadero Del Flotador</i>	281006	281006	281006	281006
39.	Pump / <i>Bomba</i>	**	**	**	**
40.	Pump Screen / <i>Malla Para La Bomba</i>	281001-001	281001-001	281001-001	281001-001
41.	Pump Mount / <i>Montura De La Bomba</i>	218002-012	218002-012	218002-012	218002-012
42.	Pump Retainer / <i>Sujetador De La Bomba</i>	110714	110714	110714	110714
43.	Anti-Flattening Coil / <i>Espiral Protectora</i>	110847	110847	110847	110847
44.	Dump Pump Bracket / <i>Bomba</i>	220101-011	220101-011	220101-011	220101-011
45.	Thermostat Mounting Bracket / <i>Soporte Del Termostato</i>	220101-010	220101-010	220101-010	220101-010
46.	T'Stat Thermostat Controls / <i>Controles De Termostato</i>	110423	110423	110423	110423
47.	Switch Box / <i>Caja De Interruptor</i>	110821	110821	110821	110821
48.	Toggle Switch / <i>Interruptor De Palanca</i>	110419	110419	110419	110419
49.	Switchbox Cover & Gasket / <i>Cubierta y Junta De La Caja Del Interruptor</i>	110821-1	110821-1	110821-1	110821-1
50.	Liquidtight Conduit / <i>Conduit Flexible</i>	110816	110816	110816	110816
51.	Liquidtight Connectors / <i>Conectores Para Conduit Flexible</i>	110817	110817	110817	110817
52.	Chase Nipple / <i>Niple Roscado</i>	110812	110812	110812	110812

* See the motor specification table on page 12. / *Vea la tabla de especificaciones del motor en la página 12.*

** Pump for 115V units - #110436, Pump for 230V units - #C60P-240 / *Bomba de 115V - #110436, Bomba de 230V - #C60P-240*

NOTE: Standard hardware items may be purchased from your local hardware store.

NOTA: Artículos de uso corriente pueden comprarse en la ferretería de su localidad.

Replacement Parts / Piezas De Repuesto

AD1C51, AD2C51, AD1C5112, AD2C5112,
AD1C71, AD2C71, AD1C7112, AD2C7112

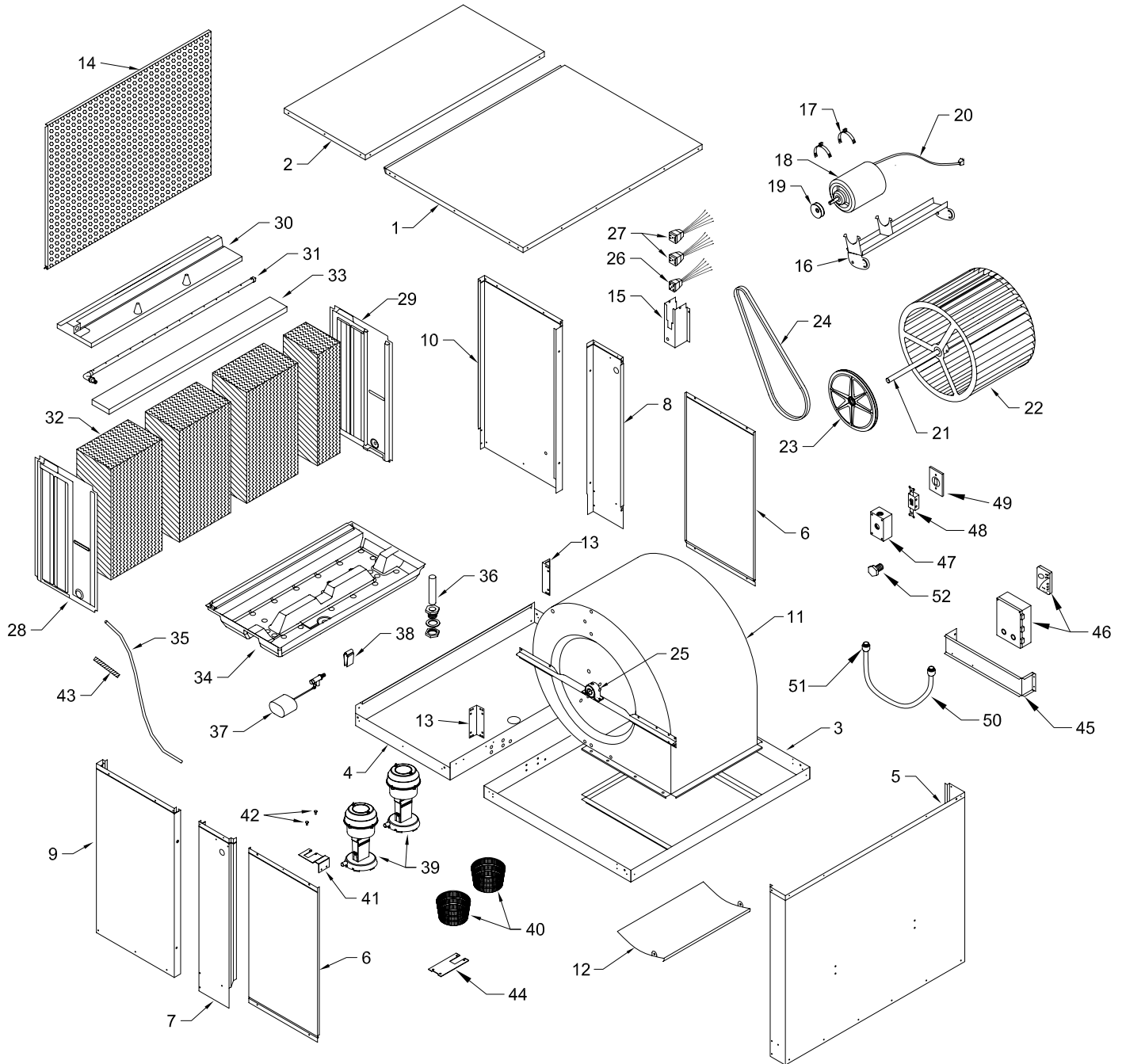

Replacement Parts List / *Lista De Piezas De Repuesto*

When ordering parts, please be sure to furnish the following information on all orders. Failure to do so may delay your order. /
Al pedir piezas, incluya toda la información siguiente con su pedido. El no proporcionar toda esta información resultará en una demora.

1. Cooler model number / *El modelo de su enfriador*
2. Cooler serial number / *Número de serie de la unidad*
3. Description and part number / *Descripción y número de pieza*
4. Date of purchase / *Fecha de compra*

No. N°	Description / Descripción	AS1C51 AS2C51	AS1C5112 AS2C5112	AS1C71 AS2C71	AS1C7112 AS2C7112
1.	Top, Cabinet / <i>Tapa De La Caja</i>	222130-070	222130-070	222140-053	222140-053
2.	Top Access Panel / <i>Panel Superior De Acceso</i>	222130-074	222130-075	222130-074	222130-075
3.	Bottom, Blower Section / <i>Base De La Sección De La Rueda</i>	222130-069	222130-069	222140-052	222140-052
4.	Bottom, Wet Module / <i>Base De La Sección De Agua</i>	222130-072	222130-073	222130-072	222130-073
5.	Front Panel / <i>Panel Del Frente</i>	322130-077	322130-077	322140-056	322140-056
6.	Inspection Panel / <i>Panel De Inspección</i>	224130-002	224130-002	224140-002	224140-002
7.	Center Post, Right / <i>Poste Central, Derecho</i>	222130-062	222130-062	222140-045	222140-045
8.	Center Post, Left / <i>Poste Central, Izquierdo</i>	222130-063	222130-063	222140-046	222140-046
9.	Back Post, Right / <i>Poste Trasero, Derecho</i>	222130-064	222130-066	222140-047	222140-049
10.	Back Post, Left / <i>Poste Trasero, Izquierdo</i>	222130-065	222130-067	222140-048	222140-050
11.	Blower Housing / <i>Caja De La Rueda</i>	324130-203	324130-203	324140-203	324140-203
12.	Cut-Off Plate / <i>Placa Externa</i>	224003-015	224003-015	224004-003	224004-003
13a.	Blower Housing Support, Right / <i>Soporte Para La Caja De La Rueda, Derecho</i>	218001-035	218001-035	218001-038	218002-038
13b.	Blower Housing Support, Left / <i>Soporte Para La Caja De La Rueda, Izquierdo</i>	218001-036	218001-036	218001-038	218002-038
14.	Grill / <i>Parrilla</i>	222130-078	222130-078	222140-057	222140-057
15.	Electrical Junction Box / <i>Caja De Empalme</i>	322009-001	322009-001	322009-001	322009-001
16.	Motor Mount / <i>Montura Del Motor</i>	314003-011	314003-011	314003-012	314003-012
17.	Motor Mount Clips / <i>Seguros Para Montar Motor</i>	314005-001	314005-001	314005-001	314005-001
18.	Motor / <i>Motor</i>	*	*	*	*
19.	Pulley, Motor / <i>Polea Del Motor</i>	110279-004	110279-004	110279-003	110279-003
20.	Electrical Cord, Motor (115V) / <i>Cable Eléctrico Del Motor (115V)</i>	110372	110372	110372	110372
20.	Electrical Cord, Motor (230V) / <i>Cable Eléctrico Del Motor (230V)</i>	110372-2	110372-2	110372-2	110372-2
21.	Shaft, Blower Wheel / <i>Eje De La Rueda</i>	110183	110183	110183	110183
22.	Blower Wheel / <i>Rueda</i>	16BW	16BW	20BW	20BW
23.	Pulley, Blower Wheel / <i>Polea De La Rueda</i>	110275	110275	110276	110276
24.	Drive Belt / <i>Correa</i>	110212	110212	110213	110213
25.	Bearings, Blower Wheel Shaft / <i>Cojinetes Del Eje De La Rueda</i>	110351	110351	110351	110351
26.	Receptacle, Motor / <i>Toma De Corriente Del Motor</i>	110393	110393	110393	110393
27.	Receptacle, Pump / <i>Toma De Corriente De La Bomba</i>	110361	110361	110361	110361
28.	Media Shield, Right / <i>Protector Para El Medio Evaporativo, Derecho</i>	281043-002	281045-002	281044-002	281046-002
29.	Media Shield, Left / <i>Protector Para El Medio Evaporativo, Izquierdo</i>	281043-001	281045-001	281044-001	281046-001
30.	Water Distributor Housing / <i>Caja Del Distribuidor De Agua</i>	281038-001	281033-001	281038-001	281033-001
31.	Water Distributor Tube / <i>Tube Del Distribuidor De Agua</i>	3D-23	3D-23	3D-23	3D-23
32.	Evaporative Media / <i>Medio Evaporativo</i>	310117-001	310118-001	310117-002	310118-002
33.	Distributor Filter Pad / <i>Filtro Del Distribuidor</i>	110120	110120	110120	110120
34.	Water Reservoir / <i>Bandeja Acumuladora De Agua</i>	281041	281042	281041	281042
35.	Tube, Water Delivery / <i>Tube De Agua</i>	310716	310716	310716	310716
36.	Over Flow Assembly / <i>Montaje De Desagüe</i>	310571-2	310571-2	310571-2	310571-2
37.	Float Valve / <i>Flotador</i>	FL-C	FL-C	FL-C	FL-C
38.	Float Shield / <i>Salpicadero Del Flotador</i>	281006	281006	281006	281006
39.	Pump Assembly / <i>Bomba</i>	**	**	**	**
40.	Pump Screen / <i>Malla Para La Bomba</i>	281001-001	281001-001	281001-001	281001-001
41.	Pump Mount / <i>Montura De La Bomba</i>	218002-012	218002-012	218002-012	218002-012
42.	Pump Retainer / <i>Sujetador De La Bomba</i>	110714	110714	110714	110714
43.	Anti-Flattening Coil / <i>Espiral Protectora</i>	110847	110847	110847	110847
44.	Dump Pump Bracket / <i>Bomba</i>	220101-011	220101-011	220101-011	220101-011
45.	Thermostat Mounting Bracket / <i>Soporte Del Termostato</i>	220101-010	220101-010	220101-010	220101-010
46.	T'Stat Thermostat Controls / <i>Controles De Termostato</i>	110423	110423	110423	110423
47.	Switch Box / <i>Caja De Interruptor</i>	110821	110821	110821	110821
48.	Toggle Switch / <i>Interruptor De Palanca</i>	110419	110419	110419	110419
49.	Switchbox Cover & Gasket / <i>Cubierta y Junta De La Caja Del Interruptor</i>	110821-1	110821-1	110821-1	110821-1
50.	Liquidtight Conduit / <i>Conduit Flexible</i>	110816	110816	110816	110816
51.	Liquidtight Connectors / <i>Conectores Del Conduit Flexible</i>	110817	110817	110817	110817
52.	Chase Nipple / <i>Niple Roscado</i>	110812	110812	110812	110812

* See the motor specification table on page 12. / *Vea la tabla de especificaciones del motor en la página 12.*

** Pump for 115V units - #110436, Pump for 230V units - #C60P-240 / *Bomba de 115V - #110436, Bomba de 230V - #C60P-240*

NOTE: Standard hardware items may be purchased from your local hardware store.

NOTA: Artículos de uso corriente pueden comprarse en la ferretería de su localidad.

Replacement Parts / Piezas De Repuesto

AS1C51, AS2C51, AS1C5112, AS2C5112
AS1C71, AS2C71, AS1C7112, AS2C7112

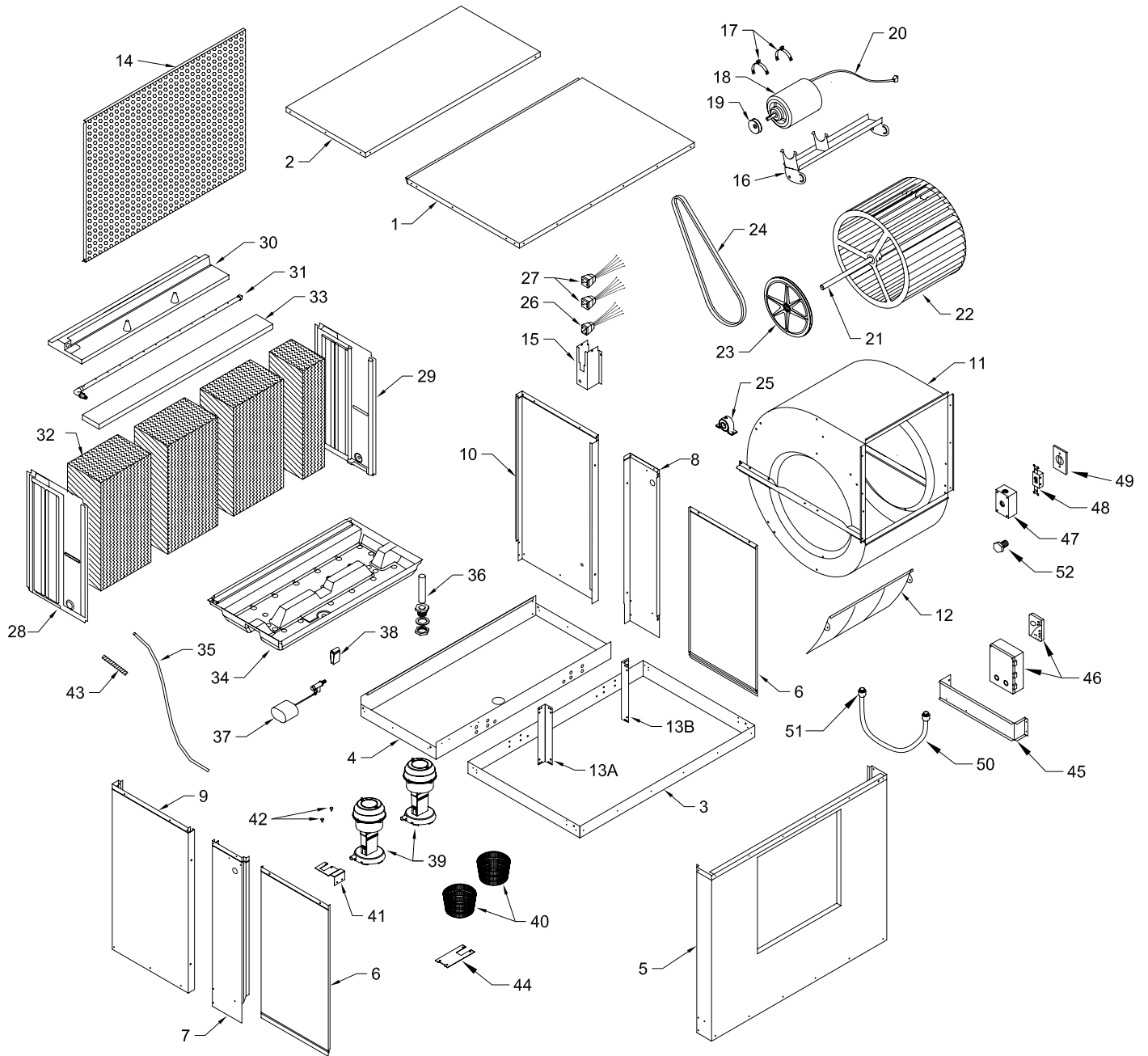

Replacement Parts List / *Lista De Piezas De Repuesto*

When ordering parts, please be sure to furnish the following information on all orders. Failure to do so may delay your order. /
Al pedir piezas, incluya toda la información siguiente con su pedido. El no proporcionar toda esta información resultará en una demora.

1. Cooler model number / *El modelo de su enfriador*
2. Cooler serial number / *Número de serie de la unidad*
3. Description and part number / *Descripción y número de pieza*
4. Date of purchase / *Fecha de compra*

No.	Description / Descripción	AU1C7112
N°	Descripción / Descripción	AU2C7112
1.	Top, Cabinet / <i>Tapa De La Caja</i>	322140-053
2.	Top Access Panel / <i>Panel Superior De Acceso</i>	222130-075
3.	Bottom, Blower Section / <i>Base De La Sección De La Rueda</i>	222140-052
4.	Bottom, Wet Module / <i>Base De La Sección De Agua</i>	222130-073
5.	Front Panel / <i>Panel Del Frente</i>	222140-058
6.	Inspection Panel / <i>Panel De Inspección</i>	224140-002
7.	Center Post, Right / <i>Poste Central, Derecho</i>	222140-045
8.	Center Post, Left / <i>Poste Central, Izquierdo</i>	222140-046
9.	Back Post, Right / <i>Poste Trasero, Derecho</i>	222140-049
10.	Back Post, Left / <i>Poste Trasero, Izquierdo</i>	222140-050
11.	Blower Housing / <i>Caja De La Rueda</i>	324140-204
12.	Cut-Off Plate / <i>Placa Externa</i>	224004-003
13.	Blower Support Bracket / <i>Soporte Para La Caja De La Rueda</i>	218001-038
14.	Grill / <i>Parrilla</i>	222140-057
15.	Electrical Junction Box / <i>Caja De Empalme</i>	322009-001
16.	Motor Mount / <i>Montura Del Motor</i>	314003-012
17.	Motor Mount Clips / <i>Seguros Para Montar Motor</i>	314005-001
18.	Motor / <i>Motor</i>	*
19.	Pulley, Motor / <i>Polea Del Motor</i>	110279-003
20.	Electrical Cord, Motor (115V) / <i>Cable Eléctrico Del Motor (115V)</i>	110372-1
20.	Electrical Cord, Motor (230V) / <i>Cable Eléctrico Del Motor (230V)</i>	110372-2
21.	Shaft, Blower Wheel / <i>Eje De La Rueda</i>	110183
22.	Blower Wheel / <i>Rueda</i>	20BW
23.	Pulley, Blower Wheel / <i>Polea De La Rueda</i>	110276
24.	Drive Belt / <i>Correa</i>	110213
25.	Bearings, Blower Wheel Shaft / <i>Cojinetes Del Eje De La Rueda</i>	110351
26.	Receptacle, Motor / <i>Toma De Corriente Del Motor</i>	110393
27.	Receptacle, Pump / <i>Toma De Corriente De La Bomba</i>	110361
28.	Media Shield, Right / <i>Protector Para El Medio Evaporativo, Derecho</i>	281046-002
29.	Media Shield, Left / <i>Protector Para El Medio Evaporativo, Izquierdo</i>	281046-001
30.	Water Distributor Housing / <i>Caja Del Distribuidor De Agua</i>	281033-001
31.	Water Distributor Tube / <i>Tubo Del Distribuidor De Agua</i>	3D-23
32.	Evaporative Media / <i>Medio Evaporativo</i>	310118-002
33.	Distributor Filter Pad / <i>Filtro Del Distribuidor</i>	110120
34.	Water Reservoir / <i>Bandeja Acumuladora De Agua</i>	281042
35.	Tube, Water Delivery / <i>Tubo De Agua</i>	310716
36.	Over Flow Assembly / <i>Montaje De Desagüe</i>	310571-2
37.	Float Valve / <i>Flotador</i>	FL-C
38.	Float Shield / <i>Salpicadero Del Flotador</i>	281006
39.	Pump / <i>Bomba</i>	**
40.	Pump Screen / <i>Malla Para La Bomba</i>	281001-001
41.	Pump Mount / <i>Montura De La Bomba</i>	218002-012
42.	Pump Retainer / <i>Sujetador De La Bomba</i>	110714
43.	Anti-Flattening Coil / <i>Espiral Protectora</i>	110847
44.	Dump Pump Bracket / <i>Bomba</i>	220101-011
45.	Thermostat Mounting Bracket / <i>Soporte Del Termostato</i>	220101-010
46.	T Stat Thermostat Controls / <i>Controles De Termostato</i>	110423
47.	Switch Box / <i>Caja De Interruptor</i>	110821
48.	Toggle Switch / <i>Interruptor De Palanca</i>	110419
49.	Switchbox Cover & Gasket / <i>Cubierta y Junta De La Caja Del Interruptor</i>	110821-1
50.	Liquidtight Conduit / <i>Conduit Flexible</i>	110816
51.	Liquidtight Connectors / <i>Conectores Para Conduit Flexible</i>	110817
52.	Chase Nipple / <i>Niple Roscado</i>	110812

* See the motor specification table on page 12. / *Vea la tabla de especificaciones del motor en la página 12.*

** Pump for 115V units - #110436, Pump for 230V units - #C60P-240 / *Bomba de 115V - #110436, Bomba de 230V - #C60P-240*

NOTE: Standard hardware items may be purchased from your local hardware store.

NOTA: Artículos de uso corriente pueden comprarse en la ferretería de su localidad.

Replacement Parts / Piezas De Repuesto

AU1C7112, AU2C7112

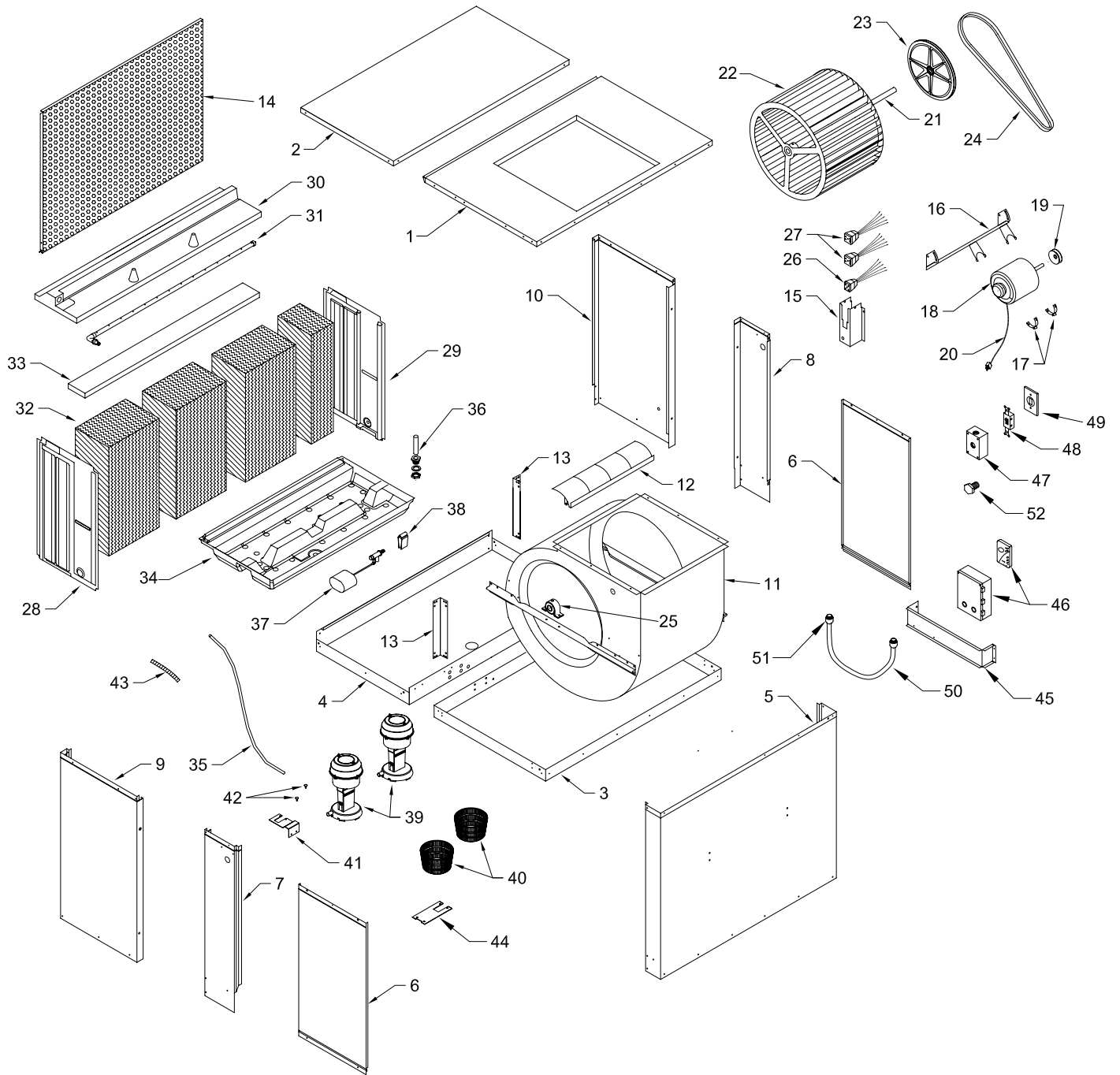

General Specifications / Especificaciones Generales

Models Modelos	Weight (lbs.) Peso (libras)		Cabinet Dimensions (in.) Dimensiones De La Caja (pulgadas)			Duct Opening (in.) Abertura De Ducto (pulgadas)	
	Dry Seco	Operating Lleno	Height Altura	Width Anchura	Depth Profundidad	Width Anchura	Height Altura
AD1C51, AD2C51, AS1C51, AS2C51	183	233	28	42	45	17 3/4	17 3/4
AD1C5112, AD2C5112, AS1C5112, AS2C5112	196	263	28	42	49	17 3/4	17 3/4
AD1C71, AD2C71, AS1C71, AS2C71	219	269	34 5/8	42	48	19 3/4	19 3/4
AD1C7112, AD2C7112, AS1C7112, AS2C7112, AU1C7112, AU2C7112	239	306	34 5/8	42	52	19 3/4	19 3/4

Motor Specifications / Especificaciones Del Motor

Models Modelos	HP C.V.	Motor # Motor - N°	Speed Velocidad	Volts Voltios	*Amps Amperaje	Motor Pulley # Polea Del Motor-N°	Model Modelo	Drive Belt Part # Correa - N°
AD1C51, AD1C5112, AS1C51, AS1C5112	3/4	110449	2	115	15.8	110279-004	AD1C51, AD1C5112	110229 (4L-530)
							AS1C51, AS1C5112	110212 (4L-570)
AD2C51, AD2C5112, AS2C51, AS2C5112	3/4	110480	2	230	8.3	110279-004	AD2C51, AD2C5112	110229 (4L-530)
							AS2C51, AS2C5112	110212 (4L-570)
AD1C71, AD1C7112, AS1C71, AS1C7112, AU1C7112	1	110471	2	115	18	110279-003	AD1C71, AD1C7112	110230 (4L-640)
							AS1C71, AS1C7112	110213 (4L-670)
							AU1C7112	110214 (4L-690)
AD2C71, AD2C7112, AS2C71, AS2C7112, AU2C7112	1	110458	2	230	9.4	110279-003	AD2C71, AD2C7112	110230 (4L-640)
							AS2C71, AS2C7112	110213 (4L-670)
							AU2C7112	110214 (4L-690)

*Motor amperage based on National Electrical Code. Use motor nameplate amperage when sizing electrical components. / El amperaje listado es del código eléctrico nacional. Utilize el amperaje indicado en la placa del motor para determinar los componentes eléctricos.

Lea Y Conserve Estas Instrucciones

Reglas De Seguridad

1. Lea las instrucciones con cuidado.
2. Las conexiones eléctricas deben ser hechas por un electricista competente, para que todo el cableado eléctrico cumpla con los requisitos establecidos en su localidad.
3. Siempre **CORTE LA CORRIENTE** y **DESCONECTE** el motor y la bomba en el interior del aparato antes de instalar o realizar cualquier labor de mantenimiento.
4. El motor y la bomba están provistos de clavijas moldeadas, con toma de tierra, y se apagarán automáticamente en caso de sobrecalentamiento. Los motores volverán a funcionar cuando se enfrían.

⚠️ ADVERTENCIA: Para reducir el riesgo de incendio o toques eléctricos, no use este ventilador con ningún "dispositivo de estado sólido para controlar la velocidad del ventilador."

Enfriamiento Por Evaporación

El enfriamiento por medio de evaporación es la manera de la naturaleza de refrescarse. Cuando el aire se mueve sobre una superficie mojada, se evapora el agua y se absorbe el calor. Al salir de una piscina con el viento que sopla usted se siente fresco, aunque el aire puede ser caliente. El cuerpo humano sí mismo es refrescado principalmente por la evaporación del sudor.

Este enfriador funciona usando el mismo principio. El aire se traza a través de los filtros mojados donde el aire se enfría por medio de evaporación y después circula a través del edificio. Se hace frío de la sensación cuando tiene esta combinación del aire enfriado y del movimiento del aire sobre la piel.

A diferencia de los acondicionadores de aire que recirculan el aire, un enfriador evaporativo trae continuamente por dentro el aire fresco mientras agota el aire viejo. Se reemplaza completamente el aire cada 2 a 4 minutos, abriendo las ventanas o las puertas o una combinación de ambas. El aire es siempre fresco, no es viciado, cargado de humo y olores como ocurre con los sistemas de aire acondicionado a base de refrigeración.