

veam cannon

# Rail Product Selection Guide

Proven rail expertise.  
Global capabilities.



**ITT**

ENGINEERED FOR LIFE

# We Connect Passenger

For more than a century, ITT has developed innovative connector solutions for the world's harshest environments. With facilities in the United States, Germany, Italy, Mexico, China and Japan, each with its unique strengths, we offer our customers Interconnect Solutions that are truly Engineered for Life.

In addition to this global footprint, we offer highly specialized rail industry expertise. We have a proven track record as an industry leader in harsh-environment applications. This has equipped us with the knowledge needed to continue to produce extremely advanced, resilient and reliable connectors for our customers' most challenging rail applications.

## Global interconnect solutions for the rail industry.

### The ITT Veam and Cannon difference

- Global capabilities & local support
- Proven rail application expertise
- A century of rail interconnect leadership
- A committed innovator & business partner

### About ITT

ITT is a diversified leading manufacturer of highly engineered critical components and customized technology solutions for the energy, transportation and industrial markets. Building on its heritage of innovation, ITT partners with its customers to deliver enduring solutions to the key industries that underpin our modern way of life. Founded in 1920, ITT is headquartered in White Plains, N.Y., with employees in more than 35 countries and sales in a total of approximately 125 countries. For more information, visit [www.itt.com](http://www.itt.com).

# veam cannon

### Industry-recognised safety and reliability



# ect

# s to their next adventure

As a critical part of the nervous system of modern rail, our connector solutions are found in a diverse range of INFRASTRUCTURE and ROLLING STOCK applications throughout the globe.









From high volume standardized products to low volume highly customized connector and value added solutions we have the reach, scale and expertise to deliver - whatever the requirement.

- Fully Proven
- Incredibly Durable
- Ultra Reliable





























## Infrastructure Applications

An integral part of the infrastructure and electrical control functions on current and next-generation railway systems, our connector solutions perform in both on and off-board applications that include:

-  Level Crossing
-  RCE Cabinets (Event Tracker Record)
-  Signaling
-  Station Platform Information
-  Switches
-  Train Control
-  Video Surveillance
-  Warning Systems

## Rolling Stock Applications

Qualified on more than 250 global rail programs and being an integral part of more than 100,000 trains, our connector solutions are engineered to withstand the harshest environments in applications that include:

-  Automatic Doors
-  Battery Chargers
-  Bogies
-  Brake/Speed Sensors
-  Braking Systems
-  Converters/Inverters
-  Data Communication
-  Detection, Measurement and Control
-  Diagnostics
-  Driver's Cabin
-  Electric Couplers
-  Fire Wall
-  HVAC
-  Intervehicle
-  Lighting
-  Location Systems
-  Pantograph
-  Passenger Onboard Utility Connections
-  Power Distribution
-  Safety
-  Seats
-  Toilets
-  Traction Motors
-  Under Car
-  Wheel Slide Protection (WSP)
-  Wipers





# From Rolling Stock to Rail Infrastructure We Connect When it matters most.

## TRAIN CONTROL

ITT Veam and Cannon connectors support today's advanced train control systems, which include a wide range of on-board systems, for both PCB and cable applications.

### PRODUCT SOLUTIONS:

FRCIR Standard, CA Bayonet, Trident

## UNDER CAR

ITT Veam connectors support critical signal, power and data communications under train cars, with reliable vibration resistant connectivity enabled by compact solutions suitable for high-density wiring environments.

### PRODUCT SOLUTIONS:

FRCIR Standard, FRCIR290, CIRM12, VBN, Power Plates, Junction Boxes, FRCIR Stainless Steel, VA900

## STATION TECHNOLOGY

ITT Veam and Cannon standard and customized connectors deliver reliable power and signal solutions required by critical station applications as diverse as level crossings, passenger information boards and video surveillance systems.

### PRODUCT SOLUTIONS:

CA Bayonet, CIR M12, CIR Fiber optic, CTC, Trident

## BOGIES

ITT Veam high power single & multi-pole standard and customized connectors deliver both extreme vibration resistance and space saving footprints to ensure reliable power supply and signal transmission to traction systems.

### PRODUCT SOLUTIONS:

FRCIR Standard, FRCIR290, FRMG CIR, FRCIR Stainless Steel, FRCIR Marine Bronze, Power Plates, VA900



The teams at ITT Veam and ITT Cannon have an extensive, in-depth knowledge of rail from the tracks to the engine to the passenger car and every connection, every wire, every socket that makes for a smooth and efficient ride. As we continue to develop leading-edge technology, we'll continue to bring you the reliability and durability required to push the limits of rail.

#### INTERVEHICLE

ITT Veam solutions including connectors, junction boxes and jumper cables support critical signal, power and data communication between train cars, by delivering ultra-reliable vibration and shock resistant connectivity.

#### PRODUCT SOLUTIONS:

FRCIR Standard, FRCIR290, CIRM12, DSR, CIR Fiber Optic, HTB, Junction Boxes, Jumper Cables, FRCIR Marine Bronze

#### SENSORS

ITT Veam connectors are optimized for the very harsh environments of sensor applications, delivering minimized footprints, optimal sealing and extended lifetimes.

#### PRODUCT SOLUTIONS:

FRCIR Standard, FRMG CIR, VBN, FRCIR Stainless Steel, FRCIR Marine Bronze













#### SIGNALING

ITT Veam and Cannon connectors support modern intelligent traffic management systems, which include a diverse range of track-side applications, both inside communications cabinets and in the most exposed outdoor harsh environments.







#### PRODUCT SOLUTIONS:

FRCIR Standard, Jumper Cables, Trident







## STANDARD PRODUCTS



	FRCIR STANDARD	FRCIR290	FRMG CIR	VIP	CIRM12	CA BAYONET	
							
	<b>veam</b>	<b>veam</b>	<b>veam</b>	<b>veam</b>	<b>veam</b>	<b>cannon</b>	
APPLICATIONS							
GENERAL	Standards / Connector Specifications	VG95234 / MIL-DTL-5015 (where applicable)	VG95234 / MIL-DTL-5015 (where applicable)	VG95234 / MIL-DTL-5015 (where applicable)	n/a	VG95234 / MIL-DTL-5015 (where applicable)	VG95234 (where applicable)
	Fire & Smoke standards	EN 45545-2 NFPA 130	EN 45545-2 NFPA 130	EN 45545-2 NFPA 130	UNI 11170 / NFF 16 101/102 EN 45545-2	EN 45545-2 NFF 16-101/102	acc. VG95234
	RoHS and Reach	Yes/No (depending on plating)	Yes/No (depending on plating)	Yes/No (depending on plating)	Yes	Yes/No (depending on plating)	Yes
	Number of Circuits	1 to 159 pins	3 to 101 pins	1 to 159 pins	1 (single pole)	1 to 4 lines	1 to 65 pins
ELECTRICAL	Max. Operating Voltage	4200 Vdc to 3000 Vac	2450 Vdc to 1750 Vac	4200 Vdc to 3000 Vac	1500 Vca to 2000 Vcc	200 Vac to 250 Vdc	50 Vac to 75vdc (acc. Low Voltage Directive)
	Max. Dielectric Withstanding Voltage	7000 Vac rms	4500 Vac rms	7000 Vac	9Kvdc	1000 Vac	3000 Vac
	Max. Current Rating	350A	350A	350A	700A	3A	245A
	EMI/RFI shielding	Yes	Yes	No	n/a	Yes / No (depending on plating)	Yes
CONTACTS	Wire range AWG	AWG 26 to AWG4/0	AWG 20 to 4/0	AWG 26 to AWG4/0	-	AWG 24 (8 poles)	AWG 26 to AWG 0
	Wire Range mm <sup>2</sup>	0.15 to 120	0.6 to 120	0.15 to 120	95 to 240	0.34 to 0.75 (2 and 4 poles)	0.14 to 50
	Contact plating	Gold / Silver	Gold / Silver	Gold / Silver	Silver	Gold	Gold / Silver
	Power and Signal Layouts	Yes	Yes	Yes	Power	No	Yes
MECHANICAL	Contact Size	20 to 4/0	16 to 4/0	20 to 4/0	Special	M12	20 to 0
	Mating cycles (max.)	2000	2000	2000	500	500 (2-4 pole) - 100 (8 pole)	500
	Max. shock resistance (g's)	50	50	50	50	50	50
	Max. vibration resistance	20g - 10 up to 2000Hz	20g - 10 up to 2000Hz	20g - 10 up to 2000Hz	20g - 10 up to 2000Hz	20g - 10 up to 2000Hz	200m/s <sup>2</sup> at 10 - 2000 Hz
	Mechanical coding	Yes	Yes	Yes	Yes	Yes	Yes
ENVIRONMENTAL	Type of coupling	Bayonet	Bayonet	Bayonet	Thread	Bayonet	Bayonet
	Temperature range	-40°C to +125°C	-40°C to +125°C	-40°C to +125°C	-40°C to +100°C	-40°C to +100°C	-55°C to +125°C options for up to 200°C
	IP rating	IP67 (mated condition with appropriate accessories)	IP67 (mated condition with appropriate accessories)	IP67 (mated condition with appropriate accessories)	IP67 (mated condition with appropriate accessories)	IP67 (mated condition with appropriate accessories)	IP67 / IP68 / IP69k
	Individual wire sealing	Yes	Yes	Yes	No	Yes	Yes
	Cable jacket sealing	Yes	Yes	Yes	No	No	Yes
	Shell Material	Aluminum/Stainless steel/ Marine bronze	Aluminum/Stainless steel/ Marine bronze	Aluminum/Stainless steel/ Rubber covered	Thermoplastic	Aluminium	Aluminium
RoHS SHELL PLATING	Insert material	Flame retardant rubber	Flame retardant rubber	Flame retardant rubber	Thermoplastic	Thermoplastic	Chloroprene / KKM
	Conductive (200h)	Yes	Yes	Yes	No	Yes	Yes
	Conductive (500h)	Yes	Yes	No	No	Yes	Yes
	Non-conductive (500h)	Yes	Yes	Yes	No	Yes	No
Non-conductive (1000h)	Yes	Yes	Yes	No	Yes	No	

### APPLICATIONS KEY













**INFRASTRUCTURE APPLICATIONS:** Braking Systems  | Detection, Measurement and Control  | Diagnostics  | Fire Wall  | Level Crossing  | Lighting  | Location System 

Wheel Slide Protection (WSP) 

**ROLLING STOCK APPLICATIONS:** Automatic Doors  | Battery Chargers  | Bogies  | Brake/Speed Sensors  | Converters/Inverters  | Data Communication  | Driver's Cabin 

Under Car  | Wipers 

## STANDARD PRODUCTS







	VBN	VRPC	DSR	FRVPT	CA Com	KPx
						
	veam	veam	veam	veam	cannon	cannon
APPLICATIONS						
GENERAL						
Standards / Connector Specifications	VG95234 / MIL-DTL-5015 (where applicable)	NFF 61030	Shells based on Mil-C-38999, insert on Mil-C-5015	VG95328 / MIL-C-26482 (where applicable)	n/a	VG95328
Fire & Smoke standards	EN 45545-2 NFF16-101/102	EN 45545-2 NFF 16-101/102	EN 45545-2 NFPA 130	EN 45545-2 NFPA 130	acc. VG95234	acc. VG95328
RoHS and Reach	Yes	Yes	Yes/No (depending on plating)	Yes/No (depending on plating)	Yes	Yes
Number of Circuits	4 to 70 pins	3, 6, 12	1 to 159 pins	2 to 61 pins	1 to 65 pins	2 to 61 pins
ELECTRICAL						
Max. Operating Voltage	1250 Vdc to 900 Vac	380 V AC / 500 V DC	4.2kV (depends on insert)	900 Vdc to 1250 Vac	50 Vac to 75 Vdc (acc. Low Voltage Directive)	50 Vac to 75 Vdc (acc. Low Voltage Directive)
Max. Dielectric Withstanding Voltage	3600V rms	3250 V AC	up to 8.5kV (depends on insert)	5000 Vac rms	3000 Vac	2300 Vac
Max. Current Rating	73A	16A	1,000A (using VGE insert and contacts)	41A	245A	13A
EMI/RFI shielding	Yes	No	Consult factory	Yes	Yes	Yes
CONTACTS						
Wire range AWG	AWG 20 to AWG 10	AWG 24 to AWG 14	AWG 24 to 500 MCM	AWG 24 to AWG 12	AWG 26 to AWG 0	AWG 24 to AWG 12
Wire Range mm <sup>2</sup>	0.5 to 10	0.25 to 2.5	0.15 to 240	0.24 to 3	0.14 to 50	0.08 to 2.0
Contact plating	Gold / Silver	Tin / Gold	Gold / Silver	Gold / Silver	Silver	Gold
Power and Signal Layouts	No	No	Yes	No	Yes	Signal only
Contact Size	16S to 8	Ø1.6 mm (size 16)	from 20 to 240 sq mm	12 to 20	20 to 0	20 to 12
MECHANICAL						
Mating cycles (max.)	500	500	500	500	500	500
Max. shock resistance (g's)	50	30	200	Vibration stress 150 m/s <sup>2</sup> , 10 Hz to 2000 Hz	50	50
Max. vibration resistance	25-250Hz (NF F 60-002)	5,72 m/s <sup>2</sup> at 5 to 150Hz	20	-	200m/s <sup>2</sup> at 10 - 2000 Hz	200m/s <sup>2</sup> at 10 - 2000 Hz
Mechanical coding	Yes	Yes	5 keyways	Yes	Yes	Yes
Type of coupling	Bayonet	Snap Lock	Double Ratchet	Reverse Bayonet	Bayonet / Threaded	Bayonet
ENVIRONMENTAL						
Temperature range	-40°C to +100°C	-40°C to +100°C	-70C to 200C (depends on elastomer, consult factory)	-40°C to +125°C	-55°C to +125°C	-55°C to +125°C
IP rating	IP67 (mated condition with appropriate accessories)	IP20 & IP67	IP67 (mated condition with appropriate accessories)	IP67 (mated condition with appropriate accessories)	IP67 / IP68 / IP69k	IP67 / IP68
Individual wire sealing	Yes	Yes (grommet )	No	Yes	Yes	Yes
Cable jacket sealing	Yes	No	Yes	Yes	Yes	Yes
Shell Material	Aluminium	-	Aluminium	Aluminium-stainless steel	Aluminium, Zinc Diecast	Aluminium
Insert material	Thermoplastic	Thermoplastic	Flame retardant rubber	Flame retardant rubber	Polychloroprene	Polychloroprene
ROHS SHELL PLATINGS						
Conductive (200h)	Yes	No	Yes	Yes	No	Yes
Conductive (500h)	Yes	No	Consult factory	Yes	No	Yes (not for DZ back shell )
Non-conductive (500h)	Yes	No	Consult factory	Yes	No	No
Non-conductive (1000h)	Yes	No	Consult factory	Yes	No	No











## STANDARD PRODUCTS



	APD	TRIDENT CIRCULAR	TRIDENT RECTANGULAR	CTC	D-SUB
					
	cannon	cannon	cannon	cannon	cannon
APPLICATIONS					
Standards / Connector Specifications	ISO 15170	EN 61984 / UL 1977	UL 1977 / NFF 61030 (TFR)	-	NASA – S-311-P (where applicable); Backshells Qualified to SAE AS85049/48 and AS85049/50
Fire & Smoke standards	No	UL 94 V-0	UL 94 V-0 Multiway with plastic hoods: UL 94 V-1	UL 94 V-0	UL 94 V-0
RoHS and Reach	Yes	Yes	Yes	Yes	Yes (depending on part)
Number of Circuits	1 to 51	4 to 48	2 to 75	8 to 24	2 to 104
Max. Operating Voltage	Standard 48 Vdc, up to 500 V	250 Vac (THV: 500 V DC/AC)	250 Vac	250 Vac	Up to 250 Vdc
Max. Dielectric Withstanding Voltage	1000 V	2000 Vac (THV: 3500 Vac)	2000 Vac	1550 Vac	1250 Vac
Max. Current Rating	250A	16A (signal); 30A (power)	13A	16A	7.5A for Signal; Up to 65A for Power
EMI/RFI shielding	No	Yes	No	No	Yes / No (depending on Shell Style)
Wire range AWG	AWG 26 to AWG 0	AWG 26 to AWG 12	AWG 26 to AWG 14	AWG 24 to AWG 16	AWG 30 to AWG 8
Wire Range mm <sup>2</sup>	0.35 to 50	0.14 to 2.5 (signal); 0.5 to 4.0 (power)	0.14 to 2.5	0.2 to 1.5	0.05 to 8.37
Contact plating	Tin / Gold / Silver	Tin / Gold	Tin / Gold	Tin / Gold	Tin / Gold
Power and Signal Layouts	Yes	Yes	No	No	Yes (Combo-D)
Contact Size	0 to 16	Ø1.6 mm (size 16)	Ø1.6 mm (size 16)	Ø1.6 mm (size 16)	8 to 22
Mating cycles (max.)	50	500	500	500	500
Max. shock resistance (g's)	30	50	50	50	50 (depending on product sub-family)
Max. vibration resistance	-	100 m/s <sup>2</sup> at 10-500 Hz	100 m/s <sup>2</sup> at 10-500 Hz	100 m/s <sup>2</sup> at 10-500 Hz	20 g <sub>r</sub> peak (depending on product sub-family)
Mechanical coding	Yes	Yes	Yes	Yes	Yes on Customs/Specials Only
Type of coupling	Bayonet	Bayonet	Snap Lock	Snap Lock	None (Require Locking/ Coupling Hardware)
Temperature range	-40°C to +140°C	-55°C to 105°C (THV up to 125°C)	-55°C to +105°C	-55°C to +105°C	-55°C to +125°C (+175°C For Specials)
IP rating	IP69k	Up to IP67	IP20	IP69k	Up to IP67 (Grommet-D & Environmental-D)
Individual wire sealing	Yes	Yes (grommet)	No	Yes (grommet)	Available on Select Products
Cable jacket sealing	Yes	Yes	No	No	Available on Select Backshells/Hoods
Shell Material	Plastic	Zinc Alloy (TNM, THV)	No	-	Steel, Copper Alloy, Aluminum & Stainless Steel
Insert material	Plastic	Thermoplastic	Zinc Alloy (TM)	Thermoplastic	Thermoplastic
Conductive (200h)	No	No	Thermoplastic	No	No
Conductive (500h)	No	No	No	No	No
Non-conductive (500h)	No	No	No	No	No
Non-conductive (1000h)	No	No	No	No	No

### APPLICATIONS KEY

**INFRASTRUCTURE APPLICATIONS:** Braking Systems  | Detection, Measurement and Control  | Diagnostics  | Fire Wall  | Level Crossing  | Lighting  | Location System 

Wheel Slide Protection (WSP) 

**ROLLING STOCK APPLICATIONS:** Automatic Doors  | Battery Chargers  | Bogies  | Brake/Speed Sensors  | Converters/Inverters  | Data Communication  | Driver's Cabin 

Under Car  | Wipers 



## CUSTOM PRODUCTS

	CIR FIBER OPTIC	POWER PLATES	HTB	JUNCTION BOXES	JUMPER CABLES	FRCIR STAINLESS STEEL	FRCIR MARINE BRONZE	VA900
	veam	veam	veam	veam	veam	veam	veam	veam
APPLICATIONS								
GENERAL	Standards / Connector Specifications	VG95234 / MIL-DTL-5015 (where applicable)	n/a	VG95234 / MIL-DTL-5015 (where applicable)		VG95234 / MIL-DTL-5015 (where applicable)	VG95234 / MIL-DTL-5015 (where applicable)	VG95234 (where applicable)
	Fire & Smoke standards	UL 94 V0	EN 45545-2 NFF16101/102	ISO 834 - 1/REI 30		EN 45545-2 NFPA 130	EN 45545-2 NFPA 130	EN 45545-2 NF F 16-101/102
	RoHS and Reach	Yes/No (depending on plating)	Yes	Yes		Yes	Yes	Yes/No (depending on plating)
	Number of Circuits	2 to 12	2 to 4 poles	35 poles		1 to 159 pins	1 to 159 pins	1 (single pole)
ELECTRICAL	Max. Operating Voltage	n/a	Consult factory	900 Vac to 1250 Vdc		4200 Vdc to 3000 Vac	4200 Vdc to 3000 Vac	1800 Vdc
	Max. Dielectric Withstanding Voltage	n/a	9.6Kv	2800 Vac		7000 Vac rms	7000 Vac rms	5000 Vac
	Max. Current Rating	n/a	750A	41A		350A	350A	750A
	EMI/RFI shielding	n/a	No	Yes		Yes	Yes	Yes
CONTACTS	Wire range AWG	n/a	Consult factory	AWG 12		AWG 26 to AWG 4/0	AWG 26 to AWG 4/0	-
	Wire Range mm <sup>2</sup>	n/a	up to 240	2.5		0.15 to 120	0.15 to 120	95 to 240
	Contact plating	n/a	Silver	Gold		Gold / Silver	Gold / Silver	Silver
	Power and Signal Layouts	n/a	No	Yes		Yes	Yes	No
MECHANICAL	Contact Size	n/a	Special	12		20 to 4/0	20 to 4/0	Special
	Mating cycles (max.)	500	500	2000		2000	2000	500
	Max. shock resistance (g's)	50	50	50		50	50	50
	Max. vibration resistance	20g - 10 up to 2000Hz	20g - 2000Hz	20g - 10 up to 2000Hz	This product line is customized based on customer request. Consult factory	This product line is customized based on customer request. Consult factory	20g - 10 up to 2000Hz	20g - 10 up to 2000Hz
ENVIRONMENTAL	Mechanical coding	Yes	Yes	Yes		Yes	Yes	Yes
	Type of coupling	Bayonet / Thread	Screw or Latching	Bayonet		Bayonet	Bayonet	Bayonet
	Temperature range	-40°C to +100°C	-40°C to +100°C	-55°C to +180°C (800°C for 30')		-40°C to +125°C	-40°C to +125°C	-40°C to +100°C
	IP rating	IP67 (mated condition with appropriate accessories)	IP67 (mated condition with appropriate accessories)	IP67 (mated condition with appropriate accessories)		IP67 (mated condition with appropriate accessories)	IP67 (mated condition with appropriate accessories)	IP67 (mated condition with appropriate accessories)
RoHS SHELL PLATINGS	Individual wire sealing	No	No	No		Yes	Yes	No
	Cable jacket sealing	Yes	Yes	Yes		Yes	Yes	Yes
	Shell Material	Aluminum	Aluminum	Stainless steel		Stainless steel	Marine Bronze	Aluminum/Stainless steel/Marine bronze
	Insert material	Thermoplastic / Metal	Thermoplastic	Ceramic (grommet silicone)		Flame retardant rubber	Flame retardant rubber	Thermoplastic
RoHS SHELL PLATINGS	Conductive (200h)	Yes	Yes	No		No	No	Yes
	Conductive (500h)	Yes	Yes	No		No	No	Yes
	Non-conductive (500h)	Yes	Yes	No		No	No	Yes
	Non-conductive (1000h)	Yes	Yes	No		No	No	Yes

Designed for speeds up to 400 km/h, this European VHS train counts on ITT Veam to connect passengers to a ride of comfort.



Veam FRCIR M12

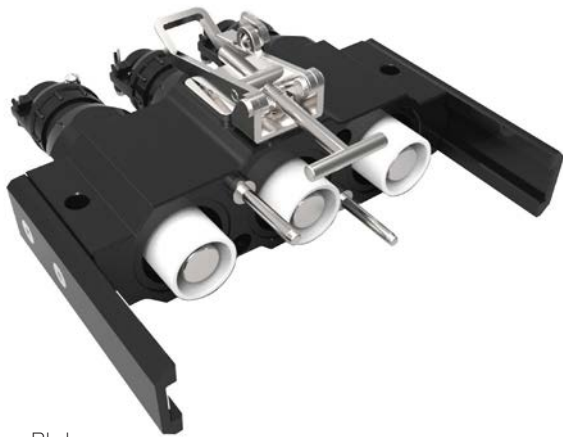

Veam Power Plate

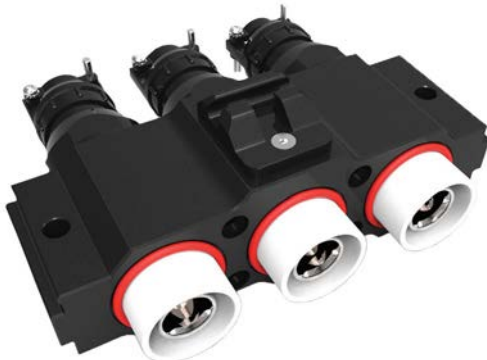

Operating 24 hours a day, 365 days of the year, ITT Veam helps this North American transit system deliver 2 billion rides a year.

Elevated rapid transit systems from Canada to Malaysia count on ITT Veam to keep the people flowing.

Serving 25 million passengers a year, ITT Veam provides this European regional rail system with the reliability and durability they need.



Veam CIR with Blue Generation plating

Linking the commercial hubs of central and southern China, ITT Veam helps this high speed line keep the passengers moving.



# We Connect

the future of rail

As a leading innovator of interconnect solutions for the rail industry, we continue to blaze trails with the newest technology. Now and into the future we will connect when it matters most.



Connect with your ITT Veam and Cannon representative today  
or visit us at [www.ittcannon.com](http://www.ittcannon.com)

# Connect with the rail experts

ITT's Veam and Cannon brands are world leaders in the design and manufacture of highly engineered connector solutions for the rail market.



ENGINEERED FOR LIFE

#### North America

56 Technology Drive  
Irvine, CA 92618  
Phone: +1.800.854.3028

#### Europe

Italy  
Corso Europa 41/43  
20020 Lainate (MI) Italy  
Phone: +39.02938721

Germany  
Cannonstrasse 1  
71384 Weinstadt, Germany  
Phone: +49.7151.699.0

#### Asia

Tuopandun Industrial Area, Jinda Cheng,  
Xiner Village, Shajing Town, Boan District,  
Shenzhen City, Guangdong Province, China 518215  
Phone: +86.755.2726.7888