



Belden® Rack and Cabinet Systems Catalog



Our End-to-End Expertise
Your End-to-End Solution

Racks and Cabinets
Cable Management
Airflow Management
Cabinet Power Distribution Units
Monitoring (Power, Environment, Access)

BELDEN



Belden — the most trusted brand for reliable signal transmission solutions — offers a complete selection of racking, cabinets, power distribution units, monitoring and airflow management products to meet your infrastructure needs for optimizing system performance.

Faster.
Easier.
Better.

Belden Infrastructure Solutions

Today's Data Center, Broadcast, AV and Security professionals must ensure that their infrastructure is highly available, scalable and flexible, while at the same time control operating expenses. These conflicting objectives have drawn attention to the performance of physical infrastructure elements, including heating and cooling, rack-level power, bandwidth and physical security management – all of which impact infrastructure availability, and therefore, mission critical applications.

Belden understands the issues you face daily – cooling, power, density and security – and can help you capitalize on these opportunities by implementing the right blend of technologies to maximize the efficiency of your enterprise in a manner that complements your system's performance requirements – today and into the future.

Table of Contents

Introduction	3–11	Section 3 — Components and Accessories	65–70
Belden Infrastructure Solutions	3	Cabinet Shelves	66
Application Guide for Belden Cabinets	4	Horizontal Cable Management	67
Product Summary and Selection Guide	5	Light Kits	68
Unique Offerings From Belden	6–7	Filler Panels	68
World-Class Cabinets	8	Grounding and Bonding	69
Features and Benefits of Belden Cabinets	9	Mounting and Adjoining Hardware	69
Customized Racks and Cabinets	10	Cabinet Access Systems	70
How to Use the Ordering Matrix	11	Section 4 — Power Distribution and Climate Monitoring	71–80
Section 1 — Racks and Cabinets	12–49	Cabinet Power Distribution Units (PDUs)	72–73
XHM Multi-Media, Server Cabinets	13–15	Single-Phase Basic/Smart PDUs	74
XHS Server, Networking and Switch Cabinets	16–19	3-Phase Basic/Smart PDUs	75
XHM, XHS Series - Cable Management and Zero U patching	20–21	Single- and 3-Phase Switched PDUs	76
XN Series — Open frame Networking and Switch Cabinets	22–26	PDU Accessories — Mounting, Cord Management and Cord Set	77
Seismic Cabinets	27–30	PDU Configuration Guide	78
Heat Containment Systems	31–36	Plug and Receptacle Configuration Chart	79
XNM Series — NEMA-12 Cabinets	37–38	Environmental Monitors and Sensors	80
CH Series	39–40	Section 5 — Warranty and Shipping Policy	81
XWM Series— Wall Mount Cabinets	40–41	Section 6 — Part Number Index	82–83
SecurePatch	42	Belden Rack and Cabinet Manufacturing	83
2- and 4-Post Distribution Rack Systems	43–47	Customer Service and other Belden Contacts	Back Cover
XWR and XWB Series— Wall Mount Racks	48		
XSW Series— Swing Racks	49		
Section 2 — Broadcast Racks and Cabinets	50–64		
Advantages	50–53		
Comparison Chart	53		
XSF Series — Slim Frame for Mobile Broadcast/Telecom Applications	54–55		
XMF Series — Media Frame for Broadcast Applications	56–58		
XME Series — Media Cabinet for Broadcast, Audio Video and Security Applications	59–61		
XMER Series — Media Cabinet for Broadcast, Audio Video, Security and Head End Applications	62–64		

Application Guide for Belden Cabinets

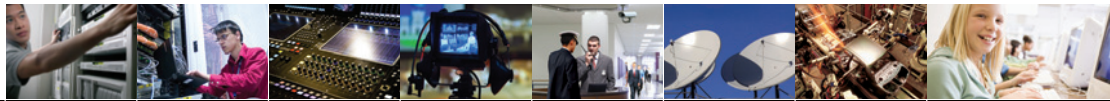

Rack or Cabinet Style	Page Number	Enterprise Networking	Data Center/Telco	Broadcast	Audio Video	Security	Cable TV, Head End	Harsh Environment, Networking	General Purpose, Retail, Office, K-12, House of Worship, etc.
XHM	13	●	●		●	●	●		■
XHS	16	●	●						
XN	22	●	●						
XSS/XSN*	27	●	●						
Passive/Active Containment	31	■	●						
XNM**	35							●	
CH Series	37	■	■		●	●			●
XWM	39	●			●	●			●
XDR	43	●	●	●					●
XWR/XWB	46	●							●
XSW	47	●							●
XSF	52			●					
XMF	54			●					
XME	57			●	●	●	●		●
XMER	60			●	●	●	●		●
PDU	69	●	●	●	●	●	●	●	●

● = Primary Application

■ = Secondary Application

* Seismic certified cabinets.

** Production floor networking equipment hosting.

Engineered to meet your specific needs.

Belden has leveraged its engineering and manufacturing expertise to bring you the most reliable cable, connectivity, cabinet and active systems solutions available – with the largest selection of products and the industry's most trusted technical support and service.

This catalog of Infrastructure Solutions products reflects the same quality and reliability you've come to expect from Belden for the housing and storage of data, broadcast, security and other equipment. Engineered for optimal cable routing, ease of

installation and maximum convenience, Belden racks and cabinets have also been designed to match the unique requirements of various industries and applications.

This table will help you select the Belden rack and cabinet family that best suits your specific application. If you need a custom design for a special application, please call us for assistance. Our Cable Management teams have many years of experience in modifying and customizing cabinet designs to suit many different requirements.

Faster.
Easier.
Better.

Product Summary and Selection Guide

Infrastructure Product Family	Rack or Cabinet Style	Page Number	Application	Rack Unit	Width	Depth	Height	Equipment Mounting
Free Standing Modular Cabinets	XHM	13	Multi-Media and Server Cabinet	42, 45, 48RU	24", 30"	30", 36", 42", 48"	78.62", 83.87", 90"	19"
	XHS	16	Server, Networking and Switch Cabinets	42, 45, 48RU	30", 40"	42", 48"	78.62", 83.87", 90"	19"
	XN	22	Open frame Networking and Switch Cabinets	42, 45, 48RU	30"	42", 48"	78.8", 84", 89.3"	19"
	XSS	27	Seismic Server Cabinet	45RU	24", 30"	48"	84"	19"
	XSN	27	Seismic Switch/Networking Cabinet	45RU	30", 40"	48"	84"	19"
	XNM	35	NEMA 12 Cabinet	45RU	29"	40"	84"	19"
	CH Series	37	Multi-Purpose Cabinets	42RU	23.6" or 31.5"	42.9", 50.8"	78.3", 83.5"	19"
	XSF	52	Mobile Broadcast Cabinet	10–48RU	19.2"	18", 24", 30"	20.5" to 87" (14 height options)	19"
	XMF	54	Broadcast Cabinets	11–57RU	22"	24", 30", 36", 40"	22.3" to 103" (26 height options)	19"
	XME	57	Multi-Media Cabinet (fixed sides)	24–44RU	22"	20", 26.5"	48.9" to 83.9" (4 height options)	19"
	XMER	60	Multi-Media Cabinet (removable sides)	24–44RU	22"	26.5", 31.5", 36"	48.9" to 83.9" (4 height options)	19"
Wall Mount Cabinets	XWM	39	Multi-Purpose Wall Mount Cabinets	9, 12, 20RU	21", 23"	22.9", 27.5"	20.1", 25.3", 39.3"	19"
Distribution Racks	XDR	41	Distribution Rack – 2 Post	45RU	20.3"	15"	84"	19"
	XDRS	41	Distribution Rack – 2 Post (steel), Zone 4 Seismic Rated	44RU	24"	15"	84"	19"
	BHRR	41	Distribution Rack – 2 Post (aluminum)	45RU	20.3"	15"	84"	19"
	XDR	41	Server Rack – 4 Post	45RU	20.3"	40", 44", 48"	84"	19"
	XSW	47	Swing Rack	43RU	34.4"	15"	84"	19"
	XWR	46	Wall Mount Rack – Swing Out	19, 26RU	19.8"	18"	36", 48"	19"
	XWR/XWB	46	Wall Mount Rack – Hinged	2, 4, 6RU	19", 19.5"	4", 9.5"	3.5", 7", 11"	19"



Unique Offerings From Belden

Belden End-to-End Infrastructure Solutions

Whether you're considering Belden racks and cabinets for use in a Data Center, Broadcast Studio, Commercial Enterprise, Industrial Facility or other application, it's important to look at the big picture. Chances are, you're managing a dynamic environment with evolving systems, technologies, logical architectures and new business models. You need to ensure that your infrastructure is highly available, scalable and flexible, while at the same time, control your operating expenses.

Manage Conflicting Objectives

These often conflicting objectives focus attention on the performance of physical infrastructure elements, including heating and cooling, rack-level power, bandwidth and physical security management. The challenge is that these elements typically tend to work against each other. For example, as load is increased with high-density active equipment, the system's power and cooling requirements are increased, and so are energy costs. Because these issues are directly interrelated, complications can arise from each system being manufactured, installed and supported by different vendors. That's why a systems approach for cost-effectively cooling, managing use of power and optimizing use of available space is critical.

Belden Can Help

We optimize cooling, power and density opportunities because we have expertise in all three areas, offering solutions that effectively deal with all three at the rack/cabinet level.

Belden Offers:

- Airflow, power distribution and power- and climate-monitoring devices that effectively help with high-density computing environments
- High-density racks, cabinets, copper and optical fiber cabling system components and cable management solutions that enable maximum bandwidth and availability in an efficient footprint for better air flow and optimal use of real estate

Advantages of Belden End-to-End Infrastructure Solutions

- Greater convenience of entire solution from a single source
- Assurance that all components work together
- The most reliable product performance in the industry
- Dependable service and superior support
- The most trusted name in the industry with a large global sales and distribution network

Delivering **complete infrastructure solutions** to maximize efficiencies.

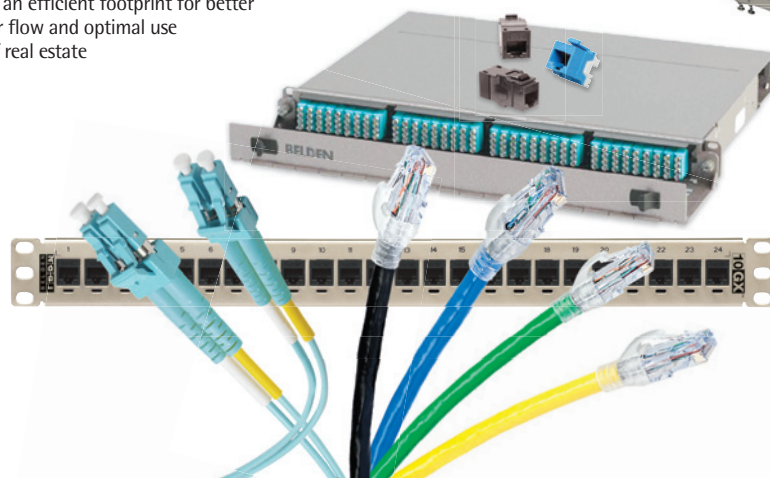

Faster.
Easier.
Better.



Unique Offerings From Belden

Data Center Ready Solutions

Data Centers require adequate planning to address equipment hosting, power and thermal management. Once active equipment has been chosen, the next step is to make sure you have the infrastructure to support the availability and performance your active equipment needs to deliver. Belden's dedicated engineering and manufacturing resources will design, build and deliver cabinets that support and optimize the performance of your selected active equipment. The result is a turnkey solution — from design to roll-out — on the Data Center floor. This service takes 100% of the guesswork out of the design process, making it ideal for Data Center designers, consultants, system integrators, facility planners and managers.



Optimized Integration

- Single-source physical infrastructure solutions designed to work together to support the optimal performance of the selected active equipment
- Pre-configured equipment hosting solution with optimal mix of fiber and copper connectivity, cable managers and power distribution units (PDUs), along with airflow management for heat containment

Reduction of Deployment Time and Cost

- Pre-configured, design-validated and labeled cabinets ready to receive servers or switches at the specific data center location (as per the assigned label)
- Use of best-in-class pre-terminated fiber and copper systems, smart PDUs and active heat containment for fast deployment and reduced labor costs

Streamlined Logistics

- Simplified coordination of all equipment hosting-related tasks — all passive components arrive pre-installed
- Designs can be templated, saved, duplicated and modified for future use

Ease of Standardization

- Single part number ordering for fully configured solution enables easy standardization, specification, ordering and simplified supply-chain hurdles
- Control of deployment methodology across single or multiple sites

Greening of Deployment

- Configured components are pre-installed to specific requirements, eliminating the need for individual packaging, thereby reducing waste disposal of cartons, boxes and plastics
- Consolidated shipping allows efficient packaging and a reduction in the CO₂ footprint

Contact Belden Today

Belden engineers are ready to work with you to design your Data Center Ready Solution. Contact us now to start the process of delivering the optimal support environment for your active equipment.

Designing the **optimal support environment** for your active equipment.

World-Class Cabinets



Belden's broad portfolio of cabinets for hosting servers, switch and networking equipment in Enterprise, Data Center and Broadcast applications is based on proven concepts and products. Each cabinet is built to meet specific application and customer needs. The modular approach and pre-configured capabilities of our cabinets enable fast installation of IT equipment with cable and connectivity management, while providing options for bandwidth scalability, secure features and power and air-flow management.

Key Features and Benefits of structural elements, security components, air flow dynamics and cable and power management are depicted in the value triangle below.

An **engineered, modular approach** enables Belden to meet your specific needs — quickly and effectively.

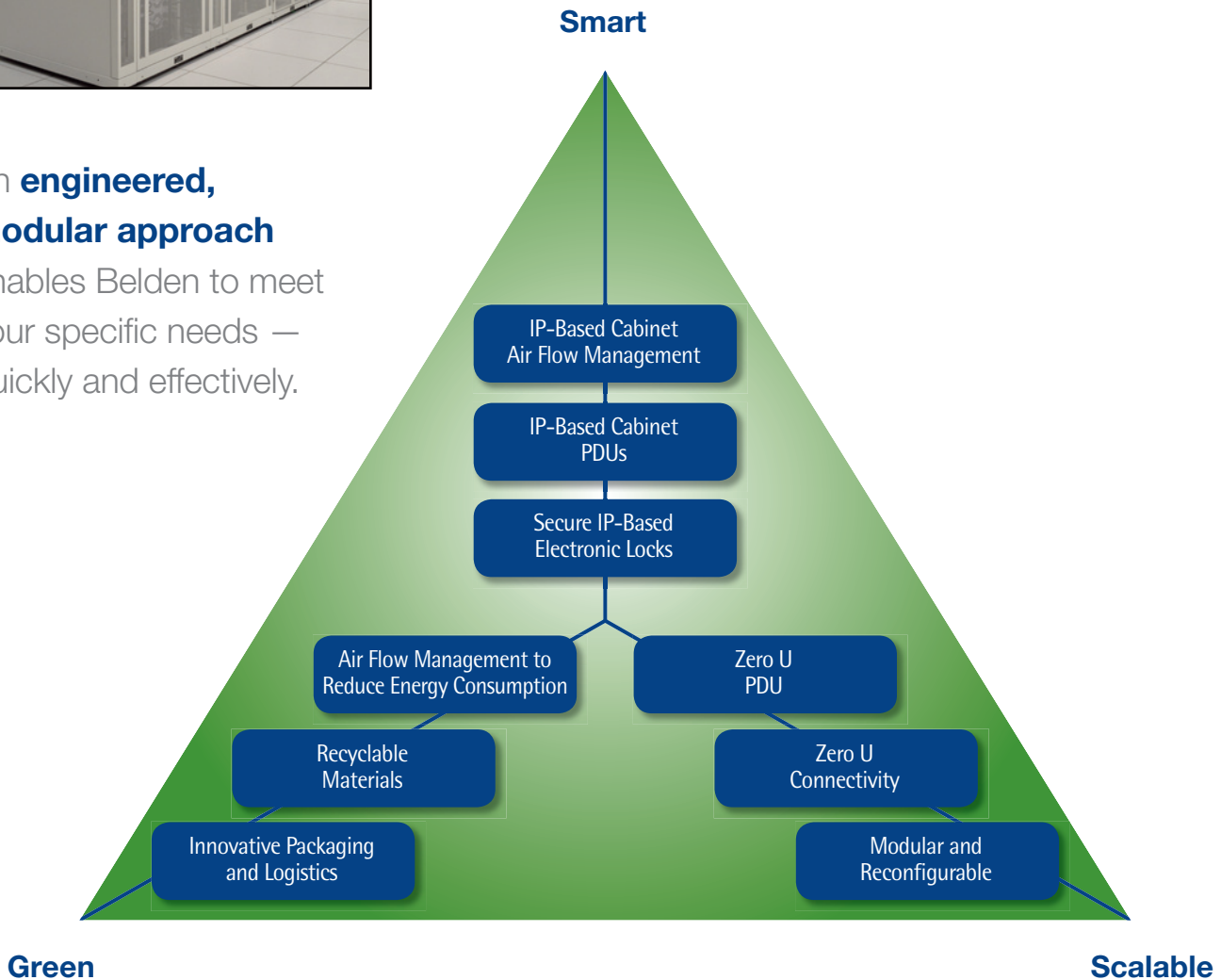

Faster.
Easier.
Better.

Features and Benefits of Belden Cabinets

Load Capacity

As Data Centers increase in density and bandwidth with blade servers and high port count switches, the need for higher load capacity cabinets is a growing trend. Most Belden cabinets have welded frame construction to accommodate static loads up to 3,000 lbs

To accommodate flexibility in data centers during the initial installation, the cabinets come with casters rated to dynamic loads up to 2,250 lbs

Modularity

A modular cabinet design accommodates frame widths from 22" to 40", heights from 42RU to 52RU and depths from 30" to 48" — all while ensuring cable management, power components and air flow management work seamlessly across the different sizes. This modular approach enables field-upgradable changes to chimney containment systems, PDUs and cable management.



Scalability

With Zero U mounting options, fiber and copper connectivity in the cabinets is scalable to address multiple-generation connectivity needs for servers and switches. Similarly, a broad portfolio of rack PDU offerings, from basic to 3-phase remote switched products, enables cabinets to support power requirements of multiple-generation active IT gear.



Adaptability

A selection of vertical and horizontal cable managers capable of handling a wide range of cable and connectivity density can be accommodated in the cabinets. The doors are field reversible with lift-off hinges.

In addition, the doors, top and bottom panels are configurable based on heat management needs for hot-aisle/cold-aisle configuration or chimney containment.



Security and Intelligence

Cabinets can be configured with a key access or smart access system with lock control at the cabinet level or end-of-row POD level.



IP-based air flow management and environmental monitoring-alarming systems and sensors for maximum availability.



Wide selection of smart PDUs with power monitoring and switching options for optimized power management and PUE measurement.



Environmental and Seismic

Belden's seismic cabinets are designed to pass Zone 4 Telcordia and/or NEB requirements in seismic zones, thus offering a stable working base for servers and switches. Similarly, the NEMA cabinets can accommodate factory floor or other harsh-environment equipment hosting requirements.



High Capacity Hosting

- Door designed to provide low resistance to air flow passage.
- Use of hexagonal 78% open perforated patterns
- Door design to maximize perforated surface



Customized Racks and Cabinets to Meet the Unique Needs of Your Installation

In-House Design, Prototyping and Manufacturing

Belden's in-house engineering and state-of-the-art sheet-metal fabrication, powder-coating and silk-screening capabilities enables racks and cabinets production from raw materials to finished goods. This gives unequalled agility to quickly develop – and deliver – technically sound, cost-competitive and compromise-free custom solutions to meet the challenges of your specific project.



Cellular-Based Manufacturing for Fast, Flexible Service

- Customer communicates project needs, goals and challenges directly to Belden design team
- Customization available for quantities as low as ten cabinets
- Quick-turnaround service – only 4–6 weeks from concept to delivery

Varying Levels of Customization to Meet Your Needs

- Custom paint color matching and silk-screened logos
- Ability to modify standard cabinet frame sizes
- Complete design/build of project-specific cabinets in steel, aluminum or stainless steel

Value Added Services Typically Performed for Customers

- NEMA-style cabinets for industrial networking and outdoor networking applications
- Kitting of racks or cabinets equipped with Belden and/or other manufacturers' components to enable quick and easy logistics and deployment in applications like retail POS
- Integration of power, cable management, connectivity, cooling and climate monitoring systems into cabinets
- Cabinets designed for heat containment with ducting to support high-bandwidth blade servers and switches
- Rack power distribution unit (PDU) customization for specific numbers of receptacles, single- and three-phase power and special overlays to enhance user experience
- Chimney containment customization to accommodate varying ceiling heights with options of passive or active sensors and fan-based units



Unequaled agility to develop and deliver **compromise-free custom solutions.**



Faster.
Easier.
Better.

How to Use the Ordering Matrix

Building a SmartPart Number

There are SmartPart ordering matrixes throughout this catalog that allow you to build part numbers for cabinets, options and accessories to meet your individual specifications. To build a part number, you simply choose from the options listed in the light blue boxes. The example shown below is for a cabinet.

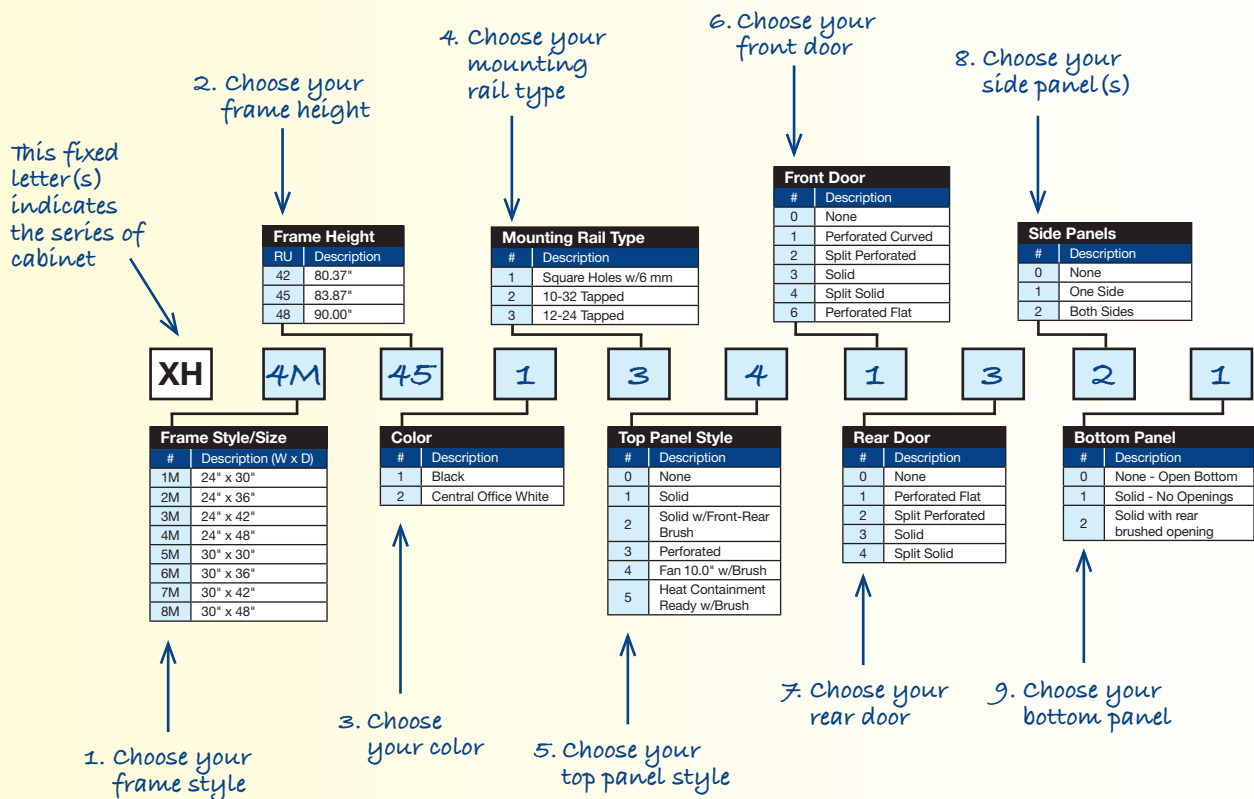

Final part number built to your specifications

XH4M451341321

By looking at the part number, you can tell that it's an XHM Series cabinet that's 24"W x 48"D x 83.87"H (45RU). It's black with 12-24 tapped mounting rails. The top panel has a 10" fan with brush for guiding cables into the cabinet. It also has a perforated curved front door, a solid rear door, side panels on each side and a solid bottom panel with no openings.



SECTION ONE

Racks and Cabinets

Table of Contents	Page
Racks and Cabinets	12-49
XHM Series — Multi-Media Cabinets	13-15
XHS Series — Server Cabinets	16-19
XHM Multi-Media, Server Cabinets	20
XHS Server, Networking and Switch Cabinets	21
XN Series — Open frame Networking and Switch Cabinets	22-26
Seismic Cabinets	27-30
Heat Containment Systems	31-36
XNM Series — NEMA-12 Cabinets	37-38
CH Series	39-40
XWM Series — Wall Mount Cabinets	40-41
SecurePatch	42
2- and 4-Post Distribution Rack Systems	43-47
XWR and XWB Series — Wall Mount Racks	48
XSW Series — Swing Racks	49



Specific Solutions for a Wide Array of Applications

As the premier supplier of cable and connectivity systems, Belden has leveraged its networking skills, engineering expertise and end-user experience to provide a broad portfolio of Racks and Cabinets that meet security, availability and efficiency challenges.

With the X Series (XHM, XHS, XN), Belden offers an cabinet solution that seamlessly integrates power distribution, airflow containment and management, networking connectivity and cable management to provide optimized hosting conditions for today's servers and switches. Designed to work seamlessly with Belden's market-leading fiber and copper connectivity solutions, the X Series vertical and horizontal cable management system supports high cabling/connectivity density, while providing ease of moves, adds and changes.

Shipped fully assembled and configured to exact end-user requirements, the X Series modular design includes a myriad of options for doors, side panels, airflow through passive chimneys or active AEHC units and PDU mounting for easy installation and reconfiguration. Single part number ordering permits ease of standardization and logistics.

Belden XHM (Server), XHS (Server, Networking) and XN (Networking) cabinets reduce Data Center operational costs by:

- Offering a modular and scalable system that adapts to changing requirements for hosting multiple generations of IT equipment
- Enabling seamless heat containment integration for reduced energy consumption
- Providing ganging compatibility for flexible arrangement in distributed, end-of-row or in-row switching environments
- Featuring a rigid yet light weight door design with an integrated punched hex pattern that offers an opening of 78% for superior air flow and a patent-pending hinge for maximum security and flexibility with a dual 270-degree swing.

Seamlessly integrate power distribution, air-flow containment and management, networking connectivity and **cable management** into one comprehensive cabinet solution — optimizing Data Center hosting conditions for servers and switches.

Faster.
Easier.
Better.

XHM Series – Multi-Media, Server Cabinets

Value-minded but versatile and feature-rich



Applications

With multiple cabinet footprints to better suit your space and application needs, the XHM Series is ideal for Security, Broadband, Enterprise Networking and Data Center applications. Its basic yet highly functional construction makes for a technically sound and economical cabinet system.

Design and Structural Features

- Perforated Door Mesh Opening: 78%
- Patent Secure Door Hinge: Dual 270-degree swing prevents aisle blocking for end-of-row cabinets
- UL 2416 Listed
- Frame Construction: Welded 16 and 14 gauge
- Fixture and Robotic welded for squareness (after frame construction)
- Mounting Rails Construction: 12 gauge, marked RU, RU 1 is at bottom of cabinet
- Static Load Capacity: 3,000 lbs
- Capacity on Casters: 580 lbs on regular capacity casters, 2,250 lbs with high-capacity casters
- EIA 310 Compliant: 19" mounting standard with optional 23" mount for 30" wide cabinets
- Vertical Cable Management Options
(See pages 20–21 for X Series Cabinet Accessories)
- Horizontal Cable Management Options
(See page 65 for Accessories)
- Tool-Less PDUs Mounting Options
(See pages 20, 75)
- Heat Containment Options
(See pages 31–34)
- Engineered and made in the USA

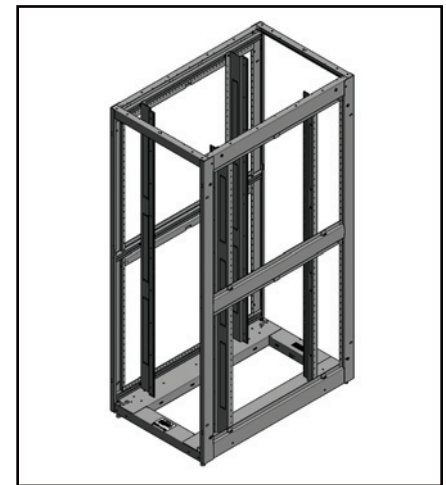
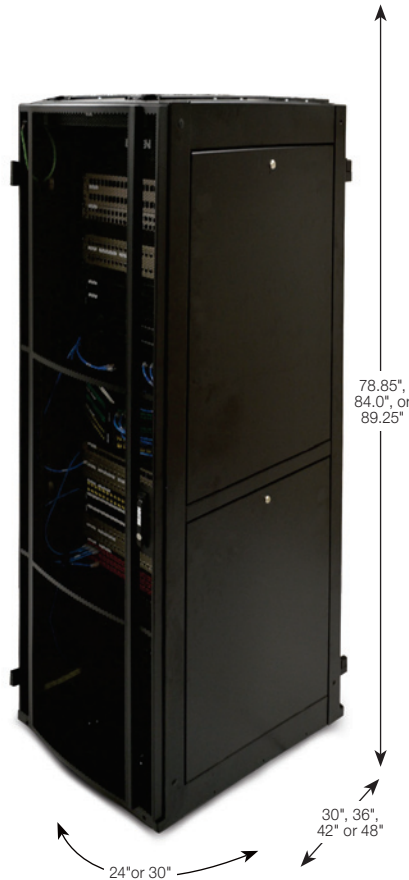

Part No. shown: XH7M451300000
(45RU x 30" W x 42" D)

24" Wide Cabinets

XHM Series Type	XH1M42	XH2M42	XH3M42	XH4M42	XH1M45	XH2M45	XH3M45	XH4M45	XH1M48	XH2M48	XH3M48	XH4M48
Dimensions: W x D x H (of Frame)	24" x 30" x 78.85"	24" x 36" x 78.85"	24" x 42" x 78.85"	24" x 48" x 78.85"	24" x 30" x 84.00"	24" x 36" x 84.00"	24" x 42" x 84.00"	24" x 48" x 84.00"	24" x 30" x 89.25"	24" x 36" x 89.25"	24" x 42" x 89.25"	24" x 48" x 89.25"
Available Mounting Rack Units (RU)	42RU				45RU				48RU			
Front Frame Opening (W x H)	21.25" x 73.85"				21.25" x 79.10"				21.25" x 84.35"			
Depth with Two Perf. Doors	33.75"	39.75"	45.75"	51.75"	33.75"	39.75"	45.75"	51.75"	33.75"	39.75"	45.75"	51.75"
Usable Depth (1)	28.75"	34.75"	40.75"	46.75"	28.75"	34.75"	40.75"	46.75"	28.75"	34.75"	40.75"	46.75"
Single Door Perforated Area	1365 sq. in.				1465 sq. in.				1565 sq. in.			

Note: (1) Standard Cabinet w/ curved perf front door & split perf rear door (2) Distance from front-most mounting rail face to inside of rear frame (3) Based on curved perf door

30" Wide Cabinets

XHM Series Type	XH5M42	XH6M42	XH7M42	XH8M42	XH5M45	XH6M45	XH7M45	XH8M45	XH5M48	XH6M48	XH7M48	XH8M48
Dimensions: W x D x H (of Frame)	30" x 30" x 78.85"	30" x 36" x 78.85"	30" x 42" x 78.85"	30" x 48" x 78.85"	30" x 30" x 84.00"	30" x 36" x 84.00"	30" x 42" x 84.00"	30" x 48" x 84.00"	30" x 30" x 89.25"	30" x 36" x 89.25"	30" x 42" x 89.25"	30" x 48" x 89.25"
Available Mounting Rack Units (RU)	42RU				45RU				48RU			
Front Frame Opening (W x H)	27.25" x 73.85"				27.25" x 79.10"				27.25" x 84.35"			
Depth with Two Perf. Doors	33.75"	39.75"	45.75"	51.75"	33.75"	39.75"	45.75"	51.75"	33.75"	39.75"	45.75"	51.75"
Usable Depth (1)	28.75"	34.75"	40.75"	46.75"	28.75"	34.75"	40.75"	46.75"	28.75"	34.75"	40.75"	46.75"
Single Door Perforated Area	1805 sq. in.				1935 sq. in.				2065 sq. in.			

Note: (1) Standard Cabinet w/ curved perf front door & split perf rear door (2) Distance from front-most mounting rail face to inside of rear frame (3) Based on curved perf door

Ordering Matrix for XHM Series

Part number example:

XH7M451311221

30"x42"x45RU black frame with casters and levelers, 12-24 tapped rails, solid top panel, perforated curved front door with lock handle, split perforated rear door with lock handle, two side panels with lock, solid bottom.

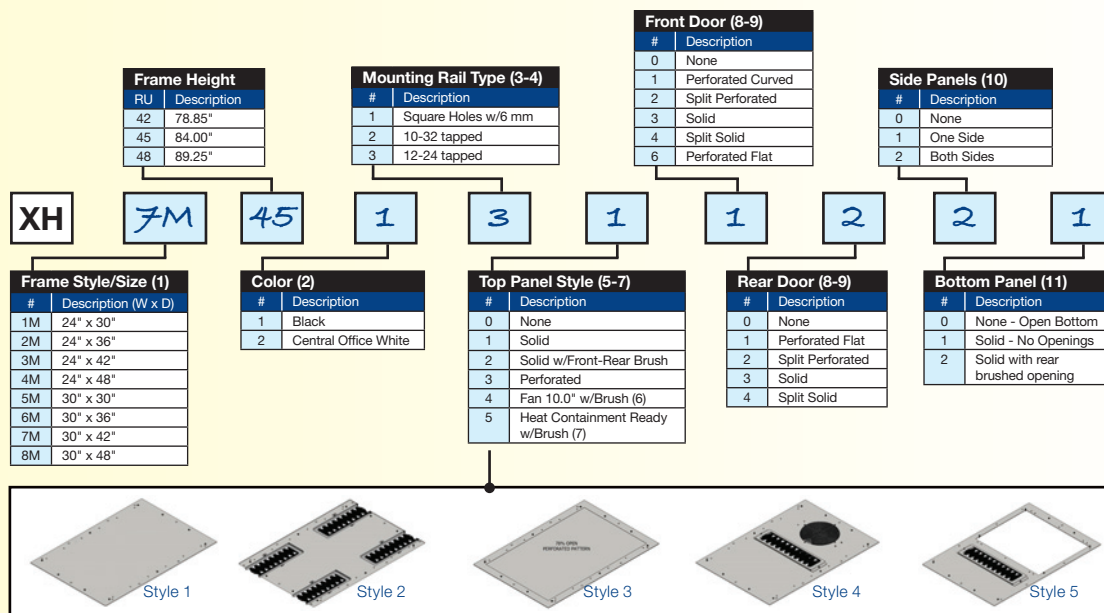

Notes:

- Frame includes casters, levelers, ganging hardware, grounding studs in frame base front/rear.
- Other colors and silk screening options available for volume orders.
- Includes 2 pair of 19" mount EIA rails (marked RU, 1 bottom) with mounting hardware (qty = 50). 6 mm hardware standard with square rails. 30" wide cabinet uses wide EIA rails featuring 3 removable knock out per rails. Brush frame for knock out to be ordered separately. Knock out compatible with zero mounting of standard 1U patch panel.
- Default front rail position 3.0" from cabinet face and 24" between rails for 30" and 36" deep, 30" between rails for 42" and 48" deep.
- Custom top panel available for volume orders.
- Fan top panel included, 10" dia., 550 CFM fan (120V).
- Heat containment top (42" and 48" deep only) ready to accept passive or active containment chimney.
- Front and rear doors include latching handle with key lock and bonding strap. Refer to Cabinet Access System Section for other access options.
- Single door swings left to right and is field reversible
- Side panel includes embossed key lock and bonding strap. Side panel made of a lower and upper panel. Side panel are flush, do not add width to cabinet and can be used as separator panel between cabinets.
- Bottom brush panel can be rotated 180° for choice of front or rear brush entry.

XHM Series – Individual Components Ordering Options

Cabinet Frame

Do not include rails, levelers and casters

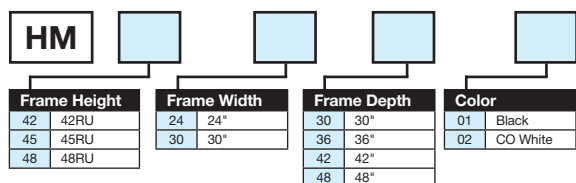

EIA Mounting Rails

Includes two pair of rails and mounting hardware (50). Default hardware for cage nut style rails is M6. Black only. EIA 23" mount available on custom request for 30" wide cabinet.

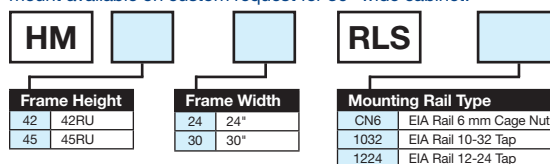

Faster.
Easier.
Better.



XHM Series – Options (continued)

Top Panel

Style 5 heat containment ready top panel only applicable to 42" and 48" deep cabinet.

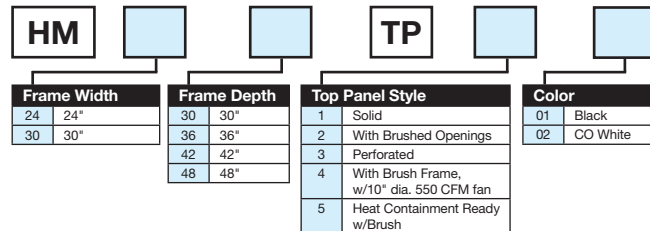

Side/Separator Panel

Side panel includes embossed key lock and bonding strap. Side panel made of a lower and upper panel. Side panel are flush, do not add width to cabinet and can be used as separator panel between cabinets.

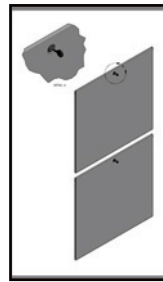
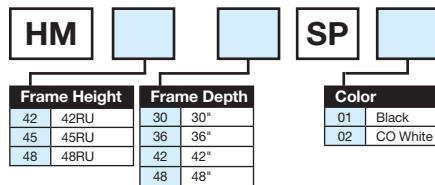

Side/Separator Panel with Lock

Door with Latch Lock Handle

Fan door single piece 940 CFM for 24" wide and split doors; 1880 CFM for 30" wide.

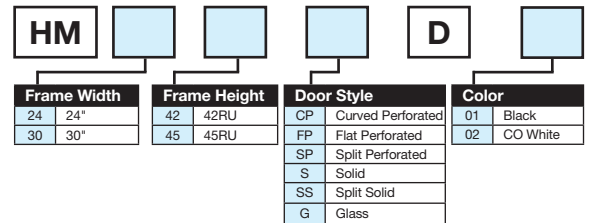

Cabinet Bottom Cover

When panel with brush is selected, will ship with brush in cabinet rear.

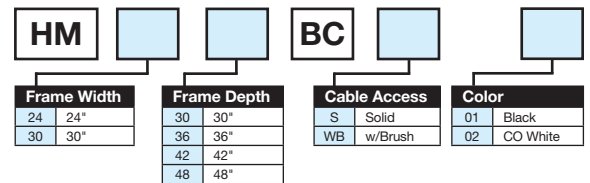

XHM Series – Accessories

Front to Rear Cable Manager

Adjustable-depth front to rear cable managers

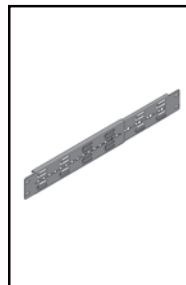
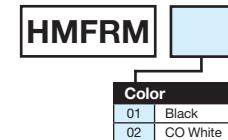

HMFRM

Front Rail Air Seal Kit

To be used when using passive or active containment chimneys. Rail seal kits are factory installed.

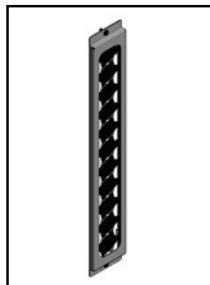
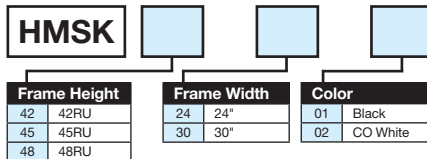

EIA rail cable pass through brush kit (1) for 30" wide XHM cabinet.

Cable Manager Fingers

Cable management fingers mount to EIA rails front and/or rear.

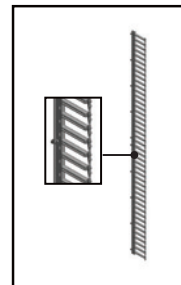
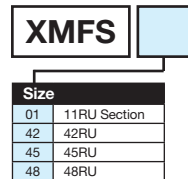

Fingers for Mounting Rails

Bottom Seal Skirt

Front and side skirt allow sealing below cabinets when on levelers.

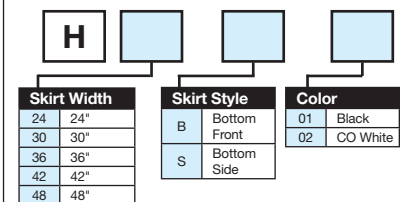

Top Cable Through with Cover

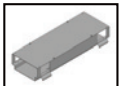
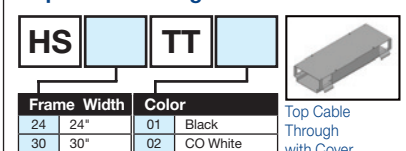

Top Cable Through with Cover (8.5" W x 4.0" H)



XHS Series – Server, Networking and Switch Cabinets

Supports high load capacities and proper air flow management



Part No. shown: XH1S451100000
(45RU H x 30" W x 42"D)



Part No. shown: X2S451121110 XHS Cabinet with optional Zeru U patch panel (30"W x 48"D x 45RU), rear view.



78.85",
84.0", or
89.25"

30" or 40"

42" or 48"

Aesthetics

- Designed and manufactured in the USA and fully customizable to meet specific equipment hosting challenges
- Available in Central Office white for improved internal visibility and reduced lighting needs
- 270-degree door swing means doors won't block aisles on end-of-row cabinets

Construction

- Welded 14-gauge frame and 11-gauge mounting rails support a static load of 3,000 pounds (2,250 pounds on high capacity casters) to host a full rack of blade servers
- Cabinets frames are fixtured and robotically welded for optimal squareness
- Rail seal and adaptive containment eliminate hot spots and provide energy efficiency, monitoring and alarming
- Designed and tested for use with Belden Fiber and Copper Networking solutions

Ease of Installation

- Modular design with options on doors, side panels, air flow management, cable management and PDU monitoring, offering ease of installation plus scalability
- Doors can be easily removed and oriented for left or right swing to suit application needs.
- Highly integrated and shipped fully assembled with power, air flow, connectivity and cable management
- Optimal physical density and networking bandwidth for ease of moves, adds and changes

Cable and Air-Flow Management

- XHS series cabinets are available in 30" and 40" wide version for optimal servers and switch hosting. Intake and exhaust duct options allowing side to side gears hosting.
- Integrated punched hex pattern is 78% open for low-resistance airflow through doors (legacy doors available upon request)
- Front rail seals enable physical separation of supply and return air for optimized hot/cold aisle and containment deployment
- 42" and 48" deep versions easily host deep equipment chassis with rear space for power and cable management
- Available in 42, 45 and 48RU for a variety of hosting requirements

Containment and Power Distribution

- Complete line up of IP-based power distribution units (PDUs) with available monitoring, alarming and receptacle-level switching
- Enables up to 30kW per cabinet with Belden's innovative passive and adaptive (AEHC) chimney-based containment systems

Faster.
Easier.
Better.



XHS Series – Server Cabinets (continued)

XHS Series Specifications

- Perforated Door Mesh Opening: 78%
- Patented Hinge Design: Secure, Dual 270-degree Swing
- UL 2416 Listed
- Frame Construction: Welded 14 gauge
- Fixtured and robotically welded for squareness
- Mounting Rails Construction: 11 gauge, marked RU, RU 1 is at bottom of cabinet
- Static Load Capacity: 3,000 lbs
- Capacity on Casters: 580 lbs on regular capacity casters, 2,250 lbs with high-capacity casters
- EIA 310 Compliant: 19" mounting
- Vertical Cable Management Options (See pages 20–21 for X Series Cabinet Accessories)
- Horizontal Cable Management Options (See page 65 for Accessories)
- Zero U – Vertical Patch Panel (See page 21)
- Tool Less PDUs Mounting Options (See pages 20, 75)
- Heat Containment Options (See pages 31–34)
- Engineered and made in the USA

30" Wide Cabinets

XHS Series Type	XH1S	XH2S	XH1S	XH2S	XH1S	XH2S
Available Mounting Rack Units (RU)	42RU		45RU		48RU	
Dimensions: W x D x H (of frame)	30" x 42" x 78.85"	30" x 48" x 78.85"	30" x 42" x 84.00"	30" x 48" x 84.00"	30" x 42" x 89.25"	30" x 48" x 89.25"
Front Frame Opening (W x H)	27.25" x 73.85"		27.25" x 79.10"		27.25" x 84.35"	
Depth w/ two Perf. Doors (1)	45.75"	51.75"	45.75"	51.75"	45.75"	51.75"
Usable Depth (2)	40.75"	46.75"	40.75"	46.75"	40.75"	46.75"
Single Door Perf Area (3)	1805 sq. in.		1935 sq. in.		2065 sq. in.	

Note: (1) Standard Cabinet w/ curved perf front door & split perf rear door (2) Distance from front-most mounting rail face to inside of rear frame (3) Based on curved perf door

40" Wide Cabinets

XHS Series Type	XH3S	XH4S	XH3S	XH4S	XH3S	XH4S
Available Mounting Rack Units (RU)	42RU		45RU		48RU	
Dimensions: W x D x H (of frame)	40" x 42" x 78.85"	40" x 48" x 78.85"	40" x 42" x 84.00"	40" x 48" x 84.00"	40" x 42" x 89.25"	40" x 48" x 89.25"
Front Frame Opening (W x H)	37.25" x 73.85"		37.25" x 79.10"		37.25" x 84.35"	
Depth w/ two Perf. Doors (1)	45.75"	51.75"	45.75"	51.75"	45.75"	51.75"
Usable Depth (2)	40.75"	46.75"	40.75"	46.75"	40.75"	46.75"
Single Door Perf Area (3)	2652 sq. in.		2782 sq. in.		2912 sq. in.	

Note: (1) Standard Cabinet w/ curved perf front door & split perf rear door (2) Distance from front-most mounting rail face to inside of rear frame (3) Based on curved perf door

XHS Series – Configured Cabinets

Belden will configure cabinets to your exact requirements. The following are commonly requested configured cabinets. Please contact your sales representative to discuss your specific needs.

Item	Part #	Frame Size			Color	Rails	Top Panel	Doors		Side Panel	Bottom Panel	Lacing/PDU Panel	Vertical Mngr.	
		Width	Depth	Height				Front	Rear				Fingers on Rail	Box Style Mngr.
1	XH1S45-C1000	30	42	45RU	Black	Square Rails	Brush Front/Rear	Perf.	Split Perf.	1 Solid	Open	2 x 3" + 2 x 7" Rear	No	No
2	XH2S45-C1000	30	48	45RU	Black	Square Rails	Brush Front/Rear	Perf.	Split Perf.	1 Solid	Open	2 x 7" Rear	No	Rear Rails
3	XH2S45-C1001	30	48	45RU	Black	Square Rails	Brush+Chimney Ready	Perf.	Split Solid	1 Solid	w/brush	2 x 7" Rear	No	Rear Rails
4	XH1S45-C2000	30	42	45RU	CO White	Square Rails	Brush Front/Rear	Perf.	Split Perf.	1 Solid	Open	2 x 3" + 2 x 7" Rear	No	No
5	XH2S45-C2000	30	48	45RU	CO White	Square Rails	Brush Front/Rear	Perf.	Split Perf.	1 Solid	Open	2 x 7" Rear	No	Rear Rails
6	XH2S45-C2001	30	48	45RU	CO White	Square Rails	Brush+Chimney Ready	Perf.	Split Solid	1 Solid	w/brush	2 x 7" Rear	No	Rear Rails

Ordering Matrix for XHS Series

Part number example:

XH1S451311221

30" x 42" x 45RU, black frame with casters and levers, 12-24 tapped rails, solid top, curved perforated front door with lock handle, split perforated rear door with locking handle, both side panels with locks, solid bottom.

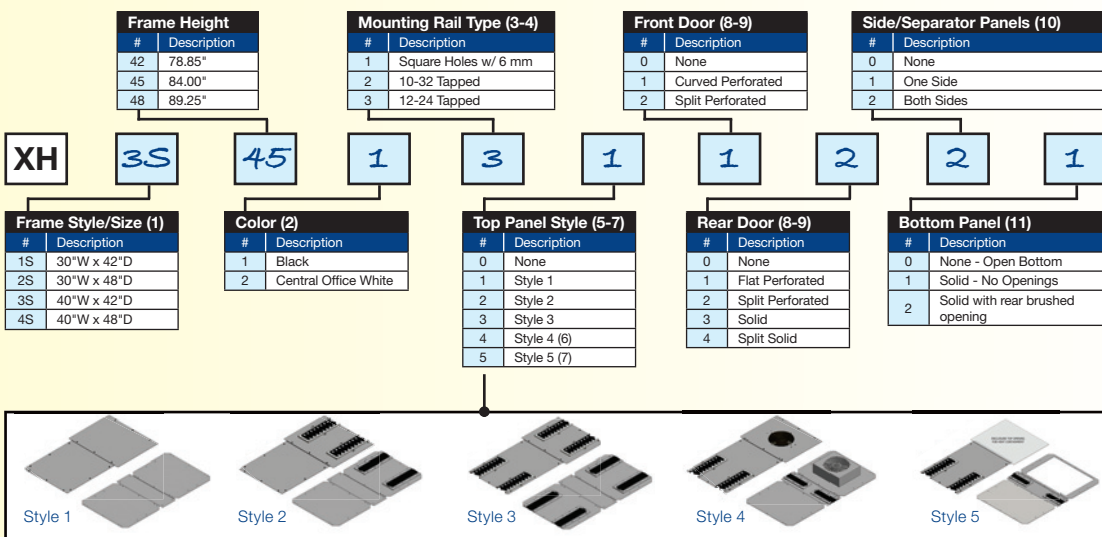

Notes:

- 1) Frame includes levers, ganging hardware, grounding studs in frame base front and rear.
- 2) Other colors and silk screening options available for volume orders.
- 3) Includes 2 pair of 19" mount EIA rails (marked RU, 1 at bottom) with mounting hardware (qty = 50). 6 mm hardware standard with square rails.
- 4) Default front rail position 3" from cabinet face and 30" between front and rear rails.
- 5) Custom top panel available for volume orders.
- 6) Fan top panel included, 10" dia., 550 CFM fan (120V).
- 7) Style 5 top ready to accept passive or active containment chimney.
- 8) Front and rear doors include latching handle with key lock and bonding strap. Refer to Cabinet Access System Section for other access options.
- 9) Single door swings left to right and is field reversible. Refer to Cabinet Access System Section for other access options.
- 10) Side panel includes embossed key lock and bonding strap. Side panel made of a lower and upper panel. Side panel are flush, do not add width to cabinet and can be used as separator panel between cabinets.
- 11) Bottom brush panel can be rotated 180° for choice of front or rear brush entry.

XHS Series – Individual Components Ordering Options

Top Panel Sections

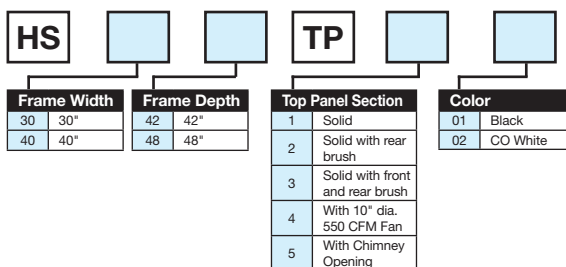

Side/Separator Panel

Side panel includes embossed key lock and bonding strap. Side panel made of a lower and upper panel. Side panel are flush, do not add width to cabinet and can be used as separator panel between cabinets.

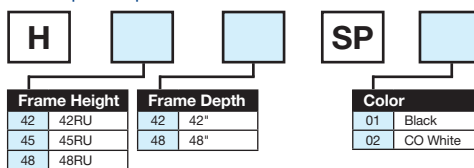

Faster.
Easier.
Better.



XHS Series – Options (continued)

EIA Mounting Rails

Includes two pair of rails and mounting hardware (50).
Default hardware for cage nut style rails is M6.

HS				RLS			
Frame Height		Frame Width		Mounting Rail Type			
42	42RU	30	30"	CN6	EIA Rail 6 mm Cage Nut		
45	45RU	40	40"	1032	EIA Rail 10-32 tap		
48	48RU			1224	EIA Rail 12-24 tap		

Door with Lock Latch Handle

HS						D			
Frame Width		Frame Height		Door Style				Color	
30	30"	42	42RU	CP	Curved Perforated			01	Black
40	40"	45	45RU	FP	Flat Perforated			02	CO White
		48	48RU	SP	Split Perforated				
				S	Solid				
				SS	Split Solid				

Cabinet Frame

Do not include rails, levelers and casters

HS							
Frame Style/Size		Frame Height		Color			
1S	30"W x 42"D	42	42RU	01	Black		
2S	30"W x 48"D	45	45RU	02	CO White		
3S	40"W x 42"D	48	48RU				
4S	40"W x 84"D						

Cabinet Bottom Cover

When panel with brush is selected, will ship with brush in cabinet rear.

HS				BC				
Frame Width		Frame Depth		Cable Access		Color		
30	30"	42	42"	S	Solid		01	Black
40	40"	48	48"	WB	w/Brush		02	CO White

Bottom Seal Skirt

Front and side skirt allow sealing below cabinets when on levelers.

H						S			
Skirt Width		Skirt Style		Color					
30	30"	B	Bottom Front		01	Black			
40	40"	S	Bottom Side		02	CO White			
42	42"								
48	48"								

XHS Series – Accessories

Front Rail Air Blocker

HS				RSK			
Frame Height		Frame Width		Color			
42	42RU	30	30"	01	Black		
45	45RU	40	40"	02	CO White		
48	48RU						

Front to Rear Cable Manager

Adjustable-depth front to rear cable managers

HSFRM			
Color			
01	Black		
02	CO White		



HSFRM

Finger Strip Kit

Cable management fingers mount to EIA rails front and/or rear.

*For One Rail

HSFS			
Frame Height		Quantity (for 1 rail)	
42	42RU	1	Front rail mount
45	45RU	2	Side rail mount
48	48RU		



Single Finger Manager

Other Accessories

Description	Belden Part Number
Front rail air blocker cable pass trough brush kit	
Brush kit (1) for rail air blocker, Black	HSRSBK01
Brush kit (1) for rail air blocker, White	HSRSBK02
40" Wide XHS cabinet top frame brush kit	
Brush Kit (1) for front knockout top, Black	HSTBK101
Brush Kit (1) for front knockout top, White	HSTBK102
Brush Kit (1) for middle knockout top, Black	HSTBK201
Brush Kit (1) for middle knockout top, White	HSTBK202
Brush Kit (1) for rear knockout top, Black	HSTBK301
Brush Kit (1) for rear knockout top, White	HSTBK302

Top Cable Through with Cover

HS				TT			
Frame Width		Color					
30	30"	01	Black				
40	40"	02	CO White				

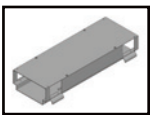

Top Cable Through with Cover (8.5" W x 4.0" H)



Lacing Panel (close-up)

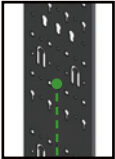

Vertical Lacing/PDU Mounting Panel 3.5" and 7" wide

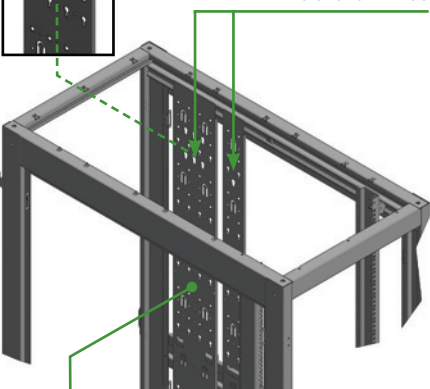

Lacing Panel shown in cabinet

Finger Style Vertical Manager

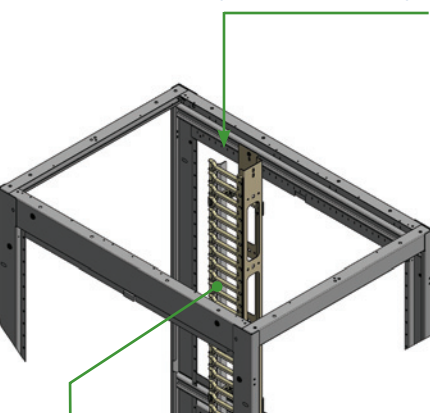

Vertical Manager shown in cabinet

Belden's XHM and XHS Series Cabinets – Cable Management and Zero U Patching

Belden's XHM and XHS Series cabinets and cable management components were specifically designed for integration with the Belden IBDN copper and fiber networking system for a true end-to-end solution.

The combination of Belden's extensive cable and connectivity design knowledge and years of interaction with installers and system designers has enabled us to offer:

Features

- A broad selection of modular vertical and horizontal cable managers in configurations that meet your exact requirement for compromise-free hosting
- Flexibility to meet customer needs requiring low to extremely high networking/hosting density
- Modular cable management components and cabinets that protect your investment because they can be reconfigured to meet evolving hosting requirements (typical cabinet system will play host to 3–5 generation active equipment)
- Vertical managers that enable ease of moves, adds and changes, making management of your network fast and precise while still allowing you to maintain an organized, consistent look
- A cable management system designed to maintain proper cable bend radius and minimal tension through the use of support fingers, an attachment point for cable bundles and a slack management spool, ensuring maximum bandwidth from your copper and fiber networks

See page 65 for Horizontal Cable Management options.

Vertical Lacing/PDU Mounting Panel*

- Manager panel 7" and 3.5" wide
- Mounts on rail struts for depth adjustability
- Panels can be mounted side by side to create manager surface
- Tool-less PDU mounting
- Lacing of cable bundles
- Attachment of ring managers
- Attachment of slack management spools
- Attachment of quick mount base

*Lacing-PDU mounting panels (p.21 and 75) are not included with the cabinets or the PDU's and need to be ordered separately. PDU's/panels uses tool less "button" style mounting.

Finger Style Vertical Managers

- Mounts on rail struts for depth adjustability
- Compatible with both 24" and 30" wide cabinets
- Can be used in cabinet front and rear
- Includes doors to hide cables and provide organized look
- Vertical manager can be oriented two different ways to optimize cable routing

Finger Style Features:

- 5.5" wide x 3.6" deep for 20 sq. in. of cross sectional area
- For medium- and high-density applications
- Management fingers align with mounting rail RU
- Finger allows for cable support and bend radius control
- Oblong opening allows cable routing into the manager

Faster.
Easier.
Better.

XHM and XHS Series – Accessories



Vertical Lacing/PDU Mounting Panel

HVMP			
Panel Width	Frame Height	Color	
01 3.5"	42 42RU	01	Black
02 7"	45 45RU	02	CO White
	48 48RU		

Vertical Manager – Finger Style

With door.

HVM	02		
Frame Height	Color		
42 42RU	01	Black	
45 45RU	02	CO White	
48 48RU			

Other Accessories

Description	Belden Part Number
Ring Kits	
Cable Management Ring Plastic (Qty = 5) 3" x 1.5" Reversible	XMR01
Cable Management Ring Kit (Qty = 5) 6.5" Wide x 3" Deep	XMR02
Cable Management Ring Kit (Qty = 5) 2.5" Wide x 3" Deep	XMR03
Fiber Slack Management Spools 6" deep (includes 2 spools)	BHSP020
Fiber Slack Management Spools 2" deep for lacing panels (includes 2 spools)	BHSP030
Quick Mount Base (Qty=10) includes Fastener, for 1/4" Holes	XTCM01
Velcro Cable Ties, 25 per Roll, 8"L	AX100783
Velcro Cable Ties, 25 per Roll, 12"L	AX100784
Vertical Ground Bars	
Vertical Ground Bar, Insulated, 42RU	HVGB0142
Vertical Ground Bar, Insulated, 45RU	HVGB0145
Vertical Ground Bar, Insulated, 48RU	HVGB0148
Miscellaneous	
Casters Kit (4), regular capacity 1080 lbs	XCK01
Casters Kit (4), high capacity 2250 lbs	XCK02
Levelers Kit (4)	XLK01
Bolt together kit for cabinets	8910-0100

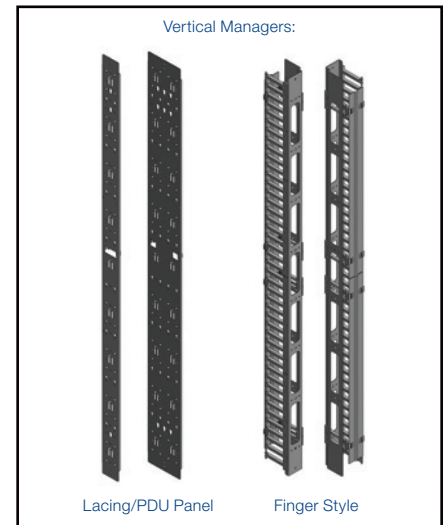

Zero U – Vertical Patch Panel and Connectivity

Features

- Attach to mounting rails
- Vertical patch panels are compatible with Belden copper and fiber connectivity (FX UHD, FX Ultra Frames and Cassettes)



Description	Belden Part Number
Zero U – Vertical Patch Panel and Connectivity	
Vertical Patch Panel (7 positions), Compatible with XHS Cabinets	XZUK01
Vertical Patch Panel (14 positions), Compatible with XHS Cabinets	XZUK02
FXUHD KeyConnect Frame Blank	FFZH00BB
FXUHD KeyConnect Frame 6-Port, Black (Empty)	FFZH06KC
FXUHD KeyConnect Frame 8-Port, Black (Empty)	FFZH08KC
10GX KeyConnect Couplers for Vertical Mount Patch Panel, 8-Port, Black	AX105366
CAT6+ KeyConnect Couplers for Vertical Mount Patch Panel, 8-Port, Black	AX105367

Belden Zero U - Vertical patch panel allows for optimal use of mounting space into XHS Series cabinets by providing high-density connectivity options along the equipment mounting rails.



XN Series – Networking and Switch Cabinets

Designed to handle dense patching fields while ensuring proper air flow

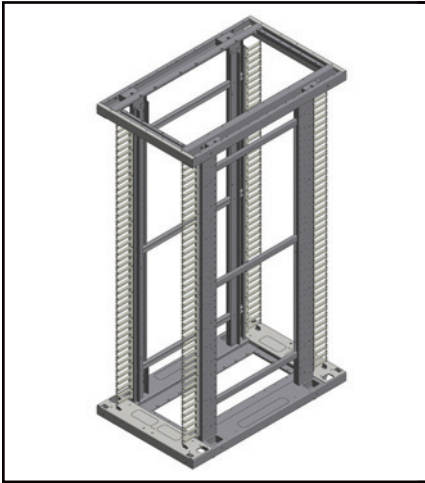

XN Series Frame Only

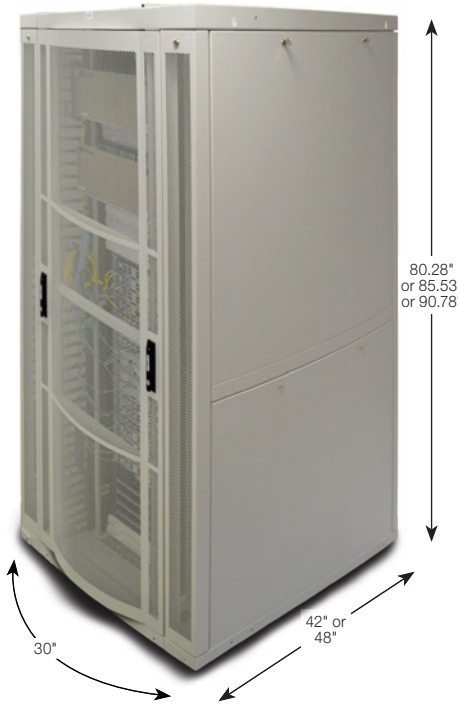

XN Series with 6" end-of-row extension

Features

- Modular cabinet designed for networking (cross connect) and switch hosting into Data Centers
- 30" wide cabinet, 42" or 48" deep with 42, 45 and 48 RU height options
- Unique open frame construction allows structural uprights to be positioned inside the frame, resulting in a corner post-free structure, enabling unobstructed access to front and rear vertical managers
- 6" cabinet extension can be mounted on each side of the 30" frame, resulting in a 42" frame for hosting of side-to-side venting switches
- Dual 270-degree swing prevents aisle blocking for end-of-row cabinets and optimizes access to right and left cable manager
- Doors feature 78% opened integrated hexagonal mesh for low air resistance and optimal cooling of the hosted gears (legacy doors available upon request)
- Integrated front and rear finger-style vertical managers
- Modular front-to-rear cable management options
- Vertical (Zero U) patch panel options, for integration of Belden pre-terminated copper and fiber connectivity products
- Front rail air seal and baffle for high level of separation between cold-supply air and hot-return air, ideal for high-density hosting
- Available in black and central office white

Containment Ready

- Fully compatible with passive or active (AEHC) chimney containment, up to 30kW of hosting capacity

Power Ready

- XN cabinets are ready to host high-end power distribution units from Belden's line up of smart PDUs

Switch Ready

- Switch-specific configuration includes air director for side-to-side venting switches (Ex: Cisco Catalyst 6509, Nexus 7018)

30" Wide Cabinets

XN Series Type	X3N42	X3N45	X3N48	X4N42	X4N45	X4N48
Dimensions: W x D x H (of Frame)	30" x 42" x 80.28"	30" x 42" x 85.53"	30" x 42" x 90.78"	30" x 48" x 80.28"	30" x 48" x 85.53"	30" x 48" x 90.78"
Available Mounting Rack Units (RU)	42	45	48	42	45	48
Front Frame Opening (W x H)	19.67" x 73.74"	19.67" x 78.99"	19.67" x 84.24"	19.67" x 73.74"	19.67" x 78.99"	19.67" x 84.24"
Depth with Doors	42"			48"		
Usable Depth (1)	27.42"			33.42"		
Single Door Perforated Area	1,278 sq. in.	1,375 sq. in.	1,472 sq. in.	1,278 sq. in.	1,375 sq. in.	1,472 sq. in.

Note:

(1) Distance from front-most mounting rail face to inside of rear frame.

Faster.
Easier.
Better.



XN Series — Networking and Switch Cabinets (continued)

XN Series Specifications

- Frame Construction: Welded
14 and 12 gauge
- Static Load Capacity: 3,000 lbs
- Capacity on Casters: 2,250 lbs
with high-capacity casters
- Engineered and made in the USA

XN cabinet frames
30"W x 48"D x 45RU

6" between cabinet
extension includes front
and rear removable panels

6" end-of-row extension
includes front and rear
removable panels and side panel

78% open hex patterned door
with patent-pending hinge design
that offers superior security and a
dual 270-degree swing

Optional air intake/exhaust
duct for hosting of side-
to-side venting switches

PDU mounting provision for
easy integration of Belden
high capacity smart PDUs

Corner-free frame allows
for optimal access to
integrated front and
rear vertical managers

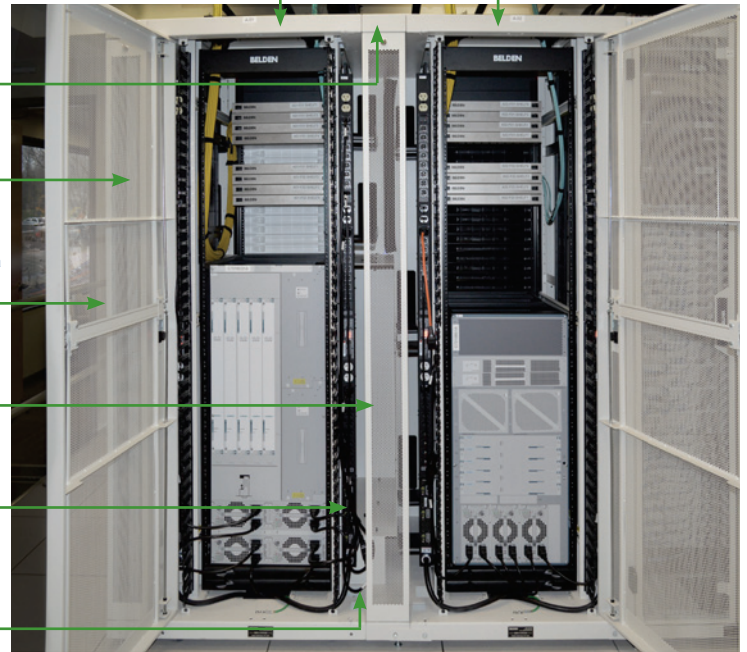

Ganged XN frames with end-of-row 6" extension and between cabinet 6" extension (rear view)

XN Series — Switch-Ready Configured Cabinets

Belden will configure cabinets to your exact requirements.
The following allows seamless hosting of switches from CISCO's Catalyst and Nexus Series.
Please contact your Belden sales representative to discuss your specific needs.

Item	Part #	Frame Size			Color*	Rails	Top Panel	Doors		Lacing/PDU Panel	Air Director Duct	6" Frame Ext.
		Width	Depth	Height				Front	Rear			
1	X4N45-C6509101	30	48	45RU	Black	Square Rails	Brush Front/Rear	Perf.	Split Perf.	2 Rear	(1) 6509	None
2	X4N45-C6509102	30	48	45RU	Black	Square Rails	Brush+Chimney Ready	Perf.	Split Solid	2 Rear	(1) 6509	None
3	X4N45-C6509103	30	48	45RU	Black	Square Rails	Brush Front/Rear	Perf.	Split Perf.	2 Rear	(2) 6509	None
4	X4N45-C6509104	30	48	45RU	Black	Square Rails	Brush+Chimney Ready	Perf.	Split Solid	2 Rear	(2) 6509	None
5	X4N45-C7009101	42	48	45RU	Black	Square Rails	Brush Front/Rear	Perf.	Split Perf.	2 Rear	7009	Left/Right Side
6	X4N45-C7009102	42	48	45RU	Black	Square Rails	Brush+Chimney Ready	Perf.	Split Solid	2 Rear	7009	Left/Right Side
7	X4N45-C7010101	30	48	45RU	Black	Square Rails	Brush Front/Rear	Perf.	Split Perf.	2 Rear	None	None
8	X4N45-C7010102	30	48	45RU	Black	Square Rails	Brush+Chimney Ready	Perf.	Split Solid	2 Rear	None	None
9	X4N45-C7018101	42	48	45RU	Black	Square Rails	Brush Front/Rear	Perf.	Split Perf.	2 Rear	7018	Left/Right Side
10	X4N45-C7018102	42	48	45RU	Black	Square Rails	Brush+Chimney Ready	Perf.	Split Solid	2 Rear	7018	Left/Right Side

* For Central Office White color, replace 1 with 2 (ex: X4N45-C7018201).

Notes:

- Switch-specific configuration includes all cabinet components needed to host given switch.
- Configuration 3 and 4 allows for hosting of two CISCO Catalyst Series 6509 per cabinet.
- Mounting Rails Construction: 11 gauge, marked RU, RU 1 is at bottom of cabinet.
- Power Distribution Units (PDUs) are not included in above configurations; refer to PDUs Section of the catalog (pgs. 69–76) for options.
- For "chimney-ready" configuration, refer to Containment Section of the catalog (pgs. 31–34) for chimney and accessories options.
- Bottom panel with rear brushes is included.
- Side panels (left and right) is included.
- 6" extension frame includes extension front and rear panels.
- Solid rear panel for chimney ready cabinets.

Ordering Matrix for XN Series

Part number example:

X3N45132523121

30"x42"x45RU black frame with casters and levelers, 12-24 tapped rails, top panel with rear brush, perforated front door with dual lock handle, split perforated rear door with lock handle, 6" end-of-row extension left, side panel on right, brushed baffles, solid bottom.

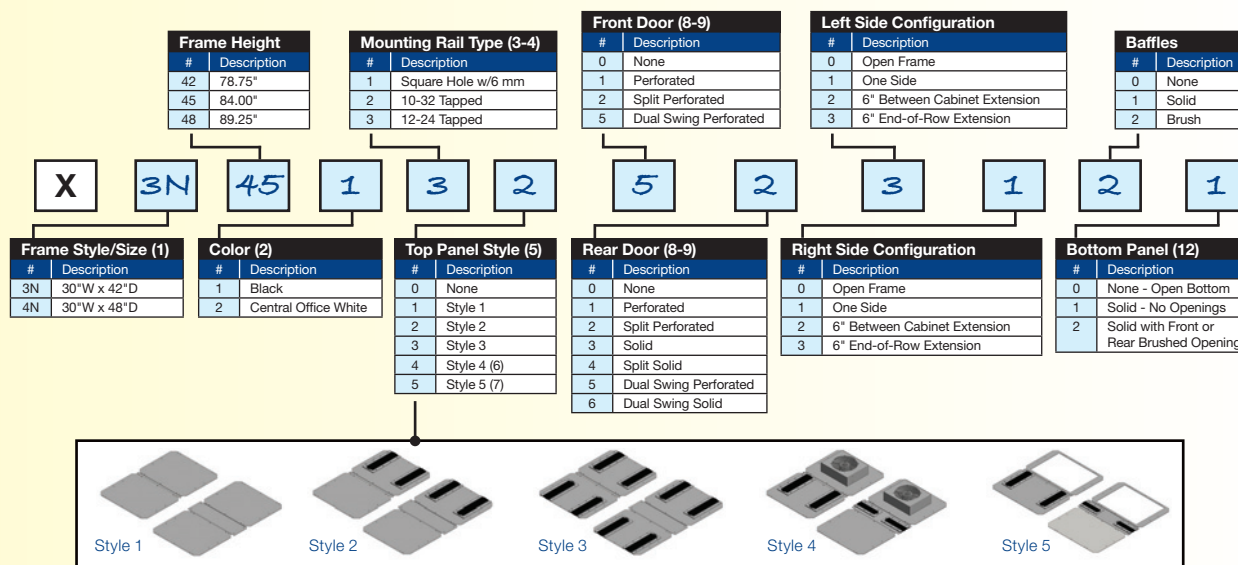

Notes:

- 1) Frame includes casters, levelers, ganging hardware, grounding studs in frame base front and rear.
- 2) Other colors and silk screening options available for volume orders.
- 3) Includes 2 pair of 19" mount EIA rails (marked RU, 1 at bottom) with mounting hardware (qty = 50). 6 mm hardware standard with square rails.
- 4) Default front rail position 3.81" from cabinet face and 30" between front and rear rails.
- 5) Custom top panel available for volume orders.
- 6) Fan top panel includes 10" dia. 550 CFM fan (120V).
- 7) Style 5 top panel to accept passive or active containment chimney.
- 8) Front and rear doors include latching handle with key lock and bonding strap.
- 9) Single door swings left to right and is field reversible.
- 10) Side panel includes two half-height panels with key lock and bounding strap. Panel does not add width to cabinet.
- 11) Side panels with brushes or perforated rear available from component selection.
- 12) Bottom brush panel can be rotated 180° for choice of front or rear brush entry.

XN Series – Individual Components Ordering Options

Door with Latch Lock Handle

When switching doors out, door adapter comes with door.

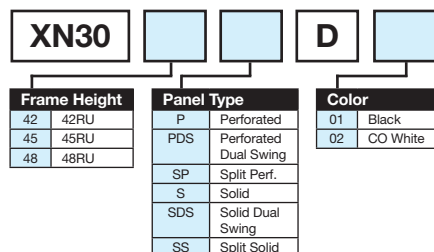

Side Extension Doors

Side Extension Panel with lock. Includes one panel (can be use front or rear).

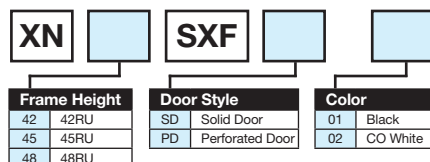

Top Panel Sections

Small section 5 and 6 only applicable to 48" deep cabinets. No panel required for chimney containment on cabinet.

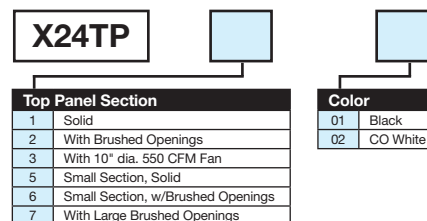

Faster.
Easier.
Better.



XN Series – Options (continued)

Cabinet Frame

No rails, levelers, and casters.

X		N		
Frame Depth		Frame Height		Color
3 42"		42 42RU		01 Black
4 48"		45 45RU		02 CO White
		48 48RU		

EIA Mounting Rails

Includes two pair of rails and mounting hardware (50). Default hardware for cage nut style rails is M6.

XN		30LRS	
Frame Height		Mounting Rail Type	
42 42RU		CN6 6 mm Cage Nut	
45 45RU		1032 10-32 Tap	
48 48RU		1224 12-24 Tap	

Cabinet Bottom Cover

When panel with brush is selected, will ship brush in cabinet rear.

XN24		BC		
Frame Depth		Panel Type		Color
42 42"		S Solid		01 Black
48 48"		WB w/Brush		02 CO White

Side and Extension Panel

Side panel mounted (default position) on right side facing cabinet front. Panel # includes bottom and top panels, mullion.

XN			SP		
Frame Height		Frame Depth	Side Panel Kit (2)		Color
42 42RU		42 42"	S w/Lock		01 Black
45 45RU		48 48"	PP w/Rear Perforation w/Lock		02 CO White
48 48RU			PB w/Front and Rear Brush w/Lock		

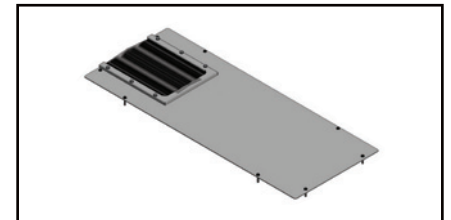

Cabinet Bottom Cover

XN Series – Accessories

Horizontal Managers

Horizontal manager waterfall attaches to horizontal manager bar.

XNFRM			
Frame Depth		Style	Color
42 42"		1 For Cabinet	01 Black
48 48"		F1 Waterfall	02 CO White

Horizontal Trough Managers

XNFRT		1	
Frame Depth		Color	
42 42"		01 Black	
48 48"		02 CO White	

Vertical Ground Bars

XVGB01	
Frame Height	
42 42RU	
45 45RU	
48 48RU	

Vertical Lacing Panel

Needs (3) horizontal manager bars for mounting.

XNVLP				
Frame Height		Frame Depth	Panel Width	Color
42 42RU		42 42"	1 3.5"	01 Black
45 45RU		48 48"	2 7.0"	02 CO White
48 48RU				

Side Extension Kits with Side Panel

Allows for 6" extension to cabinet, can be used on both sides. Front and rear panel not included.

XN		SXF4	
Frame Height		Frame Depth	Color
42 42RU		42 42"	01 Black
45 45RU		48 48"	02 CO White
48 48RU			

Between Cabinets Extension Kits

6" extension kits for bolting between two cabinets. Front and rear panel not included.

XN		SXF1	
Frame Depth		Color	
42 42"		01 Black	
48 48"		02 CO White	

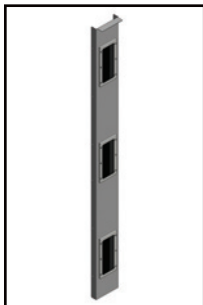

Seal Kit for ganged cabinets

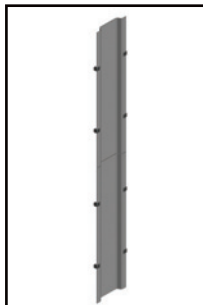

Vertical Door Kit

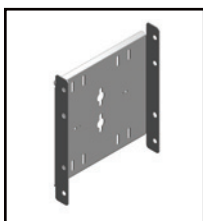

PDU Mounting Bracket (Single)

XN Series – Accessories (continued)

Seal Kit

Seal kit bolt through the front of two 30" frames to allow front-to-rear air separation.

XN			
	Frame Height	Seal Type	Color
42	42RU	SK	01 Black
45	45RU	SKB	02 CO White
48	48RU		

Vertical Door Kit

Mounts between two existing frames with fingers on the post.

XN		DK	
	Frame Height	Color	
42	42RU	01	Black
45	45RU	02	CO White
48	48RU		

Description	Belden Part Number
-------------	--------------------

Other Accessories

Front Air Baffle	
Air Baffle 45RU X 2.0" Wide, Single, Black	XN4530ADS0101
Air Baffle 45RU X 6.25" Wide, Single, Black	XN4530ADS0301
Air Baffle with Brush (3) 45RU X 6.25" Wide, Single, Black	XN4530ADS0401
Air Baffle 45RU X 2.0" Wide, Single, CO White	XN4530ADS0102
Air Baffle 45RU X 6.25" Wide, Single, CO White	XN4530ADS0302
Air Baffle with Brush (3) 45RU X 6.25" Wide, Single, CO White	XN4530ADS0402
Brush for Front Air Baffle	
Brush Kit 5.5"W x 11.5"H (1 per) for Front Air Baffle, Black Frame	XNSKB01
Brush Kit 5.5"W x 11.5"H (1 per) for Front Air Baffle, CO White Frame	XNSKB02
Finger Managers	
Finger Manager Kit Front Face Mount for 1 Rail, 42RU	XNFS42
Finger Manager Kit Front Face Mount for 1 Rail, 45RU	XNFS45
Finger Manager Kit Front Face Mount for 1 Rail, 48RU	XNFS48
Power Distribution Mounting Brackets	
PDU Mounting Bracket Double, Post Mounting 2 PDU Side-by-Side Facing into Cabinet	XNPM01
PDU Mounting Bracket Single, Rear Facing Pair	XNPM02
PDU Mounting Bracket Rear Facing Pair Between Frames	XNPM03
PDU Mounting Bracket Rear Facing Pair Between Frames with Extension	XNPM04
Slack Spool Management	
Slack Spool Management Plastic 5.0" (Qty = 2) Kit	BHSP020
Slack Spool Management Metal 2.5" (Qty = 2) Kit	BHSP030
Cable Management Accessories	
Cable Management Ring Plastic (Qty = 5) 3" x 1.5" Reversible (22991)	XMR01
Cable Management Ring Kit (Qty = 5) 6.5" Wide x 3" Deep	XMR02
Cable Management Ring Kit (Qty = 5) 2.5" Wide x 3" Deep	XMR03
Quick Mount Base (Qty=10) with Fastener, for 1/4" Holes	XCTM
Cabinet Accessories	
Casters Kit (4), Regular Capacity 1,080 lbs	XCK01
Casters Kit (4), High Capacity 2,250 lbs	XCK02
Levelers Kit (4)	XLK01
Bolt-Together Kit for X Series Cabinet	XBK01

Faster.
Easier.
Better.



XSS Series — Server Cabinet, XSN Series — Networking Switch Cabinet

Certified to Seismic Zone 4 for mission-critical Data Centers

Applications

Belden's seismic cabinets feature a robust steel frame for hosting servers, switches and network components in earthquake zones. Certified to Seismic Zone 4 requirements, these cabinets have passed vibration and shock testing per GR-063-CORE Network Equipment Building System (NEBS) Requirements with no structural damage in a certified lab.

Design and Structural Features

- Welded steel frame construction reinforced with a heavy gauge steel sub-frame for extra rigidity
- Highly perforated doors with stiffener channels ensure sturdiness while reducing risk of equipment damage during seismic events
- Adjustable EIA mounting rails support a 2,000 lb static load under normal operating conditions
- Finger-style vertical managers with brushed cable pass throughs enable front-to-rear routing while maintaining supply-return air sealing properties
- Compatible with passive and active chimney-based containment solutions
- Pre-configured switch cabinets with cable management, air baffles, intake and exhaust duct (for side-to-side venting) and power distribution units (PDUs) to host CISCO Catalyst 6000 and Nexus 7000 Series switches
- Offered in standard colors of black and Central Office white
- Integral anchoring floor mount locations*

*Belden recommends the use of a qualified contractor for the installation of seismic cabinets as per the local, state and federal building code requirements.



XSS and XSN Series Specifications

- Perforated door mesh opening: 78%
- Frame construction: 16-, 12- and 11-gauge welded steel
- Mounting rail construction: 12-gauge, marked RU, RU 1 is at bottom of cabinet
- Static load capacity: 2,000 lbs
- Static load capacity (seismic): 1,000 lbs
- Capacity on casters: 1,080 lbs (regular capacity), 2,000 lbs (high-capacity)
- Seismic certification: Zone 4 NEBS GR-063-CORE
- EIA 310 compliant: 19" mount equipment
- Horizontal Cable Management Options (See page 65 for Accessories)
- Heat Containment Options (See pages 31-34)

XSS and XSN Series Seismic Server Specifications

XSS and XSN Seismic Series Type	X1SS44	X2SS44	X1SN44	X2SN44
Dimensions: W x D x H (of frame)	24" x 48" x 83.75"	30" x 48" x 83.75"	30" x 48" x 83.75"	40" x 48" x 83.75"
Available Mounting Rack Units (RU)	44		44	
Front Frame Opening (W x H)	20.00" x 77.50"	25.50" x 77.50"	25.50" x 77.25"	35.50" x 77.25"
Depth with Doors	50"		50"	
Usable Depth (1)	46"		46"	
Single Door Perforated Area	1,200 sq. in.	1,548 sq. in.	1,548 sq. in.	2,129 sq. in.

Notes:

(1) Distance from front-most mounting rail face to inside of rear frame.

Engineered and made in the USA.



Seismic Configured Cabinets

Configured Cabinets

Belden offers fully configured cabinets as a single part number to meet specific application needs.

The following are a sample of common configurations for Belden XSS and XSN Series.

Contact your local Belden sales representative to discuss your specific needs.



Part No. shown: X2SN-C70182001
(44RU H x 40" W x 48" D)

XSS and XSN Series – Configured Cabinets

Item	Part #	Frame Size			Color*	Rails	Top Panel	Doors		Lacing/PDU Panel	Vertical Manager	
		Width	Depth	Height				Front	Rear		Fingers on Rail	Box Style Mgr.
1	X1SS-C1001	24	48	44RU	Black	Square Rails	Brush Front/Rear	Perf.	Perf.	2 x 7" Rear	Rear Rails	No
2	X1SS-C1002	24	48	44RU	Black	Square Rails	Brush+Chimney Ready	Perf.	Solid	2 x 7" Rear	Rear Rails	No
3	X2SS-C1001	30	48	44RU	Black	Square Rails	Brush Front/Rear	Perf.	Split Perf.	2 x 7" Rear	Rear Rails	No
4	X2SS-C1002	30	48	44RU	Black	Square Rails	Brush+Chimney Ready	Perf.	Split Solid	2 x 7" Rear	Rear Rails	No

Item	Part #	Frame Size			Color*	Rails	Top Panel	Doors		Lacing/PDU Panel	Lacing/PDU Panel with (6) Rings	Horizontal Managers	Air Director Duct Kit	Vertical Manager (Fingers on Rail)
		Width	Depth	Height				Front	Rear					
1	X1SN-C1001	30	48	44RU	Black	Square Rails	Brush Front/Rear	Perf.	Split Perf.	(2) 10" Center	(2) Rear	(4) per Side	None	Front & Rear Rails
2	X1SN-C1002	30	48	44RU	Black	Square Rails	Brush+Chimney Ready	Perf.	Split Solid	(2) 10" Center	(2) Rear	(4) per Side	None	Front & Rear Rails
3	X1SN-C70101001	30	48	44RU	Black	Square Rails	Brush Front/Rear	Perf.	Split Perf.	(2) 10" Center	(2) Rear	(4) per Side	None	Front Rails
4	X1SN-C70101002	30	48	44RU	Black	Square Rails	Brush+Chimney Ready	Perf.	Split Solid	(2) 10" Center	(2) Rear	(4) per Side	None	Front Rails
5	X2SN-C65091001	40	48	44RU	Black	Square Rails	Brush Front/Rear	Perf.	Split Perf.	(2) 10" Center	(2) Rear	(4) per Side	(1) 6509	Front Rails
6	X2SN-C65091002	40	48	44RU	Black	Square Rails	Brush+Chimney Ready	Perf.	Split Solid	(2) 10" Center	(2) Rear	(4) per Side	(1) 6509	Front Rails
7	X2SN-C65091004	40	48	44RU	Black	Square Rails	Brush Front/Rear	Perf.	Split Perf.	(2) 10" Center	(2) Rear	(4) per Side	(2) 6509	Front Rails
8	X2SN-C65091005	40	48	44RU	Black	Square Rails	Brush+Chimney Ready	Perf.	Split Solid	(2) 10" Center	(2) Rear	(4) per Side	(2) 6509	Front Rails
9	X2SN-C70181001	40	48	44RU	Black	Square Rails	Brush Front/Rear	Perf.	Split Perf.	(2) 10" Center	(2) Rear	(4) per Side	7018	Front Rails
10	X2SN-C70181002	40	48	44RU	Black	Square Rails	Brush+Chimney Ready	Perf.	Split Solid	(2) 10" Center	(2) Rear	(4) per Side	7018	Front Rails

* For Central Office White color, replace 1 with 2 (ex: X1SS-C2001, X1SN-C70102001).

Notes:

All configured cabinets include one Side Panel and one Bottom Panel with Brush.

Switch-specific configuration includes all cabinet components needed to host given switch.

Power Distribution Units (PDUs) are not included in above configurations, refer to PDUs Section of the catalog (pgs. 69–76) for options.

Configured seismic cabinets include front rail air seal kit.

For "chimney-ready" configuration, refer to Containment Section of the catalog (pgs. 31–34) for chimney and accessories options.

Faster.
Easier.
Better.

Ordering Matrix for Seismic Server Cabinets (XSS)

Part number example:

X2SS441211222

XSS Cabinet, 30"Wx48"D frame, 44RU, Black, 10-32 tapped rear rails, solid top panel, perforated front door, split perforated rear door, 2 side panels, bottom panel with brush opening.

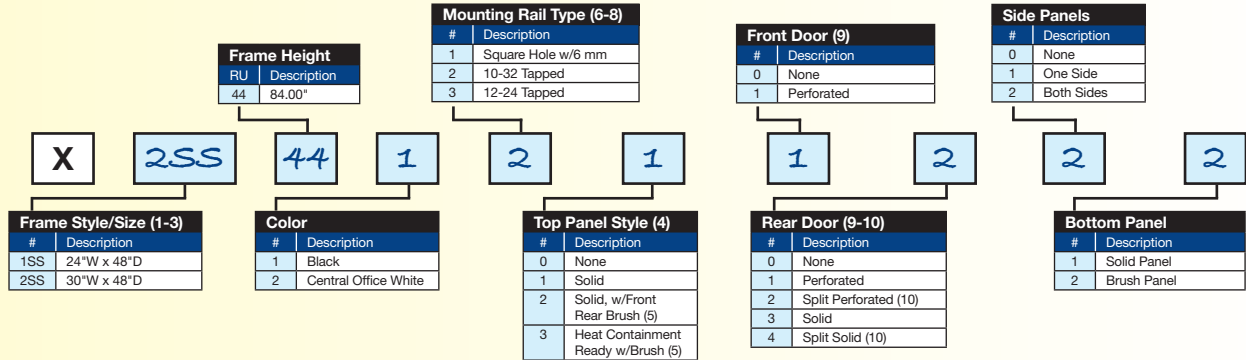

Notes:

- Cabinet dimension (measured without doors).
- Cabinet construction: Welded steel, ganging hardware, grounding studs in frame base front and rear.
- Cabinet static load capacity is 2,000 lbs, Cabinet seismic load capacity is 1,000 lbs; BELLCORE GR-63-CORE, Section 5.4.1 Certification.
- Custom top panel available on request for volume orders.
- 30" wide frame is provided with six top brush openings for networking and power cable entry.
- 11 AWG mounting rails provide standard 19" rack spacing to EIA-310-D requirements.
- Equipment mounting hardware (50) included with rails (4).
- Each EIA Rail has numerical marking for each rack unit (starting at unit 1 at bottom).
- Doors are surface mounted, reversible and provisioned with "swing handle" hardware, allowing changing of locksets.
- Split doors only available on 30" wide frame, with three-point latching "swing handle" hardware to facilitate change of lock set.

XSS Series – Options and Accessories

EIA Mounting Rails

Includes two pair of rails and mounting hardware (50). Default hardware for square hole style rails is M6.

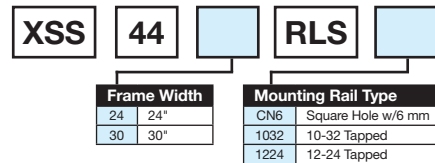

Side or Separator Panel

Includes one side panel. Seismic panel provisioned to be bolted to cabinet.

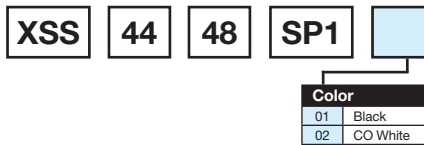

Description	Belden Part Number
Front Rail Air Seal Kit (with side air blockers)	
Front Rail Air Seal Kit, 44RU, 24" Wide, Black	XSS4424RSK01
Front Rail Air Seal Kit, with Brush Openings, 44RU, 30" Wide, Black	XSS4430RSK01
Front Rail Air Seal Kit, 44RU, 24" Wide, CO White	XSS4424RSK02
Front Rail Air Seal Kit, with Brush Openings, 44RU, 30" Wide, CO White	XSS4430RSK02
Cable Manager Lacing Panels	
Vertical Manager Panel 3.5" Wide, Black	XSSVMP014401
Vertical Manager Panel 7.0" Wide, Black	XSSVMP024401
Vertical Manager Panel 3.5" Wide, CO White	XSSVMP014402
Vertical Manager Panel 7.0" Wide, CO White	XSSVMP024402
Cable Manager Fingers for Mounting Rails	
Finger Strip Kit for 1 Rail, 44RU (mounts to EIA rail)	XSSFS4401
Finger Strip (Qty=1) 11RU Section	XMFS01

Ordering Matrix for Seismic Networking-Switch Cabinets (XSN)

Part number example:

X1SN441311222

XSN Cabinet, 40"Wx48"D frame, 44RU, black, 12-24 tapped rails, solid top panel, perforated front door, split perforated rear door, 2 side panels, bottom panel with brush opening.

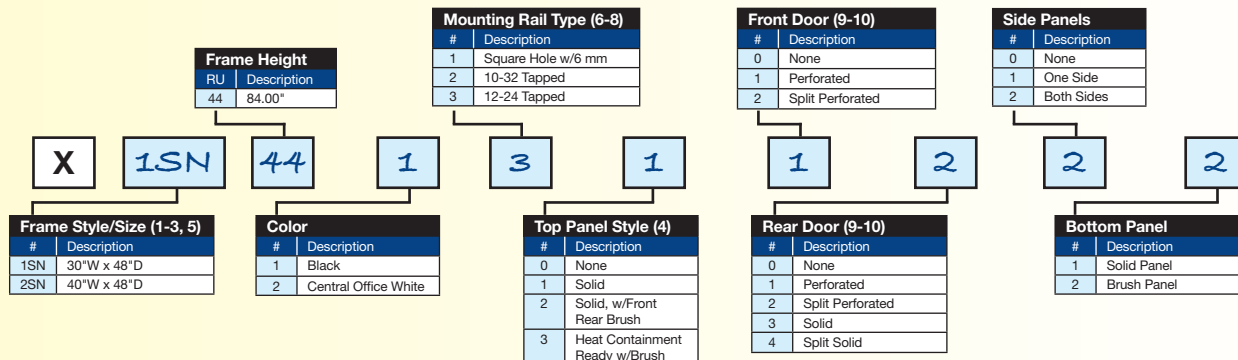

Notes:

- Cabinet dimension (measured without doors).
- Cabinet construction: Welded steel, ganging hardware, grounding studs in frame base front and rear.
- Cabinet static load capacity is 2,000 lbs, cabinet seismic load capacity is 1,000 lbs; BELLCORE GR-63-CORE, Section 5.4.1 Certification.
- Custom top panel available on request for volume orders.
- Cabinet frame is provided with six top brush openings for networking and power cable entry.
- 11 AWG mounting rails provide standard 19" rack spacing to EIA-310-D requirements.
- Equipment mounting hardware (50) included with rails (4).
- Each EIA Rail has numerical marking for each rack unit (starting at unit 1 at bottom).
- Doors are surface mounted, reversible and provisioned with "swing handle" hardware, allowing changing of locksets.
- Split doors only available on 30" wide frame, with three-point latching "swing handle" hardware to facilitate change of lock set.

XSN Series – Options and Accessories

EIA Mounting Rails

Includes two pair of rails and mounting hardware (50). Default hardware for square hole style rails is M6.

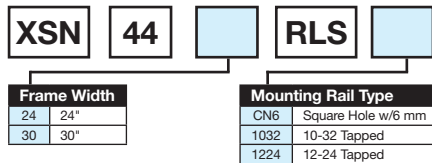

Side or Separator Panel

Includes one side panel. Seismic panel provisioned to be bolted to cabinet.

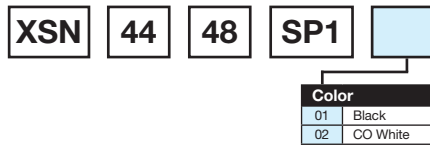

Description	Belden Part Number
Cable Lacing Panels	
Vertical Manager/Lacing Panel, 10" Wide, Black	XSNVMP440301
Vertical Manager/Lacing Panel, 10" Wide, CO White	XSNVMP440302
Cable PDU/Manager Rear Panel	
Cable PDU Manager Rear Panel, 44RU, Rear, Black	XSN44VRPM101
Cable PDU Manager Rear Panel, 44RU, Rear, with 6 Rings, Black	XSN44VRPM201
Cable PDU Manager Rear Panel, 44RU, Rear, CO White	XSN44VRPM102
Cable PDU Manager Rear Panel, 44RU, Rear, with 6 Rings, CO White	XSN44VRPM202
Top Cable Trough with Cover	
Top Cable Trough with Cover, 30" Wide, Black	XSNTCT3001
Top Cable Trough with Cover, 40" Wide, Black	XSNTCT4001
Top Cable Trough with Cover, 30" Wide, CO White	XSNTCT3002
Top Cable Trough with Cover, 40" Wide, CO White	XSNTCT4002

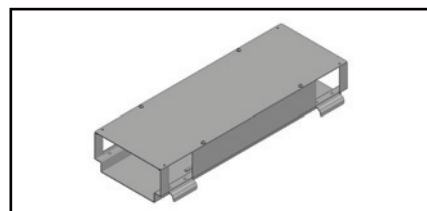

Top Cable Through with Cover (8.5" W x 4.0" H)

Faster.
Easier.
Better.



Heat Containment Systems

Aisle and Cabinet Containment Systems

Containment Overview

A major challenge faced by data center managers today is ensuring that cooling systems do not fail and continue to provide uninterrupted cool air to equipment, especially in high-density data center environments with advanced virtualized equipment that can reach exhaust air temperatures in excess of 125° F. Most data centers that use a standard cold/hot aisle approach are oversupplied with cold air at a ratio of 2 to 2.5 (volume of cold air supplied to volume consumed by computing equipment). With cooling representing 30-40% of total operational costs for a typical data center, containment solutions present a strong ROI potential. A standard cold/hot aisle approach can also lead to hot spots that cause equipment overheating and failures, further resulting in higher operating costs.

Containment is an industry proven method of eliminating cold air bypass and the mixing of hot and cold air that allows for optimal use of available cooling capacity for overall lower operating costs. With containment, hot exhaust air from equipment is directed to CRAC units either through aisle containment systems for groups of cabinets or through active or passive chimneys at the cabinet level. This increases the differential between the inlet and outlet temperatures of CRAC units, significantly improving overall cooling system efficiency and eliminating the need to oversupply cold air. Creating separation between the hot return air and cold supply air also allows for potentially raising the supply air temperature while maintaining stable intake temperature for networking equipment, providing a more efficient, reliable and hot spot-free computing space. The containment approach easily handles the high-temperature exhaust air from advanced data processing equipment, allowing data centers to host more equipment while lowering energy consumption and total operating costs.

Belden's complete line of containment options range from the cabinet to the cold/hot aisle, offering customers the greatest flexibility for upgrading, designing and implementing a tailored solution that fits their specific data center needs in both "brownfield" or "greenfield" applications. Based on computing load, cabinet layout and computing space specifications, Belden engineers can recommend and design containment solutions that will optimize availability, efficiency and hosting capacity.



- Eliminates bypass air and air recirculation
 - Reduces or eliminates cold air oversupply (2.5 to <1.2)
 - Maximizes hosting density for up to 30kW per cabinet without precision cooling
 - Increases supply air temperature (better use of economizer loop, 8–10°)
 - Increases return air temperature for better CRAC efficiency
- Reduces cooling cost by 30–50% over traditional hot/cold aisle deployment
- Creates a high level of separation between supply and return air
- Eliminates hot spots for increased IT equipment availability



Heat Containment Systems (continued) Hot and Cold Aisle Containment Systems

Aisle Containment

Belden's Aisle Containment solutions eliminate mixing of hot and cold air in data center environments to maximize energy efficiency and lower operating costs. Our aisle containment systems are vendor agnostic, featuring innovative transparent panels that are lightweight and easily attached horizontally or vertically to data center cabinets using a universal rail system. The panels are field modifiable to meet varying height and space requirements between rows of cabinets and from the top of the cabinets to the ceiling. The aisle containment systems can also interact with smoke or fire alarm systems to ensure proper operation of critical fire suppression and safety systems.

Solutions offered are for both hot and cold aisle containment system.

Vertical Containment

Vertical panels direct hot return air to overhead return plenum, eliminating mixing and improving overall operating efficiency of perimeter CRAC units. Using a fully ducted cold air delivery system with vertical panels also allows for cold air to be placed directly into the cold aisle, eliminating the need to use the underfloor space for supply air.

Horizontal Containment

For raised-floor environments with overhead obstructions or no ceiling plenum, non-ducted panels form a roof to trap cold air, enabling higher supply temperatures and maximizing available cooling. This design can also be used for data centers utilizing in-row cooling solutions.

Aisle Doors

Belden offers both swinging and sliding door options for the end of the row.



Faster.
Easier.
Better.



Heat Containment Systems (continued)

Hot and Cold Aisle Containment Systems

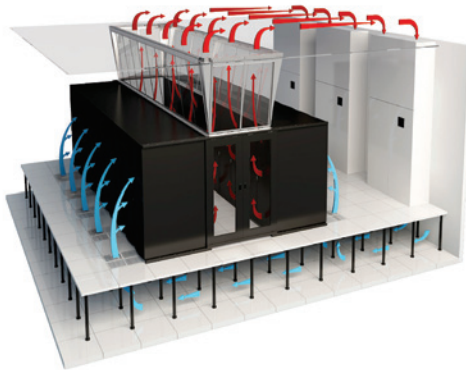

Hot-Aisle Vertical Style Design

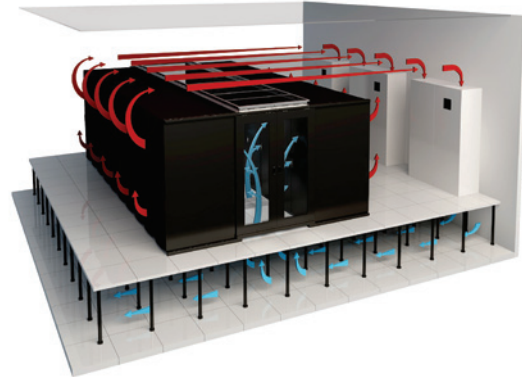

Cold Aisle Horizontal Design

Vertical Style Heat Containment

Part number example from configuration shown below:

XSAC1143.720032

Fixed Letter Series	1. Choose Cabinet Series	Fixed Letters	2. Choose pod type	3. Choose containment panel type	4. Measure distance cabinet to ceiling	5. Enter aisle length	7. Choose aisle width	8. Choose door type
X	S	AC	1	1	43.7	200	3	2
Cabinet Series End⁹	Hot Air/Cold Air²	Panel Orientation³	Vertical Panel⁴	Aisle Length in inches⁵	Aisle Width⁶	Door Options⁷		
# Description	# Description	# Description	# Description	# Description	# Description	# Description	# Description	# Description
M XHM-Series	1 Hot Aisle	1 24" Vertical Fixed Black	## Ceiling Height	1 48	1 Swing Door Black			
N XN-Series	2 Cold Aisle	2 24" Vertical Fixed White	### Cabinet Height	2 54	2 Swing Door White			
S XHS-Series		3 24" Vertical Hinged Black		3 60	3 Sliding Door Black			
Z Custom		4 24" Vertical Hinged White		4 66	4 Sliding Door White			
				5 72				

Notes

- Enter the end of row cabinet for mounting door, (will have to know top and side attachment points of customer cabinet)
- Enter cabinet pod type, cold air or hot air containment
- Enter containment panel type
- Enter aisle width or custom width in inches
- Enter aisle length in inches, there will be a trim piece for panels under 24"
- Enter aisle width or custom width in inches, custom widths available on request
- Enter door type, sliding or swing, must enter cabinet end of row type for mounting of doors
- Custom colors available on request
- There may have to be modifications to customer cabinets at location

Horizontal Flat Heat Containment Tops

Part number example from configuration shown above:

XSAC11052004333

Fixed Letter Series	1. Choose Cabinet Series	Fixed Letters	2. Choose pod type	3. Measure distance cabinet to ceiling	4. Enter aisle length	5. Choose exhaust option 1	6. Choose quantity option 1	7. Choose aisle width	8. Choose door type
X	S	AC	1	105	200	4	3	3	3
Cabinet Series End¹¹	Hot Air/Cold Air²	Height Cabinet to Ceiling³	Aisle Length in inches⁴	Exhausting per row^{5,12}	Quantity of Option 1	Aisle Width⁷	Door Options⁷		
# Description	# Description	# Description	# Description	# Description	# Description	# Description	# Description	# Description	# Description
M XHM-Series	1 Hot Aisle	### Ceiling Height		0 None	0 5	1 48	1 Swing Door Black		
N XN-Series	2 Cold Aisle	### Cabinet Height		1 10" fan	1 6	2 54	2 Swing Door White		
S XHS-Series				2 Chimney Adapter	2 7	3 60	3 Sliding Door Black		
Z Custom				3 AEHC Heat Containment	3 8	4 66	4 Sliding Door White		
					4 9	5 72			

Notes

- Enter the end of row cabinet for mounting door, (will have to know top and side attachment points of customer cabinet)
- Enter cabinet pod type, cold air or hot air containment
- Enter ceiling height and (cabinet height (3 options)
- Enter aisle length or custom width in inches
- Enter fan or chimney adapter, or AEHC Heat Containment (Chimney sold separately)
- Enter only 1 number 0 - 9 (there are 2 columns)
- Enter aisle width
- Enter door type, sliding or swing, must enter cabinet end of row type for mounting of doors
- Custom colors available on request
- Pods will all come with solid horizontal panels unless using (option 1)
- There may have to be modifications to customer cabinets at location



Heat Containment Systems (continued)

Passive and Adaptive Cabinet Heat Containment (AEHC) System

AEHC chimney shown here in through-the-ceiling version

Passive chimney shown here in adjustable and against-the-ceiling version



AEHC chassis (23.5"Wx16.9"Dx11.5"H) host the fans and controller

Example of both Passive and Active Chimney Systems

Containment Cabinets

- Designed for chimney containment, Belden XHM, XS, XSS-XSN Seismic and XN Series cabinets feature sealing front mounting rails that separate cold supply air from hot return
- 42" or 48" deep cabinets are recommended for optimal chimney containment performance
- Gasketed solid rear door options and brushed cable entries prevent hot return air from leaking back into computing space
- All X Series cabinets can be equipped with passive or active chimneys

Passive and Active Chimney Systems

- Active system can support up to 30kW per cabinet for today's extremely high heat loads
- Passive systems rely on the effectiveness of server fans, combined with pressure differential between the cabinet and return spaces
- Passive system capacity peaks around 10kW (but can be higher) and varies based on chimney length, position in relation to CRAC, return plenum pressure and exhaust air temperature
- Passive and active chimneys are available as through-ceiling chimneys that protrude approximately 2" into the return plenum, and against-the-ceiling chimneys that adjust and feature a rubber gasket for effective sealing against the drop ceiling
- To account for fans and controller units, chimney length for active containment should be sized by deducting 11.5" from distance between cabinet top and return ceiling
- Belden X Series cabinets equipped with containment top panels accept both passive and active chimneys, allowing for easy passive-to-active conversion

AEHC Overview

Belden's active Adaptive Cabinet Heat Containment (AEHC) System is a highly efficient and cost-effective method for cooling cabinets while preventing the mixing of hot and cold air in the data center. When networked, AEHC chimneys allow aggregation of exhaust air volume of entire cabinet pods, enabling real-time control of CRAC units and creating a logical link between the cooling plant and the computing load. This unique attribute allows reduction of cooling-operating costs, particularly in virtualized, clustered computing environments characterized by highly dynamic computing loads.

- AEHC uses high-capacity fans controlled by a pressure sensor to ensure dynamic balancing of intake and exhaust air volumes
- Maintains neutral pressure in the cabinet plenum for highly efficient server fan operation
- Can be networked in a pod/row for redundancy in virtualized, clustered computing environments
- Multiple cabinets can share AEHC chimneys based on hosted computing density (three cabinets per chimney is typical)
- AEHC is highly scalable with chimneys added as needed with increased computing loads
- A pair of hot swappable brushless fans with a combined capacity of 10 or 30kW connect to the AEHC controller, enabling quick and easy capacity upgrades (different capacity fans cannot be used in the same cabinet)
- Fan motors are engineered to ensure longevity, high air displacement and low power consumption for mission-critical facilities
- Ideal for existing data centers, and non-Belden cabinets can be retrofitted with chimney by using a customized adapter plate

Faster.
Easier.
Better.



Heat Containment Systems (continued)

Pressure-based containment control for best use of cooling capacity

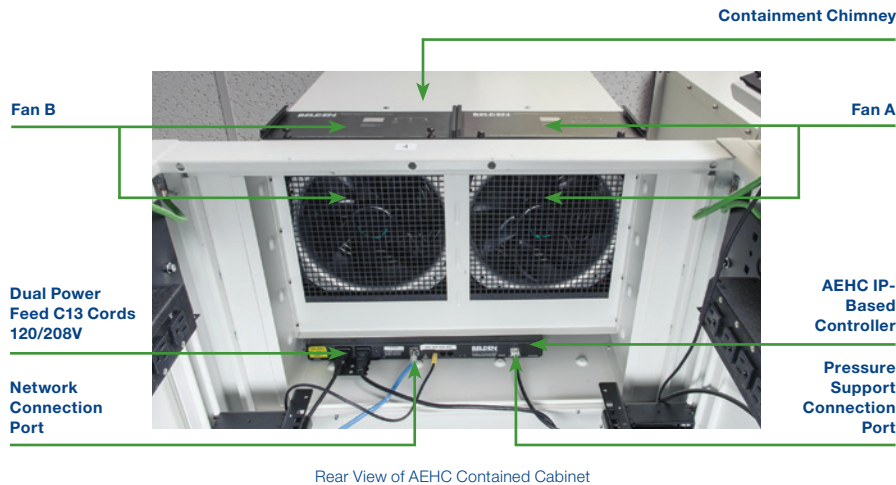

- The AEHC system is powered (autosensing 120 or 208V) via the cabinet PDUs and accepts two distinct power feeds for redundancy
- A combination of temperature-humidity sensors with AEHC controller can collect and store environmental data. When networked, real-time data can be accessed via the intuitive user interface or Belden Cormant-CS Infrastructure Management Software using SNMP (MIB file)
- Environmental, mechanical and electrical thresholds and alarms are easy to configure and can be sent directly to e-mail addresses (through an escalation process)

Belden AEHC Is Comprised of:

- An cabinet configured to accept the AEHC system
- A chassis with controller and two fans
- A controller for power input and system networking and control
- A pair of AEHC fans per chassis with a combined containment capacity of 10 or 30kW
- A pressure sensor for fan speed control
- A dual-function temperature/humidity sensor to monitor intake air
- An AEHC chimney to provide the physical link between the chassis and return plenum

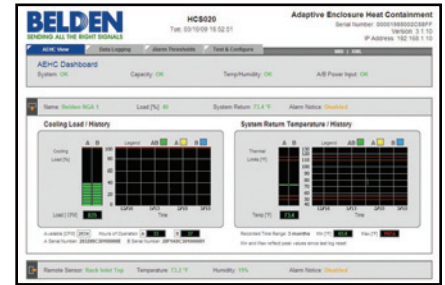

Embedded software allows each AEHC unit to be fully autonomous. The AEHC controllers have their own IP address, enabling network connection. The AEHC then allows for real-time monitoring of the heat load, temperature and alarm conditions for each IT cabinet.



The threshold setting in Belden's AEHC system provides early warning alarms for problem conditions. Alarms are automatically reported. Supported Network Protocols: DHCP, HTTPS, SMTP/POP3, HTTP, ICMP, TCP/IP, SNMP, DNS.

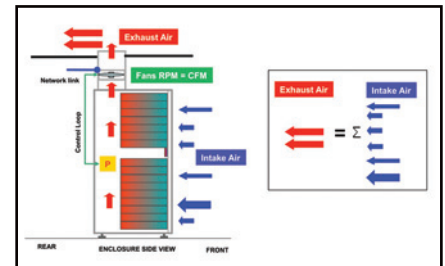
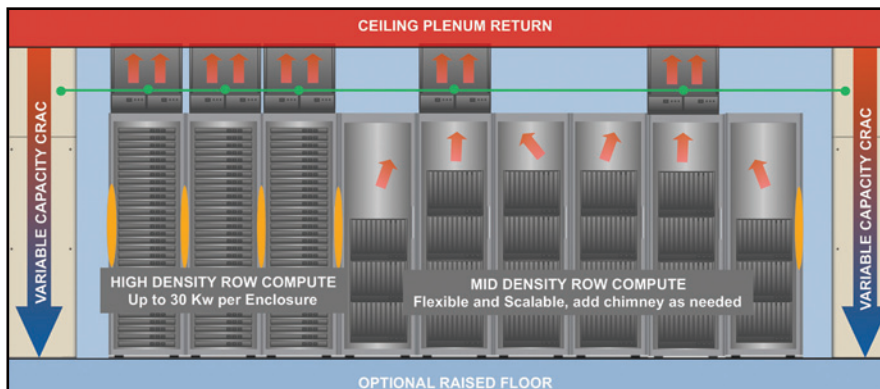

AEHC Single Cabinet Diagram (Side View)



AEHC Controller



Intelligent hot swappable fan cartridges allow for ease of maintenance and system scalability.

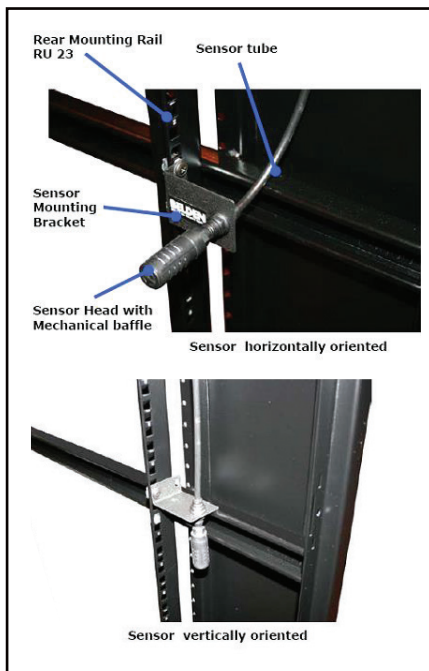

Belden's AEHC System utilizes pressure sensing to dynamically adjust for speed, resulting in perfect balance between intake and exhaust air volume.

Heat Containment Systems (continued)

Options and Accessories

Passive Chimney — Through Ceiling

HCDP0

Chimney Height			
24	24"	60	60"
33	33"	66	66"
36	36"	72	72"
42	42"	78	78"
48	48"	84	84"
54	54"		

Color	
B	Black
W	CO White

Passive Chimney — Against Ceiling (Adjustable)

HCDPA0

Chimney Height			
24	21"-27"		
36	33"-39"		
48	45"-51"		
60	57"-63"		
72	69"-75"		
84	81"-87"		

Color	
B	Black
W	CO White

AEHC Chimney — Through Ceiling

HCD0

Chimney Height			
24	24"	60	60"
33	33"	66	66"
36	36"	72	72"
42	42"	78	78"
48	48"	84	84"
54	54"		

Color	
B	Black
W	CO White

AEHC Chimney — Against Ceiling (Adjustable)

HCD A0

Chimney Height			
24	21"-27"		
36	33"-39"		
48	45"-51"		
60	57"-63"		
72	69"-75"		
84	81"-87"		

Color	
B	Black
W	CO White

Adaptive Cabinet Heat Containment System

Includes (1) Black Chassis, (1) Controller, (2) Fan Cartridges, (1) Pressure Sensor, (1) Temperature/Humidity Sensor, (2) C13 Power Cords, (2) 5-15P Power Cords

HCS0

Containment Capacity	
10	10kW
30	30kW

Color	
B	Black
W	CO White

Description	Belden Part Number
-------------	--------------------

Other Accessories

AEHC Controller	
AEHC Controller (1) with Power Cords C13 (2), 5-15P (2)	HCH001
AEHC Fans	
AEHC 10kW AEHC Fan (1) with Digital Display	HCFD10
AEHC 30kW AEHC Fan (1) with Digital Display	HCFD30
AEHC Sensors	
AEHC Dual Function Temperature/Humidity Sensor (1)	HCP002
AEHC Pressure Sensor (1)	HCP001
AEHC Chassis	
AEHC Chassis, Black	HCC001-B
AEHC Chassis, Central Office White	HCC001-W
AEHC Chassis Blank Panels	
AEHC Chassis Blank Panels, includes Blank for Fans and Controller, Black	HCCBP-B
AEHC Chassis Blank Panels, includes Blank for Fans and Controller, Central Office White	HCCBP-W
Chimney Blank Panel for Active or Passive Containment (compatible with 24", 30" and 40" cabinets)	
Black	HCDBP-B
Central Office White	HCDBP-W

Faster.
Easier.
Better.

XNM Series – NEMA-12 Cabinets

Ideal for use in industrial networking



XNM Style NEMA-12 Cabinet with Front and Rear Doors, Side Panels, EIA Mounting Rails and Optional Side-Mounted Air Conditioning Unit. Part No. shown: XNM84-3-11212.

Applications

Designed for dusty environments, Belden XNM cabinets allow hosting of networking/control equipment in factories, warehouses and on the production floor. Optional air conditioning AC units allow temperature control for stand-alone applications. Belden has extensive NEMA-style networking cabinet experience and capability to customize products-solutions.

Design and Structural Features

- NEMA 12 compliant for hosting servers and switches in industrial environments
- Free standing welded frame with modular construction
- 84"H x 29"W x 40"D
- Mounting rails are adjustable to either 19" or 23" EIA spacing
- Three-point compression-style lift-and-turn latch system
- Glass front door uses scratch-resistant tempered safety glass

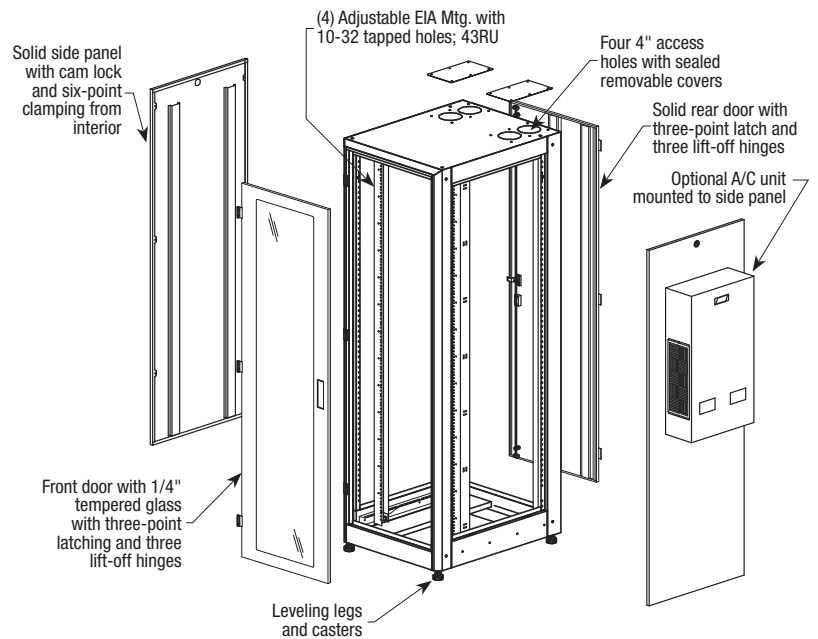

XNM Front with Doors and Panels

Ordering Matrix for NEMA-12 Cabinets

Part number example:

XNM84311212

XNM Cabinet, 29"Wx40"D frame, 45RU, black, 19" mount 10-32 tapped rails, 2500 BTU AC, glass front door, solid rear door, 2 side panels.

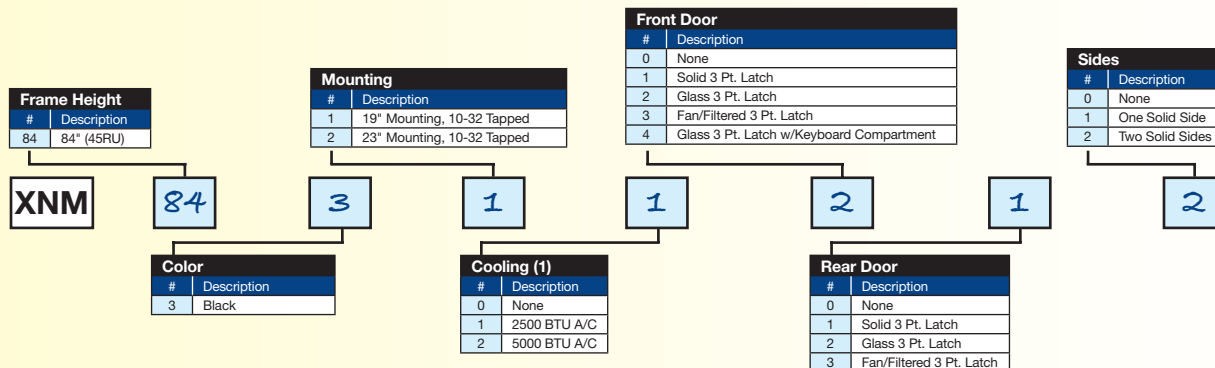

Notes:

1) *Additional cooling options up to 20K BTU/AC available.

Technical Specifications

Belden Part Number	H	W	D	Mounting	Cabinet Weight*	Load Capacity**	Rack Spaces	Usable Depth	
Cabinet Size (Including gland plate, casters and levelers)								At Latch	To Inside of Door
XNM84-3-10000	84"	29"	40"	19" or 23"	462 lbs	2,000 lbs	45RU	37.5"	38.5"

* Cabinet weight is an estimate for shipping a fully configured cabinet with Top, Doors, Sides and Power Strip.

** Load capacity on levelers.

Cabinet Components: Doors and Side Panels

Description	Belden Part Number
Front/Rear Doors	
Solid w/3 pt. Swing Handle Latch and Lock	8429-NSD-3
Tempered Glass w/3 pt. Swing Handle Latch and Lock	8429-NGD-3
Fan/Filtered (7" fan = 235 CFM) with 3 pt. Swing Handle Latch and Lock	8429-NFD-3
Tempered Glass w/Keyboard Compartment with Fan/Filtered Latch	8429-NKD-3
Side Panels	
One Solid w/Lock	8440-01-NSP-3
Two Solid w/Lock	8440-02-NSP-3



Air Conditioning Units

Air Conditioners

Most Belden cabinets can be customized to accept highly efficient air conditioning units.

Technical Specifications

BTUs/Hr.	Volts (Hz)	Amps (max.)	Temp. (max.)	Weight	H	W	D
Air Conditioning Units							
2200	120/60	6.0	125° F	57 lbs	30.1"	12.27"	6.34"
3000	120/60	8.1	125° F	57 lbs	30.1"	12.27"	6.34"
3800	120/60	7.8	125° F	65.5 lbs	30.1"	12.27"	8.34"
2500	120/60	7.9	125° F	73 lbs	28.5"	19.25"	6.38"
3500	120/60	8.2	125° F	73 lbs	28.5"	19.25"	6.38"
5000	120/60	8.7	125° F	74 lbs	28.5"	19.25"	6.38"
12000	120/60	19.6	131° F	139 lbs	52.1"	17.65"	10.34"

Faster.
Easier.
Better.

CH Series Cabinets

Multi-use cabinet balancing performance and value



Highly versatile, cost-efficient 19" mount cabinet provides quality solutions for a wide variety of IT, Security and Data Center applications. Perfect for both stand-alone or ganged configurations.

Features

- Available in:
 - 24" and 30" width options
 - 42" and 48" depth options
 - 42RU Height
- 3000 lbs static load
- Fully welded 14 awg frame, cold rolled steel construction
- Manufactured with premium-grade hot and cold rolled steel sheet
- Contoured high-density perforated quick-release, field-reversible doors
- Two-piece side panels provide convenient access to installed equipment in stand-alone applications
- Standard 19" mount per EIA -310D per EIA-310E, cage nut style rail
- Fully adjustable mounting rail depth
- Rack unit (RU) identifier printed on mounting rails for quick identification
- Open bottom for easy cable access
- Top panel with rear brush opening
- All materials RoHS compliant

Standard Configuration includes

- Black powder-coat paint
 - Perforated front door with lock handle
 - Split perforated rear door with lock handle
 - Four EIA mounting rails, cage nut style with M6 hardware included (50 pieces)
 - Cable routing opening in mounting rails (only for 30" wide cabinet)
 - Two solid side panels
 - Top panel with brushed openings
 - Open bottom
 - Two rear cable lacing/PDU mount panels
 - Casters, levelers and ganging kit/hardware included
 - Grounding provision front/rear and top/bottom
 - Bonding wires between frame and doors
 - For shelves and horizontal managers
- see pages 66-67
- For PDUs see pages 71-80

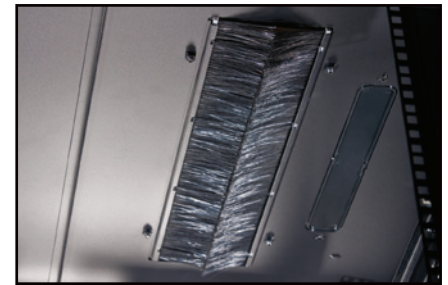
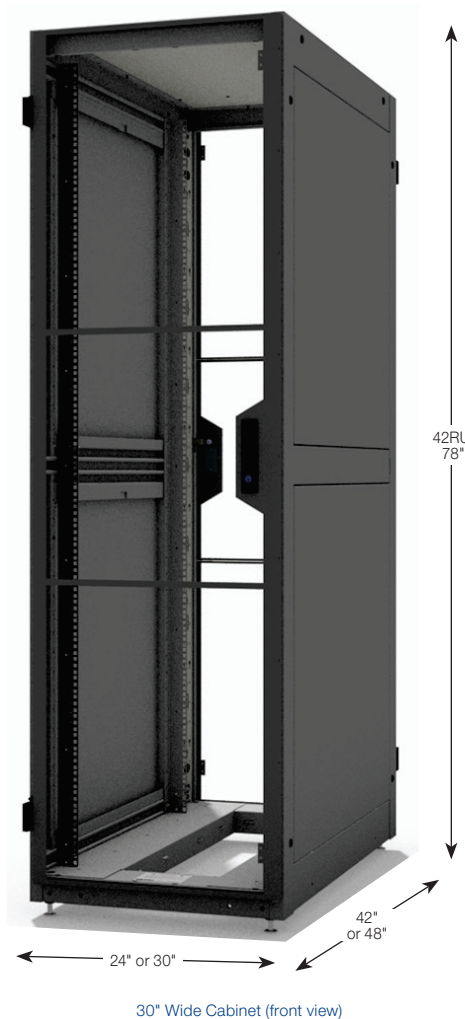

Brushed Top Panel Opening

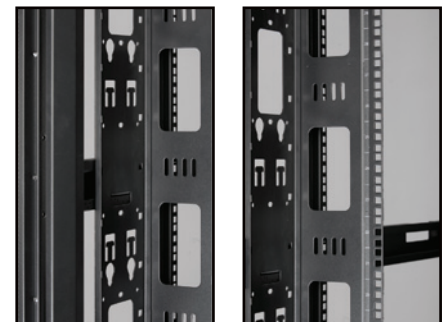

(2) Rear Cable Lacing/PDU Mount Panels

Cable Routing Opening in Mounting Rails for the 30" Wide Cabinet



CH Series Cabinets (continued)

Available in 24" and 30" width options

Ordering Information

Description	Belden Part Number				Belden Part Number			
	CH1S42-211221		CH2S42-211221		CH1S42-211221		CH2S42-211221	
Width	24 in	610 mm	24 in	610 mm	30 in	762 mm	30 in	762 mm
Depth Without Doors	42 in	1067 mm	48 in	1219 mm	42 in	1067 mm	48 in	1219 mm
Height	42RU		42RU		42RU		42RU	
Height without Casters	78.75 in	2000 mm	78.75 in	2000 mm	78.75 in	2000 mm	78.75 in	2000 mm
Height with Casters	80.13 in	2035 mm	80.13 in	2035 mm	80.13 in	2035 mm	80.13 in	2035 mm
Net Weight with doors and sides	236 lbs	107 kg	250 lbs	113 kg	282 lbs	128 kg	296 lbs	134 kg
Static Load Capacity	3000 lbs	1361 kg	3000 lbs	1361 kg	3000 lbs	1361 kg	3000 lbs	1361 kg
Usable depth, Max. distance between front and rear rails	40.8 in	1035 mm	46.8 in	1187 mm	40.8 in	1035 mm	46.8 in	1187 mm
Perforated doors mesh opening	78%		78%		78%		78%	
Total depth with doors	44.38 in	1127 mm	50.38 in	1280 mm	44.38 in	1127 mm	50.38 in	1280 mm
Door Opening Radius - stand alone enclosure	270°		270°		270°		270°	



XWM-2109-GD



XWM-2312-SD

XWM Series – Wall Mount Cabinets

Wall Mount Cabinets are an ideal hosting option in confined spaces



Applications

Wall mount cabinets provide IT/Networking hosting in spaces that often serve another primary function, and where space optimization is critical. They are designed for applications that require secure hosted devices and are ideal for locations where floor mounting space is limited, as is common in retail establishments, schools and offices.

Available in mounting unit increments of 9RU, 12RU and 20RU, Belden Wall Mount Cabinets offer great aesthetics, rugged construction, optimized equipment access and flexible cable management and access features.

Design and Structural Features

- Sturdy welded steel construction
- Durable black powder-coat finish
- Front door options: vented, smoked Plexiglass or solid front
- Door swing direction is field reversible
- Lockable front door, sides and rear section
- Open rear section for cable access through mounting wall
- Top and bottom holes in rear section for conduit connection and cable access
- Comes with mounting template for quick and easy wall mounting
- Removable sides for improved access (12RU and 20RU only)
- Two pairs of 12-24 tapped 19" EIA depth-adjustable mounting rails (includes mounting hardware)
- Swing-out mid-section for rear access to equipment
- Vented front (Plexiglass door only), sides, top and bottom panels for proper heat dissipation
- Top and bottom panel allow optional 4" fan mounting

Faster.
Easier.
Better.



XWM Series – Wall Mount Cabinets (continued)

Dimensions

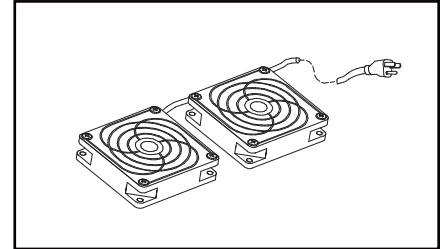
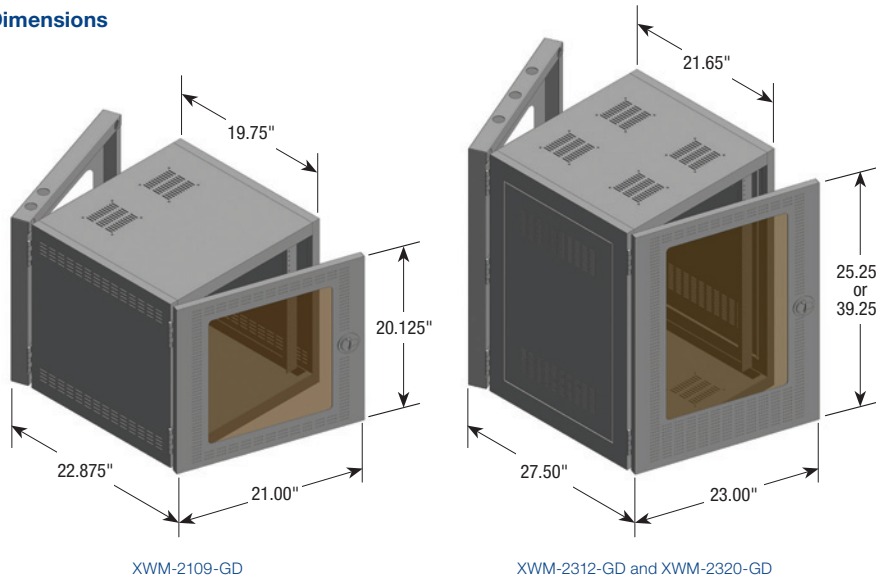

XWM-9312-1600 Fan Assembly

Ordering Information

Belden Part Number	W	H	D	Cable Entry	Mounting	Removable Side Panels	Rack Unit (RU)	Door Type	Weight	Weight Capacity
Wall Mount Cabinets										
XWM-2109-GD	21"	20.12"	22.87"	(4) 1" Conduit	(4) 13/32" dia.	No	9	Plexiglass	45 lbs	130 lbs
XWM-2109-SD	21"	20.12"	22.87"	(4) 1" Conduit	(4) 13/32" dia.	No	9	Solid	45 lbs	130 lbs
XWM-2312-GD	23"	25.25"	27.5"	(6) 2" Conduit	(4) 13/32" dia.	Yes	12	Plexiglass	70 lbs	150 lbs
XWM-2312-SD	23"	25.25"	27.5"	(6) 2" Conduit	(4) 13/32" dia.	Yes	12	Solid	70 lbs	150 lbs
XWM-2320-GD	23"	39.25"	27.5"	(6) 2" Conduit	(6) 13/32" dia.	Yes	20	Plexiglass	95 lbs	175 lbs
XWM-2320-SD	23"	39.25"	27.5"	(6) 2" Conduit	(6) 13/32" dia.	Yes	20	Solid	95 lbs	175 lbs

Description	Belden Part Number
Optional Accessories	
Fan Assembly (2-4" Diameter Fans, 160 CFM with Guard)	XWM-9312-1600
Lacing Panel 3" Wide x 9RU	XWMLP9
Lacing Panel 3" Wide x 12RU	XWMLP12
Lacing Panel 3" Wide x 20RU	XWMLP20
12-24 Mounting Hardware (Bag of 25)	8917-0125
PDU, Rack Mount, 1RU, 120V, 15A, 5-15P Plug w/10' Cord, 6 x 5-15R Receptacles, On/Off Switch, Thermal Circuit Breaker and Surge Suppression	9BF1-061002
PDU, Rack Mount, 1RU, 120V, 20A, 5-20P Plug w/10' Cord, 10 x 5-20R Receptacles, On/Off Switch, Thermal Circuit Breaker and Surge Suppression	9BG1-101001



SecurePatch® Open Rack Security Door



Wall mounted SecurePatch BSP-22U-12SK



11U 6" Deep - BSP-11U-6PK

SecurePatch provides security for new and existing network components in an open 19" equipment rack. The SecurePatch cover provides a security solution to only the section of the rack space you need. Safe guard against unauthorized patch cord movement by retro-fitting loaded equipment racks with the added security of a lockable door.

Benefits

- Adds security without network downtime
- Controls rack access
- Provides second level lock security
- Clamshell design allow back to back mounting of SecurePatch for securing front and rear
- No need to re-terminate
- Mounting flange allows one person to install each unit

Features

- Can be rack or wall mounted on a backboard
- Slotted mounting flange allows for single person install
- Multiple side knock-out options allow for low/high capacity cable feed through
- Connecting bracket enables 11U/22U units to be connected in any combination, while allowing patch cord pass through from one unit to another

Product Specifications

- 16 ga. cold rolled steel
- 19" rack mounting per EIA-310-D
- Finish: black powder coat
- Door options: steel, mesh, or plexiglas door
- Keyed locks standard on door
- Combination locks available
- Ships unassembled
- Easy to follow assembly instructions



BSP-D44U-6PK

Ordering Information

Description	Height	Depth	Belden Part Number
11U" SecurePatch Complete Units (standard black powder coat)			
11U SecurePatch with keyed door	19.25"	6.00"	BSP-11U-6(x)
11U SecurePatch with keyed door	19.25"	12.00"	BSP-11U-12(x)
22U" SecurePatch Complete Units (standard black powder coat)			
22U SecurePatch with keyed door	38.50"	6.00"	BSP-22U-6(x)
22U SecurePatch with keyed door	38.50"	12.00"	BSP-22U-12(x)
44U" SecurePatch Kits Complete Units (standard black powder coat)			
(2) 22U SecurePatch w/ connector brackets, keyed doors	77.00"	6.00"	BSP-44U-6(x)
(4) 22U front and rear kit with keyed doors	77.00"	6.00"	BSP-D44U-6(x)

Replace (x) with door code: PK= Plexiglas, MK=Mesh, SK=Steel

SecurePatch Accessories

Description	Quantity	Belden Part Number
Connecting bracket - for retrofitting 2 SecurePatch together	1	BSP-CBRKT
Quarter-turn with 3 number combination lock	1	BSP-LOCK-C1
Adjustment plates for front and rear rack installation	2-pack	BSP-ADPLATE*

*Note: BSP-ADPLATE encloses the gap between two SecurePatch covers installed back to back on a 3" deep equipment rack. When the adjustment plates are installed, inside usable mounting space is reduced by 2U.

Faster.
Easier.
Better.



2- and 4-Post Distribution Rack Systems

Modular High Density Racking System (HDRS) for network cross-connect

Applications

These high-reliability products have been designed specifically for networking environments – from Telecom closets to world-class Data Centers – to help you make the best use of valuable real estate and simplify MACs (Moves, Adds and Changes).

The HDRS is a well-engineered cross connect and hosting platform that offers you a high level of versatility and flexibility in systems design for ultimate network density and manageability.

How It Works

Create exactly the racking system you need from our selection of steel and aluminum distribution and server racks, combined with more than 50 standard cable management components and accessories. These items have been designed for complete compatibility and integration. The components include:

- Distribution and server racks in aluminum or steel; knockdown or welded; 2 or 4 posts
- Choice of low- or high-density vertical cable managers in single- or double-sided configurations
- High-density vertical manager half door allows easy cable access and hinging of the doors to both right and left side
- Horizontal cable managers with bend radius control and double-hinge cover
- **Accessories:** Retention Gates, Divider Bars, Transition Channels and more

How To Order

Select any of the Distribution and Server Rack styles. Select any of the Vertical Cable Managers listed for Distribution and Server Racks.

Choose any of the Accessories for the BHV Vertical Managers, Horizontal Managers or Transition Channels (See pages 44–45 for Technical Specifications and Options Tables).



HDRS Modular High-Density Racking System

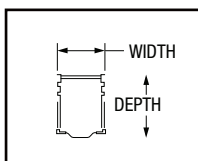

Single-Sided

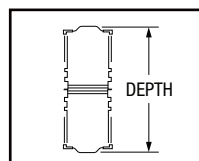

Double-Sided

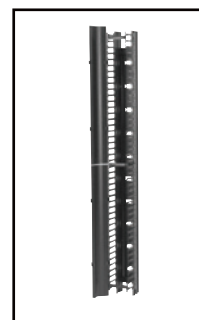

BHVH006*
High-Density, Single-Sided
Vertical Manager

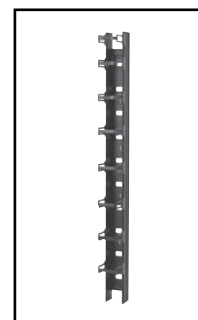

BHVL006*
Low-Density, Single-Sided
Vertical Manager

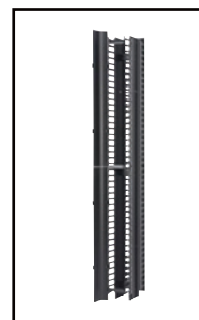

BHVHH06
High-Density, Double-Sided
Vertical Manager

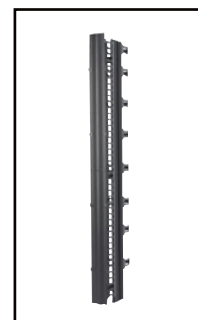

BHVHL06
High/Low-Density, Double-
Sided Vertical Manager

*High- and low-density vertical manager shown here with optional back covers, BHBV06X.

HDRS Vertical Manager Capacity

Single-Sided Manager				# of Cable 35% Fill	
High	Low	Width (in.)	Depth (in.)	Cat 6 0.250" dia.	Cat 6A 0.295" dia.
BHVH003	BHVL003	3.6	8.75	194	126
BHVH006	BHVL006	6	8.75	321	209
BHVH010	BHVL010	10	8.75	535	348
BHVH012	BHVL012	12	8.75	642	417

Double-Sided Manager				# of Cable 35% Fill	
High/High	High/Low	Width (in.)	Depth (in.)	Cat 6 0.250" dia.	Cat 6A 0.295" dia.
BHVHH03	BHVHL03	3.6	13.75	388	252
BHVHH06	BHVHL06	6	13.75	642	417
BHVHH10	BHVHL10	10	13.75	1070	696
BHVHH12	BHVHL12	12	13.75	1283	835



2- and 4-Post Distribution Rack Systems (continued) High-Density Racking System Features

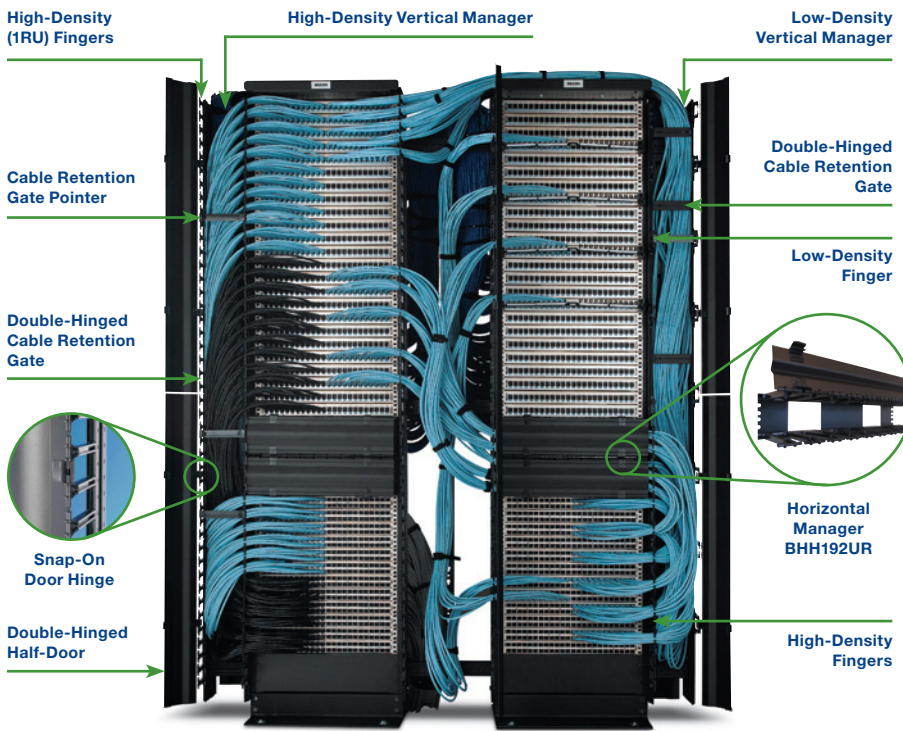

Racks and Cabinets

Vertical Manager Part Sets

- Includes a complete set of necessary components, including doors (on high-density managers), gates, push-in fasteners, cable strap mounts, cable retainer bars and mounting hardware

Modular, Removable Finger Sections

- Available in high or low density, finger sections can be easily removed during reconfigurations and easily replaced as needed
- High-density 11RU sections easily screw into vertical managers and align with the rack units, eliminating horizontal managers

System Scalability

- The HDRS is easily reconfigured and modified to handle future system growth, add-ons or changes

Compatibility of Vertical Managers

- Compatible with any EIA-310-D compliant 2- and 4-post racks

Mixed Media Application

- Designed to handle both copper and optical fiber structured cable networks

Accessory Mounting Holes

- 1/4" diameter mounting holes along length of each vertical manager enable easy attachment of accessories, like cable bundle fasteners

Any-Point-to-Any-Point Routing Capability

- Cable can be easily routed from one patch panel to another within the same rack, to the back of the rack or to an adjacent rack, while still maintaining proper cable bend radius

Easy Installation

- Only standard hand tools are required for quick installation and simple field reconfiguration and modification

Great Aesthetics

- Professional flat-black finish is suitable for any world-class telecom environment
- Central Office white color option allows for seamless integration where light-color cabinets are used, improving visibility

Unmatched Density

- Designed to work seamlessly with Belden IBDN copper and fiber systems, cable management fingers align with rack RUs for easy routing of patch cords to vertical managers, eliminating the need for horizontal managers

High Level of Modularity

- Enables ease of removal or reconfiguring Belden's wide selection of accessories and components
- Interchangeable cable retention gates, doors, fingers and accessories adapt to specific needs

Faster.
Easier.
Better.



2- and 4-Post Distribution Rack Systems (continued)
Suitable for single-rack to multi-rack high-density cross-connect

Applications

Belden offers a complete line of open racks and rack accessories from single-rack applications (Retail, Telecom closet) to high-density, multi-rack patching and switching fields (Computer Room, Data Centers, Central Offices). Belden's unique cable and connectivity expertise was central in the design of a feature-rich racking system that offers ease of installation, ease with MACs and is highly scalable.

Rack Features: 2- and 4-Post

- EIA-310 compliant, choice of 19" and 23" mounting
- Consult customer service for 23" rack and accessories (horizontal managers)
- Equipment mounting hardware is included
- 2-post rack uprights are front and rear tapped
- Easy rack unit identification for faster install
- Grounding stud standard on all 2-post and 4-post racks
- Steel or aluminum construction
- Seismic certified options
- Knockdown or welded construction
- 4-post racks are adjustable, providing for 28", 32" and 36" depths

Color

- Black (Standard)
- Central Office White available on request



Zone 4 Seismic-Rated Distribution Rack Type XDRS
Part No. Shown: XDRS8419-610

Dimensions

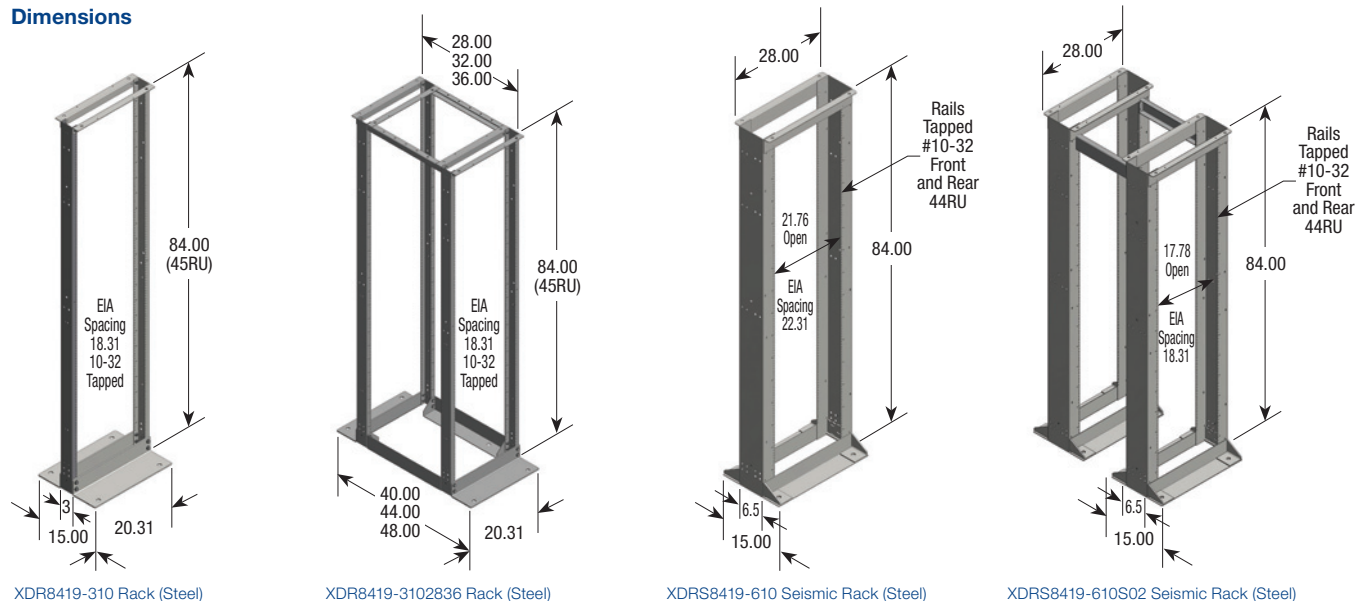

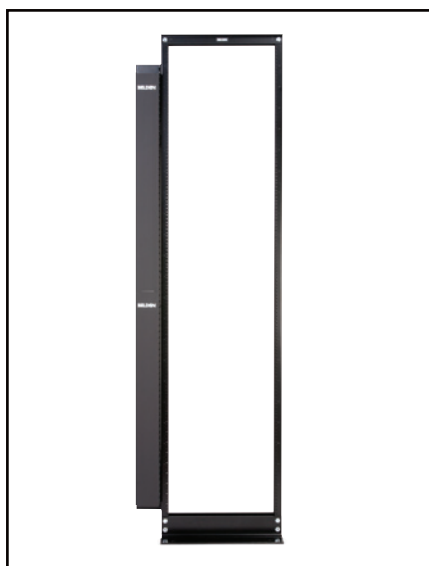

XDR8419-310N1M and XDR8419-312N1M



XDR8419-310N2M and XDR8419-312N2M

2- and 4-Post Distribution Rack Systems (continued)

Technical Specifications

Ordering Information

Description	Weight	Mounting**	Load Capacity	Height/Rack Spaces	Belden Part Number
2-Post Distribution Racks – Steel – Knockdown*					
#10-32 Tapped 3" Vertical Upright w/Angle Base	63 lbs	19"	1,000 lbs	84"/45RU	XDR8419-310
#12-24 Tapped 3" Vertical Upright w/Angle Base	63 lbs	19"	1,000 lbs	84"/45RU	XDR8419-312
Value Series Rack, #10-32 Tapped 3" Vertical Upright w/Angle Base	63 lbs	19"	1,000 lbs	84"/45RU	XDR8419-310N
Value Series Rack, #12-24 Tapped 3" Vertical Upright w/Angle Base	63 lbs	19"	1,000 lbs	84"/45RU	XDR8419-312N
2-Post Distribution Racks Kit – Steel – Knockdown*					
Value Series Rack Kit, #10-32 Tapped 3" Vertical Upright w/Angle Base, Includes One 4" x 4" Vertical Manager with Snap-On Cover (part # VCMFDR4X4)	76 lbs	19"	1,000 lbs	84"/45RU	XDR8419-310N1M
Value Series Rack Kit, #10-32 Tapped 3" Vertical Upright w/Angle Base, Includes Two 4" x 4" Vertical Manager with Snap-On Cover (part # VCMFDR4X4)	89 lbs	19"	1,000 lbs	84"/45RU	XDR8419-310N2M
Value Series Rack Kit, #12-24 Tapped 3" Vertical Upright w/Angle Base, Includes One 4" x 4" Vertical Manager with Snap-On Cover (part # VCMFDR4X4)	76 lbs	19"	1,000 lbs	84"/45RU	XDR8419-312N1M
Value Series Rack Kit, #12-24 Tapped 3" Vertical Upright w/Angle Base, Includes Two 4" x 4" Vertical Manager with Snap-On Cover (part # VCMFDR4X4)	89 lbs	19"	1,000 lbs	84"/45RU	XDR8419-312N2M
2-Post Distribution Racks – Steel – Welded					
#10-32 Tapped 3" Vertical Upright w/Angle Base – Welded	66 lbs	19"	1,000 lbs	84"/45RU	XDR8419-310W
#12-24 Tapped 3" Vertical Upright w/Angle Base – Welded	66 lbs	19"	1,000 lbs	84"/45RU	XDR8419-312W
2- and 4-Post Zone 4 Seismic Distribution Racks – Steel – Welded***					
2-Post Seismic Rack, #10-32 Tapped 6" Vertical Upright w/Angle Base	105 lbs	19"	900 lbs	84"/45RU	XDRS8419-610
4-Post Seismic Rack, 28" Deep, #10-32 Tapped 6" Vertical Upright w/Angle Base	215 lbs	19"	900 lbs	84"/45RU	XDRS8419-61028
4-Post Seismic Rack, 32" Deep, #10-32 Tapped 6" Vertical Upright w/Angle Base	220 lbs	19"	900 lbs	84"/45RU	XDRS8419-61032
2-Post Distribution Racks – Aluminum – Knockdown*					
#12-24 Tapped, Black, Knockdown 3" Vertical Upright	30 lbs	19"	1,200 lbs	84"/45RU	BHRR194
#12-24 Tapped, Black, Knockdown 6" Vertical Upright	41 lbs	19"	1,200 lbs	84"/45RU	BHRR6194
4-Post Distribution Racks – Steel – Knockdown*					
4-Post Rack with Adjustable Depth 28"-32"-36", #10-32 Tapped 3" Vertical Upright w/Angle Base	115 lbs	19"	1,500 lbs	84"/45RU	XDR8419-3102836
4-Post Rack with Adjustable Depth 28"-32"-36", #12-24 Tapped 3" Vertical Upright w/Angle Base	115 lbs	19"	1,500 lbs	84"/45RU	XDR8419-3122836
4-Post Server Rack – Steel – Welded****					
XHM Series Black Frame with (4) Adjustable Mounting Rails, Square Hole Type with 6 mm Mounting Hardware Included. Frame Size 24"W x 42"D x 85.6"H (45RU), Includes Levelers and Casters	240 lbs	19"	2,000 lbs	85"/45RU	X3M45-1-100000

* Knockdown rack shipped not assembled, assembly hardware is included

** For EIA-23" mounting consult Belden customer service

*** 4-post seismic rack is made of two welded 2-post rack structures, linked with front to rear member, shipped unassembled

**** 4-post server rack is not compatible with vertical managers (see page 45)

Faster.
Easier.
Better.

2- and 4-Post Distribution Rack Managers and Accessories



Ordering Information

Description	Belden Part Number
Vertical Cable Managers	
Value Vertical Manager with Snap-On Cover 4"W x 4"D	VCMFDR4X4
Single-Sided High-Density Vertical Manager w/Doors, 3 5/8"W x 84"H, Black	BHVH003
Single-Sided High-Density Vertical Manager w/Doors, 6"W x 84"H, Black	BHVH006
Single-Sided High-Density Vertical Manager w/Doors, 10"W x 84"H, Black	BHVH010
Single-Sided High-Density Vertical Manager w/Doors, 12"W x 84"H, Black	BHVH012
Single-Sided Low-Density Vertical Manager w/o Doors, 3 5/8"W x 84"H, Black	BHVL003
Single-Sided Low-Density Vertical Manager w/o Doors, 6"W x 84"H, Black	BHVL006
Single-Sided Low-Density Vertical Manager w/o Doors, 10"W x 84"H, Black	BHVL010
Single-Sided Low-Density Vertical Manager w/o Doors, 12"W x 84"H, Black	BHVL012
Double-Sided High-Density Vertical Managers w/Doors, 3 5/8"W x 84"H, Black	BHVH003
Double-Sided High-Density Vertical Managers w/Doors, 6"W x 84"H, Black	BHVH006
Double-Sided High-Density Vertical Managers w/Doors, 10"W x 84"H, Black	BHVH010
Double-Sided High-Density Vertical Managers w/Doors, 12"W x 84"H, Black	BHVH012
High/Low-Density Vertical Manager w/Front Door, 3 5/8"W x 84"H, Black	BHVH003
High/Low-Density Vertical Manager w/Front Door, 6"W x 84"H, Black	BHVH006
High/Low-Density Vertical Manager w/Front Door, 10"W x 84"H, Black	BHVH010
High/Low-Density Vertical Manager w/Front Door, 12"W x 84"H, Black	BHVH012
Accessories for BHV Vertical Managers	
3 5/8"W, Black, Vertical Manager Backcover	BHBC03X
6"W, Black, Vertical Manager Backcover	BHBC06X
10"W, Black, Vertical Manager Backcover	BHBC10X
12"W, Black, Vertical Manager Backcover	BHBC12X
3 5/8"W, Black, Vertical Manager Doors (1 pr)	BHDK03X
6"W, Black, Vertical Manager Doors (1 pr)	BHDK06X
10"W, Black, Vertical Manager Doors (1 pr)	BHDK10X
12"W, Black, Vertical Manager Doors (1 pr)	BHDK12X
Slack Management Spool Kit, Black	BHSG020
Slack Management Spools (2), Black	BHSP020
Gate Kit, 3 5/8"W, Black	BHGL03X
Gate Kit, 6"W, Black	BHGL06X
Gate Kit, 10"W, Black	BHGL10X
Gate Kit, 12"W, Black	BHGL12X
Retention Gate (6) 3 5/8"W, Black	BHGR03X
Retention Gate (6) 6"W, Black	BHGR06X
Retention Gate (6) 10"W, Black	BHGR10X
Retention Gate (6) 12"W, Black	BHGR12X
Finger Section, 11U, Black	BHFS11U
Rack Mount Finger Bracket, 11U, Black	BHFB11U
Divider Bar, 3 5/8"W, Black	BHDB03X
Divider Bar, 6"W, Black	BHDB06X
Divider Bar, 10"W, Black	BHDB10X
Divider Bar, 12"W, Black	BHDB12X
Fastener for Vertical Manager (100)	BHPF100
Tie Mount for Vertical Manager (100)	BHSM100
Horizontal Manager with Cover	
19"W x 1RU, Black	BHH191UR
19"W x 2RU, Black	BHH192UR
19"W x 3RU, Black	BHH193UR
19"W x 4RU, Black	BHH194UR
1RU, Rack Mount, Finger Duct Manager 3.0"H x 3.0"D Deep with Cover	9512-1901
2RU, Rack Mount, Finger Duct Manager 3.0"H x 3.0"D Deep with Cover	9512-1902N
Transition Channel (Top transition channels are only compatible with knockdown racks)	
Top Transition Channel, 19"W x 6"D x 9"H, Black	BHTT196
Top Transition Channel High-Density, 19"W x 6"D x 6"H, Black	BHTTH196
Lower Transition Channel, 19"W x 6"D x 1.75"H, Black	BHTL196
Lower Transition Channel Double, 19"W x 6"D x 3.5"H, Black	BHTD196

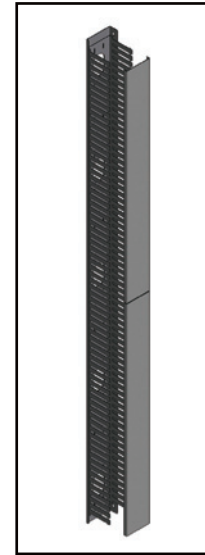

VCMFDR4X4

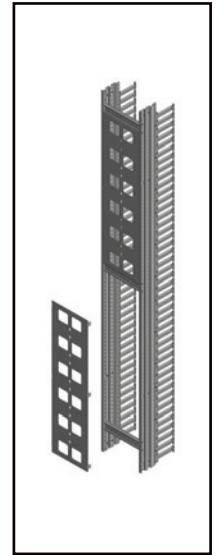

BHBC10X
(Vertical manager not included)



9512-1902N

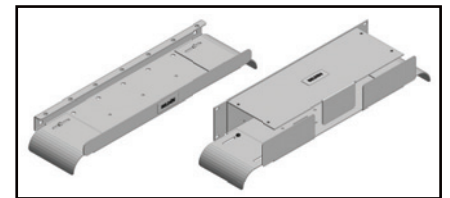

BHTT196 and BHTD196

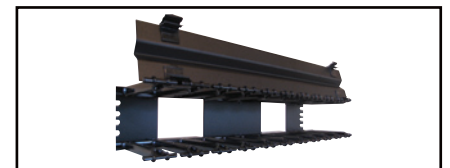

BHH192UC Horizontal Manager



XWR and XWB Series – Wall Mount Racks

Hinged and swing-out for rear access in tight spaces

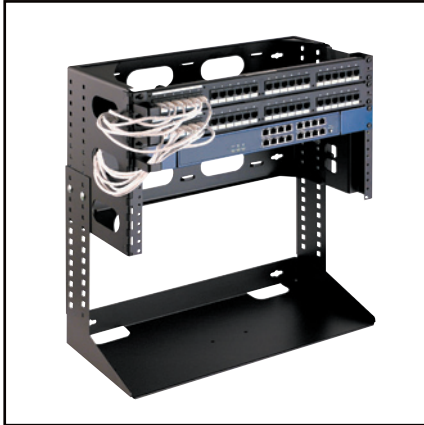

XWR-1219 Wall Mount Rack in Hinged Style
(shown in closed position with equipment mounted)

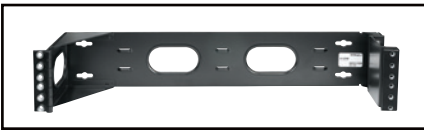

XWB-2U 2RU Wall Mount Bracket

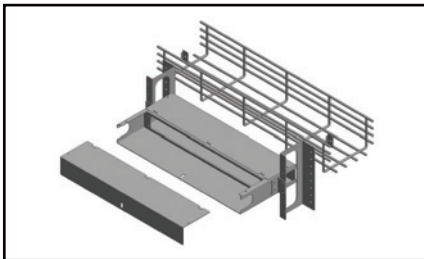

XPE-S0001 1RU rack attach to basket tray

Wall Mount Racks are available in two styles: hinged and swing-out. The hinged rack is 12" in height and features an adjustable lower shelf (adjusts 2" to 6"). The swing-out rack is available in heights of 36" and 48" with 19" mounting rails. 2RU, 4RU and 6RU Wall Mount Brackets are also offered for mounting a limited number of components or pieces of equipment.



XWR-3619-18 Swing-Out Style Wall Mount Rack

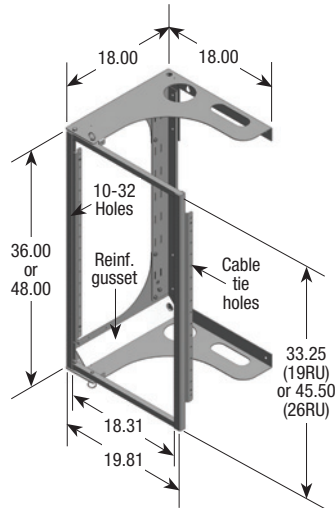

Heavy-Duty XWR Swing-Out Style Wall Mount Rack

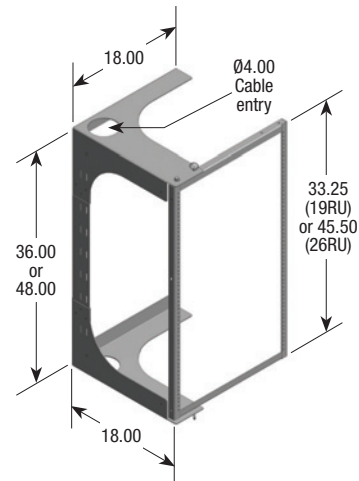

XWR Swing-out Style Wall Mount Rack

Ordering Information

Description	H	W	D	Weight	Mounting	Load Capacity	Rack Spaces	Belden Part Number
Wall Mount Racks								
Standard Swing-Out Rack: 36" Wall Mount Rack with 19" Mounting Rails	36"	19.75"	18"	30 lbs	19"	100 lbs	19RU	XWR-3619-18
Heavy Swing-Out Rack: 36" Wall Mount Rack with 19" Mounting Rails	36"	19.75"	18"	35 lbs	19"	200 lbs	19RU	XWR-3619-18HD
Standard Swing-Out Rack: 48" Wall Mount Rack with 19" Mounting Rails	36"	19.75"	18"	39 lbs	19"	100 lbs	26RU	XWR-4819-18
Heavy-Duty Swing-Out Rack: 48" Wall Mount Rack with 19" Mounting Rails	36"	19.75"	18"	40 lbs	19"	200 lbs	26RU	XWR-4819-18HD
Hinged Rack: 12" Wall Mount Rack, Hinged, 19" Mounting Rails, Adjustable Lower Shelf 2"–11" to Accommodate Equipment Space	10.9"	19.5"	9.5"	26 lbs	19"	50 lbs	6RU	XWR-1219
Wall Mount Brackets								
2RU Wall Mount Bracket, Black	3.5"	19"	8"	4 lbs	19"	50 lbs	2RU	XWB-2U
4RU Wall Mount Bracket, Black	7.0"	19"	8"	8 lbs	19"	50 lbs	4RU	XWB-4U
6RU Wall Mount Bracket, Black	10.50"	19"	8"	10 lbs	19"	50 lbs	6RU	XWB-6U
1RU rack, includes basket tray attachment hardware	2.0"	19"	N/A	12 lbs	19"	20 lbs	1RU	XPE-S0001

Faster.
Easier.
Better.



XSW Series – Swing Rack

Free-standing swing-out rack used where space is limited

The Swing Rack provides easy access to the rear of rack mounted equipment in a free-standing environment. It is ideal for applications where space is limited and rear access is essential.

- Rack can be assembled as a left or right hinge and open 90°
- Rack can be positioned as close as 7" from wall
- Equipment up to 18.5" deep can be pivoted
- Cable management allows for cable routing without interference of the swing rack
- Racks can be bolted side-to-side
- Friction lock prevents rack movement while servicing

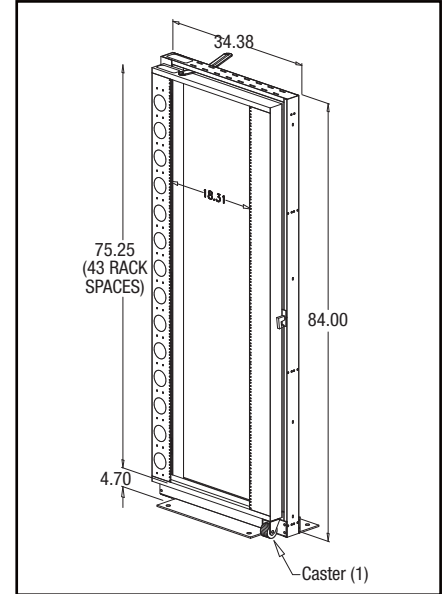
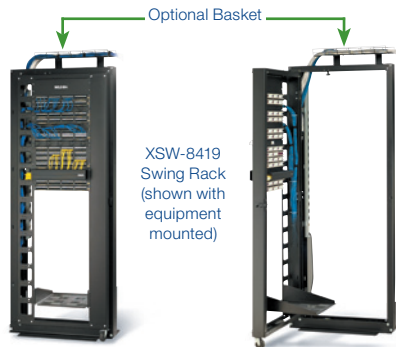
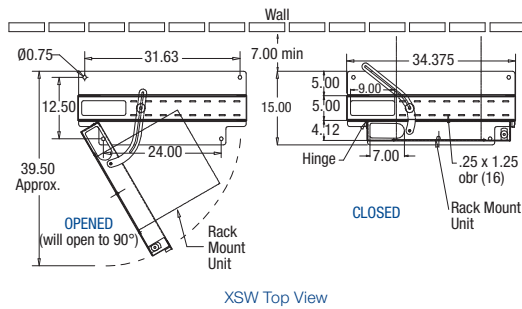

XSW Front View

Ordering Information

Description	Weight	Mounting	Load Capacity	Rack Spaces	Belden Part Number
Swing Racks					
84" Swing-Out Distribution Rack	179 lbs	19"	500 lbs	34RU	XSW-8419
Accessories (Sold Separately)					
Top Mounting Wire Basket	—	—	—	—	XSW-0200
Power Strip Mounting Kit	—	—	—	—	XSW-0100



SECTION TWO

Broadcast Racks and Cabinets

Table of Contents	Page
Broadcast Racks and Cabinets	50-64
Advantages	50-53
Comparison Chart	53
XSF Series — Slim Frame for Mobile Broadcast/Telecom Applications	54-55
XMF Series — Media Frame for Broadcast Applications	56-58
XME Series — Media Cabinet for Broadcast, Audio Video and Security Applications	59-61
XMER Series — Media Cabinet for Broadcast, Audio Video, Security and Head End Applications	62-64



Engineered for Performance and Ease of Installation for Broadcast, Audio Video, Security, Head End and Mobile Telecom Applications

Belden offers four series of **high-quality Racks and Cabinets** for your unique Entertainment, Security, Head End and Mobile Telecom applications.

Belden has designed its Broadcast, Audio Video and Security Rack/Cabinet Series using the same top-quality and user-friendly principles that go into all of our market-leading solutions.

These uncompromisingly strong and well-built structures are combined with component features that optimize cable performance and provide extraordinary flexibility in cable management. These features provide a unique approach to equipment housing and storage needs.

The following pages detail the breadth of our rack/cabinet offering for the Entertainment, Security and Broadcast industries. In addition, Belden offers a complete array of shelves for 19" mount racks and cabinets, including cantilevered, 4-point mount, sliding and keyboard-type shelves.

Faster.
Easier.
Better.



Advantages in Using Belden Broadcast Rack and Cabinet Series



Construction

- Welded frame construction for greater strength and structural integrity is standard on all broadcast racks and cabinets

Accessories

- A full complement of accessories will outfit your cabinets with the needed mounting, shelving, work surface and cable management support

Ease of Installation

- EIA rails are marked with rack space increments for ease of equipment mounting

Cable Management

- Numerous top and bottom entry points simplify cabling
- The rounded, steel-formed cable tie bar (Photo A) reduces pressure points
- The multiple attachment points for our Quick Mount System – or Nylon ties along the mounting rails, rail supports and cable tie bar (Photos B and C) – provide the utmost flexibility in cable routing and lacing
- The Quick Mount fastening system (Photo D) is comprised of a unique swivel base and base fastener. Velcro ties are easily threaded through the fastener base, allowing the cable bundles to be secured to the rack. The system's swivel base allows for a 90° angle between the cable bundle and the cable tie to allow pressure distribution along the cables

Aesthetics

- Powder coating process provides a textured black finish for a highly resistant, high-end look that showcases your equipment
- Aesthetics can be tailored to your requirements with a variety of doors, panels and customized silk screening options

Temperature Control

- Perforated and vented doors, along with a variety of top panel options, provide flexible cooling options

Power Distribution

- A complete line of Belden power distribution units, including rack mount and vertical mount options, can be found on [pages 69–76](#)
- Grounding studs allow for integral grounding of cabinets and accessories

Seismic Rating

- XME and XMER Series include NEBS seismic rating when anchored with optional seismic anchor bracket kit



The cabinet shown here is the XMER Style (Media Cabinet)



Photo A



Photo C



Photo B



Photo D

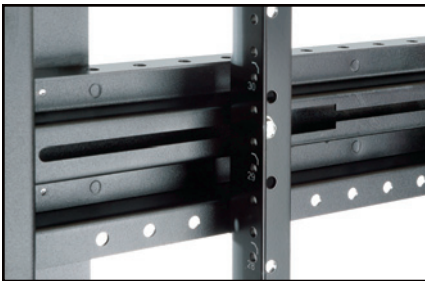

EIA Rail Kits

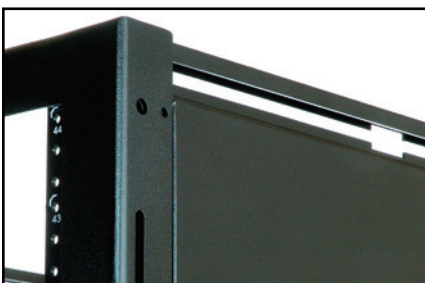

Side Panels

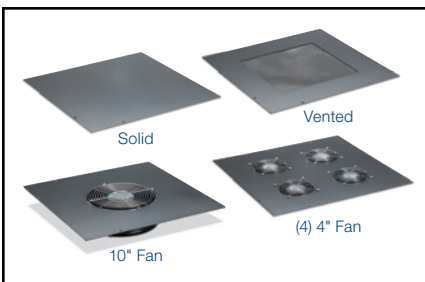

Top Panels

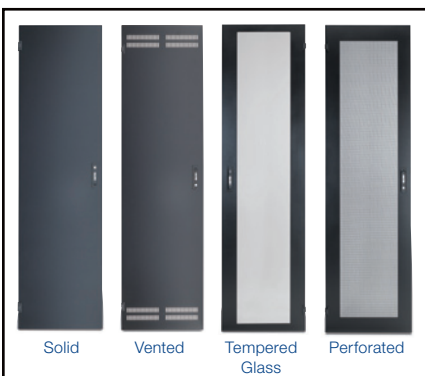

Doors

Advantages in Using Belden Broadcast Rack and Cabinet Series (continued)

Features and Benefits

EIA Rail Kits

- Rails are made of 12-gauge steel (XSF uses 16-gauge steel)
- Use standard EIA-310 hole-pattern (10-32 or 12-24 tapped holes)
- Fully adjustable depth; designed to be moved without need to remove rail support hardware
- Mounting hardware supplied with rack
- A series of lacing holes along the rails allow for the easy attachment of cables. Holes are also compatible with our Quick Mount fasteners
- RU marking on all rails facilitates equipment mounting
- RU marks are hidden once the equipment is mounted

Side Panels

- The tool-less surface-mounted side panels are quick and easy to install
- Flush version side panels (available only on the XMF Series) can be installed in between joined racks (heat barrier) or end-of-row units without any additional floorspace requirements
- Panels can be used to transform a rack into a free-standing cabinet or to close a row on ganged racks (enhancing the installed look and providing added security)
- Feature lifting handles for easy panel removal

Top Panels

- Solid tops prevent dust from entering the cabinet
- Vented tops allow for convection cooling
- Solid top with 10" (550 CFM) fan for forced hot air evacuation
- Solid top with four 4" (320 CFM), low noise fans for forced hot air evacuation

Doors

- Rugged and rigid construction
- Doors mounted with lift-off hinges are capable of 180° swing, even when cabinets are ganged
- Door swing is field reversible
- Glass door uses anti-static tempered glass, allowing easy cleaning, rigidity and high-end look
- Perforated door features 63% mesh opening allowing for minimal air resistance for optimized cooling
- High-quality swing latch includes locking mechanism



Side Cable Chase

(Available on XMER Series)

- Adds 4" of valuable cable management space
- Can be mounted to the side of the cabinet and is compatible with the side panels – or can be mounted in between the cabinets to share cable management space



Base

- 4" riser base allows for easy cable routing from rack to rack
- Available in XMF Series: gangable 1-, 2- and 3-bay bases with easy-to-use anchoring holes
- Series of mounting holes allow rack to be secured using common nuts and bolts
- Feature power outlet mounting openings with cover plate
- Includes mounting hardware and grounding stud
- Multi-rack riser bases to meet your specific space requirements (length, height) are available on custom basis

Recessed Caster Base

- Allows for easy positioning of the rack
- Installs directly to bottom flanges of cabinet
- Recessed casters allow the leveling legs to be lowered when the cabinet is in position and raises the casters off the floor
- Includes hardware



Rack Mount Drawer

- Convenient sliding storage drawers
- 16" deep with lock
- Available in four heights



Front Mount Work Surface

- Provides a convenient work surface
- 16" deep, single-bay (22") and double-bay (44") width



Faster.
Easier.
Better.



Advantages in Using Belden Broadcast Rack and Cabinet Series (continued)

Features and Benefits



Vertical Lacing Bar

- 1" wide vertical lacing bar is supplied with mounting hardware
- Mounts to the rail supports; fully adjustable depth
- Series of lacing holes are compatible with Belden Quick Mount fasteners to provide flexibility in cable routing



Vertical Lacing Panel

- Mounts to the rail support
- Fully adjustable depth
- Panel is 3" wide and features multiple lacing points
- Ideal for attaching cable bundle



Power Distribution Units

- Extensive offering
- Includes monitored and IP-based smart PDUs
- Climate monitoring option available



(See page 78)

Grounding Provision

- Belden racks are provisioned with grounding studs, enabling integral grounding of rack and accessories
- The copper vertical ground bar mounts to the rack support
- Fully adjustable depth
- Bar is 3/4" wide x 1/8" thick



Quick Mount Fasteners

- Velcro hook and loop with cable tie mount and fasteners provide a quick, flexible way to route the cable bundle within the rack
- Racks are designed with multiple attachment holes (rails, rail supports) for flexibility, ease of installation and to protect cable integrity



Shelves

- Broad selection for 19" mount racks and cabinets
- Cantilevered, 4-point mounted, sliding and keyboard styles

(See page 64)

Belden Broadcast Rack and Cabinet Series Comparison Chart



pg. 52



pg. 54



pg. 57



pg. 60

Specifications		XSF	XMF	XME	XMER
Application		Broadcast, Mobile Telecom, Space Optimization	Broadcast	Broadcast, Audio Video, Security	Broadcast, Audio Video, Security, Head End
Style		Rack Gangable	Rack/Cabinet Stand-Alone or Gangable	Cabinet with Fixed Side Panels Stand-Alone or Gangable	Rack/Cabinet Stand-Alone or Gangable
Dimensions:	Height	20.5"-87" (10-48RU)	22.25"-103" (11-57RU)	48.87"-83.87" (24-44RU)	48.87"-83.87" (24-44RU)
	Width	19.19"	22"	22"	22"
	Depth	18", 24" or 30"	24", 30", 36" or 40"	20" or 26.5"	26.5", 31.5" or 36"
Frame Construction (Fully Welded)		11-Gauge Steel	11- and 14-Gauge Steel	16-Gauge Steel	14- and 16-Gauge Steel
Front and Rear Mounting Rails		Yes: Tapped Corner Posts, (fixed front), Adjustable Rear Rails (5/8" increments)	Yes Fully Adjustable	Yes Fully Adjustable	Yes Fully Adjustable
EIA-310 Compliant		Yes (#10-32 or 12-24 tapped)	Yes (#10-32 or 12-24 tapped)	Yes (#10-32 tapped)	Yes (#10-32 tapped)
Door Options:	Reversible Front and Rear Doors	No	Yes	Yes	Yes
	Solid, Perforated or Tempered Glass	—	Solid or Vented	Yes	Yes
Top Options		No	Solid, Vented, Forced Air Fan	Solid, Vented, Forced Air Fan	Solid, Vented, Forced Air Fan
Side Panel Options:	Removable	No	Yes	No: Fixed	Yes
	Panel Style	—	Flush or Surface Mount	Built-In Frame	Surface Mount
Shelves (Solid, Vented and Keyboard)		Yes	Yes	Yes	Yes
Caster Base Option		No	Yes	Yes	Yes
Power Strip Mounting Provision		Yes	Yes	Yes	Yes
Cable Management Tie Bar		No	Yes, Optional	No	Yes, Optional



XSF Series – Slim Frame

Light and customizable frames for Broadcast Trucks and Mobile Telecom

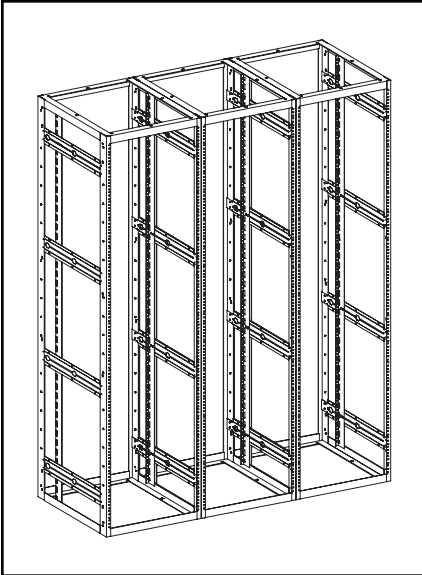

XSF Series Racks in ganged arrangement



Part No. shown here: XSF473010000
(47RU H x 19.19"W x 30"D)

Applications

The ultra-slim XSF frame has been designed to minimize the footprint for installation and use in mobile TV trucks. The narrow 19.19" width will accommodate standard 19" mount equipment. The frames gain strength when ganged together in a series.

Design and Structural Features

- Available in 14 heights and 3 depths
- 11-gauge steel, one-piece formed top and bottom; 11-gauge steel formed vertical corner posts
 - 20.5" (10RU) to 87" (48RU) Height x 19.19" Wide x 18", 24" or 30" Deep
- Optional aluminum, weight-saving version available on request
- Front corner post contains EIA-310 hole pattern: 10-32 or 12-24 tapped
- Rail support channels are 16-gauge steel, riveted and welded in place

Ease of Installation

- One pair, 16-gauge steel EIA rails, moveable front to rear in .62" increments
- Each frame is supplied with 10-32 or 12-24 clip nuts for attaching equipment to the rails
- Holes in side flanges of each corner post are available for ganging purposes
- Open bottom with hole pattern to bolt frame to floor; captive grounding studs in bottom sills

Color

- Black durable powder coat

Faster.
Easier.
Better.



Ordering Matrix for XSF Series

Part number example:

XSF282410000

XSF Cabinet, 28RU, 24" depth, with 10-32 tapped frame, no top panel, no rear panel, and no side panels.

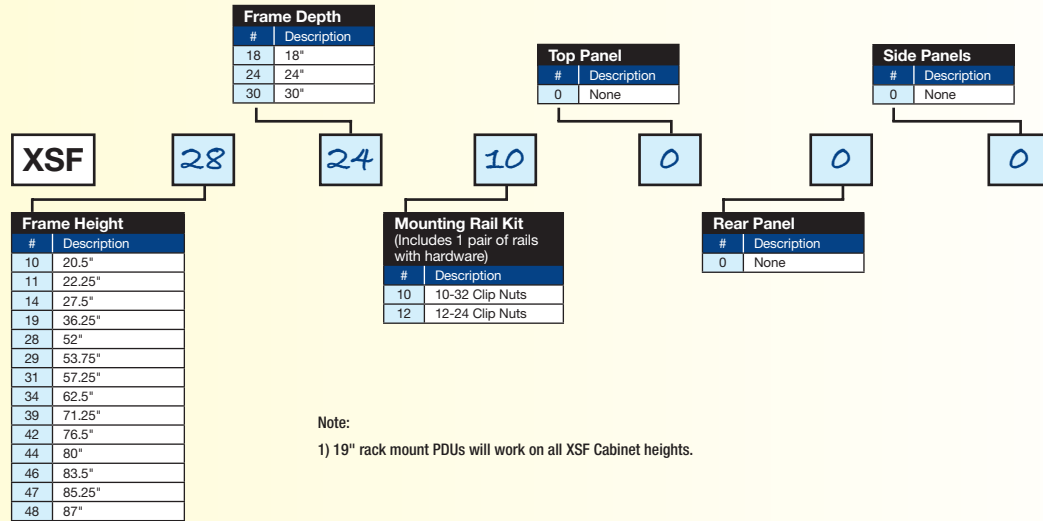

Broadcast Racks and Cabinets

XSF Series – Options and Accessories

EIA Rail Kit – 1 Pair
Includes mounting hardware.

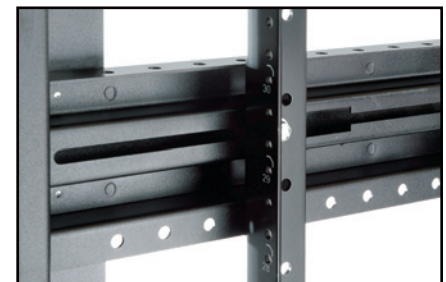
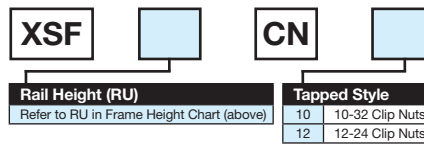

EIA Rail Kit – 1 pair with hardware

Description	Belden Part Number
Other Accessories	
Lacing Accessories	
Quick Mount with Fastener, 10 Pieces	XMFCTM



XMF Series - Media Frame

Flexible cable management in a narrow frame for Broadcast Studios



Part No. shown here: XMF4424100000TB
(44RU H x 22" W x 24" D)



Part No. shown here: XMF4424102140
(44RU H x 22" W x 24" D)

Cable Management

- Numerous lacing points on two surfaces of each rail support
- Cable tie holes span entire length of EIA rail on the attachment flange (spaced at 1.75")
- Unique cable tie bar is made of formed steel to eliminate sharp edges; provides multiple attachment points; features cable bend radius control and lacing holes; factory mounted when tie bar option is selected

Design and Structural Features

- Available in 26 heights and 4 depths for versatility in designing studios or production facilities
- 11-gauge steel corner posts; 11-gauge formed top and bottom members; 14-gauge formed rail supports
 - 22.25" (11RU) to 103" (57RU) Height x 22" Wide x 24", 30", 36" or 40" Deep
- (4) 12-gauge EIA mounting rails (10-32 or 12-24 tapped)
- Frame is provisioned to accept optional front and rear doors, side and top panels
- **Reversible Doors:** Surface mount solid, 16-gauge doors or top and bottom vented styles
- **Side Panel:** Solid, 16-gauge flush side panel or 1-piece formed surface mount panel; surface mount panels add 1/2" per side to overall width
- **Top Panel:** Solid, vented or with 10" fan
- **Vertical Spacing Panel:** Easy-to-install; 2.75", 3.66", 4.40" and 5.50" widths; 11RU-57RU heights
- **Riser Base:** 4" height, 1-3 bays; fully-welded, gangable; power outlet openings with covers; anchoring holes supplied to ease installation
- **Caster Base:** Recessed; 20", 30", 36" and 40" depths; adds 2.5" to frame height; caster bases install directly to bottom flanges of cabinets; casters are recessed, enabling leveling legs to be lowered when cabinet is in position, allowing the casters to be raised off the floor
- **Rack-Mount Drawers:** 16" deep sliding storage drawers with lock; available in four heights; mount on EIA rails (mounting hardware included); compatible with all 19" mount racks

Ease of Installation

- Frame is provisioned for attaching a tool-less, formed surface mount side panel or a flat, flush panel. Flush side can be installed between joined cabinets without any additional floorspace
- Vertical spacing panels add cable management space between racks; includes two panels with attachment studs; panel features lifting handles
- Open top with optional configurable panels
- Open bottom with hole pattern to bolt frame to floor or a raised base; captive grounding studs in bottom sills
- Ganging can be done after equipment is placed in rack

Color

- Black durable powder coat

Faster.
Easier.
Better.



Ordering Matrix for XMF Series

Part number example:

XMF443012104TB

XMF Cabinet, 44RU height, 30" depth, with 10-32 tapped frame, vented top panel, solid swing front door, no rear door, set of surface mount side panels, no power strip, tie bar.

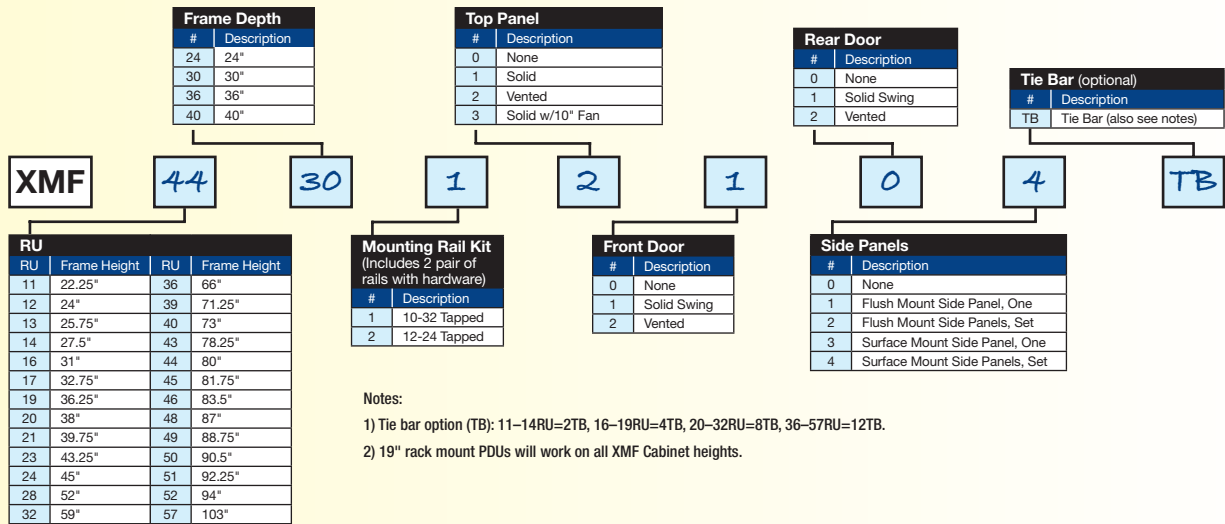

Broadcast Racks and Cabinets

XMF Series – Options and Accessories

Refer to RU and FRAME DEPTH charts (above).

Top Panel Options

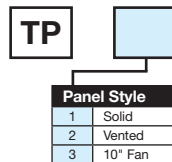
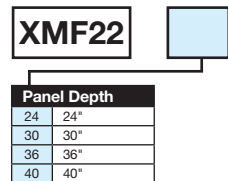

Base Options

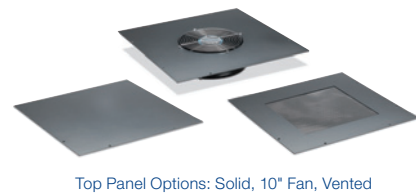
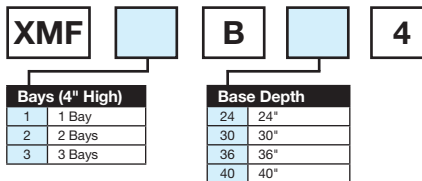

Recessed Caster Base

Use of caster base adds 2.5" to cabinet height.

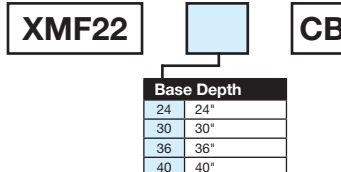

Base Options: 1 Bay, 2 Bays, 3 Bays and Recessed Caster Base



XMF Series – Options and Accessories (continued)

Refer to RU and FRAME DEPTH charts (on previous page).



EIA Rail Kits

EIA Rail Kits – 1 Pair

Includes mounting hardware.

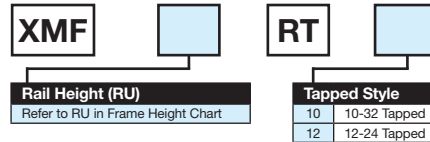

Vertical Spacing Panel

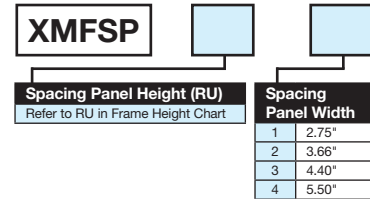

Doors

Door Options

Compatible with cabinet front or rear.

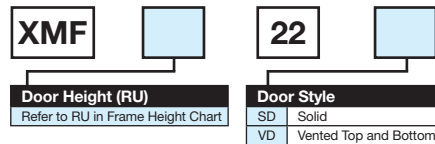

Vertical Lacing Bar



Vertical Ground Bar

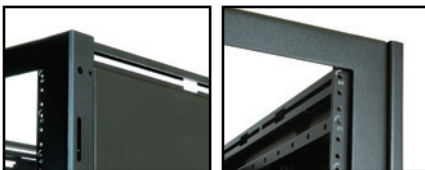

Side Panel Options: Flush Flat Panel (left), Formed Surface Mount Panel (right)

Side Panel Options

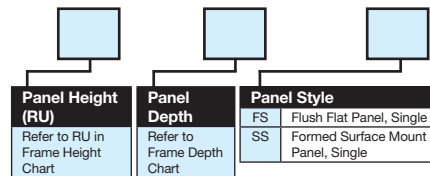

Vertical Lacing Panel



Quick Mount System Components XMFCTM

Description	Belden Part Number
Other Accessories	
Lacing Accesories	
Quick Mount with Fastener, 10 Pcs.	XMFCTM
Velcro 12" Long, Hook and Loop, 10 Pcs./Kit	XCTV12
Velcro 18" Long, Hook and Loop, 10 Pcs./Kit	XCTV18
Velcro 24" Long, Hook and Loop, 10 Pcs./Kit	XCTV24
Seismic Anchor Bracket Kit	
Seismic Anchor Bracket Kit	XMFSB
Adjoining Kits	
Bolt-Together Kit for Frames (incl. hardware)	XMFBK01
Kit for Loaded Rack Application	XMFBK02
Bolt-Together Kit for Bay Bases (incl. hardware)	XMFBK03
Edge Guard Kits (for use with Base Bolt-Together Kit)	
24"D, 30"D (1 base cutout)	XMFEG01
36"D, 40"D (1 base cutout)	XMFEG02

Faster.
Easier.
Better.



XME Series – Media Cabinet

Cost effective and efficient design for Broadcast, Commercial AV and Security applications



Design and Structural Features

- Available in four heights and two depths
- 16-gauge, one-piece formed and vented sides; 16-gauge formed bottom and top
 - 48.87" (24RU) to 83.87" (44RU) Height x 22" Wide x 20" or 26.5" Deep
- Top and bottom EIA rail support channels are an integral part of the top and bottom; formed center rail support channels are spot welded to the sides
- Two 12-gauge EIA mounting rails (10-32 tapped); additional rails can be added (optional)
- Front and side ventilation for convection cooling
- Stand-alone or gangable, with integrated side panels
- **Reversible Doors:** Frame is available with optional front and rear solid, glass or perforated surface mount doors
- **Top Panel:** Solid, vented, with 10" fan or (4) 4" fans; depths of 20 and 26.5"
- **Caster Base:** Recessed, depths of 20" and 26.5"; adds 1" to height of frame; casters are recessed, allowing leveling legs to be lowered when cabinet is in position, allowing casters to be raised off the floor
- **Rack Mount Drawers:** 16" deep sliding storage drawers with lock; available in four heights; mount on EIA rails (mounting hardware included); compatible with all 19" mount racks

Cable Management

- **Rear Access** – Top: three antenna knockouts, each .62" dia. two conduit knockouts, .87" dia. and 1.12" dia. 9" x 2.25" opening with cover plate. Bottom: 4 conduit knockouts, two @ .87" dia., two @ 1.12" dia. 9" x 2.25" opening with cover plate
- **Side Access** – Top: 4" dia. knockout, located toward the rear. Bottom: 4" dia. knockout, located toward the rear. Optional edge guard to protect the cable is available
- **Top Access** – 1", 1.5" and 2" knockouts, located toward the rear of top panel
- Cable tie holes span entire length of EIA rail on the attachment flange (spaced at 1.75")
- Fully open top and bottom facilitate cable routing

Ease of Installation

- Partially open top with optional configurable panels; rear of top contains various electrical knockouts for cable entry
- Open bottom with leveling legs and hole pattern to bolt frame to floor, captive grounding studs in bottom sills
- Ganging can be done after equipment is placed in rack



Part No. shown here: XME442641310
(44RU H x 22" W x 26" D)

Color

- Black durable powder coat



Part No. shown here: XME44260001
(44RU H x 22" W x 26" D)

Ordering Matrix for XME Series

Part number example:

XME44203131

XME Cabinet, 44RU height, 20" depth, with 10" fan top panel, glass swing front door, perforated swing rear door, and two fixed vented side panels.

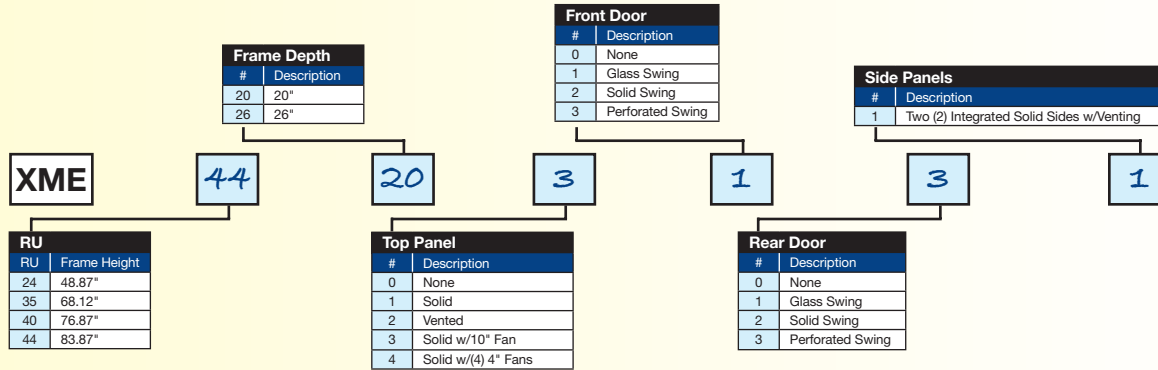

Note:

1) 19" rack mount PDUs will work on all XME Cabinet heights.

XME Series – Options and Accessories

Refer to RU and FRAME DEPTH charts (above) as needed.

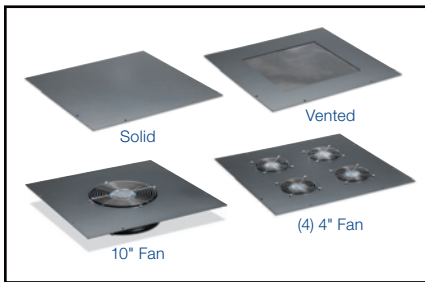

Top Panels

Top Panel Options

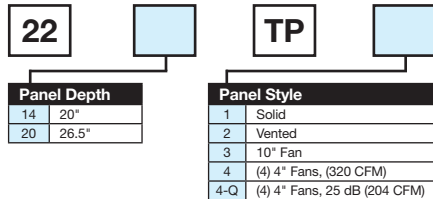

Door Options

Compatible with cabinet front or rear.

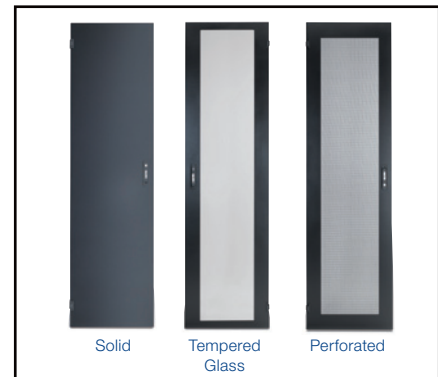
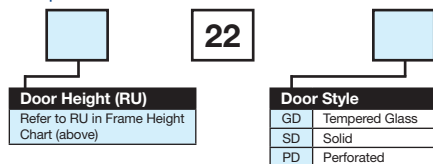

Doors

Faster.
Easier.
Better.



XME Series – Media Cabinet Options and Accessories (continued)



Refer to RU and FRAME DEPTH charts (on previous page).

Front Mount Work Surface

For standard 19" mounting.

XMEW

Work Surface	
22	1 Bay, 22"
44	2 Bays, 44"

Vent Kits

Allows for top vent to be blocked to optimize forced air cooling (fanned top).

XME

Vent Kit	
SVC	Side Vent Cover Kit. Plate to Block Off Vents in Side
FVC	Front Vent Cover Kit. Plate to Block Off Vents in Front

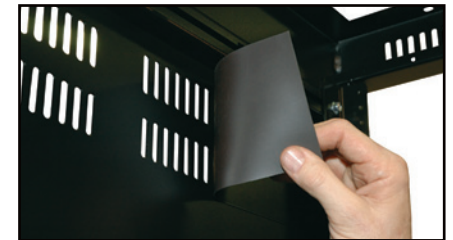

Vent Kits

Vertical Lacing Panel

LP

Lacing Panel			
24	24RU	40	40RU
35	35RU	44	44RU

EIA Rail Kits – 1 Pair with Hardware

XMER

Rail Height (Frame HT)	
24	48"
35	67.5"

RT10



EIA Rail Kits

Recessed Caster Base

22

Base Depth	
20	20"
26	26"

CB1

Rack Mount Drawers

For standard 19" mounting.

RMD

Drawer Height	
2	2RU
3	3RU



Rack Mount Drawers

Description	Belden Part Number
-------------	--------------------

Other Accessories

Lacing Accessories	
Quick Mount with Fastener, 10 Pcs.	XMFCM
Velcro 12" Long, Hook and Loop, 10 Pcs./Kit	XCTV12
Velcro 18" Long, Hook and Loop, 10 Pcs./Kit	XCTV18
Velcro 24" Long, Hook and Loop, 10 Pcs./Kit	XCTV24
Rack Mount Lacing Bar	
Rack Mount Lacing Bar	9512-1903
Top Mounted Ladder Rack Support	
Top-Mounted Ladder Rack Support	XMELM
Adjoining Kit	
(4) 1/4" Whiz Bolt and Whiz Nuts	XMEBK01
Grounding Kit	
Straps and 1/4" Wing Nuts	XMEGK01
Edge Guard Kits	
Edge Guard Kit	XMEEG01
Seismic Anchor Bracket Kit	
Seismic Anchor Bracket Kit	XMERSB



Quick Mount Swivel Base Fastener XMFCM



XMER Series - Media Cabinet

Flexible and economical design for Broadcast, Commercial AV, Security and Head End applications



Part No. shown: XMER44310000
(44RU H x 22" W x 31.5" D)



Part No. shown: XMER4431320
(44RU H x 22" W x 31.5" D)

26.5", 31.5", or 36" (depth)
22" (width)

Design and Structural Features

- Available in four heights and three depths; taller units (48RU, 50RU and 52RU) available on demand
- 14-gauge, one-piece formed top and bottom; 16-gauge formed vertical corner posts
 - 48.87" (24RU) to 83.87" (44RU) Height x 22" Wide x 26.5", 31.5" or 36" Deep
- EIA rail support is integral part of the top and bottom with spot-welded inner support channel
- Middle rail support channels are spot-welded construction of two 16-gauge formed rail channels, creating .12" thick support channels per side
- (4) 12-gauge EIA mounting rails (10-32 tapped)
- **Reversible Doors:** Frame available with optional front and rear solid, glass or perforated surface mount doors
- **Side Panels:** Surface mount removable side panels, adds 1/2" to overall width
- **Top Panel:** Solid, vented, with 10" fan or (4) 4" fans; depths of 26.5", 31.5" and 36"
- **Side Cable Chase:** 4" wide chase for added cable management; can be mounted between cabinets or used as side unit; will accept a side panel (44RU cabinets only)
- **Caster Base:** Recessed, depths of 26.5", 31.5" and 36"; adds 1" to frame height. Caster bases install directly to bottom flanges of cabinets; casters are recessed, allowing leveling legs to be lowered when cabinet is in position, and casters to be raised off floor

48.87"
83.87"

Cable Management

- **Rear Access** — Top: three antenna knockouts, each .62" dia. two conduit knockouts, .87" dia. and 1.12" dia. 9" x 2.25" opening with cover plate; Bottom: four conduit knockouts, two @ .87" dia., two @ 1.12" dia. 9" x 2.25" opening with cover plate
- **Side Access** — Top: 4" dia. knockout, located toward rear; Bottom: 4" dia. knockout, located toward rear; optional edge guard to protect the cable available
- **Top Access** — 1", 1.5" and 2" knockouts, located toward rear of top panel
- Lacing points on two surfaces of each rail support facilitate cable management
- Cable tie holes span entire length of EIA rail on attachment flange (spaced at 1.75")
- Cable tie bar made of formed steel, eliminates sharp edges; provides multiple attachment points; features cable bend radius control and lacing holes; factory mounted when tie bar option is selected

Color

- Black durable powder coat

Ease of Installation

- Open top with optional configurable panels
- Open bottom with leveling legs and hole pattern to bolt frame to floor; captive grounding studs in bottom sills
- Ganging can be done after equipment is placed in rack

Faster.
Easier.
Better.



Ordering Matrix for XMER Series

Part number example:

XMER40362232

XMER Cabinet, 40RU height, 36" depth, with vented top panel, solid swing front door, perforated swing rear door, and two solid side panels.

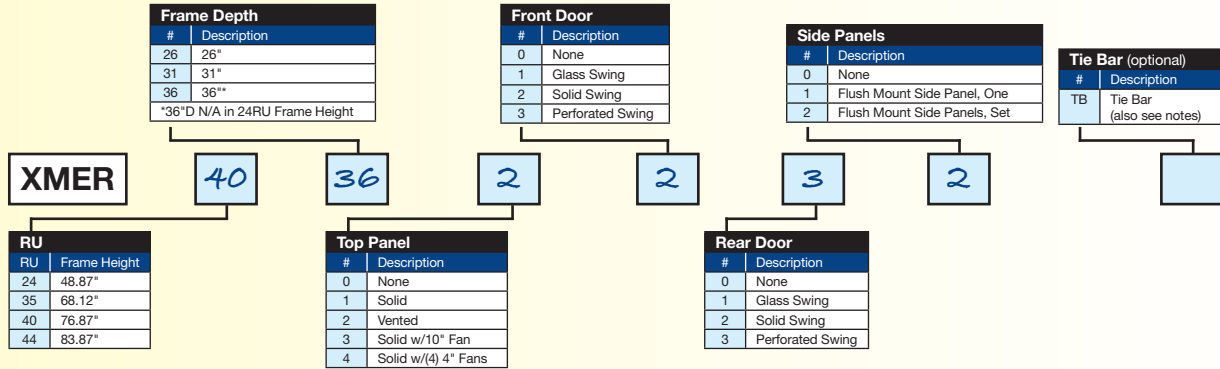

Notes:

- 1) Tie bar option (TB) 24RU=8TB, 35-40-44RU=12TB.
- 2) 19" rack mount PDUs will work on all XMER Cabinet heights.

XMER Series – Options and Accessories

Refer to RU and FRAME DEPTH charts (above).

Top Panel Options

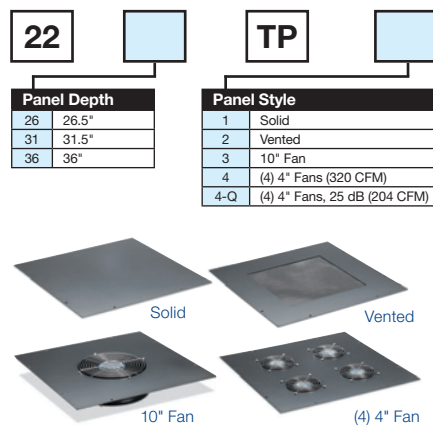

Door Options

Compatible with cabinet front or rear.

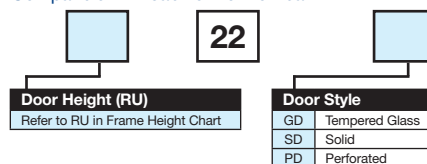

Side Panel Options

Solid removable (single).

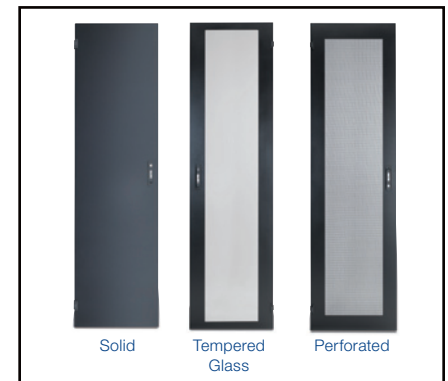
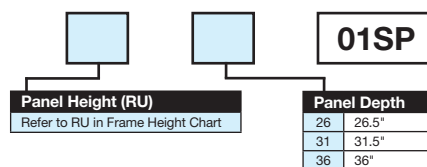

Doors



XMER Series – Options and Accessories (continued)

Refer to RU and FRAME DEPTH charts (on previous page).

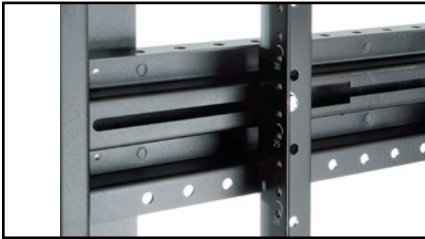

EIA Rail Kits

EIA Rail Kits – 1 Pair with Hardware



Rail Height (Frame HT)			
24	48"	40	76"
35	67.5"	44	83"

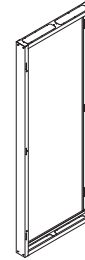

Side Cable Chase (4" Wide)



Chase Depth	
26	26.5" (RU44)
31	31.5" (RU44)
36	36" (RU44)



Rack Mount Drawers

Rack Mount Drawers

For standard 19" mounting.



Drawer Height			
2	2RU	4	4RU
3	3RU	5	5RU



Vertical Lacing Panel



Lacing Panel			
24	24RU	40	40RU
35	35RU	44	44RU

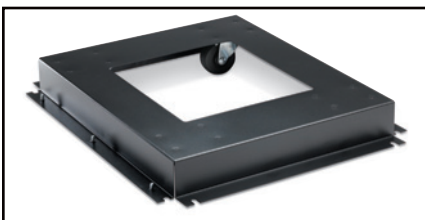

Recessed Caster Base

Recessed Caster Base



Base Depth	
26	26"
31	31"
36	36"



Front Mount Work Surface

For standard 19" mounting.



Work Surface	
22	1 Bay, 22"
44	2 Bays, 44"

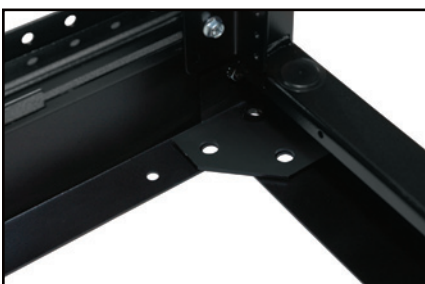

Seismic Anchor Bracket Kit

Description	Belden Part Number
-------------	--------------------

Other Accessories

Lacing Accessories

Quick Mount with Fastener, 10 Pcs.	XMFACTM
Velcro 12" Long, Hook and Loop, 10 Pcs./Kit	XCTV12
Velcro 18" Long, Hook and Loop, 10 Pcs./Kit	XCTV18
Velcro 24" Long, Hook and Loop, 10 Pcs./Kit	XCTV24

Rack Mount Lacing Bar

Rack Mount Lacing Bar	9512-1903
-----------------------	-----------

Top-Mounted Ladder Rack Support

Top-Mounted Ladder Rack Support	XMELM
---------------------------------	-------

Adjoining Kit

(4) 1/4" Whiz Bolt and Whiz Nuts	XMEBK01
----------------------------------	---------

Grounding Kit

Straps and 1/4" Wing Nuts	XMEGK01
---------------------------	---------

Seismic Anchor Bracket Kit

Seismic Anchor Bracket Kit	XMERSB
----------------------------	--------

SECTION THREE

Components and Accessories

Table of Contents

Page

Components and Accessories

65-70

Cabinet Shelves	66
Horizontal Cable Management	67
Light Kits	68
Filler Panels	68
Grounding and Bonding	69
Mounting and Adjoining Hardware	69
Cabinet Access Systems	70



Large Selection of Rack and Cabinet Accessories to Meet Equipment Mounting, Cable Management, Grounding/Bonding and Access Control Challenges

Components and accessories designed for seamless compatibility with Belden racks and cabinets products.

- Cantilevered and 4-point mount shelf mounting options for non-rack mount components
- Organize and manage patch cords and cables with horizontal managers available in multiple sizes and capacities
- Optimize air separation for improved availability with solid and brushed filler panels
- Ensure installation security and electrical conformance with bonding and grounding products
- Meet active equipment mounting requirements with multiple mounting hardware products
- Access control for cabinets protects your physical assets and data

Remotely manage server access

while maintaining an indisputable audit trail with Belden Cabinet Access Systems.

Cabinet Shelves 19" Shelves

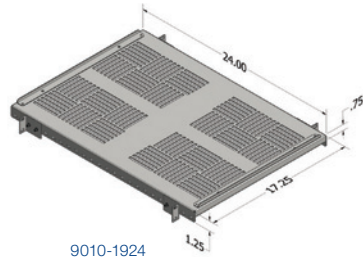

9010-1924

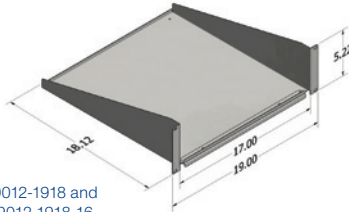

9012-1918 and
9012-1918-16

Features

- Compatible with 19" mount Racks and Cabinets (23" mount option available on request)
- Available in depths of 12" to 36" cantilevered or 4-point mount types
- Shelves include mounting hardware
- Load ratings range from 25 lbs to 200 lbs
- Standard shelf color is black (other colors are available on custom basis for volume orders)

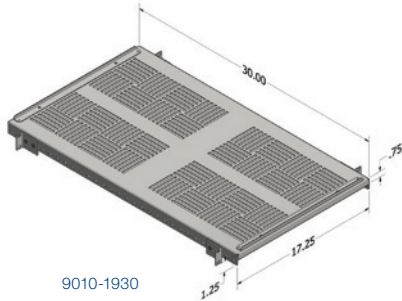

9010-1930

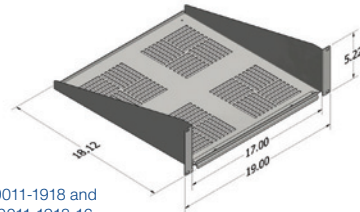

9011-1918 and
9011-1918-16

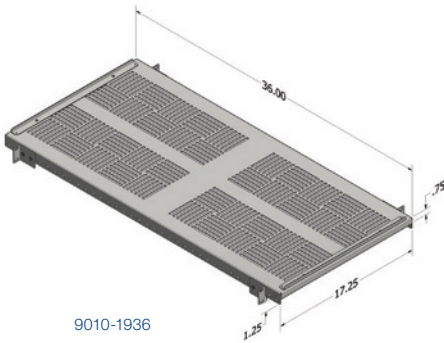

9010-1936

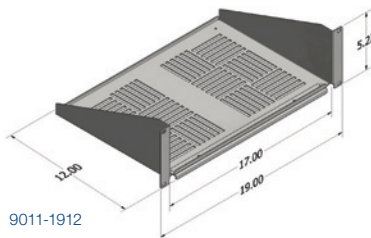

9011-1912

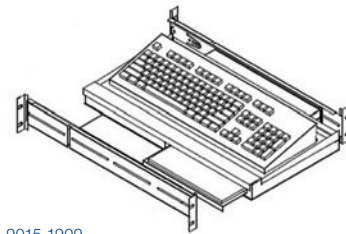

9015-1909

Technical Specifications

Description	Depth*	Load Rating	Belden Part Number
19" Heavy-Duty Adjustable Shelf (Vented), 4-Point Mounting	24"	150 lbs	9010-1924
19" Heavy Duty Adjustable Shelf (Vented), 4-Point Mounting	30"	150 lbs	9010-1930
19" Heavy Duty Adjustable Shelf (Vented), 4-Point Mounting	36"	150 lbs	9010-1936
19" Flush Mount Cantilevered Shelf (Vented) – Compatible with 27.5" Deep Wall Mount Cabinets	12"	50 lbs	9011-1912
19" Flush Mount Cantilevered Shelf (Vented)	18"	50 lbs	9011-1918
19" Flush Mount Cantilevered Shelf (Vented)	18"	25 lbs	9011-1918-16
19" Flush Mount Cantilevered Shelf (Solid)	18"	50 lbs	9012-1918
19" Flush Mount Cantilevered Shelf (Solid)	18"	25 lbs	9012-1918-16
19" Heavy-Duty Sliding Adjustable Shelf (Vented), 4-Point Mounting	24"	100 lbs	9013-1924
19" Sliding Rotating Keyboard Shelf	N/A	N/A	9015-1909

Note:

*Compatibility with cabinet frame size to be validated when selecting shelf depth.

Faster.
Easier.
Better.



Horizontal Cable Management

Application

Horizontal managers allow routing of copper and fiber cables/patch cords in racks and cabinets while helping to maintain proper bend radius and organize array for ease of moves, adds and changes.

Features include:

- 1RU to 4RU height
- 19" mount includes mounting hardware
- Compatible with racks and cabinets
- Selection of ring, finger and cable tie bar style horizontal managers
- Standard color is black (other colors available on volume orders)



Top: 9512-1901, Bottom: 9512-1902



9510-1901

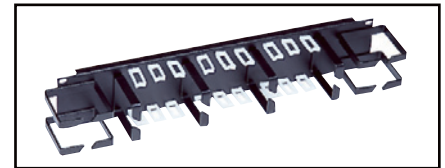

9511-1902

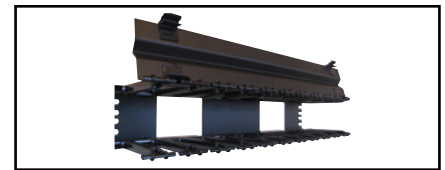

BHH192UC Horizontal Manager

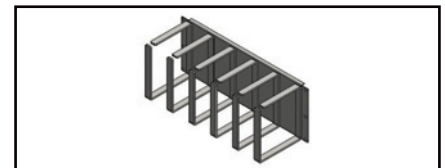

9511-1904-01

Horizontal Managers

Description	RU	Manager Cross Section	Belden Part Number
Horizontal Manager with Saddle Rings	1RU	1.65"H x 3"D	9510-1901
Horizontal Manager with Saddle Rings	2RU	3"H x 3"D	9511-1902
Horizontal Manager with Finger Stock and Cover	1RU	1.5"H x 2"D	9512-1901
Horizontal Manager with Finger Stock and Cover	2RU	3"H x 3"D	9512-1902N
Horizontal Manager with Finger Stock and Cover, Front & Rear	2RU	3"H x 3"D Front/Rear	9512-1902-FR
Horizontal Manager with Molded Fingers and Hinging Cover, Enclosure Application	1RU	1.75"H x 5.66"D	BHH191UC
Horizontal Manager with Molded Fingers and Hinging Cover, Enclosure Application	2RU	3.5"H x 5.66"D	BHH192UC
Horizontal Manager with Molded Fingers and Hinging Cover, Enclosure Application	3RU	5.25" x 5.66"D	BHH193UC
Horizontal Manager with Molded Fingers and Hinging Cover, Enclosure Application	4RU	7" x 5.66"D	BHH194UC
Horizontal Manager with Molded Fingers and Hinging Cover, Open Rack Application	1RU	1.75"H x 7.22"D	BHH191UR
Horizontal Manager with Molded Fingers and Hinging Cover, Open Rack Application	2RU	3.5"H x 7.22"D	BHH192UR
Horizontal Manager with Molded Fingers and Hinging Cover, Open Rack Application	3RU	5.25" x 7.22"D	BHH193UR
Horizontal Manager with Molded Fingers and Hinging Cover, Open Rack Application	4RU	7" x 7.22"D	BHH194UR
Horizontal Cable Tie Bar with 1.5" Deep Offset	1RU	N/A	HCB-1932-1.5-01
Horizontal Cable Tie Bar with 2.5" Deep Offset	2RU	N/A	HCB-1932-2.5-01
Horizontal Ring Style Manager, High Capacity, Open Rack Application	2RU	3.5"H x 6.8"D	9511-1902-01
Horizontal Ring Style Manager, High Capacity, Open Rack Application	3RU	5.25"H x 6.8"D	9511-1903-01
Horizontal Ring Style Manager, High Capacity, Open Rack Application	4RU	6.9"H x 6.8"D	9511-1904-01

Light Kits



9420-1905



9420-1906

Construction

- Light Kits are compatible with all 19" mount racks or cabinets
- Uses one (1) rack unit
- Includes 120V AC adapter and mounting hardware

Options

Description	Belden Part Number
Dual Adjustable 5W Halogen Lights & Dimmer, UL Listed	9420-1905
Single Adjustable 5W Halogen Light & Dimmer, UL Listed	9420-1906



Steel Filler Panels



Plastic Filler Panel

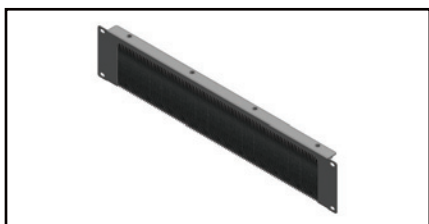

XFPWB2U101
Brushed filler panel allows routing of cable from front to rear while providing air flow separation. Panel is open ended, allowing mounting without having to unplug cables.

Filler Panels

Application

- Filler Panels allow blocking of unused rack units (RU) for optimized airflow and separation between cold supply air and hot return air
- Best practices in Data Centers includes blanking of all unused rack units (RU)
- Filler Panels are compatible with 19" mount racks and cabinets

Description	Color	Belden Part Number
-------------	-------	--------------------

Options

Filler Panels, Steel (includes Mounting Hardware)

1RU Solid Filler Panel	Black/CO White	9910-0100-01/-02
2RU Solid Filler Panel	Black/CO White	9911-0200-01/-02
2RU Solid Filler Panel with "Belden" Logo Silk Screen	Black	9911-0201-01
3RU Solid Filler Panel	Black/CO White	9912-0300-01/-02
4RU Solid Filler Panel	Black/CO White	9913-0400-01/-02
8RU Solid Filler Panel	Black/CO White	9914-0800-01/02

Filler Panels, Plastic Tool-Less

1RU Solid Filler Panel (fits 10-32, 12-24 and square holes rails)	Black/CO White	9910-0100PL-01/-02
2RU Solid Filler Panel (fits 10-32, 12-24 and square holes rails)	Black/CO White	9911-0200PL-01/-02

Filler Panels with Brush Pass Thru (includes Mounting Hardware)

1RU Filler Panel with Brush (open ended)	Black/CO White	XFPWB1U101/02
2RU Filler Panel with Brush (open ended)	Black/CO White	XFPWB2U101/02
3RU Filler Panel with Brush (open ended)	Black/CO White	XFPWB3U101/02
4RU Filler Panel with Brush (open ended)	Black/CO White	XFPWB4U101/02

Faster.
Easier.
Better.



Grounding and Bonding

Options

Description	Belden Part Number
19" Horizontal Isolated Copper Ground Bar, .25" Thickness x 1" W, Tapped 10-32	9714-0190
Grounding/Bonding Strap Kit (11" strap with hardware)	XBS-11-0001
Grounding/Bonding Strap Kit (18" strap with hardware)	XBS-18-0002
Grounding/Bonding Strap Kits	
Bonding Strap Kit (11" strap with hardware and anti-oxidation compound)	XBS-11-0001
Bonding Strap Kit (18" strap with hardware and anti-oxidation compound)	XBS-18-0001
Grounding Lug Kit (Ground Lug and 1/4-20 Kep Nut)	20128-KIT

Notes:

Bonding strap kit is included with cabinet doors, sides and top panels.
Grounding lug kit is for use with rack and cabinet welded ground studs.

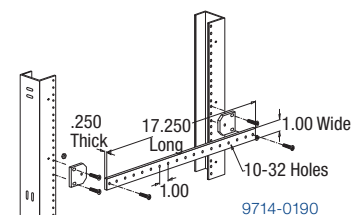

19" mount grounding bar is 0.25" thick x 1.25" wide, with #10-32 tapped holes; isolating mounts with hardware are included.

Mounting Hardware

Application

Included adjoining hardware for ganging of racks and cabinets, plus a variety of bolts, screws and nuts for mounting of active and passive networking devices into Racks and Cabinets.

Description	Quantity/Package	Belden Part Number
10-32 Hardware		
10-32 Mounting Screws	50	8911-0100
10-32 Cage Nuts (for use with square hole rails)	50	8915-0100
10-32 Cage Nuts (for use with square hole rails)	20	8915-0220
10-32 Clip Nuts	20	8915-0320
12-24 Hardware		
12-24 Mounting Screws	50	8917-0100
12-24 Cage Nuts (for use with square hole rails)	50	8917-0220
12-24 Clip Nuts	20	8917-0320
M6 Hardware		
M6 Cage Nut (for use with square hole rails)	50	8913-0100
M6 Cage Nut (for use with square hole rails)	20	8913-0220
M6 Clip Nut	20	8913-0320
M6 x 16 mm Mounting Screw	50	8914-0100
Cable Ties		
Velcro Cable Ties, 8"L x 0.5"W, 25 per Roll	25	AX100783
Velcro Cable Ties, 12"L x 0.5"W, 25 per Roll	25	AX100784
12" Fiber Optic Cable Manager	1	AX102516
24" Fiber Optic Cable Manager	1	AX102517
Quick Mount Velcro Saddle with Fastener	10	XMFCTM



AX102516 Cable Slack Management Ring - 12" diameter

Adjoining Hardware

Description	Cabinet Series	Belden Part Number
Cabinet Adjoining Kit (4) 5/16-18 Hex Head Bolt; (4) 5/16-18 Hex Nut; (8) 5/16 Flat Washer	XS, XN, XHM, XSS, XNX	8910-0100
Cabinet Adjoining Kit for NEMA 12 (4) 5/16-18 Hex Head Bolt; (4) 5/16-18 Hex Nut; (8) 5/16 Flat Washer, includes Gasketing	XNM	XNM-0100
Bolt-Together Kit for XSF Frames (incl. hardware)	XSF	XSF BK01
Adjoining Kit (4) 1/4-20 x 5/8 Carriage Bolt; (4) 5/16 External Tooth Lock Washer; (4) Whizlock Nuts	XMF	XMFBK01
Loaded Rack Application Bolt Kit (4) 12-24 x 1 3/4 Screw; (8) External Tooth Washer; (4) 12-24 Hex Nuts; (4) .5 x .125"W Tubing Nylon	XMF	XMFBK02
Adjoining Kit (4) 1/4-20 x 5/8 Whizlock Bolt; (4) 1/4-20 Whizlock Nut	XME, XMER	XMEBK01
Joining Kit (4) 5/16 x 1 Bolt, (8) 5/16 Washers, (4) 5/16 Nuts	—	XBK01

Note:

Adjoining hardware is included with the cabinets.

Cabinet Access Systems

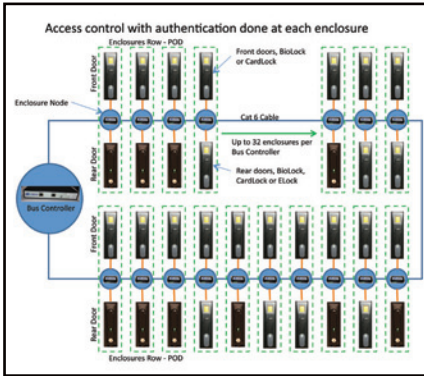

Access control with authentication done at each cabinet

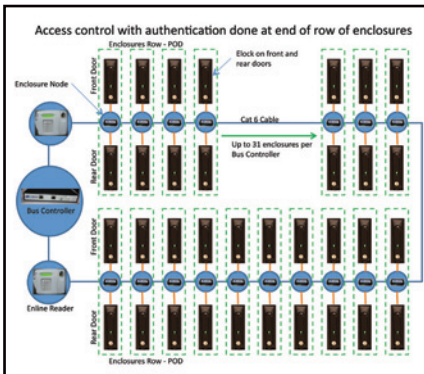

Access control with authentication done at end of row of cabinet



8815-0210 BUS Enline Reader w/PIN and Fingerprint



iClass Card, Biometrics and E-Lock Handle Options

Application

Physical assets protection/access is key to IT operations, such as Data Centers, Enterprise and Remote Computing locations. Belden cabinets can be equipped with a variety of locking handles, including state-of-the-art cabinet access control and management solutions, allowing conformance to privacy rules and regulations (PCI DSS, HIPAA, FISMA and more).

Features

- Centralized administration of up to thousands of units
- Real-time monitoring and alerts
- Indisputable audit trails
- Cabinets or row/pod level access
- Flexibility to choose between fingerprint or RFID card access

Stand alone cabinet access systems are for smaller or distributed installations. Each cabinet has a dedicated controller and biometric (BioLock) or card reader (CardLock) used for user authentication.

In a networked cabinet access system, a central controller distributes control signals and power to up to 32 cabinets when authenticating at the cabinet level and 31 cabinets when authenticating at the end of row. For cabinet level authentication, choose between fingerprint (BioLock) or RFID card (CardLock). For end-of-row authentication, the user enters which cabinet door they are attempting to access, then uses any combination of PIN, RFID card and fingerprint to authenticate.

Description	Belden Part Number
Locking Swing Handles	
Swing Handle (1) w/Common CH-751 Lock Cylinder/Key, w/Belden Logo Silk Screen	8815-0100
Swing Handle (1) w/Special Non CH-751 Lock Cylinder/Key, w/Belden Logo Silk Screen	8815-0101
Swing Handle (1) w/Key Lock and Padlock Loop (1), Padlock Not Included	8815-0102
Swing Handle (1) w/3 Digit Combination Lock and Key Override	8815-0103
Smart Lock/Access System	
BUS Controller, includes 48 VDC PSU, 2 x 14' CAT 6 Cable	8815-0200
End of Rows Reader	
BUS Enline Reader w/PIN and Fingerprint	8815-0210
BUS Enline Reader w/PIN, Fingerprint and HID ICLASS 13.56 MHz	8815-0211
BUS Enline Reader w/PIN, Fingerprint and HID 125 KHz	8815-0212
Cabinets Level & Row Level Access Systems - Networked application	
Cabinet Node w/1 Biolock Swing Handle	8815-0221
Cabinet Node w/1 Biolock and 1 Elock Swing Handle	8815-0222
Cabinet Node w/2 Biolocks Swing Handle	8815-0223
Cabinet Node w/1 Cardlock Swing Handle	8815-0224
Cabinet Node w/1 Cardlock and 1 Elock Swing Handle	8815-0225
Cabinet Node w/2 Cardlocks Swing Handle	8815-0226
Cabinet Node w/1 Elock Swing Handle	8815-0227
Cabinet Node w/2 Elocks Swing Handle	8815-0228
Cabinets Level Access Systems - Stand alone application	
Access Controller w/1 Cardlock, 18.5 V PSU, 1 Door Switch	8815-0240
Access Controller w/1 Cardlock, 1 Elock, 18.5 V PSU, 2 Door Switches	8815-0241
Access Controller w/2 Cardlocks, 18.5 V PSU, 2 Door Switches	8815-0242
Access Controller w/1 Biolock, 18.5 V PSU, 1 Door Switch	8815-0243
Access Controller w/1 Biolock, 1 Elock, 18.5 V PSU, 2 Door Switches	8815-0244
Access Controller w/2 Biolocks, 18.5 V PSU, 2 Door Switches	8815-0245
Software - Access Interface and Management	
Server/Client Software for Connection up to 10 Cabinets	8815-0280
Server/Client Software for Connection up to 50 Cabinets	8815-0282
Server/Client Software for Connection up to 100 Cabinets	8815-0283
Server/Client Software for Connection up to 250 Cabinets	8815-0284
Electronic Slide Handle	
Electronic Slide Handle (TZ compatible) with Multiport Link & Lock Cylinder	8815-0104

Note:
Includes door switch(es) and 14' of Cat 6 cables.



SECTION FOUR

Power Distribution & Climate Monitoring

Table of Contents

Page

Power Distribution & Climate Monitoring	71-80
Cabinet Power Distribution Units (PDUs)	72-73
Single-Phase Basic/Smart PDUs	74
3-Phase Basic/Smart PDUs	75
Single- and 3-Phase Switched PDUs	76
PDU Accessories — Mounting, Cord Management and Cord Set	77
PDU Configuration Guide	78
Plug and Receptacle Configuration Chart	79
Environmental Monitors and Sensors	80



Power Availability, Distribution, Allocation and Monitoring are Critical Data Center and Broadcast Studio Requirements

Precisely distribute, monitor, analyze and manage power distribution in your facility to **maximize processing capacity** and promote power efficiency.

Belden in-cabinet mounted Power Distribution Units (PDUs) and Environment Monitors and Sensors are designed from high-quality components to support all your mission critical applications.

A key component of our Data Center Ready Solution (DCRS), Belden PDUs allow configuration of integrated and optimized hosting systems, including fiber/copper connectivity and cabling, cabinets, cable management and air flow management. They are designed to facilitate seamless integration into Belden Racks and Cabinets, and include multiple mounting options for maximized air flow and cable management in high-density servers or switch hosting applications.

Paired with our extensive line of environmental monitors and sensors, which include alarm thresholds, reporting functionality, and a built-in intuitive web interface for remote access, Belden has everything you need to precisely monitor, analyze and log key parameters, enabling you to identify current fluctuations and quickly troubleshoot potential problems.

*Lacing-PDU mounting panels (p.75) are not included with the cabinets or the PDU's and need to be ordered separately. PDU's/panels uses tool less "button" style mounting.



Cabinet Power Distribution Units (PDUs)



XN Series cabinets with end-of-row and in between 6" extensions



Organized networking and power cable management for proper server airflow



Side-by-side PDU mounting using 7" wide PDU mounting panel (Part No. XVMP024501)

Belden PDU Options and Features

- All Belden PDUs are UL and cUL listed 60650
- Select from a wide offering of PDUs designed to meet your specific power requirements; single phase, 3-phase (WYE and Delta configurations)

Power	Amp	Voltage	Phase	Plug
3.3kW	20A	250V	1 Phase	L6-20P or 2P, 3W
5kW	30A	250V	1 Phase	L6-30P or 2P, 3W
11kW	20A	230/400V	3 Phase WYE	L22-20P or 4P, 5W
16.6kW	30A	230/400V	3 Phase WYE	L22-30P or 4P, 5W
1.4kW	15A	125V	1 Phase	5-15P or L5-15P
1.9kW	20A	125V	1 Phase	5-20P or L5-20P
2.8kW	30A	125V	1 Phase	L5-30P
5.7kW	20A	120/208V	3 Phase WYE	L21-20P
8.6kW	30A	120/208V	3 Phase WYE	L21-30P
8.6kW	30A	250V	3 Phase Delta	L15-30P
17.2kW	60A	208V	3 Phase Delta	3P/4W
23kW	80A	208V	3 Phase Delta	Hard Wired
34kW	120A	208V	3 Phase Delta	Hard Wired

- Over 500 standard PDUs available to ship within 10 days of ordering, or custom PDUs available to ship within 20 days of ordering
- C-13 and C-19 receptacles with optional locking feature for mission critical applications
 - Unplugging cords requires simple "push" of release button
 - Locking mechanism binds to the ground pin on the plug and is compatible with standard IEC cord, thus eliminating the need for expensive proprietary cords



Locking Receptacles

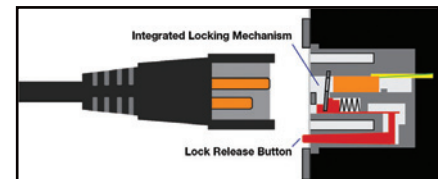

Inside View of Locking Mechanism

Faster.
Easier.
Better.



Cabinet Power Distribution Units (PDUs) (continued)



PDU Selection: Basic, with Local Monitoring and Intelligent

- PDU mounted display option for local current or power monitoring, making phase balancing easier (the PDU itself is not phase balancing)

Intelligent PDU Options and Features

- Remote aggregate, circuit or receptacle power monitoring for granular PUE measurement
- Switched (on/off) options allow remote outlet management and equipment reboot with sequential delay features; avoid power interruption due to inrush current, equipment start up in desired sequence

- Highly secure access with admin, control and view-only accounts
- Intuitive Ethernet-based firmware with email alarm or SNMP trap features prevents downtime with early notification of power threshold breaches
- SNMP (MIB) enabled for compatibility with all leading DCIM packages
- Integrated environmental monitoring capabilities; monitor temperature, air flow, humidity and dew point via optional connected sensors
- Internal memory for up to two week of trending of critical parameters for clear understanding of power allocation and usage

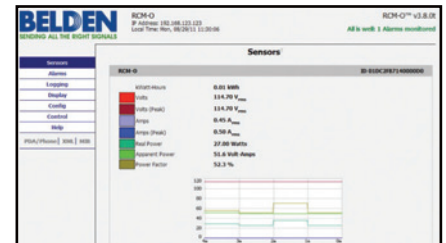

PDU Firmware, Trending Page



PDU Firmware, Alarm Setting Page



Intelligent PDU Communication and Environmental Monitoring Ports

Belden PDU Type	Local Display/ Monitoring	Intelligent-Remote Monitoring (3)				
		Current	Power Circuit Level	Environmental Port (4)	Power Outlet Level (5)	Outlet Switched (6)
Basic (B)	No	No	No	No	No	No
Local (L)	Yes	No	No	No	No	No
Current (C)	Yes (1)	Yes	No	No	No	No
Power (P)	Yes (2)	Yes	Yes	Yes	No	No
Power Outlet (O)	Yes (2)	Yes	Yes	Yes	Yes	No
Switched (S)	Yes (2)	Yes	Yes	Yes	Optional	Yes

Notes:

- (1) Local current/amp meter, monitoring at circuit level for multi-circuit PDU.
- (2) Local power meter provides Amps, Volts, Watts, Volt-Amps, kWh and Power Factor.
- (3) Remote functions (IP-based) accessible via web browser.
- (4) Remote IP-based environmental monitoring, (2) port per PDU. Requires external sensor, refer to accessories (p. 78) for selection.
- (5) Remote IP-based receptacle level monitoring, Amps, Volts, Watts, kWh.
- (6) Remote IP-based receptacle level switching (on/off) with configurable time delay.

Power, Cooling and Air Handling Relations

PDU Nameplate Current Rating (A)	Branch Circuit Rating (A)	Nameplate Volts (V)	Volts Actual Delivered (V)	Phase*	PDU Nominal Power Watts (W)	PDU De-Rated Power (W)	PDU De-Rated Power (kW)	PDU De-Rated Power (BTU/hr)	AC Tons** (BTU/12000)	Air Volume*** (120 CFM* kW)
12	15	125	120	1	1,800	1,440	1.4	4,916	0.41	168
16	20	125	120	1	2,400	1,920	1.9	6,555	0.55	228
24	30	125	120	1	3,600	2,880	2.9	9,832	0.82	348
16	20	250	208	1	4,160	3,328	3.3	11,362	0.95	396
24	30	250	208	1	6,240	4,992	5.0	17,043	1.42	600
35	50	250	208	1	10,400	7,280	7.3	24,854	2.07	876
48	60	250	208	1	12,480	9,984	10.0	34,085	2.84	1,200
16	20	230	230	1	4,600	3,680	3.7	12,564	1.05	444
24	30	230	230	1	6,900	5,520	5.5	18,845	1.57	660
48	60	230	230	1	13,800	11,040	11.0	37,691	3.14	1,320
16	20	120/208	208	3	7,197	5,757	5.8	19,656	1.64	696
24	30	120/208	208	3	10,795	8,636	8.6	29,484	2.46	1,032
35	50	120/208	208	3	17,992	12,594	12.6	42,997	3.58	14,712
48	60	120/208	208	3	21,616	17,293	17.3	58,968	4.91	2,076
80	100	120/208	208	3	36,027	28,821	28.8	98,279	8.19	3,456
100	125	120/208	208	3	45,033	36,027	36.0	122,849	10.24	4,320
120	150	120/208	208	3	54,040	43,232	43.2	147,419	12.28	5,184
16	20	230/400	230	3	13,856	11,085	11.0	37,691	3.14	1,320
24	30	230/400	230	3	20,785	16,628	16.6	56,563	4.71	1,992
*3-Phase power is calculated by multiplying single phase by the square root of 3 or 1.73.										
**Tons of air conditioning required to remove heat from associated IT load.										
***The volume of air that is typically required by the IT equipment for each kW of IT load can typically range from 80 to 140 CFM. 120 CFM was used for calculation.										



Single-Phase PDUs



Front View 9LF1-101001



Rear View 9LF1-101001



9LB2-301001

UL Listed Single-Phase PDUs

Type: B = Basic; L = Local Monitored

Belden Part #	Type	De-Rated Power (kW)	Amps (A)/ Volts (V)	Plug Type	Total Receptacle	Receptacle Type/Qty	Thermal Circuit Breaker	On-Off Switch	Surge Suppression	Monitoring-Local	Mounting (4)	Dimensions L x W x D (in.)
9BF1-061001	B	1.4	15/120	5-15P	6	5-15R/6	Yes	Yes	No	No	Rack - 19"	17 x 1.72 x 3.75
9BF1-061002	B	1.4	15/120	5-15P	6	5-15R/6	Yes	Yes	Yes	No	Rack - 19"	17 x 1.72 x 3.75
9BF1-081001	B	1.4	15/120	5-15P	8	5-15R/8	Yes	Yes	No	No	Vertical	24 x 1.61 x 1.61
9LF1-101001	L	1.4	15/120	5-15P	10	5-15R/10	Yes	Yes	No	Power	Rack - 19"	17 x 1.72 x 4.5
9BF1-141001	B	1.4	15/120	5-15P	14	5-15R/14	Yes	Yes	Yes	No	Vertical	47.5 x 1.61 x 1.61
9BG2-081001	B	1.9	20/120	L5-20P	8	5-20R/8	Yes	Yes	No	No	Vertical	24 x 1.61 x 1.61
9BG1-101001	B	1.9	20/120	5-20P	10	5-20R/10	Yes	Yes	Yes	No	Rack - 19"	17 x 1.72 x 3.75
9LG1-101001	B	1.9	20/120	5-20P	10	5-20R/10	Yes	No	No	Power	Rack - 19"	17 x 1.72 x 4.5
9BG1-141001	B	1.9	20/120	5-20P	14	5-20R/14	Yes	Yes	No	No	Vertical	47.5 x 1.61 x 1.61
9BG2-141001	B	1.9	20/120	L5-20P	14	5-20R/14	Yes	Yes	No	No	Vertical	47.5 x 1.61 x 1.61
9BG1-141002	B	1.9	20/120	L5-20P	14	5-20R/14	Yes	No	Yes	No	Vertical	47.5 x 1.61 x 1.61
9BG2-141002	B	1.9	20/120	L5-20P	14	5-20R/14	Yes	No	Yes	No	Vertical	47.5 x 1.61 x 1.61
9LH2-241001	L	2.8	30/120	L5-30P	24	5-20R/24	Magnetic	Breaker	No	Power	Vertical	66.25 x 2 x 2
9LB2-121001	L	5	30/208	L6-30P	12	C-13/12	Magnetic	Breaker	No	Power	Rack - 19"	17 x 1.72 x 6.5
9LB2-301001	L	5	30/208	L6-30P	30	C-13/24 + C-19/6	Magnetic	Breaker	No	Power	Vertical	66.25 x 2 x 2

- Notes:
- (1) Standard cord length is 10 ft. For other lengths, change dd digit in part # (ex: 9PB2-30dd01 would be 9PB2-300801 = 8 ft). Available in 2, 4, 6, 8, 10, 15, 20 ft.
 - (2) Standard cord exits from chassis face; top of chassis exit available on request.
 - (3) Standard PDU chassis color is black, custom color overlay available on request.



Front View 9PG2-101001



Rear View 9PG2-101001



9OB2-241001

UL Listed Single-Phase PDUs

Type: P = Remote Power Monitored; O = Outlet Monitored

Belden Part #	Type	De-Rated Power (kW)	Amps (A)/ Volts (V)	Plug Type	Total Receptacle	Receptacle Type/Qty	Thermal Circuit Breaker	On-Off Switch	Monitoring-Local/Remote	Environmental Monitoring	Mounting (4)	Dimensions L x W x D (in.)
9PG2-101001	P	1.9	20/120	5-20P	10	5-20R/10 + 0	Magnetic	No	Power/Aggregate	Yes - 2 Port	Rack - 19"	17 x 1.72 x 6.5
9PB2-301001	P	5	30/208	L6-30P	30	C-13/24 + C-19/6	Magnetic	Breaker	Power/Circuit Breaker	Yes - 2 Port	Vertical	66.25 x 2 x 2.25
9PB2-301002	P	5	30/208	L6-30P	30	C-13L/24 + C-19L/6	Magnetic	Breaker	Power/Circuit Breaker	Yes - 2 Port	Vertical	72 x 2 x 2.25
9PB2-421001	P	5	30/208	L6-30P	42	C-13/36 + C-19/6	Magnetic	Breaker	Power/Circuit Breaker	Yes - 2 Port	Vertical	70 x 2 x 2.25
9OB2-241001	O	5	30/208	L6-30P	24	C-13L/18 + C-19L/6	Magnetic	Breaker	Power/Circuit Breaker + Outlet	Yes - 2 Port	Vertical	72 x 2.25 x 2.25

- Notes:
- (1) Standard cord length is 10 ft. For other lengths, change dd digit in part # (ex: 9PB2-30dd01 would be 9PB2-300801 = 8 ft). Available in 2, 4, 6, 8, 10, 15, 20 ft.
 - (2) Standard cord exits from chassis face; top of chassis exit available on request.
 - (3) C-13L, L refers to receptacles with locking feature.
 - (4) Standard PDU chassis color is black, custom color overlay available on request.
 - (5) These PDUs have no Surge Suppression.

Faster.
Easier.
Better.



3-Phase PDUs



9LI2-301001



ZPB248-106IBBPS15

UL Listed 3-Phase PDUs

Type: B = Basic; L = Local Monitored

Belden Part #	Type	De-Rated Power (kW)	Amps (A) x Phases	Input Volts (V)/ Output Volts (V)	Plug Type	Total Receptacle	Receptacle Type/Qty(s)	Circuit Breaker (Amp/Qty)	Monitoring-Local/Remote	Mounting	Dimensions L x W x D (in.)
9LI2-301001	L	5.7	20 x 3 Ph.	120/208 WYE/208	L21-20P	30	C-13/24 + C-19/6	No	Amp (X,Y,Z)/No	Vertical	66.25 x 2 x 2 Dog House - No
9LJ2-301001	L	8.6	30 x 3 Ph.	120/208 WYE/208	L21-30P	30	C-13/24 + C-19/6	20/3D	Amp (X,Y,Z)/No	Vertical	66.25 x 2 x 2 Dog House - No
9BJ2-331001	B	8.6	30 x 3 Ph.	120/208 WYE/120 & 208	L21-30P	33	C-13/24 + C-19/3 + 5-20R/6	20/3D	Amp (X,Y,Z)/No	Vertical	66.25 x 2 x 2 Dog House - No
9LC2-301001	L	11	20 x 3 Ph.	230/400 WYE/230	L22-20P	30	C-13/24 + C-19/6	No	Amp (X,Y,Z)/No	Vertical	66.25 x 2 x 2 Dog House - No
9LC3-301001	L	11	20 x 3 Ph.	230/400 WYE/230	4P, 5W	30	C-13/24 + C-19/6	No	Amp (X,Y,Z)/No	Vertical	66.25 x 2 x 2 Dog House - No
9LD2-301001	L	16.6	30 x 3 Ph.	230/400 WYE/230	L22-30P	30	C-13/24 + C-19/6	20/3D	Amp (X,Y,Z)/No	Vertical	66.25 x 2 x 2 Dog House - Yes
9LD3-301001	L	16.6	30 x 3 Ph.	230/400 WYE/230	4P, 5W	30	C-13/24 + C-19/6	20/3D	Amp (X,Y,Z)/No	Vertical	66.25 x 2 x 2 Dog House - Yes
9BL3-121001	B	17.3	60 x 3 Ph.	208 Delta/208	3P, 4W	12	C-19/12 + 0	20/6	Breaker/No	Rack - 19"	17 x 3.4 x 9 Dog House - No
9BL3-241001	B	17.3	60 x 3 Ph.	208 Delta/208	3P, 4W	24	C-13/12 + C-19/12	20/6	Breaker/No	Vertical	66.25 x 2.3 x 3.45 Dog House - No

Notes:

- (1) Standard cord length is 10 ft. For other lengths, change dd digit in part # (ex: 9PB2-30dd01 would be 9PB2-300801 = 8 ft). Available in 2, 4, 6, 8, 10, 15, 20 ft.
- (2) Standard cord exits from chassis face; top of chassis exit available on request.
- (3) C-13L, L refers to receptacles with locking feature.
- (4) Ex: 20/3D, D refers to double pole breakers (20A in this case).
- (5) Standard PDU chassis color is black, custom color overlay available on request.
- (6) These PDUs have no Surge Suppression or On/Off Switch.
- (7) PDU "Dog House" hosts the circuit breaker and protrude from the PDU chassis by 1.44".

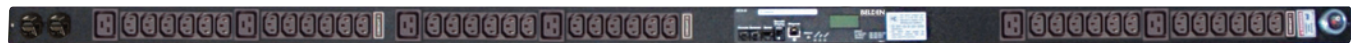

9PC2-441001



9OJ2-301001

UL Listed 3-Phase PDUs

Type: C = Remote Current Monitored; P = Power Monitored; O = Outlet Monitored

Belden Part #	Type	De-Rated Power (kW)	Amps (A) x Phases	Input Volts (V)/ Output Volts (V)	Plug Type	Total Receptacle	Receptacle Type/Qty(s)	Circuit Breaker (Amp/Qty) (4)	Monitoring-Local/Remote	Environ. Monitoring	Dimensions L x W x D (in.)
9PC2-441001	P	5.8	20 x 3 Ph.	120/208 WYE/208	L21-20P	44	C-13/36 + C-19/6 + 5-20R/2	No	Power/X, Y, Z	Yes - 2 Port	70 x 2 x 2.25 Dog House - No
9CJ2-301001	C	8.6	30 x 3 Ph.	120/208 WYE/208	L21-30P	30	C-13/24 + C-19/6	20/3D	Current/Current	No	66.25 x 2 x 2 Dog House - Yes
9OJ2-301001	O	8.6	30 x 3 Ph.	120/208 WYE/208	L21-30P	30	C-13L/24 + C-19L/6	20/3D	Power/X, Y, Z + Outlet	Yes - 2 Port	72 x 2.25 x 2.25 Dog House - Yes
9OC2-241001	O	11	20 x 3 Ph.	230/400 WYE/230	L22-20P	24	C-13L/18 + C-19L/6	No	Power/X, Y, Z + Outlet	Yes - 2 Port	66.25 x 2 x 2 Dog House - No
9OD3-241001	O	16.6	30 x 3 Ph.	230/400 WYE/230	4P, 5W	24	C-13L/18 + C-19L/6	20/6	Power/X, Y, Z + Outlet	Yes - 2 Port	72 x 2.25 x 2.25 Dog House - Yes
9PL3-301001	P	17.3	60 x 3 Ph.	208 Delta/208	4P, 4W	30	C-13/24 + C-19/6	20/6D	Power/X, Y, Z	Yes - 2 Port	72 x 2.3 x 3.45 Dog House - No

Notes:

- (1) Standard cord length is 10 ft. For other lengths, change dd digit in part # (ex: 9PB2-30dd01 would be 9PB2-300801 = 8 ft). Available in 2, 4, 6, 8, 10, 15, 20 ft.
- (2) Standard cord exits from chassis face; top of chassis exit available on request.
- (3) C-13L, L refers to receptacles with locking feature.
- (4) Ex: 20/3D, D refers to double pole breakers (20A in this case).
- (5) Standard PDU chassis color is black, custom color overlay available on request.
- (6) These PDUs have no Surge Suppression or On/Off Switch.
- (7) PDU "Dog House" hosts the circuit breaker and protrude from the PDU chassis by 1.44".
- (8) All these 3-Phase PDUs are vertically mounted.



Single- and 3-Phase PDUs



Front View 9SG1-081002



Rear View 9SG1-081002



9SJ2-241001 9SJ2-241002

UL Listed Single- and 3-Phase PDUs

Type: S = Remotely Switched

Belden Part #	Type	De-Rated Power (kW)	Amps (A) x Phases	Input Volts (V)/ Output Volts (V)	Plug Type	Total Receptacle	Receptacle Type/ Qty(s)	Circuit Breaker (Amp/Qty) (4)	Monitoring-Local/ Remote	Mounting (5)	Dimensions L x W x D (in.)
9SG1-081001	S	1.9	20	120/120	5-20P	8	5-20R/8	No	Power/Agg Power	Rack - 19"	17 x 1.72 x 8.5 Dog House - No
9SG1-081002	S	1.9 or 3.3	20	120 or 208/120 or 208	C-20	8	C-13L/8	No	Power/Agg + Outlet	Rack - 19"	17 x 1.72 x 8.5 Dog House - No
9SB2-241001	S	5	30	208/208	L6-30P	24	C-13L/20 + C-19L/4	20/2D	Power/Agg, Circuit, Outlet	Vertical	70 x 2.5 x 2.25 Dog House - Yes
9SJ2-241001	S	8.6	30 x 3 Ph.	120/208 WYE/208	L21-30P	24	C-13L/18 + C-19L/6	20/3D	Power/Agg, Circuit	Vertical	70 x 2.5 x 2.25 Dog House - Yes
9SJ2-241002	S	8.6	30 x 3 Ph.	120/208 WYE/208	L21-30P	24	C-13L/18 + C-19L/6	20/3D	Power/Agg, Circuit, Outlet	Vertical	70 x 2.5 x 2.25 Dog House - Yes
9SC3-241001	S	11	20 x 3 Ph.	230/400 WYE/230	3P, 4W	24	C-13L/21 + C-19L/3	No	Power/Agg, Circuit	Vertical	66.25 x 2.5 x 2.25 Dog House - No
9SC3-241002	S	11	20 x 3 Ph.	230/400 WYE/230	3P, 4W	24	C-13L/21 + C-19L/3	No	Power/Agg, Circuit, Outlet	Vertical	66.25 x 2.5 x 2.25 Dog House - No
9SC2-241001	S	11	20 x 3 Ph.	230/400 WYE/230	L22-20P	24	C-13L/21 + C-19L/3	No	Power/Agg, Circuit	Vertical	66.25 x 2.5 x 2.25 Dog House - No
9SC2-241002	S	11	20 x 3 Ph.	230/400 WYE/230	L22-20P	24	C-13L/21 + C-19L/3	No	Power/Agg, Circuit, Outlet	Vertical	66.25 x 2.5 x 2.25 Dog House - No
9SD3-241001	S	16.6	30 x 3 Ph.	230/400 WYE/230	4P, 5W	24	C-13L/21 + C-19L/3	20/6	Power/Agg, Circuit	Vertical	72 x 2.5 x 2.25 Dog House - No
9SD3-241002	S	16.6	30 x 3 Ph.	230/400 WYE/230	4P, 5W	24	C-13L/21 + C-19L/3	20/6	Power/Agg, Circuit, Outlet	Vertical	72 x 2.5 x 2.25 Dog House - No
9SD2-241001	S	16.6	30 x 3 Ph.	230/400 WYE/230	L22-30P	24	C-13L/21 + C-19L/3	20/6	Power/Agg, Circuit	Vertical	72 x 2.5 x 2.25 Dog House - No
9SD2-241002	S	16.6	30 x 3 Ph.	230/400 WYE/230	L22-30P	24	C-13L/21 + C-19L/3	20/6	Power/Agg, Circuit, Outlet	Vertical	72 x 2.5 x 2.25 Dog House - No
9SL3-241001	S	17.2	60 x 3 Ph.	208 Delta/208	3P, 4W	24	C-13L/18 + C-19L/6	20/6D	Power/Agg, Circuit	Vertical	66.25 x 4 x 3.45 Dog House - No
9SL3-241002	S	17.2	60 x 3 Ph.	208 Delta/208	3P, 4W	24	C-13L/18 + C-19L/6	20/6D	Power/Agg, Circuit, Outlet	Vertical	66.25 x 4 x 3.45 Dog House - No

Notes:

- (1) Standard cord length is 10 ft. For other lengths, change dd digit in part # (ex: 9PB2-30dd01 would be 9PB2-300801 = 8 ft). Available in 2, 4, 6, 8, 10, 15, 20 ft. 9SG1-081002 Power Cord is sold separately.
- (2) Standard cord exits from chassis face; top of chassis exit available on request.
- (3) C-13L, L refers to receptacles with locking feature.
- (4) Ex: 20/3D, D refers to double pole breakers (20A in this case).
- (5) Standard PDU chassis color is black, custom color overlay available on request.
- (6) These PDUs have no On/Off Switch or Surge Suppression.
- (7) PDU "Dog House" hosts the circuit breaker and protrude from the PDU chassis by 1.44".
- (8) All these Single- and 3-Phase PDUs have a Switched Outlet and a 2-port Environmental Monitor.

Faster.
Easier.
Better.



PDU Accessories — Mounting, Cord Management and Cord Set



Description	Belden Part Number
Tool-Less PDU Mounting Panel (for XHM and XHS Style Cabinets)	
Lacing-PDU Mounting Panel, 3.5"W, 42RU, Black	XVMP014201
Lacing-PDU Mounting Panel, 3.5"W, 45RU, Black	XVMP014501
Lacing-PDU Mounting Panel, 3.5"W, 48RU, Black	XVMP014801
Lacing-PDU Mounting Panel, 7"W, 42RU, Black	XVMP024201
Lacing-PDU Mounting Panel, 7"W, 45RU, Black	XVMP024501
Lacing-PDU Mounting Panel, 7"W, 48RU, Black	XVMP024801
Lacing-PDU Mounting Panel, 3.5"W, 42RU, White	XVMP014202
Lacing-PDU Mounting Panel, 3.5"W, 45RU, White	XVMP014502
Lacing-PDU Mounting Panel, 3.5"W, 48RU, White	XVMP014802
Lacing-PDU Mounting Panel, 7"W, 42RU, White	XVMP024202
Lacing-PDU Mounting Panel, 7"W, 45RU, White	XVMP024502
Lacing-PDU Mounting Panel, 7"W, 48RU, White	XVMP024802
Tool-Less PDU Mounting Panel (for XN Style Cabinets)	
PDU Mounting Bracket Double, Post Mounting 2 PDU Side-by-Side Facing Into Cabinet	XNPM01
PDU Mounting Bracket Single, Rear Facing Pair	XNPM02
PDU Mounting Bracket Rear Facing Pair Between Frames	XNPM03
PDU Mounting Bracket Rear Facing Pair Between Frames with Extension	XNPM04
Vertical Manager Panel, 42RU X 7.0"W, Black	XNVLP42901
Vertical Manager Panel, 45RU X 7.0"W, Black	XNVLP45901
Vertical Manager Panel, 48RU X 7.0"W, Black	XNVLP48901
Vertical Manager Panel, 42RU X 7.0"W, CO White	XNVLP42902
Vertical Manager Panel, 45RU X 7.0"W, CO White	XNVLP45902
Vertical Manager Panel, 48RU X 7.0"W, CO White	XNVLP48902
Tool-Less PDU Mounting Panel (for XSS Seismic Cabinets)	
Cable PDU Manager Rear Panel, 44RU, Rear, Black	XSN44VRPM101
Cable PDU Manager Rear Panel, 44RU, Rear, with 6 Rings, Black	XSN44VRPM201
Cable PDU Manager Rear Panel, 44RU, Rear, CO White	XSN44VRPM102
Cable PDU Manager Rear Panel, 44RU, Rear, with 6 Rings, CO White	XSN44VRPM202
Tool-Less PDU Mounting Panel (for XSN Seismic Cabinets)	
Cable PDU Manager Rear Panel, 44RU, Rear, Black	XSN44VRPM101
Cable PDU Manager Rear Panel, 44RU, Rear, with 6 Rings, Black	XSN44VRPM201
Cable PDU Manager Rear Panel, 44RU, Rear, CO White	XSN44VRPM102
Cable PDU Manager Rear Panel, 44RU, Rear, with 6 Rings, CO White	XSN44VRPM202
Power Cord Management	
Cable Management Ring Plastic (Qty = 5) 3" x 1.5" Reversible	XMR01
Cable Management Ring Kit (Qty = 5) 2.5"W x 3"D	XMR03
Slack Management Spool Kit (includes 2 spools)	XSK020
Quick Mount Base (Qty=10) with Fastener, for 1/4" Holes	XCTM
Velcro Cable Ties, 25 per Roll, 8" L x 0.5"W	AX100783
Velcro Cable Ties, 25 per Roll, 12" L x 0.5"W	AX100784
Cord Set* (C13/C19, C19/C20 - UL - cUL Listed)	
C13 to C14 Non-Locking Cord Set - Y" Long — Black	CSC13C14yyBK
C13 to C14 Non-Locking - 36" Long — Black	CSC13C1436BK
C13 to C14 Non-Locking - 48" Long — Black	CSC13C1448BK
C19 to C20 Non-Locking Cord Set - Y" Long — Black	CSC19C20yyBK
C19 to C20 Non-Locking - 36" Long — Black	CSC19C2036BK
C19 to C20 Non-Locking - 48" Long — Black	CSC19C2048BK
C13 Locking to C14 - 20" Long — Blue	CSLC13C1420BL
C13 Locking to C14 - 20" Long — Orange	CSLC13C1420OR
C19 Locking to C20 - 20" Long — Blue	CSLC19C2020BL
C19 Locking to C20 - 20" Long — Orange	CSLC19C2020OR
C13 Locking to C14 - 39" Long — Blue	CSLC13C1439BL
C13 Locking to C14 - 39" Long — Orange	CSLC13C1439OR
C19 Locking to C20 - 39" Long — Blue	CSLC19C2039BL
C19 Locking to C20 - 39" Long — Orange	CSLC19C2039OR

Notes: yy = 12, 24, 36 ... 96 = cord length 12 to 96 inches; 12 inch increments.

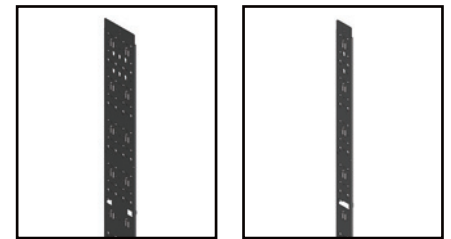

7" Lacing-PDU mounting panel

3.5" Lacing-PDU mounting panel

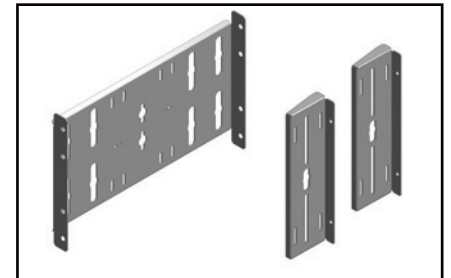

Mounting Brackets



Cable Management Ring (Plastic)

Quick Mount Base



Locking Cord Set*

*Built within the plug housing on the female end (C13/C19) of the cord, the patented integrated locking mechanism is protected against vibration and external elements that can easily dislodge other plug securing solutions, like external locking clips and guides. This self-contained locking mechanism engages with any standard IEC male connector (C14/C20). The cord locking feature is only available at the device-end of the cord sets. A power strip with locking receptacles must be available to secure these cords to the PDU.

Power Distribution Unit Configuration Guide

Please select the desired configuration and specifications and submit to Belden.

Power Availability _____ Phone _____ E-mail _____
 Quantity Required _____ Target Price _____ Project Timeline _____
 First Unit Required by Date _____ Comparable Competitive Unit Brand/Model# _____

Electrical Configuration

Power Input			
Quantity**	Plug Type	Input AMPS	Input VOLTS
	5-15P	15	125
	L5-15P	15	125
	5-20P	20	125
	L5-20P	20	125
	6-20P	20	250
	L6-20P	20	250
	L14-20P	20	125/250
	L21-20P	20 x 3~	120/208 WYE
	L5-30P	30	125
	L6-30P	30	250
	L14-30P	30	125/250
	L15-30P	30 x 3~	250 Delta
	L21-30P	30 x 3~	120/208 WYE
	IEC C-20 Inlet (No Cord)	20/16*	125 or 250
	IEC Pin & Sleeve 2 Pole/3 Wire	20/16*	250/230*
	IEC Pin & Sleeve 3 Pole/4 Wire	20	250 3~
	IEC Pin & Sleeve 2 Pole/3 Wire	30/32*	250/230*
	IEC Pin & Sleeve 3 Pole/4 Wire	30	250 3~
	IEC Pin & Sleeve 2 Pole/3 Wire	60/63*	250/230*
	IEC Pin & Sleeve 3 Pole/4 Wire	60	250 3~
Cord Length			

Power Input			
Quantity	Receptacle Type	AMPS	VOLTS
	5-15R Duplex	15	125
	5-15R Individual	15	125
	L5-15R Duplex	15	125
	5-20R Duplex	20	125
	5-20R Individual	20	125
	L5-20R	20	125
	6-20R Duplex	20	250
	L6-20R	20	250
	L5-30R	30	125
	L6-30R	30	250
	IEC C-13	15/10*	125 or 250
	IEC C-19	20/16*	125 or 250
	Other - Please Specify		

Physical Configuration			
Dimensional Limits		Mounting Orientation	
	Length		Horizontal
	Width		Vertical
	Height		

Hardware Options	
Quantity**	
	6" Wire Tails with Removable Plate
	Flexible Conduit
	Terminal Block

Power Switch	Surge Suppression
No	No
Yes	Yes
Yes - with Cover	

Monitoring	
Current Local	Current Remote
No	No
Yes - Current (Amps) Only	Yes - Circuit Level
Yes - Scrolling Display (Volts, Amps, Watts, Power Factor)	Yes - Outlet Level

Environmental	Remote Switching
No	No
Yes	Yes

Circuit Breakers	Isolated Ground
No (required by NEC in some units)	No
Yes	Yes

3rd Party Testing - Compliance	
UL® Listed	UR - UL® Recognized
FCC Part 15 Class A	CE®
None Required	Other - Please Specify

Additional Information

Notes:
 *Rating for CE Products
 **Quantity = # of Circuits

Faster.
Easier.
Better.



Plug and Receptacle Configuration Chart

NEMA Plugs and Receptacles

AMP	VOLTS	Straight-Blade Plug	Straight-Blade Receptacle	AMP	VOLTS	Straight-Blade Plug	Straight-Blade Receptacle
15	125	5-15P	5-15R	20	250	6-20P	6-20R
20	125	5-20P	5-20R				
AMP	VOLTS	Twist-Lock Plug	Twist-Lock Receptacle	AMP	VOLTS	Twist-Lock Plug	Twist-Lock Receptacle
15	125	L5-15P	L5-15R	20	120/208 x 3- WYE	L21-20P	L21-20R
20	125	L5-20P	L5-20R	20	230/400 x 3- WYE	L22-20P	L22-20R
30	125	L5-30P	L5-30R	30	120/208 x 3- WYE	L21-30P	L21-30R
20	250	L6-20P	L6-20R	30	230/400 x 3- WYE	L22-30P	L22-30R
30	250	L6-30P	L6-30R	30	250 x 3- Delta	L15-30P	L15-30R
20	125/250	L14-20P	L14-20R	AMP	VOLTS	California Style	
30	125/250	L14-30P	L14-30R	50	250 x 3- Delta	3P, 4W	3P, 4W

IEC Plugs and Receptacles

AMP	VOLTS	Power Inlet	Power Receptacle	AMP	VOLTS	Power Inlet	Power Receptacle
15/10*	125 or 250	C-14	C-13	20/16*	125 or 250	C-20	C-19
AMP	VOLTS	Pin & Sleeve		AMP	VOLTS	Pin & Sleeve	
20/16*	250/230*	2P, 3W	2P, 3W	60/63*	250/230*	2P, 3W	2P, 3W
20	250	3P, 4W	3P, 4W	60	250	3P, 4W	3P, 4W
30/32*	250/230	2P, 3W	2P, 3W	20/16*	230/400* x 3- WYE	4P, 5W	4P, 5W
30	250	3P, 4W	3P, 4W	30/32*	230/400* x 3- WYE	4P, 5W	4P, 5W

*Rating for CE Products

What is 3-Phase Delta?

3-Phase Delta from 208V Source

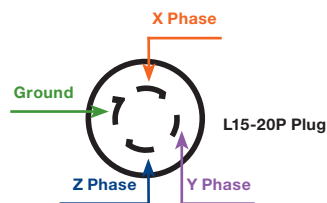

A 3-Phase Delta is a 4-wire configuration consisting of 3-Phase conductors (X, Y and Z) and a Ground. Without the neutral present, only phase-to-phase wiring is possible. The potential between any 2-Phase conductors is typically 208V.

What is 3-Phase WYE?

3-Phase Delta from 120/208V Source

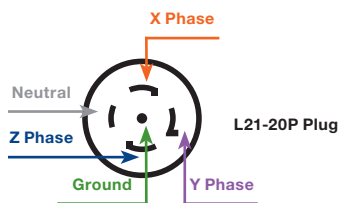

A 3-Phase Delta 120/208V WYE is a 5-wire configuration consisting of 3-Phase conductors (X, Y and Z), Neutral and Ground. The potential between any 2-Phase conductors is 208V. The potential between any phase and neutral is 120V. This configuration can be wired to provide 120V, 208V or a combination of both voltages within one PDU.

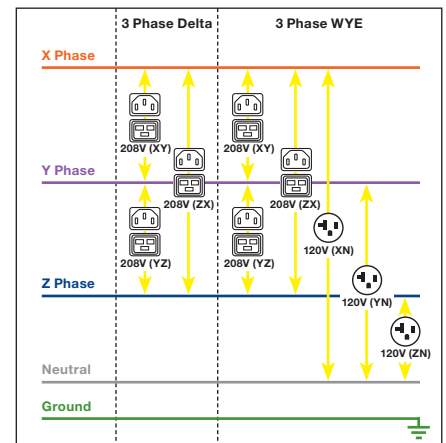



Environmental Monitors and Sensors



9318-0500



9318-0550



9318-0560



9318-0570

Applications

- Belden climate monitors and sensors allow precise monitoring/alarming of key environmental parameters for improved equipment availability in mission critical applications (Data Center, networking closet, remote locations)
- Built-in intuitive web interface for remote access via Ethernet browser
- Built-in and external sensor options (temperature, humidity, air flow, water detection, door position, smoke)
- SNMP-enabled for compatibility with leading DCIM package
- Recognize IP-based camera for space viewing
- Set alarm threshold, can be sent to up to five e-mail addresses
- Allows viewing of data graphs and analysis of historical logs
- Power supply included
- UL and cUL listed



9318-0513 Temperature Display with Thermocouple



9318-0503 Temp/Air Flow/Humidity Remote Sensor



9318-0506 Remote PDU Display



DLINKS Web Camera Kit

Description	Belden Part Number
Other Accessories	
Environmental Monitors	
Compact Self-Contained Environmental Monitor (5.25"Lx1.75"Hx1.5"W); Provides Web-Based Remote Surveillance with On-Board Temperature and Humidity/Dew Point Sensors. Has Input Capacity for Two External Sensors	9318-0500
Rack Mount 1RU Environmental Monitor. Provides Web-Based Remote Surveillance for up to (16) Digital Sensors and (3) Analog Sensors. This Unit Does Not Feature Internal Sensors	9318-0550
Rack Mount 1RU Environmental Monitor. Provides Web-Based Remote Surveillance of Temperature, Relative Humidity, Dew Point, Airflow, Light, Sound. Up to (5) Additional Digital Sensors Can Be Connected to the Unit. Comes Equipped with an LCD Display with Scrolling Measurements and a Built-In Audible Alarm	9318-0560
Rack Mount 1RU Environmental Monitor. Provides Web-Based Remote Surveillance of Temperature and any Additional Sensors Connected to the Unit. Comes Equipped with (4) Digital and (6) Analog Sensor Ports, an LCD Display with Scrolling Measurements, Built-In Audible Alarm and (3) Relay Output Ports	9318-0570
Environmental Monitors Accessories	
19" Rack Mount 16-Way Splitter, 1RU for RJ12 Sensors	9318-0510
Remote PDU Display, RJ12 Connection	9318-0506
Sensors (compatible with environmental monitors and intellignet PDU)	
Remote Temperature Sensor with 12 Ft. Wire	9318-0501
Remote Temperature Sensor with 20 Ft. Wire	9318-0510
Remote Temperature Sensor with 50 Ft. Wire	9318-0511
Remote Temperature/Air Flow/Humidity and Dew Point Sensor with 12 Ft. Wire	9318-0503
Remote Temperature/Air Flow/Humidity and Dew Point Sensor with 20 Ft. Wire	9318-0515
Remote Temperature/Air Flow/Humidity and Dew Point Sensor with 50 Ft. Wire	9318-0516
Remote Door Position Analog Sensor	9318-0504
Remote Water Detection Analog Sensor	9318-0505
DLINKS Web Camera Kit	9318-0509
Temperature Displays (local monitoring only)	
19" Rack Mount Temperature Display with Thermocouple; 1RU Blanking Panel Type	9318-0512
Temperature Display with Thermocouple; 1.72"H x 3.8"W x 1.1"D	9318-0513

Faster.
Easier.
Better.



Warranty and Shipping Policy

Warranty

Limited Warranty

Belden warrants that, for a period of one (1) year following the date of delivery to the original customer, the products it offers for sale in the catalog are free from defects in material and workmanship. The foregoing warranty is subject to the terms, limitations and conditions set forth below.

Liability

Belden's sole liability under this warranty will be to repair or replace, at its discretion, products that do not meet the specifications and descriptions provided in the catalog or purchase order due to defects in material and workmanship. Under no circumstances shall Belden be liable for any consequential or special damages for breach of this warranty. Belden's total liability under this warranty shall be limited to the price actually paid by the customer for the product(s) covered. Except as specifically set forth above, Belden expressly disclaims any other representation or warranties of any kind, expressed or implied, arising by law or custom, with respect to products set forth in the catalog or otherwise sold by Belden, including without limitation, warranties or merchantability, fitness for a particular purpose, non-infringement or any other matter.

Conditions of Warranty

This warranty applies only to standard products set forth in the catalog. Custom products are covered by warranties stated in the Terms and Conditions of Belden's quotation at the time of the order.

Repairs or Adjustments

Belden, at its discretion, will make any repairs or adjustments to any products that are due to defects and/or workmanship. This warranty does not extend to any items that upon inspection by Belden are deemed to have been misused, neglected, improperly treated, improperly installed, or used in violation of instructions or specifications approved by Belden, or otherwise handled, installed, shipped or used in violation of industry standards for metal fabrication and solid state electronic equipment.

Powerstrip Warranty

If a BELDEN power strip product becomes defective during the warranty period listed below, BELDEN will elect to either repair or replace the unit free of charge.

Basic Power Strips – Three Years

Metered, Monitored and Managed Power Strips – Three Years
Environmental Monitoring Units – Three Years

This warranty does not include damage to the product resulting from accident or misuse, including exposure to water or any other corrosive material. This warranty excludes damage to equipment if surge or spike reaches that equipment through an unprotected source connected to it (i.e., printer, modem, phone line, etc.). It shall not apply to any product, which has been connected, installed, used or otherwise adjusted other than in accordance with written instructions furnished by BELDEN.

WARRANTY WILL BE VOIDED IF THE UNITS ARE OPENED, MODIFIED OR ALTERED DURING THE WARRANTY PERIOD.

Containment and Cooling Warranty

BELDEN warrants Containment and Cooling products for a period of one (1) year following the date of delivery. If the BELDEN product becomes defective during the one (1) year warranty period, BELDEN will elect to either repair or replace the unit free of charge. This warranty does not include damage to the product resulting from accident or misuse, including exposure to water or any other corrosive material.

WARRANTY WILL BE VOIDED IF THE UNITS ARE OPENED, MODIFIED OR ALTERED DURING THE WARRANTY PERIOD.

Shipping Policy

Freight Handling Charges

Third-Party Billing – Customer will specify carrier. Freight will be third-party billed other than to Belden or the customer.

The customer will supply a third-party account number or third-party billing address.

Freight Collect – Customer to specify carrier. Either a freight account number is provided or freight charges will be paid at destination upon delivery.

Prepaid and Add – Belden will specify carrier which has contractual agreements with select carriers.

All freight charges that appear on initial product invoice will be paid by the customer, and will not require any additional freight documentation. Belden's billing cycle will only indicate on the invoice a freight charge from dock to dock. Any accessorial charges (e.g., lift gate, union driver) will be billed on an additional invoice other than the initial billing that will show the accessorial charges.

Shipping Policy

Belden will provide estimated freight charges and will not be liable for charges due to problems that may occur in transit or upon delivery or not known at the time of the initial quote (accessorial charges). All shipments leaving Belden are FOB origin.

Inside Delivery – A carrier driver will make an inside delivery if an adequate loading dock is available to roll off freight to a trailer level dock. The driver will be equipped to move the freight via hand truck or pallet jack and must be able to get to the inside destination without any problem of obstacles that would cause delays. The customer must supply a freight elevator if delivery requires it. This action may result in additional freight charges.

Lift Gate Service – Usually a lift gate is needed when a loading dock is not available. The freight is lowered to ground level and delivered to the customer's door "only." Not all trailers are equipped with a lift gate and most carrier terminals have a

limited number of lift gate trailers. This may cause a delay in shipment. This procedure may require an additional fee.

Notification – To coordinate delivery between the customer and the carrier, the customer must supply a phone number and contact person. This procedure may require an additional fee.

Re-Consignment – Once freight has left the Belden dock, the delivery destination address will be scheduled in the carrier dispatch system. A change of destination address is possible, depending upon the timing of delivery. This action may result in additional freight charges.

Redelivery – When a delivery is refused by a customer for any reason, other than the fault of the carrier, the freight will be returned to the carrier's dock. A redelivery charge will apply.

Damages

All damages must be reported to Belden within three (3) working days upon delivery. Failure to report any damages will release Belden from any and all claims. It is the responsibility of the customer's receiving personnel to check all shipping cartons for discrepancies (e.g., dents, punctures). All discrepancies to the shipping container should be noted on the carrier's paperwork and documented. If, after opening the container, it is found that there is damage to the product, the carton is to be examined to determine that the damage was due to shipping.

Failure to examine cartons at delivery, and signing the carrier's paperwork, releases the carrier and Belden from any and all freight claims.

Third-party billing customers will handle any and all freight claim damage with the carrier and are responsible for all freight charges.

Packaging

BELDEN cabinets are packaged in cardboard protective corner posts and protective plastic cover. The cabinets are then secured to a skid by banding prior to shipment.

Less than truck load shipments (LTL) might require additional packaging due to multiple handling locations. Belden provides full protective packaging (i.e. 3" honeycomb cardboard corner posts, honeycomb top cardboard cover, cardboard wrap, shock-watch drop spot indicator) for an additional fee to accommodate LTL shipments with special needs. Please contact your customer service or sales rep to discuss the packaging options.

Return Policy for Repair, Replacement, Modification or Credit

Prior approval must be obtained for any products being returned. Upon approval an RMA number will be assigned to the items being returned. This RMA number MUST appear on all shipping documents and on the outside of each carton. Failure to include the RMA number on the carton will result in the refusal of delivery and return to the customer, freight collect.

All products returned for reasons other than repair or replacement are subject to a 15% restocking fee and must be shipped prepaid. In addition to the 15% restocking fee, the customer is responsible for properly packaging and returning the product in reusable condition. If not, additional charges may be added to the restocking fee. If a customer holds a product for more than ten (10) days, a return for credit will be voided.

Any or all special customized products can only be returned for modifications or repair of damages.

All products being returned shall be prepaid (unless they are being returned due to defect or damage), packaged in good condition and shipped to:

Belden
2001 North Main Street
Washington, PA 15301

Part Number Index

Part No.	Page	Part No.	Page	Part No.	Page	Part No.	Page	Part No.	Page
9BF1-061001	74	8815-0210	70	9510-1901	67	BHTD196	47	HSTBK102	19
9BF1-061002	41, 74	8815-0211	70	9511-1902	67	BHTL196	47	HSTBK201	19
9BF1-081001	74	8815-0212	70	9511-1902-01	67	BHTT196	47	HSTBK202	19
9BF1-141001	74	8815-0221	70	9511-1903-01	67	BHTTH196	47	HSTBK301	19
9BG1-101001	41, 74	8815-0222	70	9511-1904-01	67	BHVH003	47	HSTBK302	19
9BG1-141001	74	8815-0223	70	9512-1901	47, 67	BHVH006	47	HVGB0142	21
9BG1-141002	74	8815-0224	70	9512-1902-FR	67	BHVH010	47	HVGB0145	21
9BG2-081001	74	8815-0225	70	9512-1902N	47, 67	BHVH012	47	HVGB0148	21
9BG2-301001	74	8815-0226	70	9512-1903	61, 64	BHVHH03	47	VCMFDR4X4	47
9BG2-141002	74	8815-0227	70	9714-0190	69	BHVHH06	47	X1SN-C1001	28
9BJ2-331001	75	8815-0228	70	9910-0100-01/-02	68	BHVHH10	47	X1SN-C1002	28
9BL3-121001	75	8815-0240	70	9910-0100PL-01/-02	68	BHVHH12	47	X1SN-C70101001	28
9BL3-241001	75	8815-0241	70	9911-0200-01/-02	68	BHVHLO3	47	X1SN-C70101002	28
9CJ2-301001	75	8815-0242	70	9911-0200PL-01/-02	68	BHVHLO6	47	X1SS-C1001	28
9LB2-121001	74	8815-0243	70	9911-0201-01	68	BHVHL10	47	X1SS-C1002	28
9LB2-301001	74	8815-0244	70	9912-0300-01/-02	68	BHVHL12	47	X2SN-C65091001	28
9LC2-301001	75	8815-0245	70	9913-0400-01/-02	68	BHVL003	47	X2SN-C65091002	28
9LC3-301001	75	8815-0280	70	9914-0800-01/02	68	BHVL006	47	X2SN-C65091004	28
9LD2-301001	75	8815-0282	70	20128-KIT	69	BHVL010	47	X2SN-C65091005	28
9LD3-301001	75	8815-0283	70	AX100783	21, 69, 77	BHVL012	47	X2SN-C70181001	28
9LF1-101001	74	8815-0284	70	AX100784	21, 69, 77	BSP-11U-6(x)	42	X2SN-C70181002	28
9LG1-101001	74	8910-0100	21, 69	AX102516	69	BSP-11U-12(x)	42	X2SS-C1001	28
9LH2-241001	74	8911-0100	69	AX102517	69	BSP-22U-6(x)	42	X2SS-C1002	28
9LI2-301001	75	8913-0100	69	AX105366	21	BSP-22U-12(x)	42	X3M45-1-100000	46
9LJ2-301001	75	8913-0220	69	AX105367	21	BSP-44U-6(x)	42	X4N45-C6509101	23
9OB2-241001	74	8913-0320	69	BHBC03X	47	BSP-ADPLATE*	42	X4N45-C6509102	23
9OC2-241001	75	8914-0100	69	BHBC06X	47	BSP-CBRKT	42	X4N45-C6509103	23
9OD3-241001	75	8915-0100	69	BHBC10X	47	BSP-D44U-6(x)	42	X4N45-C6509104	23
9OJ2-301001	75	8915-0220	69	BHBC12X	47	BSP-LOCK-C1	42	X4N45-C7009101	23
9PB2-301001	74	8915-0320	69	BHDB03X	47	CSC13C14yyBK	77	X4N45-C7009102	23
9PB2-301002	74	8917-0100	69	BHDB06X	47	CSC13C1436BK	77	X4N45-C7010101	23
9PB2-421001	74	8917-0125	41	BHDB10X	47	CSC13C1448BK	77	X4N45-C7010102	23
9PC2-441001	75	8917-0220	69	BHDB12X	47	CSC19C20yyBK	77	X4N45-C7018101	23
9PG2-101001	74	8917-0320	69	BHDK03X	47	CSC19C2036BK	77	X4N45-C7018102	23
9PL3-301001	75	9010-1924	66	BHDK06X	47	CSC19C2048BK	77	XBK01	26, 69
9SB2-241001	76	9010-1930	66	BHDK10X	47	CSLC13C1420BL	77	XBS-11-0001	69
9SC2-241001	76	9010-1936	66	BHDK12X	47	CSLC13C1420OR	77	XBS-18-0001	69
9SC2-241002	76	9011-1912	66	BHFB11U	47	CSLC13C1439BL	77	XBS-18-0002	69
9SC3-241001	76	9011-1918	66	BHFS11U	47	CSLC13C1439OR	77	XCK01	21, 26
9SC3-241002	76	9011-1918-16	66	BHGL03X	47	CSLC19C2020BL	77	XCK02	21, 26
9SD2-241001	76	9012-1918	66	BHGL06X	47	CSLC19C2020OR	77	XCTM	26, 77
9SD2-241002	76	9012-1918-16	66	BHGL10X	47	CSLC19C2039BL	77	XCTV12	58, 61, 64
9SD3-241001	76	9013-1924	66	BHGL12X	47	CSLC19C2039OR	77	XCTV18	58, 61, 64
9SD3-241002	76	9015-1909	66	BHGR03X	47	FFZH00BB	21	XCTV24	58, 61, 64
9SG1-081001	76	9318-0500	80	BHGR06X	47	FFZH06KC	21	XDR8419-310	46
9SG1-081002	76	9318-0501	80	BHGR10X	47	FFZH08KC	21	XDR8419-310N	46
9SJ2-241001	76	9318-0503	80	BHGR12X	47	HCBS-1932-1.5-01	67	XDR8419-310N1M	46
9SJ2-241002	76	9318-0504	80	BHH191UC	67	HCBS-1932-2.5-01	67	XDR8419-310N2M	46
9SL3-241001	76	9318-0505	80	BHH191UR	47, 67	HCC001-B	36	XDR8419-310W	46
9SL3-241002	76	9318-0506	80	BHH192UC	67	HCC001-W	36	XDR8419-312	46
8429-NFD-3	38	9318-0509	80	BHH192UR	47, 67	HCCBP-B	36	XDR8419-312N	46
8429-NGD-3	38	9318-0510	80	BHH193UC	67	HCCBP-W	36	XDR8419-312N1M	46
8429-NKD-3	38	9318-0511	80	BHH193UR	47, 67	HCDBP-B	36	XDR8419-312N2M	46
8429-NSD-3	38	9318-0512	80	BHH194UC	67	HCDBP-W	36	XDR8419-312W	46
8440-01-NSP-3	38	9318-0513	80	BHH194UR	47, 67	HCFD10	36	XDR8419-3102836	46
8440-02-NSP-3	38	9318-0515	80	BHPF100	47	HCFD30	36	XDR8419-3122836	46
8815-0100	70	9318-0516	80	BHRR194	46	HCH001	36	XDRS8419-610	46
8815-0101	70	9318-0550	80	BHRR6194	46	HCP001	36	XDRS8419-61028	46
8815-0102	70	9318-0560	80	BHSM100	47	HCP002	36	XDRS8419-61032	46
8815-0103	70	9318-0570	80	BHSP020	47	HSRSBK01	19	XFPWB1U101/02	68
8815-0104	70	9420-1905	68	BHSP030	21, 26, 47	HSRSBK02	19	XFPWB2U101/02	68
8815-0200	70	9420-1906	68		21, 26	HSTBK101	19	XFPWB3U101/02	68

Part Number Index

Faster.
Easier.
Better.



Part No.	Page	Part No.	Page	Part No.	Page	Part No.	Page	Part No.	Page
XFPWB4U101/02	68	XMR01	21, 26, 77	XNVLP45901	77	XSSFS4401	29	XWB-2U	48
XH1S45-C1000	17	XMR02	21, 26	XNVLP45902	77	XSSVMP014401	29	XWB-4U	48
XH1S45-C2000	17	XMR03	21, 26, 77	XNVLP48901	77	XSSVMP014402	29	XWB-6U	48
XH2S45-C1000	17	XN4530ADS0101	26	XNVLP48902	77	XSSVMP024401	29	XWM-2109-GD	41
XH2S45-C1001	17	XN4530ADS0102	26	XPE-S0001	48	XSSVMP024402	29	XWM-2109-SD	41
XH2S45-C2000	17	XN4530ADS0301	26	XSFbk01	69	XSW-0100	49	XWM-2312-GD	41
XH2S45-C2001	17	XN4530ADS0302	26	XSK020	77	XSW-0200	49	XWM-2312-SD	41
XLK01	21, 26	XN4530ADS0401	26	XSN44VRPM101	30, 77	XSW-8419	49	XWM-2320-GD	41
XMEBK01	61, 64, 69	XN4530ADS0402	26	XSN44VRPM102	30, 77	XTCM01	21	XWM-2320-SD	41
XMEEG01	61	XNFS42	26	XSN44VRPM201	30, 77	XVMP014201	77	XWM-9312-1600	41
XMEGK01	61, 64	XNFS45	26	XSN44VRPM202	30, 77	XVMP014202	77	XWMLP9	41
XMELM	61, 64	XNFS48	26	XSNTCT3001	30	XVMP014501	77	XWMLP12	41
XMERSB	61, 64	XNM-0100	69	XSNTCT3002	30	XVMP014502	77	XWMLP20	41
XMFBK01	58, 69	XNPM01	26, 77	XSNTCT4001	30	XVMP014801	77	XWR-1219	48
XMFBK02	58, 69	XNPM02	26, 77	XSNTCT4002	30	XVMP014802	77	XWR-3619-18	48
XMFBK03	58	XNPM03	26, 77	XSNVMP440301	30	XVMP024201	77	XWR-3619-18HD	48
XMFACTM	55, 58, 61, 64, 69	XNPM04	26, 77	XSNVMP440302	30	XVMP024202	77	XWR-4819-18	48
XMFEK01	58	XNSKB01	26	XSS4424RSK01	29	XVMP024501	77	XWR-4819-18HD	48
XMFEK02	58	XNSKB02	26	XSS4424RSK02	29	XVMP024502	77	XZUK01	21
XMFS01	29	XNVLP42901	77	XSS4430RSK01	29	XVMP024801	77	XZUK02	21
XMFSB	58	XNVLP42902	77	XSS4430RSK02	29	XVMP024802	77		

Part Number Index

Belden Rack and Cabinet Manufacturing

State-of-the-Art Manufacturing and Assembly Operation

Lean Manufacturing

Belden's lean manufacturing philosophy is exemplified in its manufacturing plant, where infrastructure solutions, including racks, cabinets, heat containment and rack power distribution units, are produced. The plant is structured for cell-based manufacturing, where automated machines, such as the CNC punch press, CNC laser-punch combination machine and CNC CO₂ lasers, work seamlessly with semi-automated metal-bending machines and assembly operations.



Packaging and Shipping

In order to provide our customers with high-performance cabinet systems and just-in-time delivery, the factory process flow is based on a value stream map, with raw materials received at a receiving dock (close to fabricating cells) and finished goods shipped from a shipping dock (close to the packaging cell). All cabinets are shipped with unique serial number tags, enabling full traceability.



Environmentally Friendly Powder Coating

Belden's powder-coating process involves industry leading five-stage wash and pre-treatment steps, ensuring a lasting and durable finish. Each cabinet is baked in compliance with ASTM standards to prevent paint from scaling or chipping, thus ensuring rust-proof cabinets. The entire process is environmentally friendly, with complete conformance to both state and federal "Clean Air Act" guidelines.



Quality Inspection

The cell-based assembly process includes stringent quality checks at each location within the cell, which are tracked in an assembly check list by each associate assembling an cabinet system. Throughout this manufacturing process, the external quality, measured in defects per million, is less than 100. Lean daily management (LDM) and continuous improvement processes drive manufacturing and design philosophy at Belden to ensure each customer's quality and delivery expectations are met in a safety conscious work environment.



Fabrication

Precision CO₂ lasers with automated loading and unloading capabilities are at the heart of our sheet metal fabrication cell, with defect-free laser cutting at speeds up to 400 inches per minute. The parts are then sent through a continuous flow of metal forming, welding, powder coating and assembly cells.



Our modern manufacturing and assembly facility

ensures that customers receive the quality products they've come to expect.

GLOBAL LOCATIONS

For worldwide Sales and Technical Support, visit: www.belden.com



UNITED STATES

Division Headquarters

401 Pennsylvania Parkway, #200
Indianapolis, IN
USA
Phone: (1)-317-818-6300
Inside Sales: 800-235-3361
Fax: (1)-317-818-6382
info@belden.com

Infrastructure Solutions Manufacturing Operations

2001 N. Main Street
Washington, PA 15301
USA
Phone: (1)-800-793-2954
(1)-724-228-7373
Fax: (1)-724-228-3920

CANADA

National Business Center

2280 Alfred-Nobel Boulevard
St-Laurent, Quebec
Canada
Phone: 514-822-2345
Fax: 514-822-7979
info@belden.com

BRAZIL

Regional Office

Rua Surubim, 577 - 4o andar
São Paulo, SP
Brazil
Phone: 5511-4097-2555
Fax: 5511-4097-2545
vendas@belden.com.br