



Installation Instructions for the Sliding Bar Interlock for 3-Pole F-Frame, and 2- and 3-Pole J- and K-Frame Series C Circuit Breakers and Molded Case Switches



WARNING

DO NOT ATTEMPT TO INSTALL OR PERFORM MAINTENANCE ON EQUIPMENT WHILE IT IS ENERGIZED. DEATH, SEVERE PERSONAL INJURY, OR SUBSTANTIAL PROPERTY DAMAGE CAN RESULT FROM CONTACT WITH ENERGIZED EQUIPMENT. ALWAYS VERIFY THAT NO VOLTAGE IS PRESENT BEFORE PROCEEDING WITH THE TASK, AND ALWAYS FOLLOW GENERALLY ACCEPTED SAFETY PROCEDURES.

CUTLER-HAMMER IS NOT LIABLE FOR THE MISAPPLICATION OR MISINSTALLATION OF ITS PRODUCTS.

The user is cautioned to observe all recommendations, warnings, and cautions relating to the safety of personnel and equipment, as well as, all general and local health and safety laws, codes, and procedures.

The recommendations and information contained herein are based on Cutler-Hammer experience and judgement, but should not be considered to be all-inclusive or covering every application or circumstance which may arise. If any questions arise, contact Cutler-Hammer for further information or instructions.

1. INTRODUCTION

General Information

The sliding bar interlock (Fig. 1-1) provides mechanical interlocking between two adjacent circuit breakers of the same pole configuration, preventing both circuit breakers from being switched to the ON position at the same time. The sliding bar interlock is secured to the outside of the enclosure cover between the circuit breakers. When the sliding bar interlock handle is moved from one side to the other, a bar extends to alternately block movement of the circuit breaker handles and prevents both circuit breakers being switched on at the same time. The sliding bar interlock is for field installation only. For this publication, the term circuit breaker shall also include molded case switch.

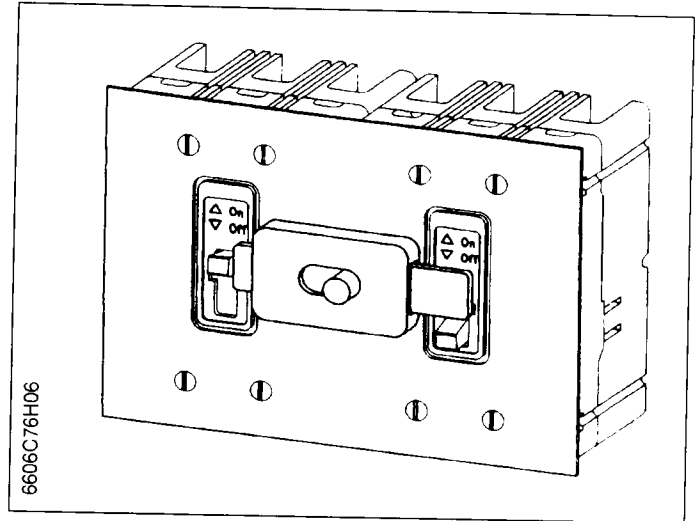

Fig. 1-1. Sliding Bar Interlock Installed Between Two F-Frame Series C Circuit Breakers

This instruction leaflet (IL) gives detailed procedures for installing the sliding bar interlock.

Sliding Bar Interlock Catalog Numbers are:

- F-frame – SBK1
- J-frame – SBK2
- K-frame – SBK3

2. INSTALLATION

The sliding bar interlock can be used between two 3-Pole F-frame, and two 2- or 3-Pole J- or K-frame circuit breakers or molded case switches. The mounting panel must be drilled to correspond with the interlock spacing requirements. To install the sliding bar interlock, perform the following steps:



WARNING

BEFORE ATTEMPTING ANY WORK ON CIRCUIT BREAKERS INSTALLED IN AN ELECTRICAL SYSTEM, MAKE SURE THE CIRCUIT BREAKERS ARE SWITCHED TO THE OFF POSITION AND THAT THERE IS NO VOLTAGE PRESENT WHERE WORK IS

TO BE PERFORMED. SPECIAL ATTENTION SHOULD BE PAID TO REVERSE FEED APPLICATIONS TO ENSURE NO VOLTAGE IS PRESENT. THE VOLTAGES IN ENERGIZED EQUIPMENT CAN CAUSE SEVERE PERSONAL INJURY OR DEATH.

Note: Only the interlock for one particular frame size has been provided in each kit. These instructions, however, cover installation of an interlock for F-, J-, or K-frame circuit breakers.

- 2-1. Refer to drilling plans for F-, J-, or K-frame circuit breakers (Fig. 2-1, 2-2, or 2-3); drill and tap circuit breaker mounting panel.

Note: Circuit breakers are secured to mounting panel by hardware supplied with circuit breaker.

- 2-2. Mount both circuit breakers to mounting panel.
- 2-3. Refer to Fig. 2-4 (F-frame), 2-5 (J-frame), or 2-6 (K-frame) and cut out enclosure cover to correct circuit breaker and trip unit escutcheon (J-/K-frame) dimensions.

Note: Before doing the next step, determine the thickness of the enclosure front panel. Table 2-1 gives hole sizes for the various thicknesses of enclosure front panels.

Table 2-1. Drilling Details for Enclosure Front Panels in Inches (Millimeters)

Panel Thickness	Hole Size (Dia.) ①
.125 (3.17)	.257 (6.53)
.188 (4.77)	.201 (5.10)

① Countersink holes 82° to .475 (12.06) Dia.

- 2-4. Referring to Fig. 2-4, 2-5, or 2-6, and Table 2-1, drill and countersink four interlock mounting holes in the back of the enclosure front panel.
- 2-5. Mount the components of the interlock in the following manner (Fig. 2-7):
- a. Insert one .190-32 inch flat head, countersunk screw with lockwasher through one interlock mounting hole in the enclosure front panel.

Note:The .053-inch (1.35 mm) spacer is only for use with F- and J-frame circuit breakers installed in enclosures with a front panel thickness of .125 inch (3.17 mm). This spacer should be discarded when the panel thickness is .188 inch (4.77 mm.)

The .125-inch (3.17 mm) spacer is only for use with K-frame circuit breakers installed in enclosures with a front panel thickness of .125 inch (3.17 mm). This spacer should be discarded when the panel thickness is .188 inch (4.77 mm.)

- b. When the front panel thickness is .125 inch (3.17 mm), select the correct spacer and position over the mounting screw.

Note:The .081-inch (2.06 mm) slotted spacer is for use with F- and J-frame circuit breakers.

The .094-inch (2.39 mm) slotted spacer is for use with K-frame circuit breakers.

- c. Select the correct slotted spacer for the circuit breakers in use and position over the mounting screw.
- d. Position the wave spring in the slotted spacer with the central crest towards the enclosure panel.
- e. Position the slider and knob assembly in the housing with the knob through the slot in the housing.
- f. Hold the slider and knob assembly and housing against the spacer(s) and wave spring. Thread the screw into the housing.
- g. Thread the three remaining flat head, countersunk screws and lockwashers into the housing. Tighten the four mounting screws.
- 2-6. Carry out functional check. Make sure that both circuit breakers cannot be switched to the ON position at the same time; also, confirm that each circuit breaker can be closed when the other is open.
- 2-7. Connect circuit breakers as required.

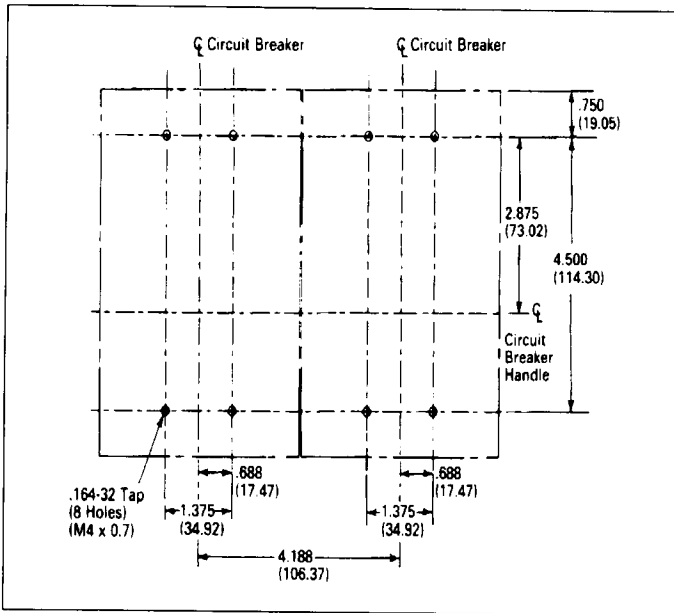

Fig. 2-1. F-Frame Circuit Breaker Mounting Bolt Drilling Plan

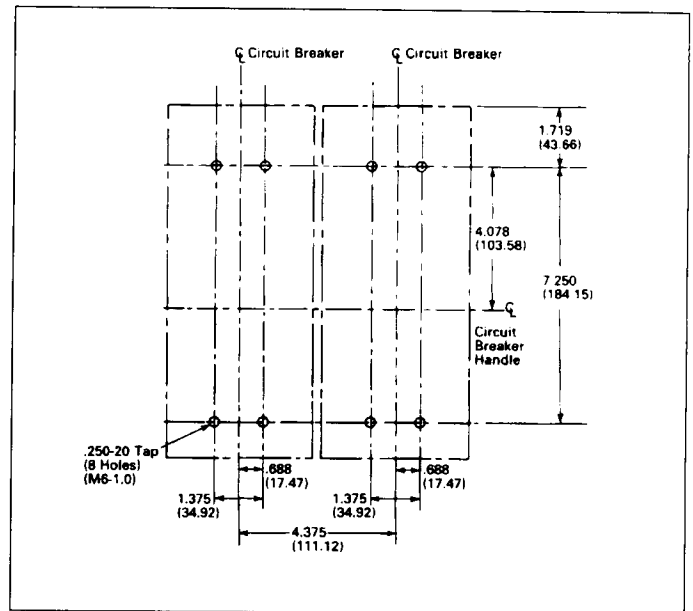

Fig. 2-2. J-Frame Circuit Breaker Mounting Bolt Drilling Plan

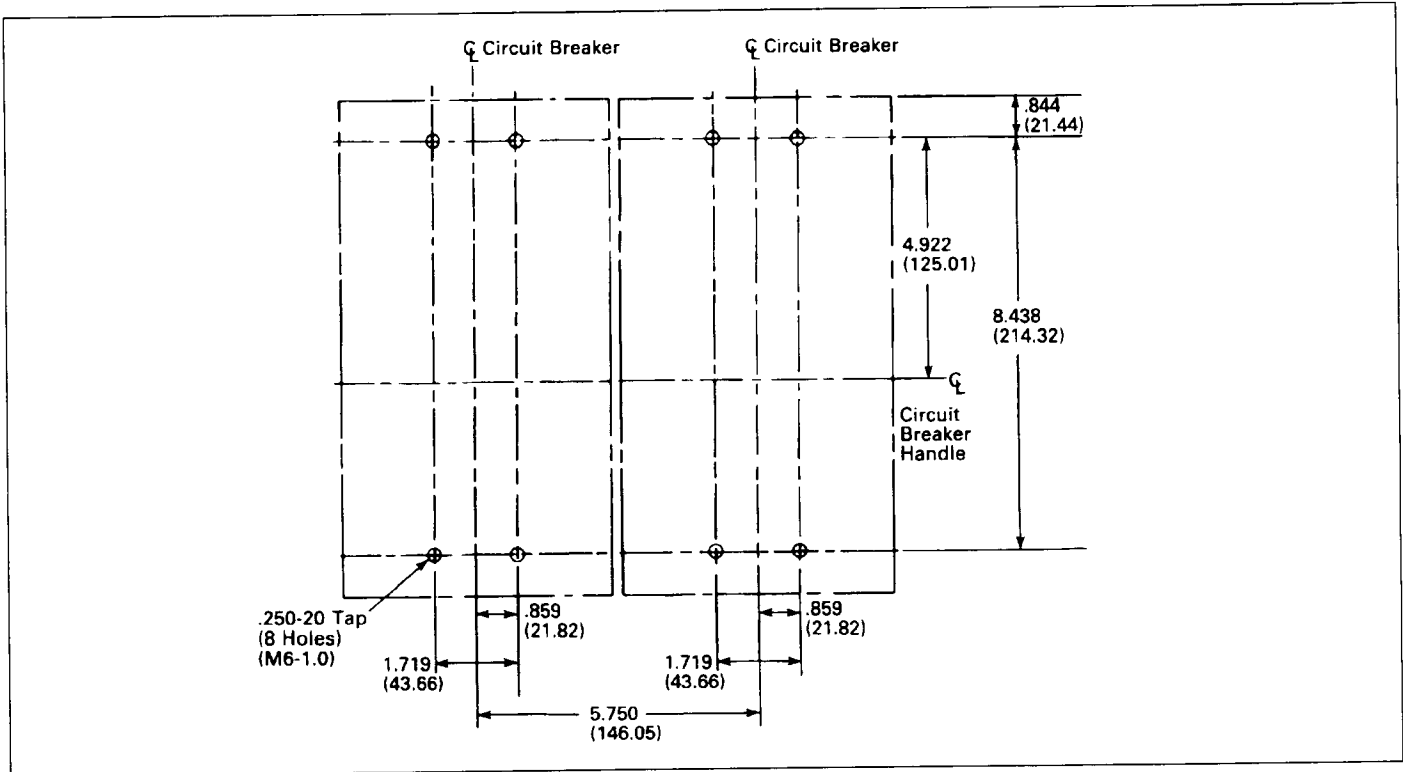

Fig. 2-3. K-Frame Circuit Breaker Mounting Bolt Drilling Plan

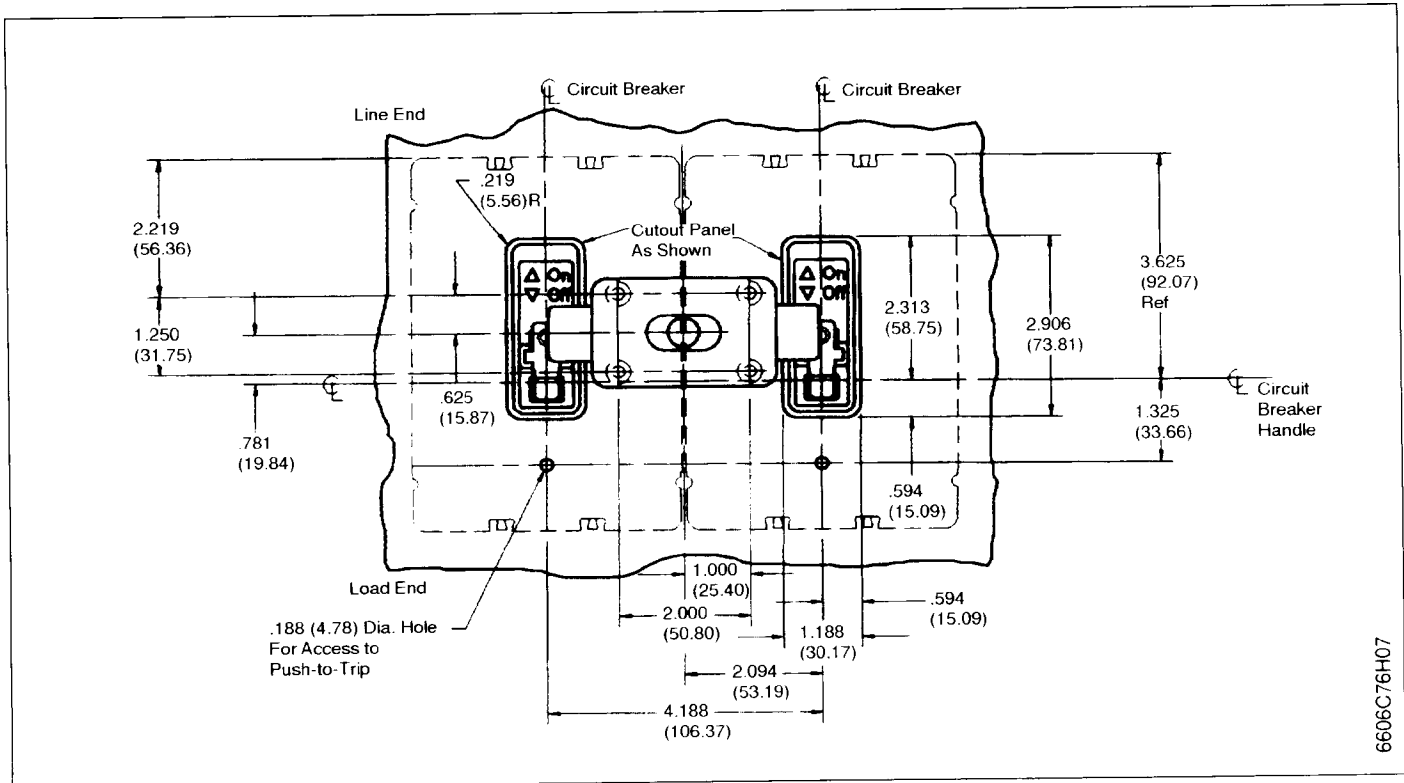

Fig. 2-4. F-Frame Sliding Bar Interlock Installation Details

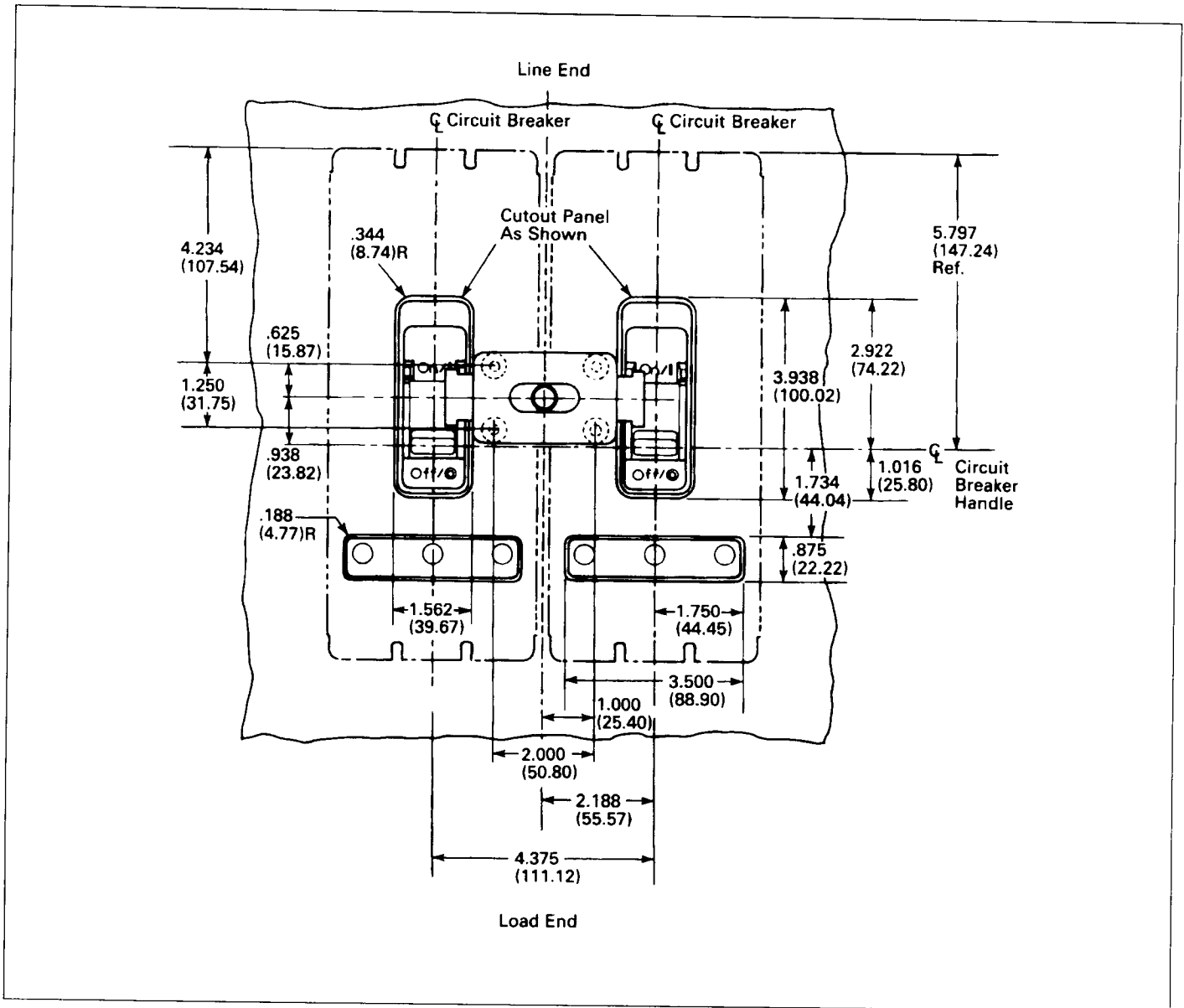

Fig. 2-5. J-Frame Sliding Bar Interlock Installation Details

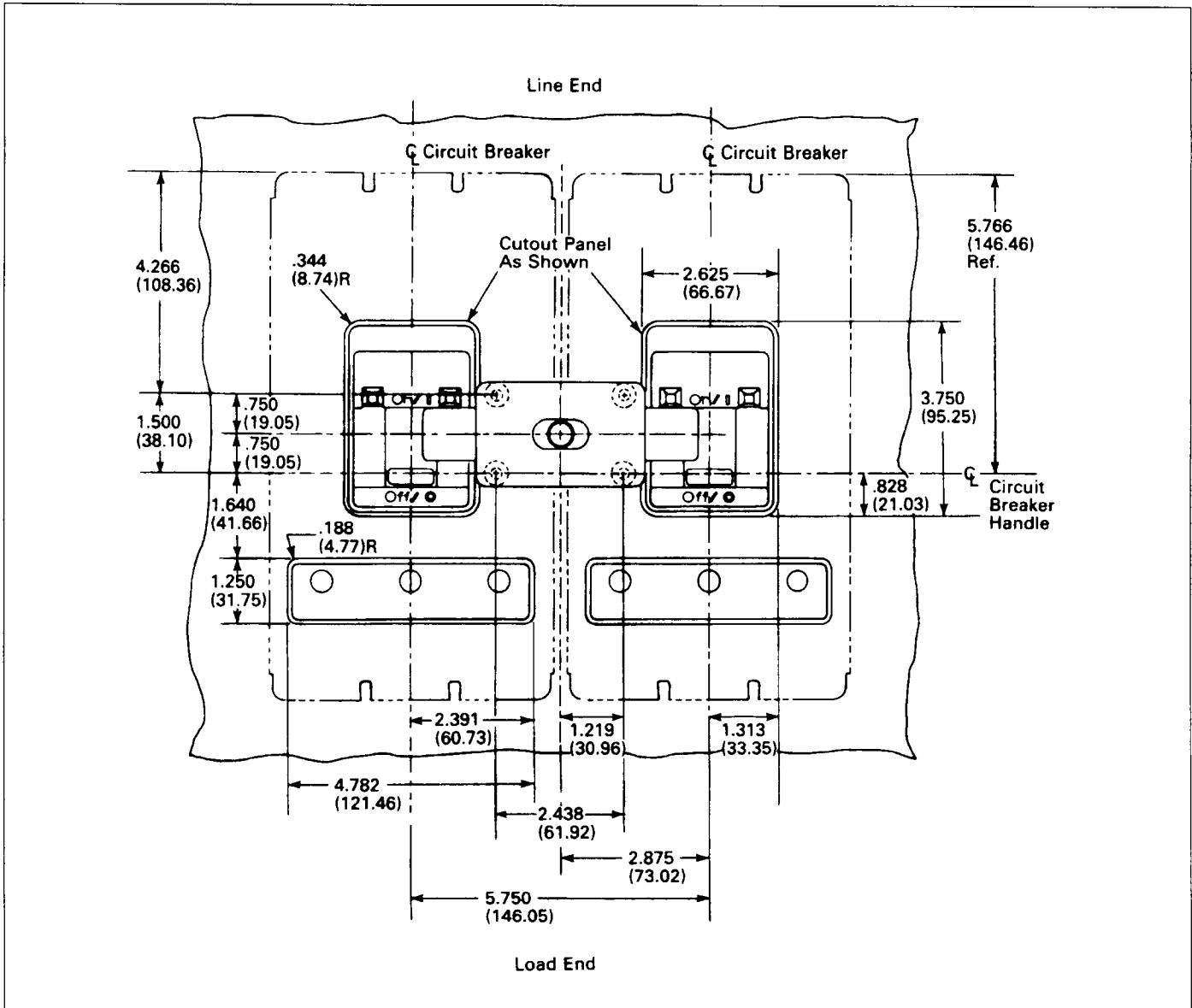

Fig. 2-6. K-Frame Sliding Bar Interlock Installation Details

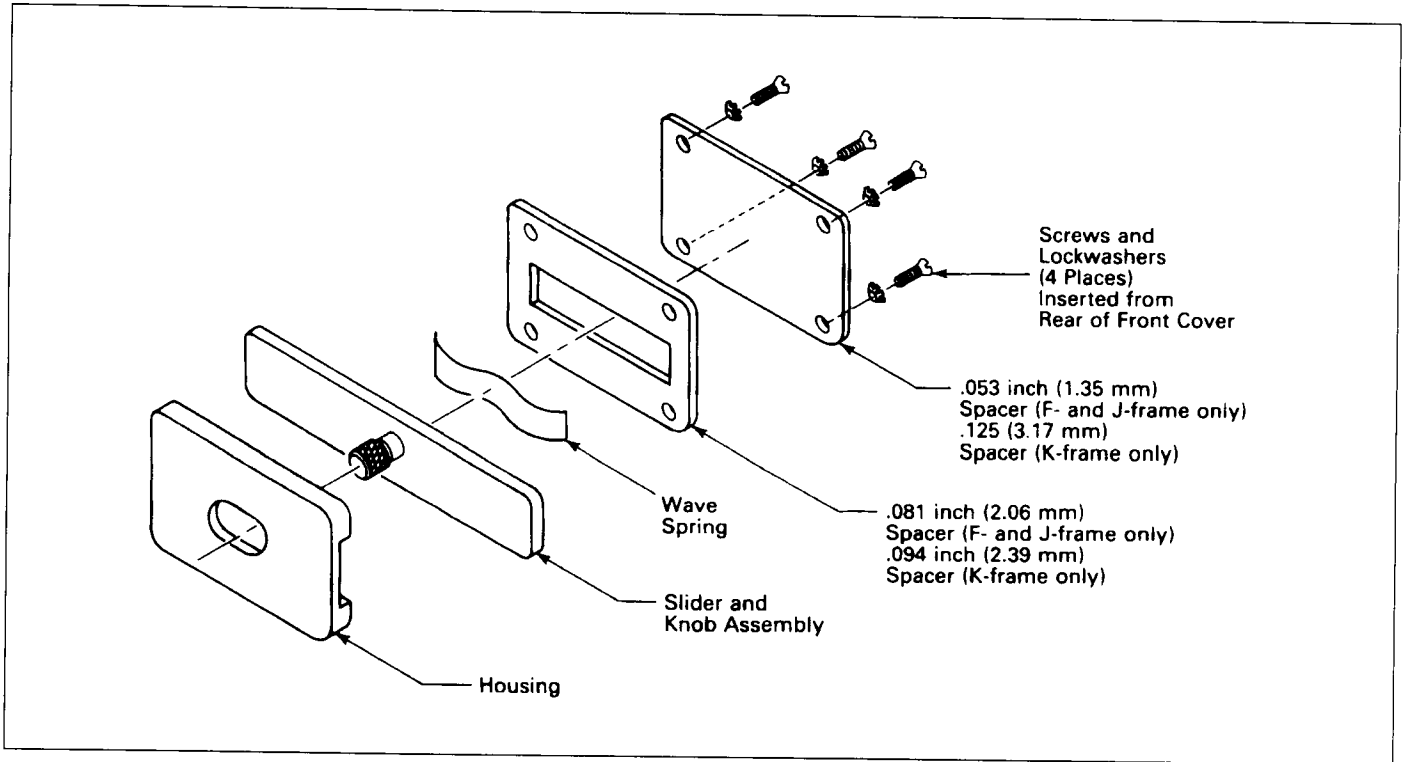

Fig. 2-7. Assembly Sequence of Sliding Bar Interlock Components

Cutler-Hammer

Pittsburgh, Pennsylvania U.S.A.

Style No. 6620C54H03 Effective November 1998
Printed in U.S.A./CCI

