

PURGE AND PRESSURIZATION SYSTEMS



INDUSTRY STANDARDS

Type X

Ex [px] Ex [p]
IECEx SIR.0019X [Gb, Db]
Europe, ATEX Category 2 GD
Cert no Sira 14ATEX1045X
USA/Canada NFPA496 Cl I Div 1 Groups A, B, C & D
UL E466718

Type Y

Ex [py] Ex [p]
IECEx SIR.0019X [Gb, Db]
Europe, ATEX Category 2 GD
Cert no Sira 14ATEX1045X
North America Cl I Div 1 Groups A, B, C & D
For protecting Cl I Div 2 equipment
UL E466718

Type Z

Ex [pz] Ex [p]
IECEx SIR.0019X [Gc, Dc]
Europe, ATEX Category 3 GD
Cert no Sira 14ATEX1045X
North America Cl I Div 2 Groups A, B, C & D
UL E466718

APPLICATION

Purge and Pressurization is a protection method used with Type 4, 4X and 12 (IP54 recommended minimum) enclosures. The enclosure is initially purged to remove any internal explosive gases or dust. Once this is accomplished, the enclosure is pressurized with a protective air or inert gas supply. This provides a positive internal enclosure pressure which keeps any external explosive gases or dust from entering the enclosure.

The two methods of purge and pressurization offered are Leak Compensation and Continuous Flow.

Leak Compensation

Maintains positive pressure by compensating for losses. System consists of Control Unit and Relief Valve.

Certification Type Y and Z models

- Flush (internal) or external mount models

Purge and Pressurization Systems and Certifications

Protection Type	Division (North American, NFPA 496)	Zones (IEC / ATEX)
Y	Enclosures placed in Division 1 classification area may contain Division 2 internal components	Enclosures placed in Zone 1 classification area may have Zone 2 internal components
Z	Enclosures placed in Division 2 classification area may contain general purpose internal components	Enclosures placed in Zone 2 classification area may have general purpose internal components
X	Enclosures placed in Division 1 classification area may contain general purpose internal components	Enclosures placed in Zone 1 classification area may have general purpose internal components

Standard Product Purge and Pressurization

Catalog Number	Operation Type	Mounting Type	Certification
PLCF1YZ	Leak Compensation	Flush Mount	Y and Z
PLCB1YZ	Leak Compensation	Exterior Mount	Y and Z
PCFF1YZ	Continuous Flow	Flush Mount	Y and Z
PCFB1YZ	Continuous Flow	Exterior Mount	Y and Z
PLCS1X1	Leak Compensation	Exterior Mount	X (120 VAC)
PLCS1X2	Leak Compensation	Exterior Mount	X (230 VAC)

- Local visual alarm indicator and dry contact output for remote alarm
- Typically recommended for enclosures with volume of 60 Ft³ or less

Certification Type X Model

- Provides power disconnect when pressurization is lost or not attained
- Provides automatic purge process
- External mount
- Local visual alarm indicator and dry contact output for remote alarm
- Typically recommended for enclosures with volume of 60 Ft³ or less

Continuous Flow

Provides positive pressure via continuous protective air flow through the enclosure. System consists of Control Unit, Calibrated Outlet Orifice and Relief Valve.

Certification Type Y and Z Models

- Flush (internal) or external mount models
- Local visual alarm indicator and dry contact output for remote alarm
- Typically recommended for enclosures with volume of 17 Ft³ or less. Larger enclosures can use Continuous Flow models but will require longer purging times.

FEATURES

- All exterior components are 316 stainless steel or corrosion-resistant composite
- Space-saving flush or exterior mounted models available
- Local visual indicators provide system status
- Leak compensation models are equipped with rapid purge valve and visual purge status indicator
- All models utilize dry, clean inert gas supply of 60 PSI (4 bar) to 115 PSI (8 bar)
- Ambient operating temperature -4F (-20C) to 131F (55C)
- Type X models provide automatic purge cycle and 4PNO/20A/440VAC power contactor with 115 VAC or 230 VAC coil

FINISH

Brushed 316 Stainless Steel

OPTIONS

Service Parts Kit for both Leak Compensation and Continuous Flow models

MODIFICATION AND CUSTOMIZATION

Hoffman excels at modifying and customizing products to your specifications. Cutouts for mounting purge and pressurization devices can be easily added to your enclosure. Contact your local Hoffman Representative or Distributor for more information.

Note:

For all IEC and ATEX applications, the final or complete integrated assembly must be submitted to a notified body for certification.

BULLETIN: HLP

Service Kits

Catalog Number	Description
PLCSKIT	Purge and Pressurization Leakage Compensation Service Kit
PCFSKIT	Purge and Pressurization Continuous Flow Service Kit

PLCF1YZ

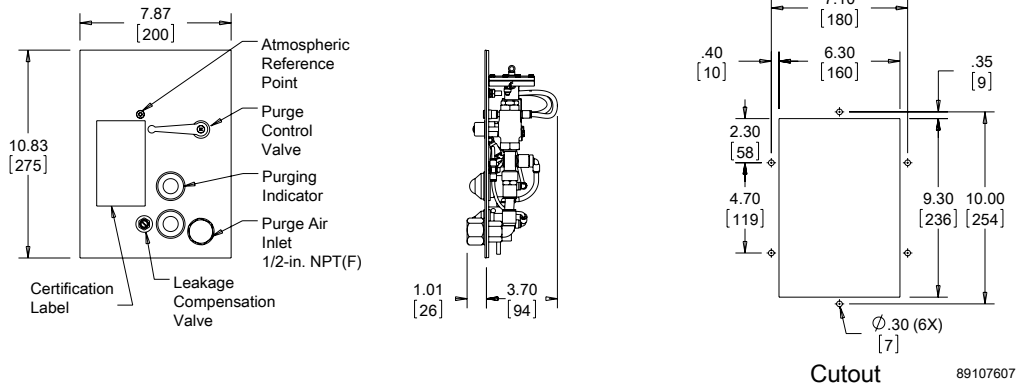

PLCB1YZ

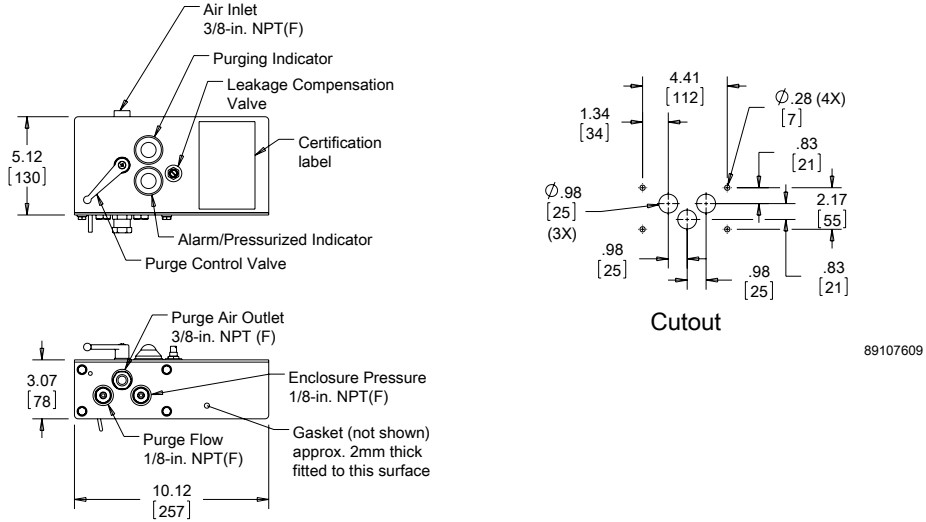

PCFF1YZ

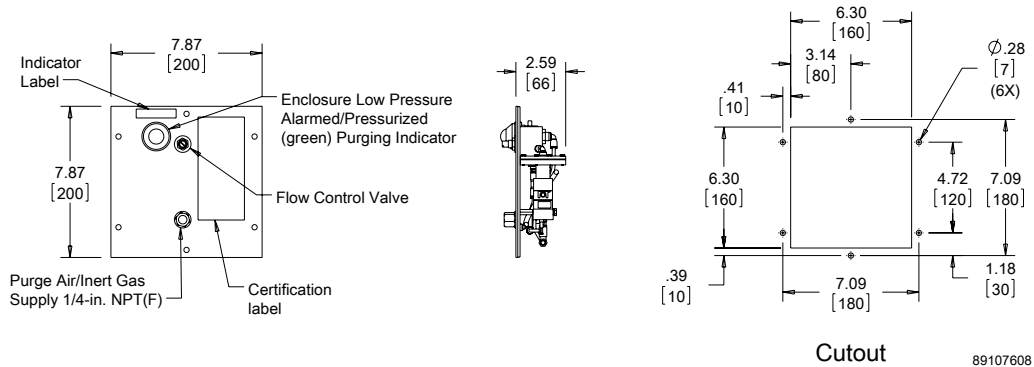

PCFB1YZ

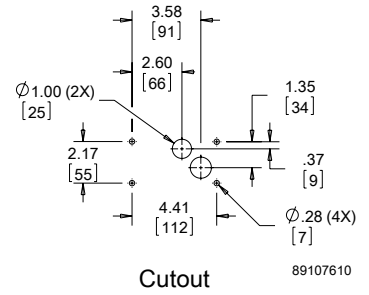
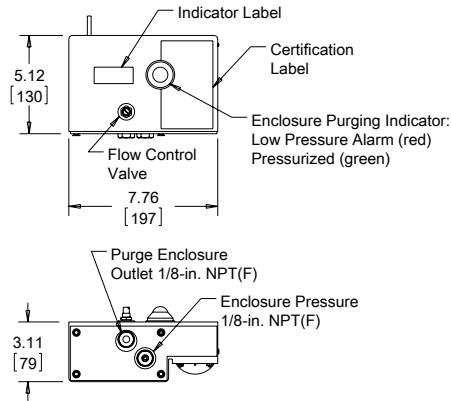

PLCS1X1, PLCS1X2

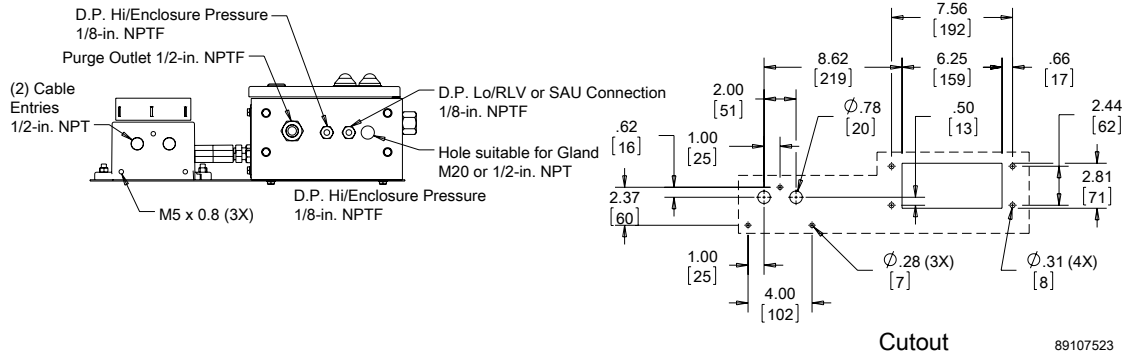
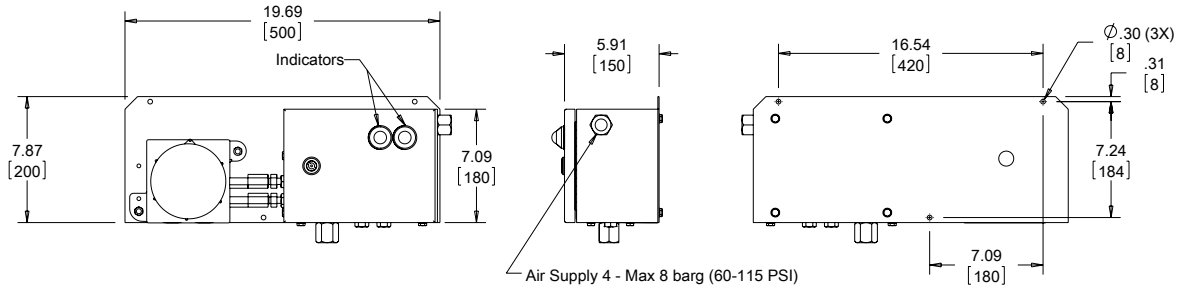

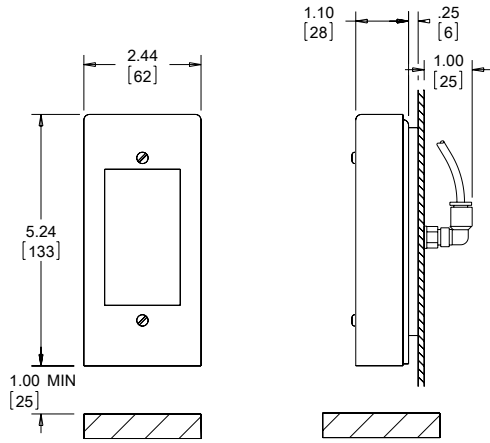

Relief Valve

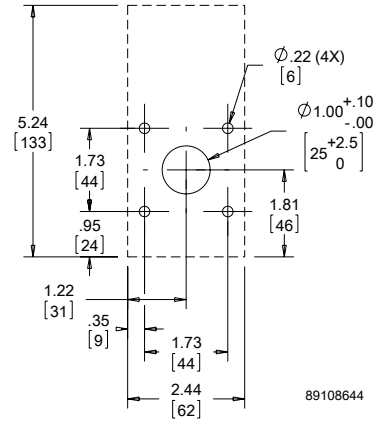

Cutout

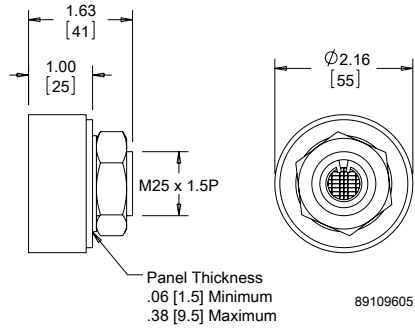

Outlet Orifice for Continuous Flow Models