

M-12698

2

CONFIGURATION TABLE

CAT NO.	CONFIGURATION	RATING	LENGTH	WIDTH	CABLE DIA. RANGE	HSG MAT'L	HSG COLOR
HBSL330C4W HBSL332C4W		30A 125 VAC 2HP 32A 100-130 VAC	9.9 +/- .07 in. 251.5 +/- 1.8 mm	4.5 +/- .07 in. 114.3 +/- 1.8 mm	CABLE DIA.: .50" min. / 1.25" max. 12.7 mm min/32 mm max	PET	YELLOW
HBSL330C6W		30A 250 VAC 5 HP 32A 220-240 VAC	9.9 +/- .07 in. 251.5 +/- 1.8 mm	4.5 +/- .07 in. 114.3 +/- 1.8 mm	CABLE DIA.: .50" min. / 1.25" max. 12.7 mm min/32 mm max	PET	RED
HBSL330C7W		30A 480 VAC 10 HP	9.9 +/- .07 in. 251.5 +/- 1.8 mm	4.5 +/- .07 in. 114.3 +/- 1.8 mm	CABLE DIA.: .50" min. / 1.25" max. 12.7 mm min/32 mm max	PET	RED
HBSL432C3W		32A 380-440 VAC	9.9 +/- .07 in. 251.5 +/- 1.8 mm	4.5 +/- .07 in. 114.3 +/- 1.8 mm	CABLE DIA.: .50" min. / 1.25" max. 12.7 mm min/32 mm max	PET	RED
HBSL430C5W		30A 3Φ 600 VAC 30 HP	9.9 +/- .07 in. 251.5 +/- 1.8 mm	4.5 +/- .07 in. 114.3 +/- 1.8 mm	CABLE DIA.: .50" min. / 1.25" max. 12.7 mm min/32 mm max	PET	BLACK
HBSL430C6W		30A 380-415 VAC 7.5 HP 32A 380-415 VAC	9.9 +/- .07 in. 251.5 +/- 1.8 mm	4.5 +/- .07 in. 114.3 +/- 1.8 mm	CABLE DIA.: .50" min. / 1.25" max. 12.7 mm min/32 mm max	PET	RED
HBSL430C7W		30A 3Φ 480 VAC 20 HP	9.9 +/- .07 in. 251.5 +/- 1.8 mm	4.5 +/- .07 in. 114.3 +/- 1.8 mm	CABLE DIA.: .50" min. / 1.25" max. 12.7 mm min/32 mm max	PET	RED
HBSL430C9W		30A 3Φ 250 VAC 10 HP 32A 3Φ 250 VAC	9.9 +/- .07 in. 251.5 +/- 1.8 mm	4.5 +/- .07 in. 114.3 +/- 1.8 mm	CABLE DIA.: .50" min. / 1.25" max. 12.7 mm min/32 mm max	PET	BLUE
HBSL430C12W		30A 125/250 VAC 2 HP	9.9 +/- .07 in. 251.5 +/- 1.8 mm	4.5 +/- .07 in. 114.3 +/- 1.8 mm	CABLE DIA.: .50" min. / 1.25" max. 12.7 mm min/32 mm max	PET	ORANGE
HBSL530C5W		30A 3Φ 347/600 VAC 30HP	10.0 +/- .07 in. 254 +/- 1.8 mm	4.8 +/- .07 in. 122 +/- 1.8 mm	CABLE DIA.: .50" min. / 1.45" max. 12.7 mm min/32 mm max	PET	BLACK
HBSL530C6W		30A 200/346 - 240/415 VAC 7.5 HP 32A 220/415 VAC	10.0 +/- .07 in. 254 +/- 1.8 mm	4.8 +/- .07 in. 122 +/- 1.8 mm	CABLE DIA.: .50" min. / 1.45" max. 12.7 mm min/32 mm max	PET	RED
HBSL530C7W		30A 3Φ 277/480 VAC 20 HP	10.0 +/- .07 in. 254 +/- 1.8 mm	4.8 +/- .07 in. 122 +/- 1.8 mm	CABLE DIA.: .50" min. / 1.45" max. 12.7 mm min/32 mm max	PET	RED
HBSL530C9W		30A 3Φ 120/208 VAC 10 HP 32A 3Φ 120/208 VAC	10.0 +/- .07 in. 254 +/- 1.8 mm	4.8 +/- .07 in. 122 +/- 1.8 mm	CABLE DIA.: .50" min. / 1.45" max. 12.7 mm min/32 mm max	PET	BLUE

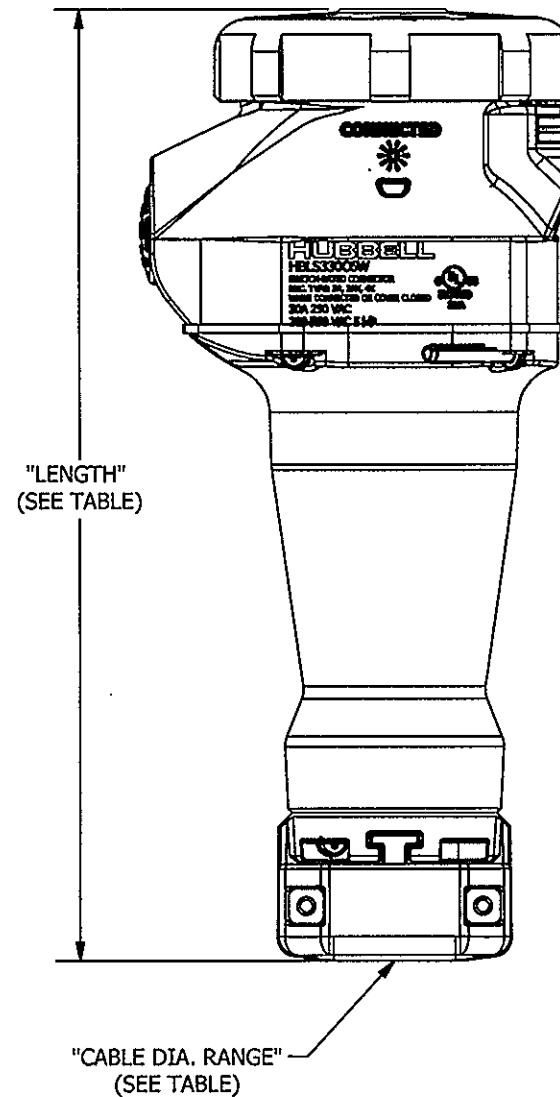
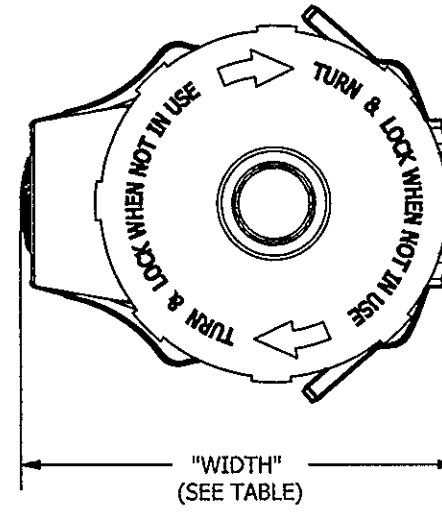

LIST OF PARTS

DESCRIPTION	MATERIAL	FINISH
HOUSING	PET	
INTERIOR	NYLON	
SLEEVES	BRASS	
PHASE, NEUTRAL & GND CONTACTS	BER. COPPER	SILVER
TERMINAL SCREWS	SS	
HINGE & LID	PET	
HINGE PIN & SPRING	SS	
GLAND CAP	PET	
GLAND CLAMPS	PET	
CLAMP NUTS	BRASS	NICKEL
ASSY SCREWS	SS	
GLAND	NEOPRENE	
LED WINDOW	POLYCARBONATE	
HOUSING GASKET	RUBBER	

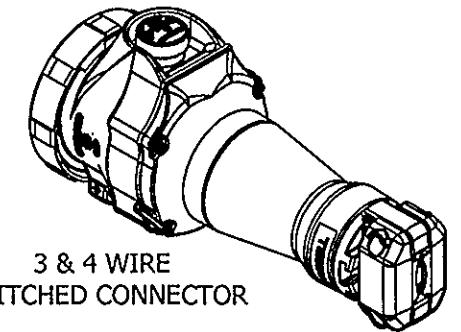

3 & 4 WIRE SWITCHED CONNECTOR

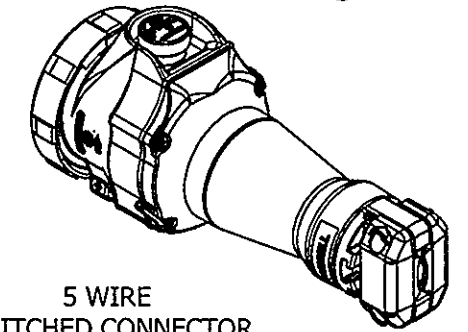

5 WIRE SWITCHED CONNECTOR

2	IN TABLE ADDED 32A RATINGS TO CAT#'S HBSL430C9W AND HBSL530C9W PER DCN 21005. MYA	WHD	2/26/2015	<input checked="" type="checkbox"/>
1	RELEASED FOR PRODUCTION PER DCN 20636 WHD 11/10/14			
SYM	DESCRIPTION	APPRO	DATE	

THE DESIGN AND DIMENSIONS OF THE PRODUCT SHOWN ON THIS DRAWING ARE SUBJECT TO CHANGE WITHOUT NOTICE

TITLE  
30 & 32A 2W/3P, 3W/4P & 4W/5P PIN & SLEEVE SWITCHED CONNECTORS

TOLERANCES UNLESS OTHERWISE SPECIFIED	WIRING DEVICE-KELLEMS HUBBELL INCORPORATED SHELTON, CT	
FRACTIONS ±1/64	DR. BY wdietz	APP. BY
DECIMALS ±.005	TR. BY WHD	SCALE
ANGLES ±2'	CHK'D BY	DATE 11/6/2014

DIMENSION SHEET FOR CAT. NO.

REPAIRABLE

NON-REPAIRABLE

B

M-12698

2