

Raceway  
Non-Metallic Raceway  
PL1 LANTrak® (Latching) External Elbow  
Base and Cover

# HUBBELL

### Features

- Full capacity 1¼ in. bend radius external elbow.

### Ordering Information

Description	Color	UPC Number	Catalog Number
External Elbow Base and Cover	Office White	783585090269	PL1EEBC

### Listings

UL Listed  
CSA Certified

### Specifications

Height	1.57"
Width	5.06"
Length	5.06"

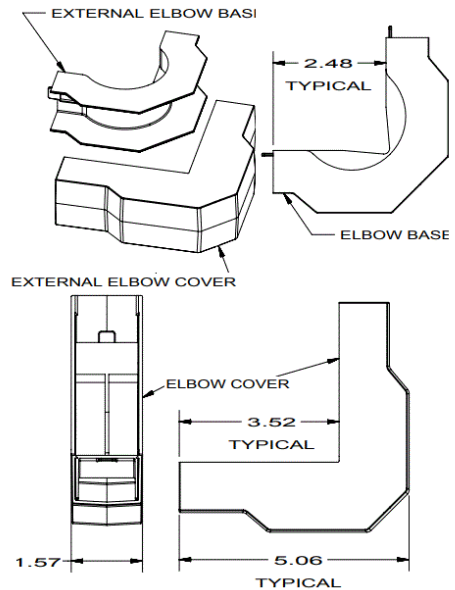
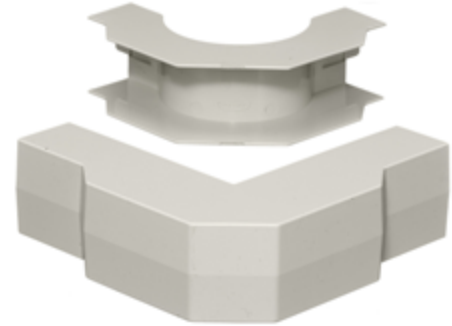

### Online Resources

Customer Use Drawing  
eCatalog  
Installation Instructions

Dimensions in Inches (mm)

Hubbell Wiring Device-Kellems • Hubbell Incorporated (Delaware) • 40 Waterview Drive • Shelton, CT 06484

Phone (800) 288-6000 • Fax (800) 255-1031 • Specifications subject to change without notice.

