

THIS COPY IS PROVIDED ON A RESTRICTED BASIS AND IS NOT TO BE USED IN ANY WAY DETRIMENTAL TO THE INTERESTS OF PANDUIT CORP.

NOTES:

1. VISIT OUR ON-LINE CATALOG AT WWW.PANDUIT.COM FOR A LIST OF CURRENT PARTS APPLICABLE FOR USE WITH THIS PRODUCT.
2. WHITE COLOR WIRE CAP ASSEMBLY DESIGNATES TIA CATEGORY 6 (ISO 11801 CLASS E) PERFORMANCE.
3. COLOR OF JACK MODULE IS INDICATED BY ** IN THE PART NUMBER (EXAMPLE: CJS688TGBUY FOR BLUE JACK). SEE WWW.PANDUIT.COM FOR AVAILABLE COLOR CODES.
4. PART NUMBERS OF AVAILABLE PACKAGE TYPES ARE SHOWN IN TABLE 1.
5. TERMINATION TOOL TO BE USED IS EGJT-1. SOME PACKAGE TYPES INCLUDE A TERMINATION TOOL, SEE TABLE 1 FOR DETAILS.
6. ALL MINI-COM™ CATEGORY 6, 8 POSITION, 8 WIRE CONNECTOR MODULES ARE UNIVERSAL IN DESIGN. THEY ACCEPT ACCEPT SIX AND EIGHT POSITION MODULAR PLUGS WITHOUT DAMAGE.
7. TERMINATES 22-26AWG SOLID OR STRANDED UTP CABLE LEFT AND RIGHT HORIZONALLY.
8. SEE INSTALLATION INSTRUCTION FOR PROPER TERMINATION METHOD.
9. WIRE CAP LABEL WHICH IS PART OF THE WIRE CAP ASSEMBLY IS CODED FOR T568A AND T568B WIRING SCHEMSE.
10. PART INCLUDES:
 MODULE HOUSING: ABS W/ UL94V-0 FLAME RATING.
 MODULE SHIELD: TIN PLATED OVER PHOPHORUS BRONZE
 WIRE CAP ASSEMBLY: DIE CAST ZINC AND POLYCARBONATE W/ UL94V-0 FLAME RATING.
11. WEIGHT: 3.314 LBS/100 PCS (1503 g/100 PCS).
12. DIMENSIONS IN [] ARE METRIC.
13. 0.187" X 0.010" GROUNDING TAB PROVIDED AS OPTIONAL CONDUCTIVE PATH FOR GROUNDING.
13. ALL MATERIALS AND COMPONENTS USED MEET THE LATEST RoHS REQUIREMENTS.

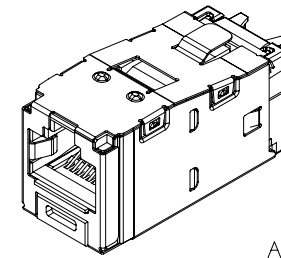
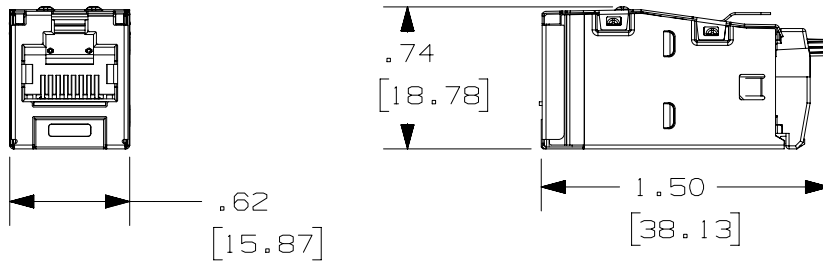
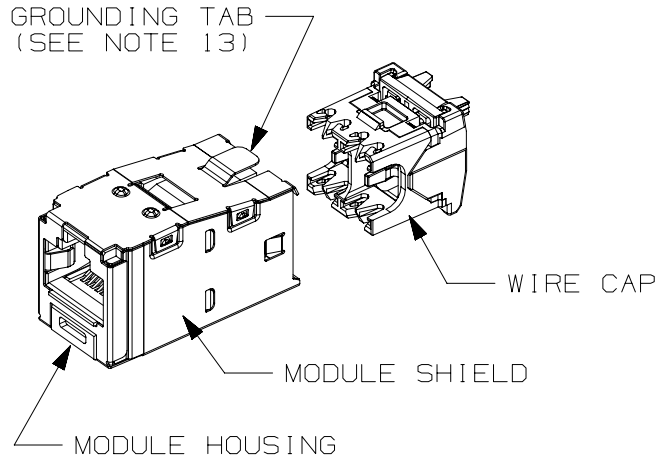
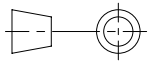

TABLE 1: PACKAGE TYPE AND TERMINATION TOOL

PART NUMBER	PACKAGED QUANTITY	TERMINATION TOOL: EGJT-1
CJS688TG**Y	INDIVIDUAL PACKAGED, 50 PER CARTON	NOT INCLUDED
CJS688TG**Y-24	BULK PACKAGED, 24 PER BAG	INCLUDED (1 PER BAG)

PART NUMBER		SEE TABLE 1	
TITLE			
TX6 PLUS™ SHIELDED JACK MODULE		CUSTOMER DRAWING	
ITEM REVISION NAME		M02479NS/08	
DATASET FILE NAME		M02479NS_DC357/08C	
		THIRD ANGLE PROJECTION	
MATERIAL		SEE NOTE 10	
DRAWING NUMBER		02479-357	
DRAWN BY	DATE	CHK	SCALE
AFW	3-11-06	CEF	FULL
REV	DATE	BY	CHK
7	10-30-18	BJN	DCS
DESCRIPTION		ECN	
UPDATED NOTES; ADDED TABLE 1		00153LAL-02	
SHEET 1 OF 1		A	

A-SIZE CUSTOMER

2

1

2

1