

THIS COPY IS PROVIDED ON A RESTRICTED BASIS AND IS NOT TO BE USED IN ANY WAY DETRIMENTAL TO THE INTERESTS OF PANDUIT CORP.

PANDUIT PART NUMBER **	PANEL THICKNESS	A ±TOL.	B ±0.015 (0.38)	C ±0.015 (0.38)	D +0.020 (0.51) -0.015 (0.38)	E REF.	F * ±TOL.	G * REF
GE_36F-C	0.026 - 0.036 (0.66 - 0.91)	0.025 ±0.010 (0.64 ±0.25)	0.045 (1.14)	0.087 (2.21)	0.030 (0.76)	0.106 (2.69)	0.060 +0.005 (0.13) (1.52) -0.025 (0.64)	0.150 (3.81)
GE_62F-C	0.036 - 0.062 (0.91 - 1.57)	0.035 ±0.013 (0.89 ±0.33)	0.070 (1.78)	0.130 (3.30)	0.030 (0.76)	0.131 (3.33)	0.105 +0.005 (0.13) (2.67) -0.025 (0.64)	0.150 (3.81)
GE_99F-C	0.062 - 0.099 (1.57 - 2.51)	0.054 ±0.013 (1.37 ±0.33)	0.108 (2.74)	0.155 (3.94)	0.030 (0.76)	0.169 (4.29)	0.125 +0.005 (0.13) (3.18) -0.025 (0.64)	0.150 (3.81)
GE_144F-C	0.099 - 0.144 (2.51 - 3.66)	0.090 ±0.013 (2.29 ±0.33)	0.152 (3.86)	0.192 (4.88)	0.030 (0.76)	0.213 (5.41)	0.160 +0.005 (0.13) (4.06) -0.035 (0.89)	0.150 (3.81)
*** GES189F-C	0.144 - 0.189 (3.66 - 4.80)	0.12 ±0.030 (3.2 ±0.76)	0.206 (5.23)	0.255 (6.48)	0.046 (1.17)	0.297 (7.55)	—————	—————

NOTES:

- \* 1) DIM'S F & G APPLY ONLY TO SLOTTED GROMMET EDGING.
- \*\* 2) PART NO. EXAMPLE:

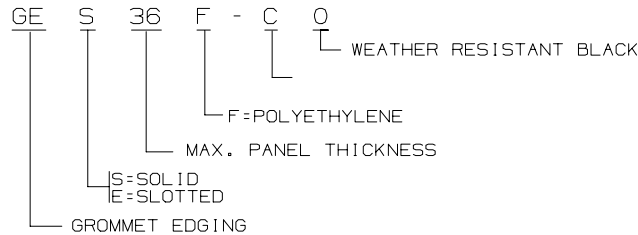

- 3) SEE CURRENT PRICE SHEET FOR PART NO. SUFFIX DESIGNATION FOR PACKAGE SIZE.
- 4) COLOR: a) NATURAL  
b) -0 AFTER PART NO. DENOTES WEATHER RESISTANT BLACK
- 5) SLOTTED WALL STYLE IS RECOMMENDED FOR INSIDE EDGE OF PANEL CUT OUTS. SOLID WALL STYLE IS RECOMMENDED FOR STRAIGHT, OUTSIDE EDGES.
- 6) REELS MAY CONTAIN A MAXIMUM OF THREE SPLICES.
- 7) MAXIMUM USE TEMPERATURE 122° (50° C)
- 8) THIS PART NUMBER ONLY AVAILABLE IN SOLID.

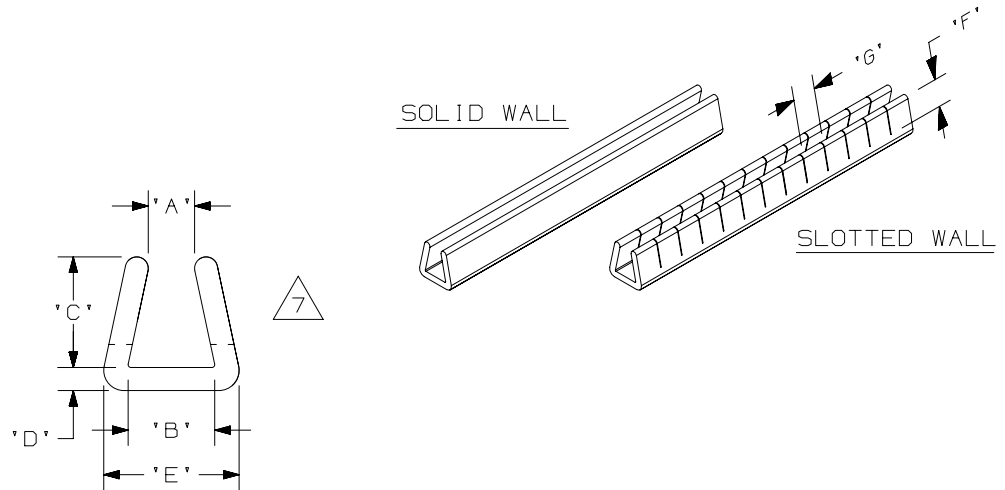

REV	DATE	BY	CHK	APR	DESCRIPTION	ECN
7	6/16/17	RVU	CLW	JHAC	ADD FRONT VIEW WITH ALL A, B, C, D, E, F, AND G DIMENSIONS TO MATCH WITH TABLE.	GAECN04200
6	02.16.15	BDK	MRJS	RGRO	F. ADDED NOTE #7 MAXIMUM TEMPERATURE RATING. G. GES189F-C WAS GE_189F-C AND ADDED NOTE 8.	GB0239FU

TITLE		ROLL FORM GROMMET EDGING	
CUSTOMER DRAWING			
ITEM REVISION NAME		G03597DM/02	
DATASET FILE NAME		G03597DM_DC_GB0239FU_07/02B	
UNLESS OTHERWISE SPECIFIED, DIMENSIONAL TOLERANCES ARE: IN ( mm )		MATERIAL:	
.X ± .XX ±		SEE NOTE #2	
.XXX ± ANGLES ±		DRAWING NUMBER:	
THIRD ANGLE PROJECTION		GB0239FU	
DRAWN BY	DATE	CHK	SCALE
CEW	5-24-85		NONE
SHT 1 OF 1		A	