

THIS COPY IS PROVIDED ON A RESTRICTED BASIS AND IS NOT TO BE USED IN ANY WAY DETRIMENTAL TO THE INTERESTS OF PANDUIT CORP.

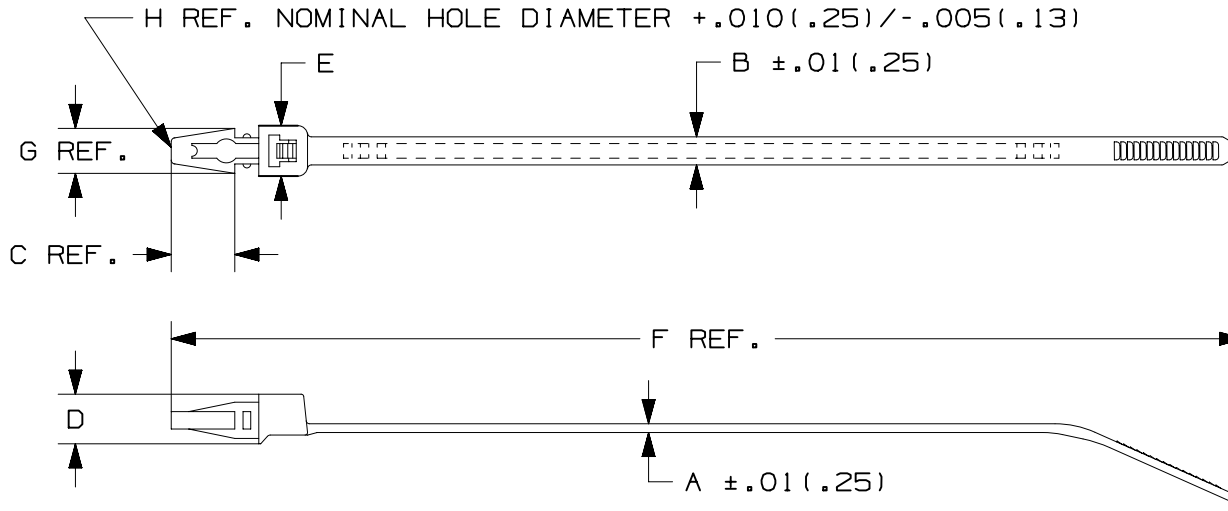

PANDUIT * PART NO.	BUNDLE DIA.		A in. (mm)	B in. (mm)	C in. (mm)	D in. (mm)	E in. (mm)	F in. (mm)	G in. (mm)	H in. (mm)	MAX PANEL THICKNESS in (mm)	MIN. LOOP TENSILE lbs (N)	CROSS- SECTION	WEIGHT lbs/100pcs (g)
	MIN in (mm)	MAX in (mm)												
PLP1.5I	.06 (1.5)	1.25 (31.8)	.045 (1.1)	.135 (3.4)	.350 (8.9)	.236 (6.0)	.270 (6.9)	6.13 (156)	.260 (6.6)	.187 (4.7)	.093 (2.4)	40 (178)	INTERMEDIATE	.17 (77)

NOTES:

- * 1) SEE www.panduit.com FOR PART NUMBER SUFFIX DESIGNATION FOR PACKAGE SIZE, PART MATERIAL, PART COLOR AND ANY THIRD PARTY RECOGNITION OR COMPLIANCE
- 2) SEE DRAWING 22-26803(A) FOR PLP1S, PLP1.5S & PLP2S.

REV	DATE	BY	CHK	APR	DESCRIPTION	ECN	TITLE	ITEM REVISION NAME	DATASET FILE NAME	MATERIAL:	DRAWING NUMBER:	
							STRAP, PUSH MOUNT - PLP	10B0150X/04	10B0150X_DC_PLP1.5I/04A	NYLON 6.6	SS-26888	
							CUSTOMER DRAWING					
							UNLESS OTHERWISE SPECIFIED, DIMENSIONAL TOLERANCES ARE: IN [mm]					
							.x ± .1 (2.5) .xxx ± .020 (.51) .xx ± .02 (.5) ANGLES ±					
4	01.06.15	BDK	MPH	JADE	UPDATED TITLE BORDER AND UPDATED NOTES	SS-26888	THIRD ANGLE PROJECTION				SS-26888	
							DRAWN BY: RAM	DATE: 2-1-94	CHK: HVP	SCALE: NONE	SHT 1 OF 1	SIZE: A

D10100DA/16