

Installation Instructions

Original Instructions



Allen-Bradley

by ROCKWELL AUTOMATION

ControlLogix Chassis

Catalog Numbers 1756-A4, 1756-A4K, 1756-A7, 1756-A7K, 1756-A10, 1756-A10K, 1756-A13, 1756-A13K, 1756-A17, 1756-A17K, 1756-A7XT, 1756-A10XT

Topic	Page
Summary of Changes	1
Product Advisories	3
Tools Required	5
Parts Required	5
Chassis Mounting System Spacing Requirements	6
Mounting Dimensions	8
Install the Chassis	11
Ground the Chassis	12
Specifications	15
Additional Resources	15

Product Overview

The ControlLogix[®] system is a modular system that requires a 1756 ControlLogix chassis. The chassis are designed for only horizontal back-panel mounting. Place any module into any slot. The backplane provides a high-speed communication path between modules.

Summary of Changes

This publication contains the following new or updated information. This list includes substantive updates only and isn't intended to reflect all changes.

Topic	Page
Updated Special Conditions for Safe Use	4
Corrected cabinet clearance under Chassis Mounting System Spacing Requirements	6, 7



ATTENTION: Read this document and the documents listed in the Additional Resources section about installation, configuration and operation of this equipment before you install, configure, operate or maintain this product. Users are required to familiarize themselves with installation and wiring instructions in addition to requirements of all applicable codes, laws, and standards.

Activities including installation, adjustments, putting into service, use, assembly, disassembly, and maintenance are required to be carried out by suitably trained personnel in accordance with applicable code of practice. If this equipment is used in a manner not specified by the manufacturer, the protection provided by the equipment may be impaired.

注意：在安装、配置、操作和维护本产品前，请阅读本文档以及“其他资源”部分列出的有关设备安装、配置和操作的相应文档。除了所有适用规范、法律和标准的相关要求之外，用户还必须熟悉安装和接线说明。

安装、调整、投运、使用、组装、拆卸和维护等各项操作必须由经过适当训练的专业人员按照适用的操作规范实施。

如果未按照制造商指定的方式使用该设备，则可能会损害设备提供的保护。

ATENCIÓN: Antes de instalar, configurar, poner en funcionamiento o realizar el mantenimiento de este producto, lea este documento y los documentos listados en la sección Recursos adicionales acerca de la instalación, configuración y operación de este equipo. Los usuarios deben familiarizarse con las instrucciones de instalación y cableado y con los requisitos de todos los códigos, leyes y estándares vigentes.

El personal debidamente capacitado debe realizar las actividades relacionadas a la instalación, ajustes, puesta en servicio, uso, ensamblaje, desensamblaje y mantenimiento de conformidad con el código de práctica aplicable. Si este equipo se usa de una manera no especificada por el fabricante, la protección provista por el equipo puede resultar afectada.

ATENÇÃO: Leia este e os demais documentos sobre instalação, configuração e operação do equipamento que estão na seção Recursos adicionais antes de instalar, configurar, operar ou manter este produto. Os usuários devem se familiarizar com as instruções de instalação e fiação além das especificações para todos os códigos, leis e normas aplicáveis.

É necessário que as atividades, incluindo instalação, ajustes, colocação em serviço, utilização, montagem, desmontagem e manutenção sejam realizadas por pessoal qualificado e especializado, de acordo com o código de prática aplicável.

Caso este equipamento seja utilizado de maneira não estabelecida pelo fabricante, a proteção fornecida pelo equipamento pode ficar prejudicada.

ВНИМАНИЕ: Перед тем как устанавливать, настраивать, эксплуатировать или обслуживать данное оборудование, прочитайте этот документ и документы, перечисленные в разделе «Дополнительные ресурсы». В этих документах изложены сведения об установке, настройке и эксплуатации данного оборудования. Пользователи обязаны ознакомиться с инструкциями по установке и прокладке соединений, а также с требованиями всех применимых норм, законов и стандартов.

Все действия, включая установку, наладку, ввод в эксплуатацию, использование, сборку, разборку и техническое обслуживание, должны выполняться обученным персоналом в соответствии с применимыми нормами и правилами.

Если оборудование используется не предусмотренным производителем образом, защита оборудования может быть нарушена.

注意：本製品を設置、構成、稼働または保守する前に、本書および本機器の設置、設定、操作についての参考資料の該当箇所に記載されている文書に目を通してください。ユーザは、すべての該当する条例、法律、規格の要件に加えて、設置および配線の手順に習熟している必要があります。

設置調整、運転の開始、使用、組立て、解体、保守を含む諸作業は、該当する実施規則に従って訓練を受けた適切な作業員が実行する必要があります。

本機器が製造メーカーにより指定されていない方法で使用されている場合、機器により提供されている保護が損なわれる恐れがあります。

ACHTUNG: Lesen Sie dieses Dokument und die im Abschnitt „Weitere Informationen“ aufgeführten Dokumente, die Informationen zu Installation, Konfiguration und Bedienung dieses Produkts enthalten, bevor Sie dieses Produkt installieren, konfigurieren, bedienen oder warten. Anwender müssen sich neben den Bestimmungen aller anwendbaren Vorschriften, Gesetze und Normen zusätzlich mit den Installations- und Verdrahtungsanweisungen vertraut machen.

Arbeiten im Rahmen der Installation, Anpassung, Inbetriebnahme, Verwendung, Montage, Demontage oder Instandhaltung dürfen nur durch ausreichend geschulte Mitarbeiter und in Übereinstimmung mit den anwendbaren Ausführungsvorschriften vorgenommen werden.

Wenn das Gerät in einer Weise verwendet wird, die vom Hersteller nicht vorgesehen ist, kann die Schutzfunktion beeinträchtigt sein.

ATTENTION : Lisez ce document et les documents listés dans la section Ressources complémentaires relatifs à l'installation, la configuration et le fonctionnement de cet équipement avant d'installer, configurer, utiliser ou entretenir ce produit. Les utilisateurs doivent se familiariser avec les instructions d'installation et de câblage en plus des exigences relatives aux codes, lois et normes en vigueur.

Les activités relatives à l'installation, le réglage, la mise en service, l'utilisation, l'assemblage, le démontage et l'entretien doivent être réalisées par des personnes formées selon le code de pratique en vigueur.

Si cet équipement est utilisé d'une façon qui n'a pas été définie par le fabricant, la protection fournie par l'équipement peut être compromise.

주의：본 제품 설치, 설정, 작동 또는 유지 보수하기 전에 본 문서를 포함하여 설치, 설정 및 작동에 관한 참고 자료 섹션의 문서들을 반드시 읽고 숙지하십시오. 사용자는 모든 관련 규정, 법규 및 표준에서 요구하는 사항에 대해 반드시 설치 및 배선 지침을 숙지해야 합니다.

설치, 조정, 가동, 사용, 조립, 분해, 유지보수 등 모든 작업은 관련 규정에 따라 적절한 교육을 받은 사용자를 통해서만 수행해야 합니다.

본 장비를 제조사가 명시하지 않은 방법으로 사용하면 장비의 보호 기능이 손상될 수 있습니다.

ATTENZIONE: Prima di installare, configurare ed utilizzare il prodotto, o effettuare interventi di manutenzione su di esso, leggere il presente documento ed i documenti elencati nella sezione "Altre risorse", riguardanti l'installazione, la configurazione ed il funzionamento dell'apparecchiatura. Gli utenti devono leggere e comprendere le istruzioni di installazione e cablaggio, oltre ai requisiti previsti dalle leggi, codici e standard applicabili.

Le attività come installazione, regolazioni, utilizzo, assemblaggio, disassemblaggio e manutenzione devono essere svolte da personale adeguatamente addestrato, nel rispetto delle procedure previste.

Qualora l'apparecchio venga utilizzato con modalità diverse da quanto previsto dal produttore, la sua funzione di protezione potrebbe venire compromessa.

DİKKAT: Bu ürünün kurulumu, yapılandırılması, işletilmesi veya bakımı öncesinde bu dokümanı ve bu ekipmanın kurulumu, yapılandırılması ve işletimi ile ilgili ilave Kaynaklar bölümünde yer listelenmiş dokümanları okuyun. Kullanıcılar yürürlükteki tüm yönetmelikler, yasalar ve standartların gereksinimlerine ek olarak kurulum ve kablolarla talimatlarını da öğrenmek zorundadır. Kurulum, ayarlama, hizmete alma, kullanma, parçaları birleştirme, parçaları sökme ve bakım gibi aktiviteler sadece uygun eğitimleri almış kişiler tarafından yürürlükteki uygulamaya yönetmeliklerine uygun şekilde yapılabilir.

Bu ekipman üretici tarafından belirlenmiş amacın dışında kullanılırsa, ekipman tarafından sağlanan koruma bozulabilir.

注意事項：在安装、設定、操作或維護本產品前，請先閱讀此文件以及列於「其他資源」章節中有關安裝、設定與操作此設備的文件。使用者必須熟悉安裝和配線指示，並符合所有法規、法律和標準要求。

包括安裝、調整、交付使用、使用、組裝、拆卸和維護等動作都必須交由已經過適當訓練的人員進行，以符合適用的實作法規。

如果將設備用於非製造商指定的用途時，可能會造成設備所提供的保護功能受損。

POZOR: Než začnete instalovat, konfigurovat či provozovat tento výrobek nebo provádět jeho údržbu, přečtěte si tento dokument a dokumenty uvedené v části Dodatečné zdroje ohledně instalace, konfigurace a provozu tohoto zařízení. Uživatelé se musejí vedle požadavků všech relevantních vyhlášek, zákonů a norem nutně seznámit také s pokyny pro instalaci a elektrické zapojení.

Činnosti zahrnující instalaci, nastavení, uvedení do provozu, užívání, montáž, demontáž a údržbu musí vykonávat vhodné proškolený personál v souladu s příslušnými prováděcími předpisy. Pokud se toto zařízení používá způsobem neodpovídajícím specifikaci výrobce, může být narušena ochrana, kterou toto zařízení poskytuje.

UWAGA: Przed instalacją, konfiguracją, użytkowaniem lub konserwacją tego produktu należy przeczytać niniejszy dokument oraz wszystkie dokumenty wymienione w sekcji Dodatkowe źródła omawiające instalację, konfigurację i procedury użytkowania tego urządzenia. Użytkownicy mają obowiązek zapoznać się z instrukcjami dotyczącymi instalacji oraz oprzewodowania, jak również z obowiązującymi kodeksami, prawem i normami.

Działania obejmujące instalację, regulację, przekazanie do użytkowania, użytkowanie, montaż, demontaż oraz konserwację muszą być wykonywane przez odpowiednio przeszkolony personel zgodnie z obowiązującym kodeksem postępowania.

Jeśli urządzenie jest użytkowane w sposób inny niż określony przez producenta, zabezpieczenie zapewniane przez urządzenie może zostać ograniczone.

OBST! Läs detta dokument samt dokumentet, som står listat i avsnittet Övriga resurser, om installation, konfigurering och drift av denna utrustning innan du installerar, konfigurerar eller börjar använda eller utföra underhållsarbete på produkten. Användare måste bekanta sig med instruktioner för installation och kabeldragning, förutom krav enligt gällande koder, lagar och standarder.

Åtgärder som installation, justering, service, användning, montering, demontering och underhållsarbete måste utföras av personal med lämplig utbildning enligt lämpligt bruk.

Om denna utrustning används på ett sätt som inte anges av tillverkaren kan det hända att utrustningens skyddsanordningar försätts ur funktion.



LET OP: Lees dit document en de documenten die genoemd worden in de paragraaf Aanvullende informatie over de installatie, configuratie en bediening van deze apparatuur voordat u dit product installeert, configureert, bedient of onderhoudt. Gebruikers moeten zich vertrouwd maken met de installatie en de bedravingsinstructies, naast de vereisten van alle toepasselijke regels, wetten en normen.

Activiteiten zoals het installeren, afstellen, in gebruik stellen, gebruiken, monteren, demonteren en het uitvoeren van onderhoud mogen uitsluitend worden uitgevoerd door hiervoor opgeleide personeel en in overeenstemming met de geldende praktijkregels.

Indien de apparatuur wordt gebruikt op een wijze die niet is gespecificeerd door de fabrikant, dan bestaat het gevaar dat de beveiliging van de apparatuur niet goed werkt.

Product Advisories

North American Hazardous Location Approval

The following information applies when operating this equipment in hazardous locations.	Informations sur l'utilisation de cet équipement en environnements dangereux.
<p>Products marked "CL I, DIV 2, GP A, B, C, D" are suitable for use in Class I Division 2 Groups A, B, C, D, Hazardous Locations and nonhazardous locations only. Each product is supplied with markings on the rating nameplate indicating the hazardous location temperature code. When combining products within a system, the most adverse temperature code (lowest "T" number) may be used to help determine the overall temperature code of the system. Combinations of equipment in your system are subject to investigation by the local Authority Having Jurisdiction at the time of installation.</p>	<p>Les produits marqués "CL I, DIV 2, GP A, B, C, D" ne conviennent qu'à une utilisation en environnements de Classe I Division 2 Groupes A, B, C, D dangereux et non dangereux. Chaque produit est livré avec des marquages sur sa plaque d'identification qui indiquent le code de température pour les environnements dangereux. Lorsque plusieurs produits sont combinés dans un système, le code de température le plus défavorable (code de température le plus faible) peut être utilisé pour déterminer le code de température global du système. Les combinaisons d'équipements dans le système sont sujettes à inspection par les autorités locales qualifiées au moment de l'installation.</p>
 <p>WARNING: Explosion Hazard –</p> <ul style="list-style-type: none"> Do not disconnect equipment unless power has been removed or the area is known to be nonhazardous. Do not disconnect connections to this equipment unless power has been removed or the area is known to be nonhazardous. Secure any external connections that mate to this equipment by using screws, sliding latches, threaded connectors, or other means provided with this product. Substitution of components may impair suitability for Class I, Division 2. If this product contains batteries, they must only be changed in an area known to be nonhazardous. 	 <p>AVERTISSEMENT: Risque d'Explosion –</p> <ul style="list-style-type: none"> Couper le courant ou s'assurer que l'environnement est classé non dangereux avant de débrancher l'équipement. Couper le courant ou s'assurer que l'environnement est classé non dangereux avant de débrancher les connecteurs. Fixer tous les connecteurs externes reliés à cet équipement à l'aide de vis, loquets coulissants, connecteurs filetés ou autres moyens fournis avec ce produit. La substitution de composants peut rendre cet équipement inadapté à une utilisation en environnement de Classe I, Division 2. S'assurer que l'environnement est classé non dangereux avant de changer les piles.

Environment and Enclosure



ATTENTION:

This equipment is intended for use in a Pollution Degree 2 industrial environment, in overvoltage Category II applications (as defined in IEC 60664-1), at altitudes up to 2000 m (6562 ft) without derating.

This equipment isn't intended for use in residential environments and may not provide adequate protection to radio communication services in such environments.

This equipment is supplied as open-type equipment for indoor use. It must be mounted within an enclosure that is suitably designed for those specific environmental conditions that will be present and appropriately designed to help prevent personal injury resulting from accessibility to live parts. The enclosure must have suitable flame-retardant properties to help prevent or minimize the spread of flame, complying with a flame spread rating of 5VA or be approved for the application if nonmetallic. The interior of the enclosure must be accessible only by the use of a tool. Subsequent sections of this publication may contain additional information regarding specific enclosure type ratings required to comply with certain product safety certifications.

In addition to this publication, see the following:

- Industrial Automation Wiring and Grounding Guidelines, publication [1770-4.1](#), for additional installation requirements.
- NEMA Standard 250 and EN/IEC 60529, as applicable, for explanations of the degrees of protection provided by enclosures.

UK and European Hazardous Location Approval

The following applies to products marked , II 3 G. Such modules:

- Are Equipment Group II, Equipment Category 3, and comply with the Essential Health and Safety Requirements relating to the design and construction of such equipment given in Annex II to EU Directive 2014/34/EU and Schedule 1 of the UKEX Regulation 2016 No. 1107. See the UKEX and EU Declaration of Conformity at [rok.auto/certifications](#) for details.
- The type of protection is <Ex ec IIC T4 Gc> Equipment protection by increased safety "e".
- Equipment protection by increased safety "e", reference certificate number UL 22 ATEX 2734X and UL22UKEX2451X.
- Are intended for use in areas in which explosive atmospheres caused by gases, vapors, mists, or air are unlikely to occur, or are likely to occur only infrequently and for short periods. Such locations correspond to Zone 2 classification according to UKEX Regulation 2016 No. 1107 and ATEX directive 2014/34/EU.

IEC Hazardous Location Approval

The following applies to products with IECEx certification:

- Such products are intended for use in areas in which explosive atmospheres caused by gases, vapors, mists, or air are unlikely to occur, or are likely to occur only infrequently and for short periods. Such locations correspond to Zone 2 classification.
- The type of protection is <Ex ec IIC T4 Gc>.
- IECEx certificate number IECEx UL 22.0025X.

Prevent Electrostatic Discharge



ATTENTION: This equipment is sensitive to electrostatic discharge, which can cause internal damage and affect normal operation. Follow these guidelines when you handle this equipment:

- Touch a grounded object to discharge potential static.
 - Wear an approved grounding wriststrap.
 - Do not touch connectors or pins on component boards.
 - Do not touch circuit components inside the equipment.
 - Use a static-safe workstation, if available.
 - Store the equipment in appropriate static-safe packaging when not in use.
-

Special Conditions for Safe Use



WARNING:

- This equipment is not resistant to sunlight or other sources of UV radiation.
 - This equipment shall be mounted in a UKEX/ATEX/IECEx Zone 2 certified enclosure with a minimum ingress protection rating of at least IP54 (in accordance with EN/IEC 60079-0) and used in an environment of not more than Pollution Degree 2 (as defined in EN/IEC 60664-1) when applied in Zone 2 environments. The enclosure must be accessible only by the use of a tool.
 - This equipment shall be used within its specified ratings defined by Rockwell Automation.
 - Provision shall be made to prevent the rated voltage from being exceeded by transient disturbances of more than 140% of the peak rated voltage when applied in Zone 2 environments.
 - The instructions in the user manual shall be observed.
 - Secure any external connections that mate to this equipment by using screws, sliding latches, threaded connectors, or other means provided with this product.
 - Do not disconnect equipment unless power has been removed or the area is known to be nonhazardous.
-



ATTENTION:

- If this equipment is used in a manner that is not specified by the manufacturer, the protection that is provided by the equipment may be impaired.
 - Installation, adjustments, putting into service, use, assembly, disassembly, and maintenance shall be carried out by suitably trained personnel in accordance with an applicable code of practice. In case of malfunction or damage, no attempts at repair should be made. The module should be returned to the manufacturer for repair. Do not dismantle the module.
 - This equipment is certified for use only within the surrounding air temperature range of -25...+60 °C (-13...+140 °F) for non-XT ControlLogix chassis.
 - The 1756-A7XT and 1756-A10XT chassis are certified for use only within the surrounding air temperature range of -25...+70 °C (-13...+158 °F). The equipment must not be used outside of this range.
 - Use only a soft dry cloth to wipe down equipment. Do not use any cleaning agents.
-

Tools Required

When installing your chassis and power supplies, the following items are required:

- 3.18 mm (0.125 in.) slotted screwdriver
- 6.35 mm (0.25 in.) slotted or #2 Phillips screwdriver
- Torque screwdriver
- 11/32" socket
- Needle-nose pliers
- Crimper
- Wire stripper
- Drill

Parts Required

These parts aren't included with the chassis and must be ordered separately.

Parts Required Per Mounting Tab

Tab Position	With SEM Screws ⁽¹⁾	Without SEM Screws
Top	1 Phillips screw 1 flat washer 1 split-lock washer	N/A
Bottom	1 SEM screw	1 Phillips screw 1 star washer

(1) Phillips screw with attached star washer.

Total Parts Required Per Chassis

Chassis	Number of Mounting Tabs	With SEM Screws	Without SEM Screws
1756-A4, 1756-A4K, 1756-A7, 1756-A7K	2 top 2 bottom	<ul style="list-style-type: none"> • 2 Phillips screws • 2 flat washers • 2 split-lock washers • 2 SEM screws 	<ul style="list-style-type: none"> • 4 Phillips screws • 2 flat washers • 2 split-lock washers • 2 star washers
1756-A10, 1756-A10K, 1756-A7XT,	3 top 3 bottom	<ul style="list-style-type: none"> • 3 Phillips screws • 3 flat washers • 3 split-lock washers • 3 SEM screws 	<ul style="list-style-type: none"> • 6 Phillips screws • 3 flat washers • 3 split-lock washers • 3 star washers
1756-A10XT, 1756-A13, 1756-A13K	4 top 4 bottom	<ul style="list-style-type: none"> • 4 Phillips screws • 4 flat washers • 4 split-lock washers • 4 SEM screws 	<ul style="list-style-type: none"> • 8 Phillips screws • 4 flat washers • 4 split-lock washers • 4 star washers
1756-A17, 1756-A17K	5 top 5 bottom	<ul style="list-style-type: none"> • 5 Phillips screws • 5 flat washers • 5 split-lock washers • 5 SEM screws 	<ul style="list-style-type: none"> • 10 Phillips screws • 5 flat washers • 5 split-lock washers • 5 star washers

Chassis Mounting System Spacing Requirements

Spacing Requirements for a System with a Non-redundant Power Supply

Dimensions are in cm (in.).

IMPORTANT Make sure that you meet the minimum spacing requirements specified.
 Allow 15.3 cm (6.0 in.) between a cabinet, another chassis, or other heat source and the top or bottom of a chassis.
 Allow 5.1 cm (2.0 in.) between a wireway and the top or bottom of a chassis.
 Chassis are intended to be mounted only horizontally. Do not mount vertically.

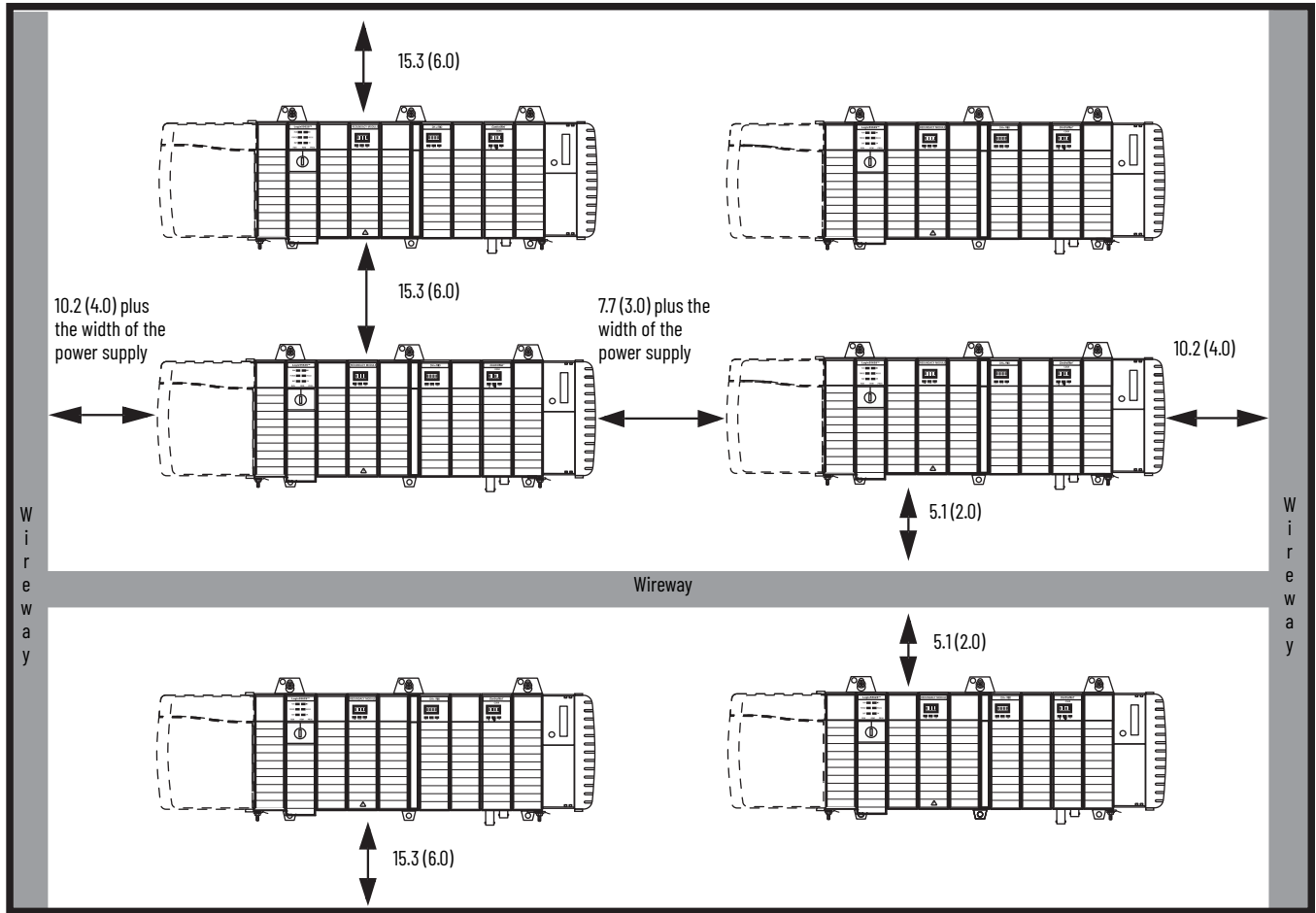

Spacing Requirements for a System with Redundant Power Supplies

Dimensions are in cm (in.).

IMPORTANT Make sure that you meet the minimum spacing requirements specified. Chassis and redundant power supplies are intended to be mounted only horizontally. Do not mount vertically. The 1756-CPR2 cable has a bend radius of 12.7 cm (5.0 in.). The chassis must have a minimum clearance of 12.7 cm (5.0 in.) on the left side to route and connect the 1756-CPR2 cable. The redundant power supplies must have a minimum clearance of 12.7 cm (5.0 in.) below the supply to route and connect the 1756-CPR2 cable. The 1756-CPR2D and 1756-CPR2U cables have right-angle connectors. The chassis must have a minimum clearance of 10.16 cm (4.0 in.) on the left side to route and connect the 1756-CPR2D and 1756-CPR2U cables.

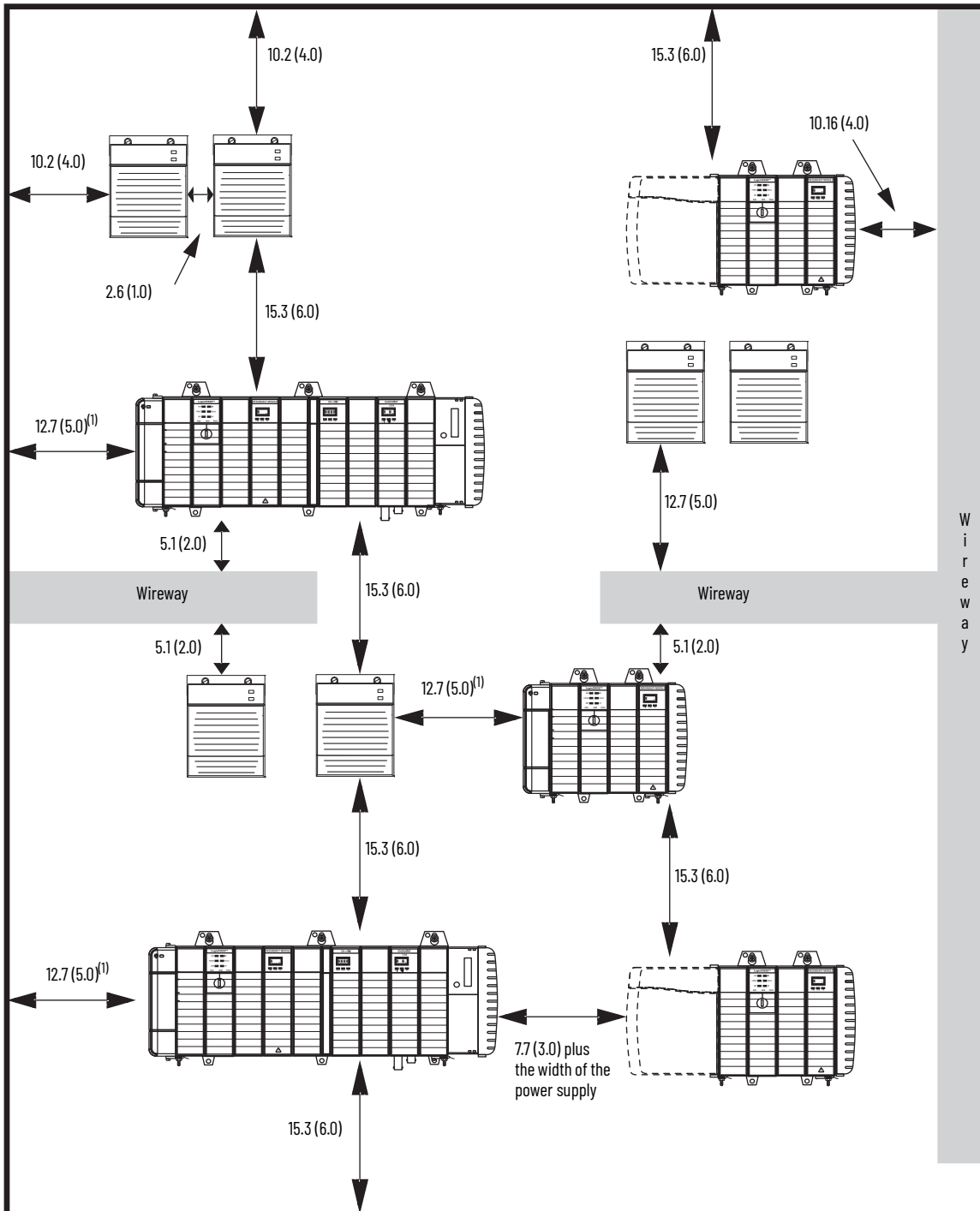

(1) The measurements for systems that use 1756-CPR2D or 1756-CPR2U cables are 10.2 cm (4.0 in.).

Mounting Dimensions

Dimensions are in cm (in.).

Chassis Common Dimensions

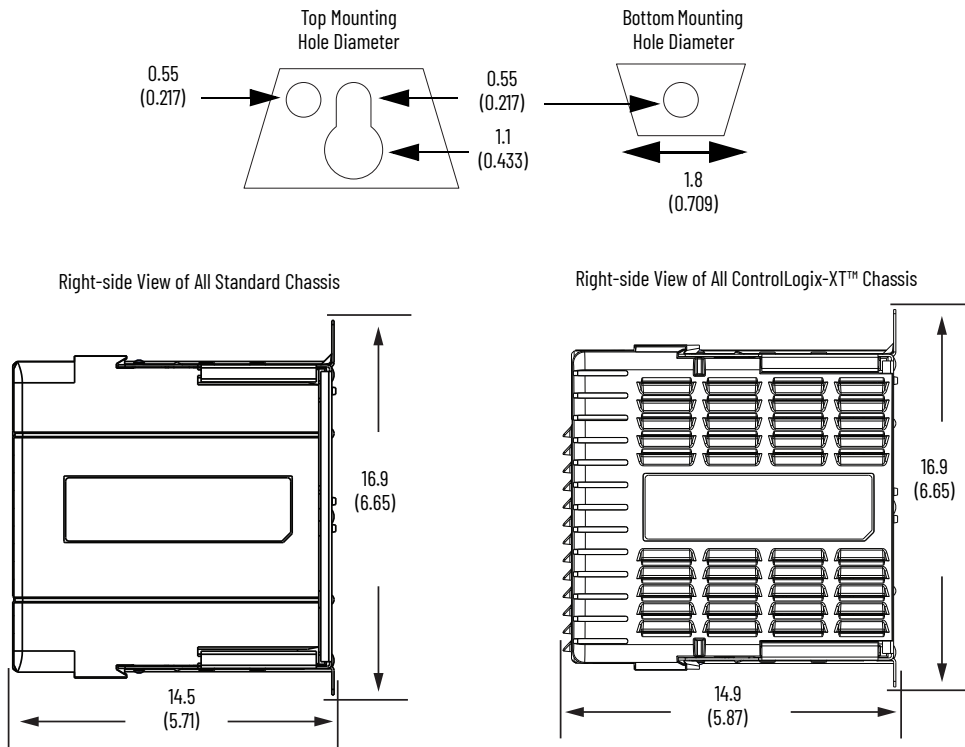

Standard refers to a standard power supply, and slim refers to a reduced-width power supply.

1756-A4 Chassis and Power Supply

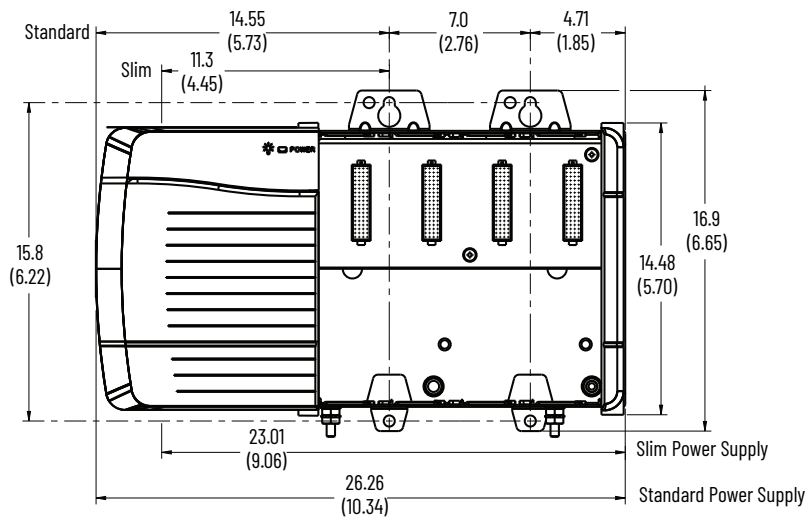

1756-A7 Chassis and Power Supply

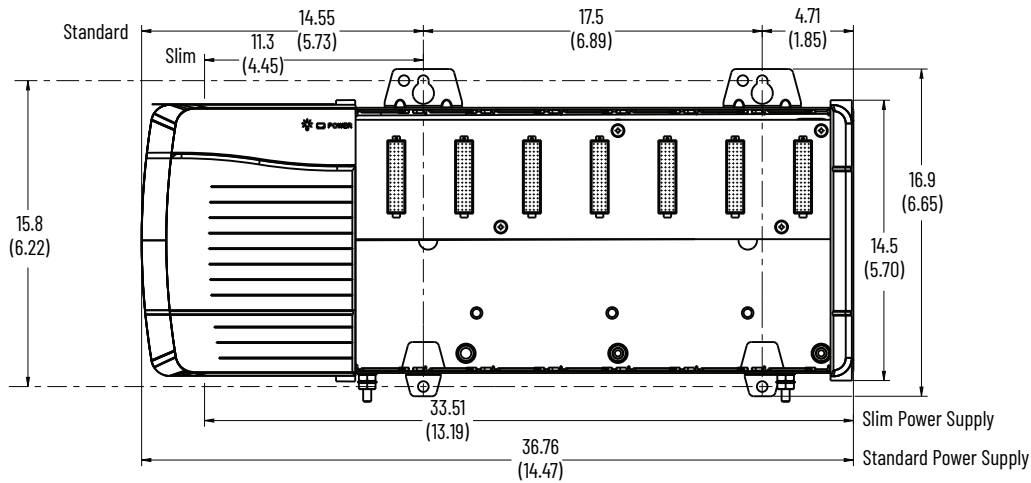

1756-A10 Chassis and Power Supply

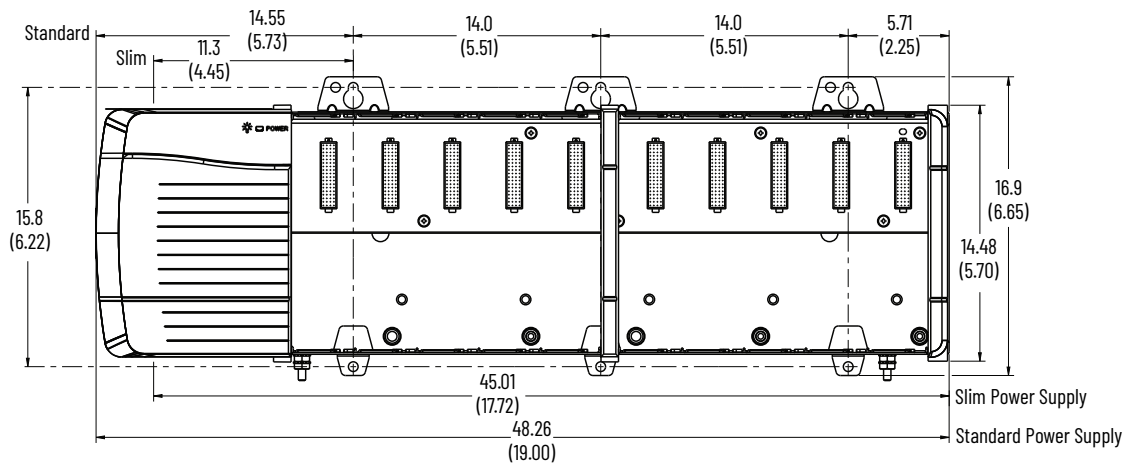

1756-A13 Chassis and Power Supply

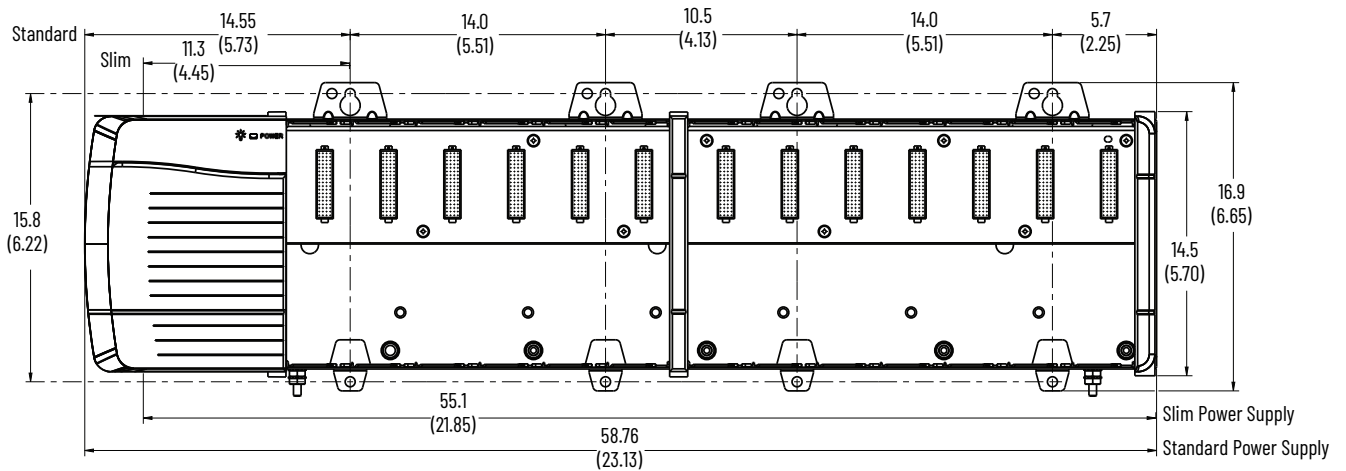

1756-A17 Chassis and Power Supply

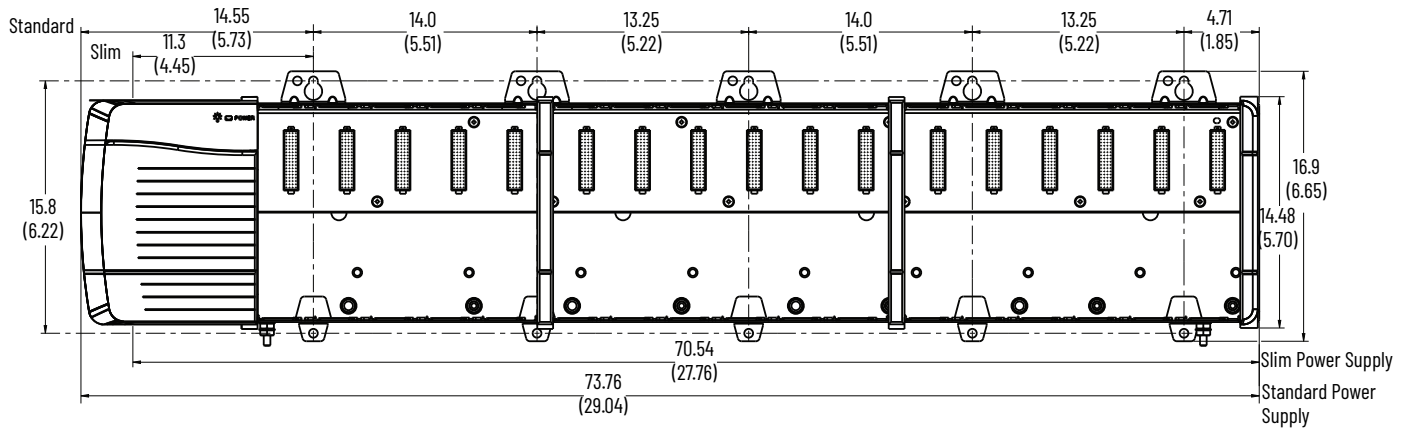

1756-A7XT Chassis and Power Supply

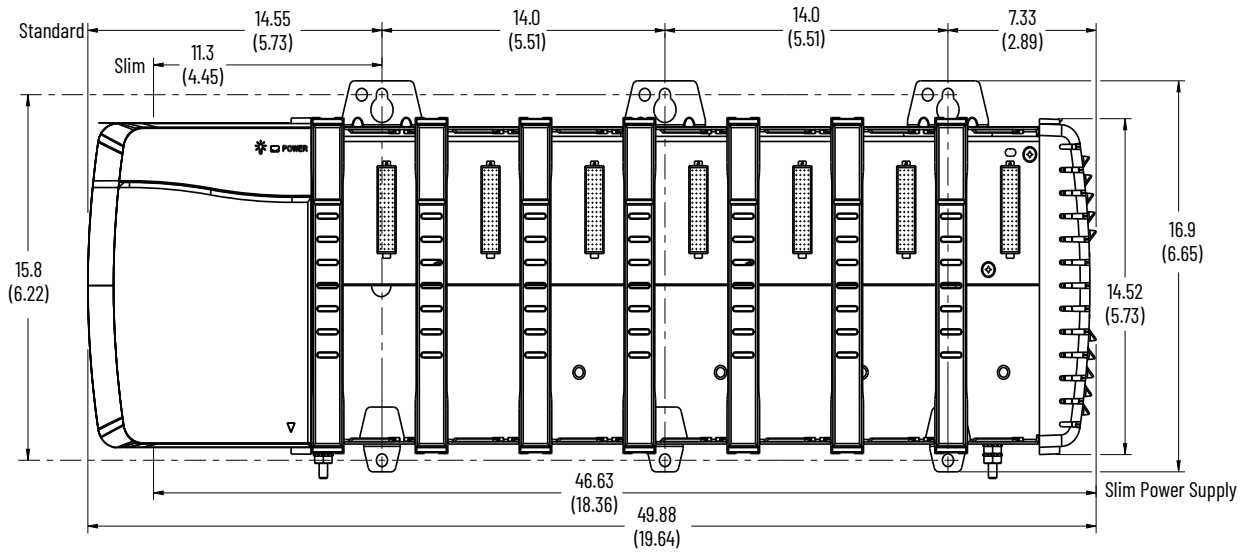

1756-A10XT Chassis and Power Supply

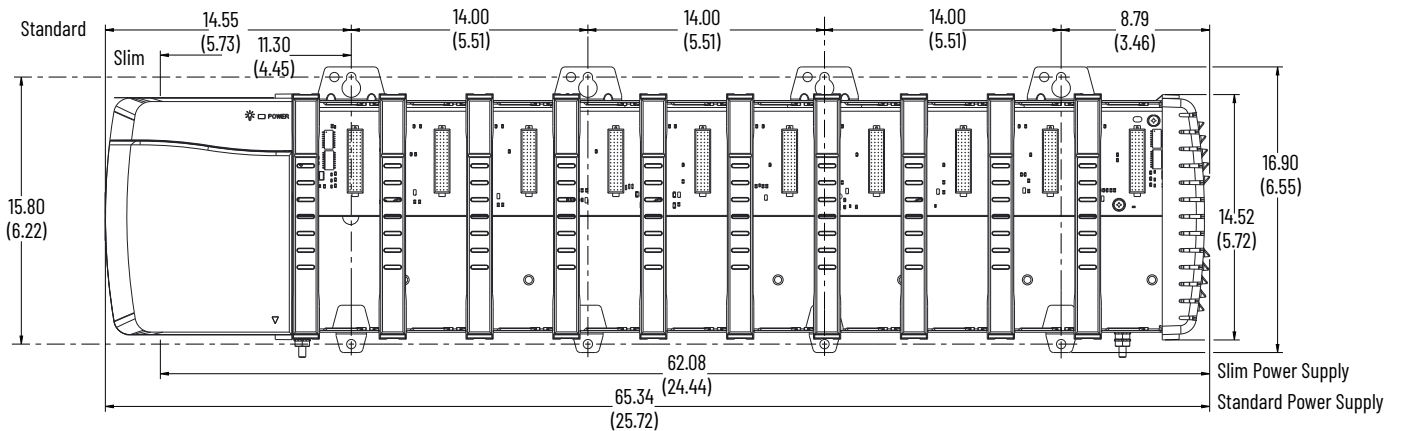

Install the Chassis

After planning your system, use these instructions to install the chassis.



ATTENTION: Do not drill holes above an installed chassis. Metal chips from drilling can damage the backplane and cause intermittent operation.

IMPORTANT Chassis are intended to be mounted only horizontally. Do not mount vertically.

1. Drill holes in the back panel of the enclosure for the chassis mounting tabs.
2. Scrape paint off the back panel for an electrical connection between the chassis and back panel.
3. Hold the chassis in place against the holes.



ATTENTION: If the chassis mounting tabs do not lay flat before the screws are tightened, use additional washers as shims so the chassis isn't warped by tightening the screws.
Warping a chassis can damage the backplane and cause intermittent operation.

4. Install the hardware for the top mounting tabs and tighten. See [Parts Required on page 5](#) for more information.
5. Install the remaining tab screws, but leave the leftmost bottom tab open.

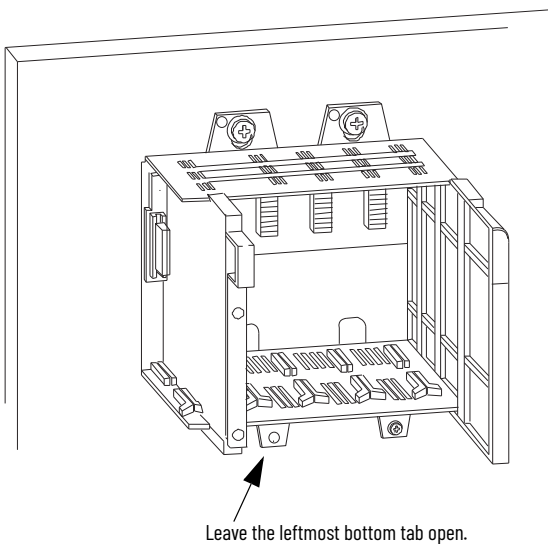

Ground the Chassis

This figure shows an example grounding configuration. After you complete the grounding steps, your system looks similar to this figure.



To minimize the resistance between the chassis and ground connection, keep wire lengths as short as possible.

Grounding Configuration Example

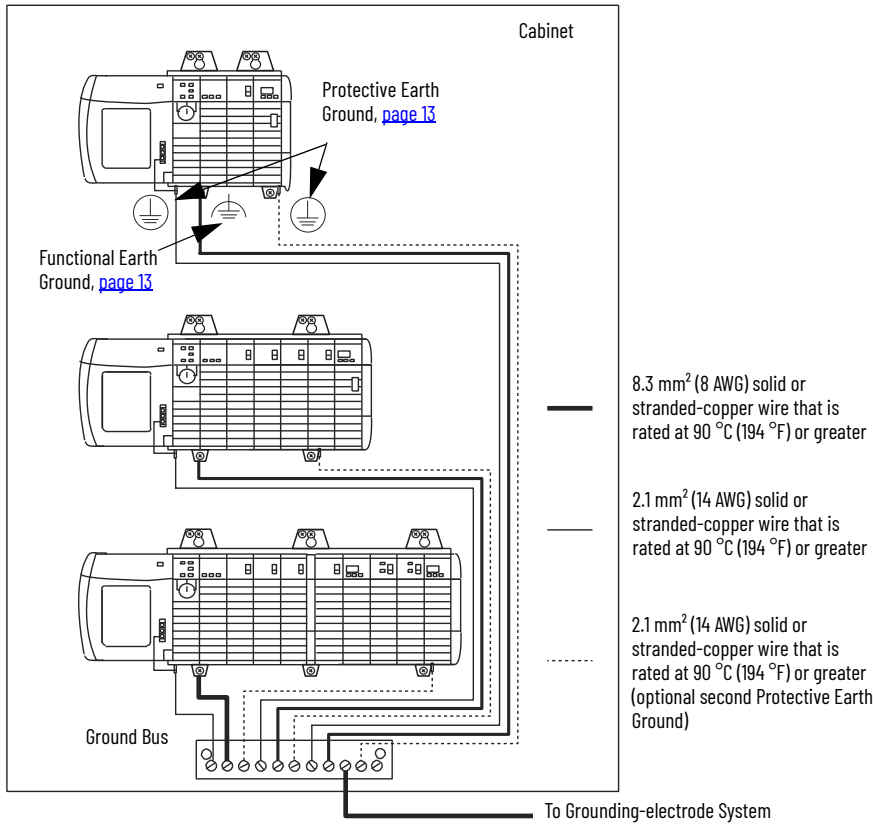

Use these guidelines when connecting the grounding:

- Use a steel enclosure to guard against electromagnetic interference (EMI).
- Install a bonding wire for electrical contact between the enclosure door and the enclosure; do not rely on the hinge.
- Make sure the enclosure-door viewing window is a laminated screen or a conductive optical substrate (to block EMI).

Install a Central Ground Bus

Each enclosure must contain a central ground bus. The ground bus is the common connection for each chassis within the enclosure and the enclosure itself. For more information on how to install a central ground bus, see the Industrial Automation Wiring and Grounding Guidelines, publication [1770-4.1](#).

Connect the Functional Earth Ground on the Chassis

Use 8.3 mm² (8 AWG) solid or stranded-copper wire that is rated at 90 °C (194 °F) or greater to connect the functional earth ground as shown in the following figure.

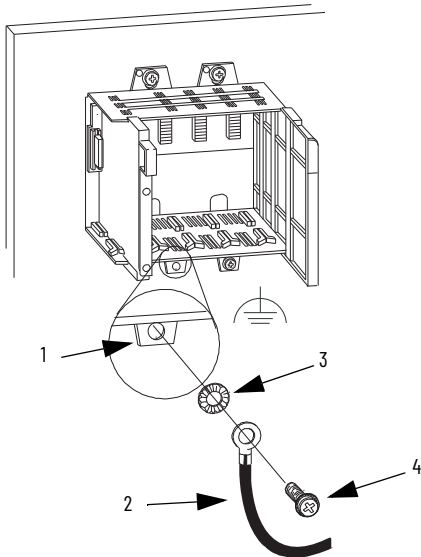

Item	Description
1	Chassis mounting tab
2	Equipment grounding conductor (ground lug with 8.3 mm ² [8 AWG] solid or stranded-copper wire that is rated at 90 °C [194 °F] or greater)
3	M4 or M5 (#10 or #12) flat or star washer
4	M4 or M5 (#10 or #12) Phillips screw and flat or star washer (or SEM screw)

Connect the Protective Earth Ground

Use 2.1 mm² (14 AWG) solid or stranded-copper wire that is rated at 90 °C (194 °F) or greater to connect the protective earth ground. Tighten the nuts on the protective earth ground terminal stud to a torque of 1.35 N•m (12 lb•in). Connect the functional earth ground as shown in this figure.

Protective Earth Ground Connection

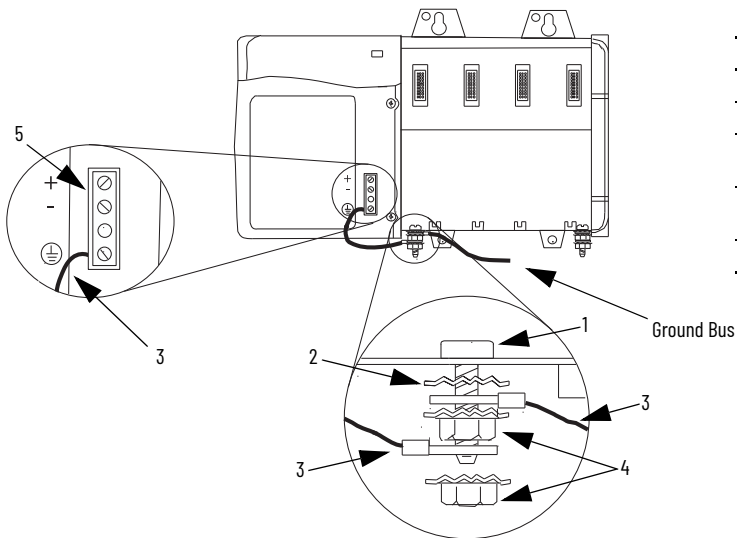

Item	Description
1	Protective earth ground terminal stud
2	Star washer
3	Equipment grounding conductor (ground lug with 2.1 mm ² [14 AWG] solid or stranded-copper wire that is rated at 90 °C [194 °F] or greater)
4	#8-32 x 11/32" nut with captive star washer Torque 1.35 N•m (12 lb•in)
5	Wiring terminal block (bottom terminal is protective earth ground)

IMPORTANT If your application requires a second protective earth ground connection, use the additional protective earth ground terminal stud to connect the chassis to the ground bus as shown in this figure.

Second Protective Earth Ground Connection

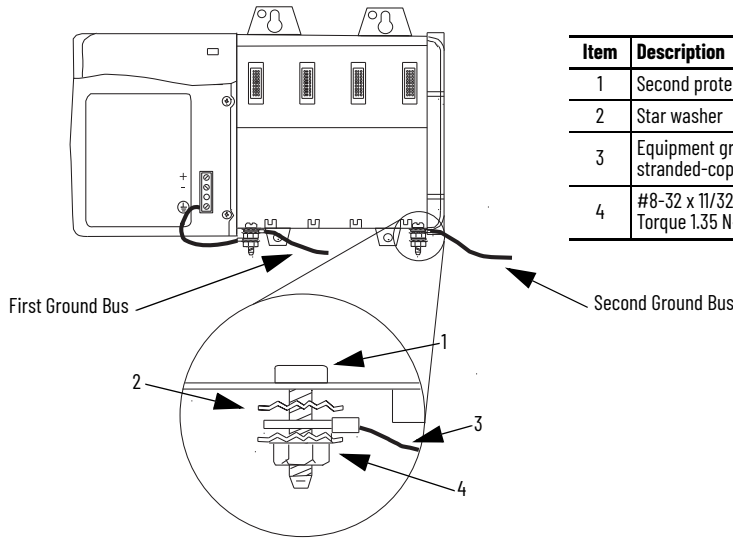

Item	Description
1	Second protective earth ground terminal stud
2	Star washer
3	Equipment grounding conductor (ground lug with 2.1 mm ² [14 AWG] solid or stranded-copper wire that is rated at 90 °C [194 °F] or greater)
4	#8-32 x 11/32" nut with captive star washer Torque 1.35 N•m (12 lb•in)

Connect the Grounding Conductors to the Ground Bus

Connect the equipment grounding conductors (functional and protective earth ground) directly from each chassis to an individual bolt on the ground bus.

Ground Bus Connection

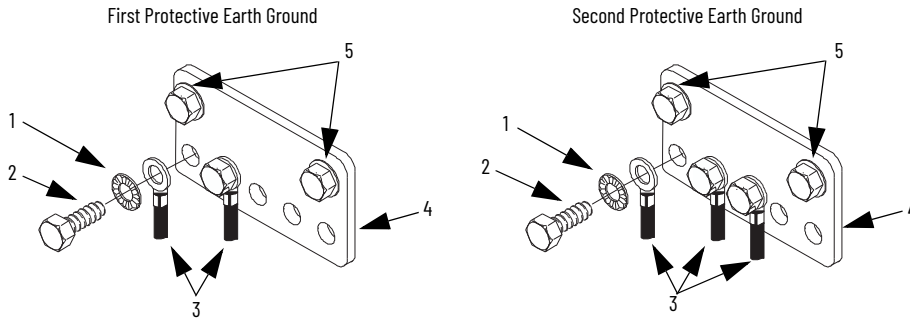

Item	Description
1	Flat or star washer
2	Bolt
3	Equipment grounding conductor (from protective and functional earth ground connections)
4	Ground bus
5	Ground bus mounting

Connect Ground Bus to Grounding-electrode System

Use a grounding-electrode conductor to connect the ground bus to the grounding-electrode system.

At minimum, use 8.3 mm² (8 AWG) solid or stranded-copper wire that is rated at 90 °C (194 °F) or greater for the grounding-electrode conductor to guard against EMI. The National Electrical Code specifies safety requirements for the grounding-electrode conductor.

Grounding-electrode System Connection

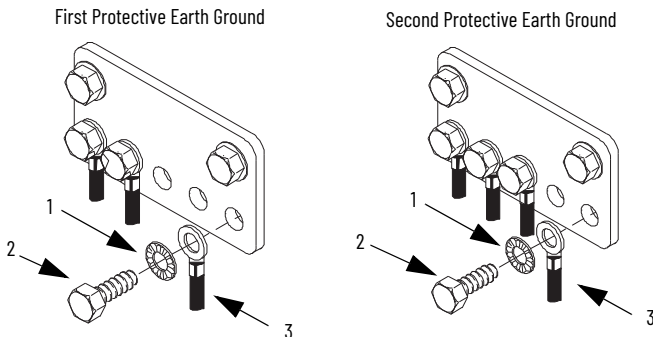

Item	Description
1	Flat or star washer
2	Bolt
3	Equipment grounding conductor (ground lug with minimum 8.3 mm ² [8 AWG] solid or stranded-copper wire that is rated at 90 °C [194 °F] or greater)

Specifications

Standard ControlLogix Chassis Specifications

Attribute	1756-A4, 1756-A4K	1756-A7, 1756-A7K	1756-A10, 1756-A10K	1756-A13, 1756-A13K	1756-A17, 1756-A17K
Backplane current, chassis/slot max @ 1.2V DC	1.5 A/-				
Backplane current, chassis/slot max @ 3.3V DC	4A/4A				
Backplane current, chassis/slot max @ 5.1V DC	15 A/6 A				
Backplane current, chassis/slot max @ 24V DC	2.8 A/2.8 A				
Isolation voltage	Determined by installed power supply and modules				
Temperature, operating IEC 60068-2-1 (Test Ad, Operating Cold), IEC 60068-2-2 (Test Bd, Operating Dry Heat), IEC 60068-2-14 (Test Nb, Operating Thermal Shock)	-25...+60 °C (-13...+140 °F)				
Temperature, surrounding air, max	60 °C (140 °F)				
Enclosure type rating	None (open-style)				
Slots	4	7	10	13	17
Wire size	Functional Earth Ground: 8.3 mm ² (8 AWG) solid or stranded copper wire that is rated at 90 °C (194 °F) or greater Protective Earth Ground: 2.1 mm ² (14 AWG) solid or stranded copper wire that is rated at 90 °C (194 °F) or greater				
North American temperature code	T4				
IECEx temperature code	T4				

ControlLogix-XT Chassis Specifications

Attribute	1756-A7XT	1756-A10XT
Backplane current, chassis/slot max @ 1.2V DC	1.5 A/-	
Backplane current, chassis/slot max @ 3.3V DC	4 A/4 A	
Backplane current, chassis/slot max @ 5.1V DC	15 A/6 A	
Backplane current, chassis/slot max @ 24V DC	2.8 A/2.8 A	
Isolation voltage	Determined by installed power supply and modules	
Temperature, operating IEC 60068-2-1 (Test Ad, Operating Cold), IEC 60068-2-2 (Test Bd, Operating Dry Heat), IEC 60068-2-14 (Test Nb, Operating Thermal Shock)	-25...+70 °C (-13...+158 °F)	
Temperature, surrounding air, max	70 °C (158 °F)	
Enclosure type rating	None (open-style)	
Slots	7	10
Wire size	Functional Earth Ground: 8.3 mm ² (8 AWG) solid or stranded copper wire that is rated at 90 °C (194 °F) or greater Protective Earth Ground: 2.1 mm ² (14 AWG) solid or stranded copper wire that is rated at 90 °C (194 °F) or greater	
North American temperature code	T4	
IECEx temperature code	T4	

Additional Resources

These documents contain additional information concerning related products from Rockwell Automation.

Resource	Description
ControlLogix Chassis Specifications Technical Data, publication 1756-TD006	Provides technical specifications for ControlLogix chassis.
ControlLogix Power Supplies Specifications Technical Data, publication 1756-TD005	Provides technical specifications for ControlLogix power supplies.
ControlLogix Power Supply Installation Instructions, publication 1756-IN619	Provides information on how to install ControlLogix standard power supplies.
ControlLogix Redundant Power Supply Installation Instructions, publication 1756-IN620	Provides information on how to install ControlLogix redundant power supplies.
ControlLogix System User Manual, publication 1756-UM001	Provides instructions for installation and use of ControlLogix Systems, application design, and other general information for these systems.
Industrial Automation Wiring and Grounding Guidelines, publication 1770-4.1	Provides general guidelines for installing a Rockwell Automation industrial system.
Product Certifications website, rok.auto/certifications	Provides declarations of conformity, certificates, and other certification details.

You can view or download publications at rok.auto/literature.

Rockwell Automation Support

Use these resources to access support information.

Technical Support Center	Find help with how-to videos, FAQs, chat, user forums, Knowledgebase, and product notification updates.	rok.auto/support
Local Technical Support Phone Numbers	Locate the telephone number for your country.	rok.auto/phonesupport
Technical Documentation Center	Quickly access and download technical specifications, installation instructions, and user manuals.	rok.auto/techdocs
Literature Library	Find installation instructions, manuals, brochures, and technical data publications.	rok.auto/literature
Product Compatibility and Download Center (PCDC)	Download firmware, associated files (such as AOP, EDS, and DTM), and access product release notes.	rok.auto/pcdc

Documentation Feedback

Your comments help us serve your documentation needs better. If you have any suggestions on how to improve our content, complete the form at rok.auto/docfeedback.

Waste Electrical and Electronic Equipment (WEEE)



At the end of life, this equipment should be collected separately from any unsorted municipal waste.

Rockwell Automation maintains current product environmental compliance information on its website at rok.auto/pec.

Rockwell Otomasyon Ticaret A.Ş. Kar Plaza İş Merkezi E Blok Kat:6 34752 İçerenköy, İstanbul, Tel: +90 (216) 5698400 EEE Yönetmeliğine Uygundur

Connect with us.    

rockwellautomation.com

expanding human possibility®

AMERICAS: Rockwell Automation, 1201 South Second Street, Milwaukee, WI 53204-2496 USA, Tel: (1) 414.382.2000, Fax: (1) 414.382.4444

EUROPE/MIDDLE EAST/AFRICA: Rockwell Automation NV, Pegasus Park, De Kleetlaan 12a, 1831 Diegem, Belgium, Tel: (32) 2 663 0600, Fax: (32) 2 663 0640

ASIA PACIFIC: Rockwell Automation, Level 14, Core F, Cyberport 3, 100 Cyberport Road, Hong Kong, Tel: (852) 2887 4788, Fax: (852) 2508 1846

UNITED KINGDOM: Rockwell Automation Ltd, Pitfield, Kiln Farm Milton Keynes, MK11 3DR, United Kingdom, Tel: (44)(1908) 838-800, Fax: (44)(1908) 261-917

Allen-Bradley, ControlLogix, ControlLogix-Xt, expanding human possibility, and Rockwell Automation are trademarks of Rockwell Automation, Inc. Trademarks not belonging to Rockwell Automation are property of their respective companies.