

Installation Instructions

Original Instructions



Allen-Bradley
by ROCKWELL AUTOMATION



SensaGuard Rectangular Flat Pack (Series B Models Only)

Catalog Number 440N-Z21x

IMPORTANT Save these instructions for future use.

| Topic | Page |
|---|------|
| Introduction | 1 |
| Specifications | 2 |
| Approximate Dimensions | 2 |
| Mode of Operation | 2 |
| Diagnostics | 3 |
| Installation | 3 |
| Typical Wiring | 3 |
| Commissioning the Unique Coded Actuator | 4 |
| OSSD Test Pulses | 5 |
| Timing Diagram | 5 |
| Troubleshooting | 6 |
| Application Wiring Examples | 7 |
| Recommended Safety Control Interfaces | 11 |
| Maintenance | 11 |
| Repair | 11 |
| Declaration of Conformity | 11 |
| Additional Resources | 11 |

Summary of Changes

This publication contains the following new or updated information. This list includes substantive updates only and is not intended to reflect all changes.

| Topic | Page |
|-----------------------------------|------|
| Updated Certifications | 2 |
| Updated Maintenance | 11 |
| Updated Declaration of Conformity | 11 |

Introduction

Installation must be in accordance with the following instructions and specifications and implemented by suitable competent personnel. Adherence to the recommended maintenance instructions forms part of the warranty.

Do not use this unit as a mechanical stop. You must fit guard stops and guides.

This device is intended to be part of the safety-related control system of a machine. Before installation, you must perform a risk assessment to determine whether the specifications of this device are suitable for all foreseeable operational and environmental characteristics.



WARNING: Do not defeat, tamper, remove, or bypass this unit. Severe injury to personnel can result.



ATTENTION: You must provide the device with a 24V DC PELV or SELV power supply that conforms to the requirements of 414-3 of IEC 60364-4-41 where provisions are taken. The voltage at the outgoing terminals cannot exceed 60V DC, even if there is an internal fault.

Improper selection or installation of the devices affects the integrity of the safety systems.

Personal injury or death, property damage, or economic loss can result.

Comply with ISO 14119 including section, accessibility to the installation, arrangement, and mounting, possible substitute actuation, access to the escape release, motivation to defeat, and actuation mode.

Use management controls, working procedures, training, and additional protective measures to minimize the motivation to defeat and to manage the use and availability of spare actuators.

Comply with ISO 13857 and ISO 13855 for guard openings and minimum (safe) distances.

Comply with EN ISO 13849-1, EN ISO 13849-2, and EN 61508 for machinery and functional safety.

SensaGuard™ Series A and Series B non-contact switches only work with the appropriate series actuator. Purchase Series A and Series B actuators separately.

This product is intended for industrial/business application only. This product is not intended for use in residential applications, as it can cause radio interference on other residential devices.



ATTENTION: Read this document and the documents that are listed in [Additional Resources on page 11](#) before you install. Familiarize yourself with the installation and connection instructions and requirements of all applicable codes, laws, and standards.

In accordance with applicable codes of practice, suitably trained personnel must implement installation, adjustments, service initiation, use, assembly, disassembly, and maintenance.

Use of this equipment not specified by the manufacturer can impair the protection that the equipment provides.



ATTENTION: Do not attempt to install this device unless the installation instructions have been studied and understood. This document acts as a guide for a typical installation and is available in additional languages at [rok.auto/literature](#).

Specifications

| Attribute | Value |
|--|---|
| Safety Ratings | |
| Standards safety classification | IEC 60947-5-3, Cat. 4 PLe Per ISO 13849-1, Type 4 interlocking device according to ISO 14119 with either low (standard) or high (unique) coding, SIL CL 3 per IEC 61508 |
| Functional safety data | PFH _d = 1.32E-9 (probability of dangerous failure per hr) T _I = 20 (proof test interval) |
| Certifications | CE Marked for all applicable EU directives. UKCA Marked for all applicable regulations, cULus Listed (UL 508), TÜV Certified rok.auto/certifications |
| Operating Characteristics | |
| Sensing distance [mm (in.)] | <ul style="list-style-type: none"> Assured on: 15 (0.59)⁽¹⁾ Assured off: 25 (0.98) |
| Operating voltage | 24V DC 10%/-15% Class 2 SELV or PELV power supply |
| Response time (off) | 45 ms |
| Utilization category | DC-12 and DC-13 U _e : 24V I _e : 200 mA |
| Frequency of operating cycle | 0.25 Hz |
| No-load supply current | < 50 mA |
| Outputs (OSSD) | |
| Safe state | De-energized (2 x PNP, 0V), AUX energized (1 x PNP, 24V) |
| Run state | Energized (2 x PNP, 24V), AUX de-energized (1 x PNP, 0V) |
| Load current | 200 mA, max |
| Voltage drop | < 1.5V |
| Switches connected in series | Unlimited (see Timing Diagram on page 5) |
| Mechanical | |
| Sensor/actuator case material | Polycarbonate |
| Environmental | |
| Operating temperature [C° (F°)] | -25...+70 (-13...+158) |
| Operating humidity | 5...95% relative |
| Washdown rating | IP66, IP67, IP69K |
| Shock and vibration | IEC 60068-2-27: 30 g, 11 ms IEC 60068-2-6: 10...55 Hz |
| Pollution degree | IEC 60947-1: 3 |
| Electromagnetic Compatibility (EMC) | |
| Electrostatic discharge ESD | IEC 61000-4-2: Air discharge Per IEC 61326-1 (functional): 8 kV Per IEC 61000-6-7 (fail-safe): 8 kV |
| Radiated EMF immunity | IEC 61000-4-3 Per IEC 61326-1 (functional): 10V/m Per IEC 61000-6-7 (fail-safe): 20V/m |
| Electrical fast transient/burst immunity | IEC 61000-4-4 Per IEC 61326-1 (functional): 2 kV/5 kHz Per IEC 61000-6-7 (fail-safe): 2 kV/5 kHz |
| Conducted immunity | IEC 61000-4-6 Per IEC 61326-1 (functional): 10V Per IEC 61000-6-7 (fail-safe): 20V |
| Rated impulse withstand voltage | IEC 60947-1: 1 kV |
| Protection | <ul style="list-style-type: none"> Short circuit Overload Reverse polarity Overvoltage Loss of ground |
| Physical Characteristics | |
| Torque settings, max [N·m (lb·in)] | Switch/actuator mounting nut: 2.20 (19.5) |

(1) 13 mm (0.51 in.) for -CU models.

Approximate Dimensions

Figure 1 - Actuator [mm (in.)]

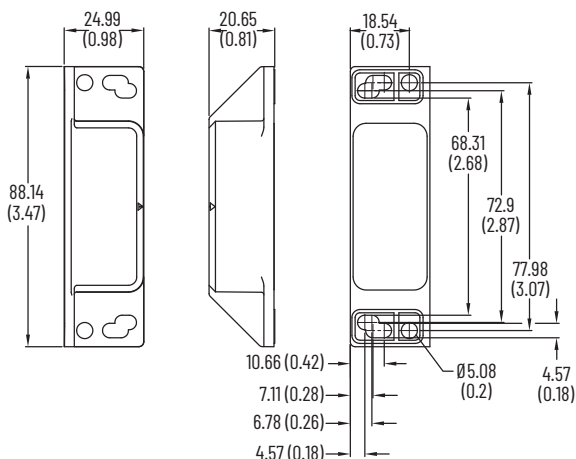
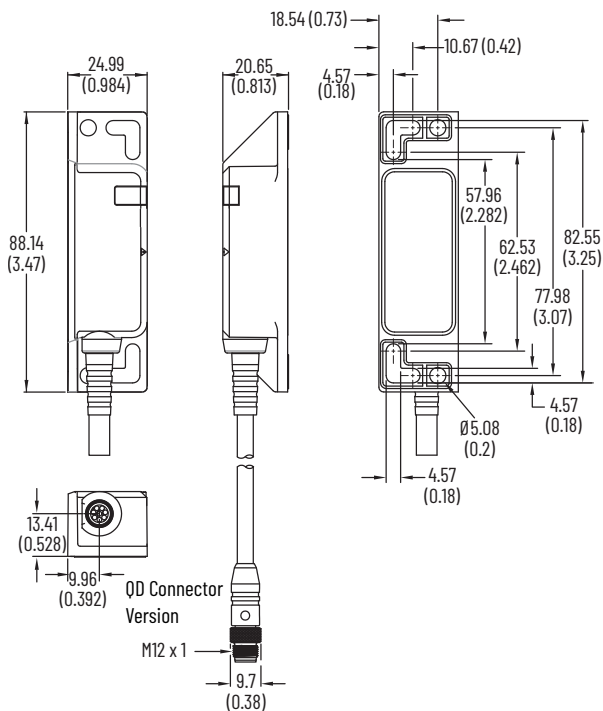
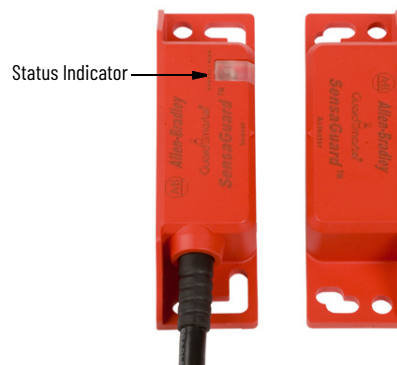

Figure 2 - Sensor Dimensions [mm (in.)]



Mode of Operation

Figure 3 - Status Indicator



The actuator is supplied with the sensor.

Diagnostics

Table 1 - Signal from Status/Diagnostic Indicator

| State | Status | Troubleshooting |
|-----------------|---|--|
| Off | Not powered | — |
| Red | OSSD not active | — |
| Green | OSSD active | — |
| Flashing green | Power up test or OSSD inputs not valid | Check 24V DC or OSSD inputs (yellow or red wire) |
| Flashing red | 0.5 Hz flash OSSD fault | OSSD fault. Check that OSSD outputs are not shorted to GND, 24V DC, or each other. |
| | 2 Hz flash internal fault | Cycle power. |
| Flashing yellow | Actuator is at the maximum sensing range (-N and -N9 models only) | Move the actuator closer to the sensor. |

See [Unique Coded Diagnostic on page 4](#) for learn sequence errors.

Installation

IMPORTANT Do not over torque the mounting hardware. See [Torque settings, max on page 2](#).

Use nonremovable screws, bolts, or nuts to mount the switch and actuator. Position the switch and actuator so they align with each other.

Figure 4 - Minimum Distance Between Sensors [mm (in.)]

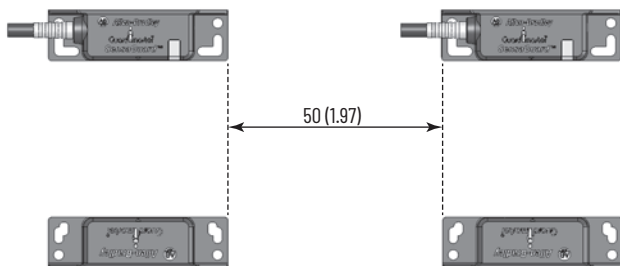
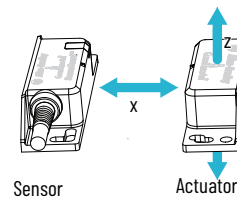
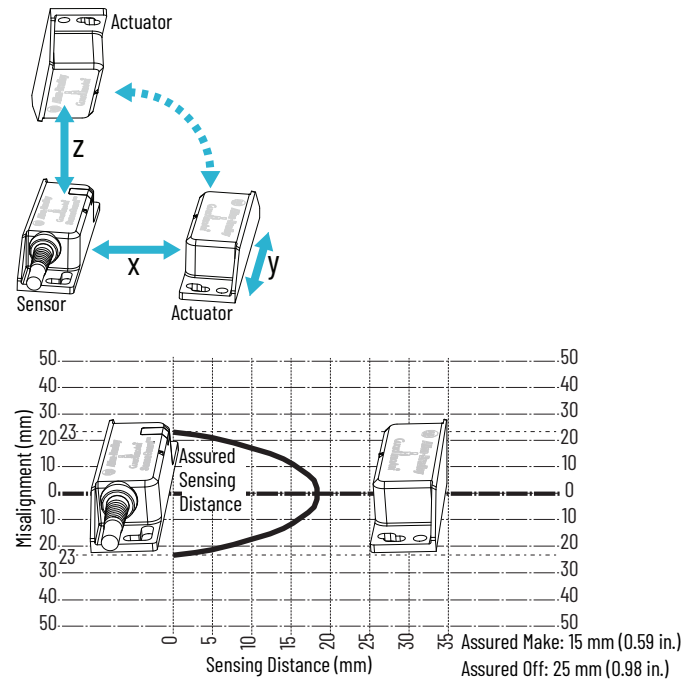
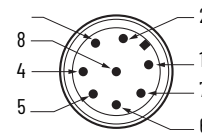

Figure 5 - Misalignment Curve



Typical Wiring

Table 2 - 8-pin Diagram



| Pin | Color | Signal |
|-----|--------|------------------|
| 1 | White | Auxiliary Output |
| 2 | Brown | 24V DC |
| 3 | Green | — |
| 4 | Yellow | OSSD 2 Input |
| 5 | Gray | OSSD 1 Output |
| 6 | Pink | OSSD 2 Output |
| 7 | Blue | 0V |
| 8 | Red | OSSD 1 Input |

The recommended cable connection is 2 m (6.5 ft) (catalog number 889D-F8AB-2). For additional lengths, replace the 2 with 5 (5 m [16.4 ft]) or 10 (10 m [32.8 ft]).

Table 3 - 5-pin Diagram



| Pin | Color | Signal |
|-----|-------|----------------------|
| 1 | Brown | +24V |
| 2 | White | Safety OSSD 1 Output |
| 3 | Blue | 0V |
| 4 | Black | Safety OSSD 2 Output |
| 5 | Gray | Auxiliary Output |

The recommended cordset is 2 m (6.5 ft) (catalog number 889D-F5AC-2). For additional lengths, replace the 2 with 5 (5 m [16 ft]) or 10 (10 m [32.8 ft]).

IMPORTANT If you do not require the auxiliary signal, use a 4-pin cordset (catalog number 889D-F4AC-2).

The recommended patchcord for use with the ArmorBlock® Guard I/O™ module is 2 m (6.5 ft) (catalog number 889D-F4ACDM-2). Replace the 2 with OM3 (0.3 m [0.98 ft]), 1 (1 m [3.28 ft]), 5 (5 m [16.4 ft]), or 10 (10 m [32.8 ft]) for standard cable lengths.

IMPORTANT Do not use a 5-pin patchcord with the ArmorBlock Guard I/O module.

Commissioning the Unique Coded Actuator

Power the Sensor

Connect the sensor to 24V DC (see [Typical Wiring on page 3](#)).

IMPORTANT The unique coded sensor ships from the factory unprogrammed and must be taught a unique coded actuator, see [Teach the Actuator](#).
 A unique coded sensor can only learn a unique coded actuator and cannot learn a standard coded actuator. A standard coded sensor does not work with a unique coded actuator.
 The unique coded sensor Status/Diagnostic indicator, flashes green eight times then repeats, which indicates that the sensor has not yet learned an actuator.
 You can lock the unique coded sensor so it cannot learn another actuator, see [Teach the Unique Actuator](#).

Teach the Actuator

(ability to learn an additional actuator)

Quick Start

1. Power up the sensor and bring an actuator into the sensing range.
2. Leave the actuator in the sensing field for a minimum of 2 minutes.
3. The learn process is complete.

IMPORTANT The sensor can learn a new actuator up to eight times. The Status/Diagnostic indicator flashes the number of actuators left that a sensor can learn.

Ability to Learn an Additional Actuator

The sensor automatically starts the learn process once an actuator enters the sensing range.

Table 4 - Learn Sequence

| Step | Description | |
|------|--------------------|---|
| 1 | Target present | Status/Diagnostic indicator flashes green 2 Hz rate (15 s) |
| 2 | Verifying actuator | Status/Diagnostic indicator flashes green/red 1 Hz rate (15 s) |
| 3 | Program sensor | Status/Diagnostic indicator flashes green/red 2 Hz rate (15 s) |
| 4 | Program complete | Status/Diagnostic indicator flashes green 2 Hz rate (number of learns that remain) (15 s) |
| 5 | Ready state | Status/Diagnostic indicator shows steady green |
| 6 | Learn is complete | - |

Teach the Unique Actuator

(one-time learn only; unit locked)

Initial Teach of the Actuator

The sensor automatically starts the learn process once an actuator enters the sensing range.

Table 5 - Learn Sequence

| Step | Description | |
|------|--|---|
| 1 | Target present | Status/Diagnostic indicator flashes green 2 Hz rate (15 s) |
| 2 | Verifying actuator | Status/Diagnostic indicator flashes green/red 1 Hz rate (15 s) |
| 3 | Program sensor | Status/Diagnostic indicator flashes green/red 2 Hz rate (15 s) |
| 4 | Program locking | Status/Diagnostic indicator flashing green 2 Hz rate (number of learns that remain) (15 s) |
| 5 | Remove the actuator from the sensing field | Status/Diagnostic indicator changes to steady red |
| 6 | Replace the actuator back into the sensing field | Status/Diagnostic indicator flashes green 2 Hz rate (number of learns that remain), this action triggers the lock function. |
| 7 | Ready state | Status/Diagnostic indicator shows steady green |
| 8 | Learn is complete | Sensor is locked and cannot learn another actuator. |

Learn a New Unique Coded Actuator

- To learn a replacement actuator, bring the actuator to be taught into the sensing range of the safety switch.
- The learn sequence is the same as the sequence for [Teach the Actuator](#).
- A sensor cannot relearn a previously learned actuator or a standard SensaGuard actuator.
- The sensor only recognizes the most recently learned actuator.

Unique Coded Diagnostic

Error codes for the learn process. Cycle power to clear the fault.

Table 6 - Signal from Status/Diagnostic Indicator

| Flashes (2 Hz) | Error Code |
|---|--|
| Green | OSSD inputs not valid. |
| Red-red-red-green | Cannot learn a standard SensaGuard actuator. |
| Red-red-red-green-green | Actuator already learned. |
| Red-red-red-green-green-green | Bad RFID. Target moved out of range. |
| Red-red-red-green-green-green-green | Exceeded learning eight actuators. |
| Red-red-red-green-green-green-green-green | Unit locked. Cannot learn another actuator. |

OSSD Test Pulses

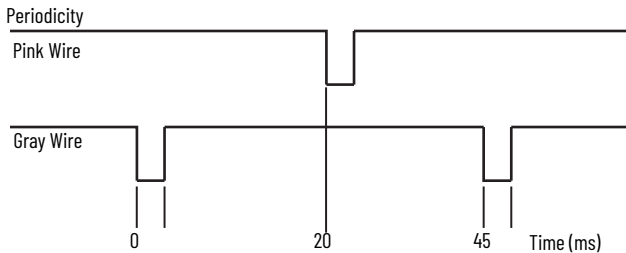
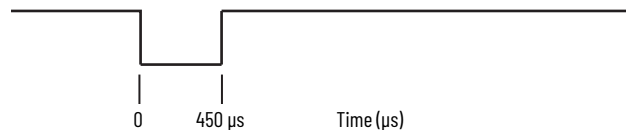

Individual Pulses

Test pulses appear on each OSSD output. These pulses are approximately every 45 ms. The times that are shown are approximate and depend on the processing of the safety-related status.

Timing Diagram

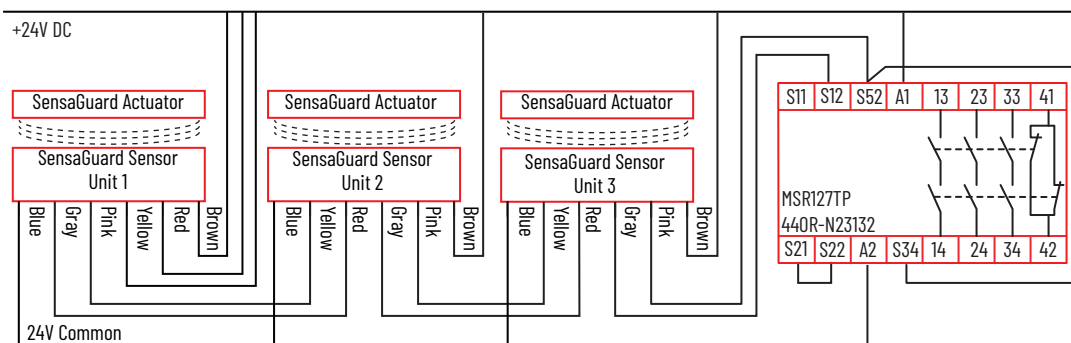

Response Time: Safety outputs turn off.

Initial conditions: All actuators are in sensing distance.

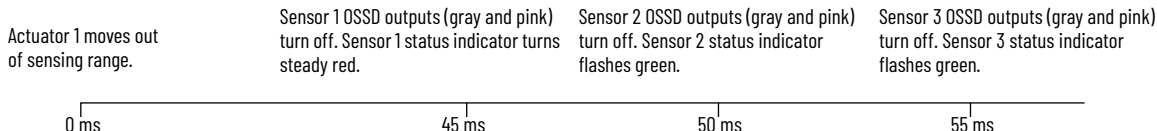

Response Time: Safety outputs turn on

Initial conditions: Actuator 1 is out of sensing range. Sensor 1 status indicator is steady red. Actuators 2 and 3 are in sensing range. Sensor 2 and 3 status indicators flash green.

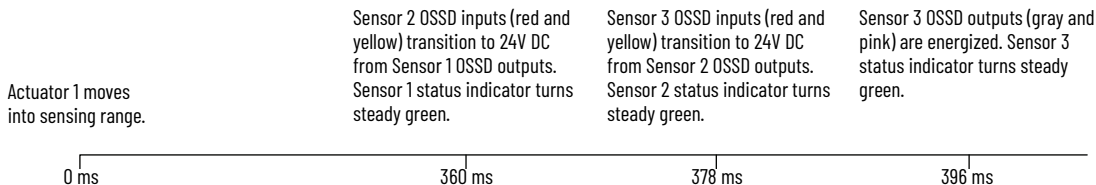

Troubleshooting

Figure 6 - Series Circuit

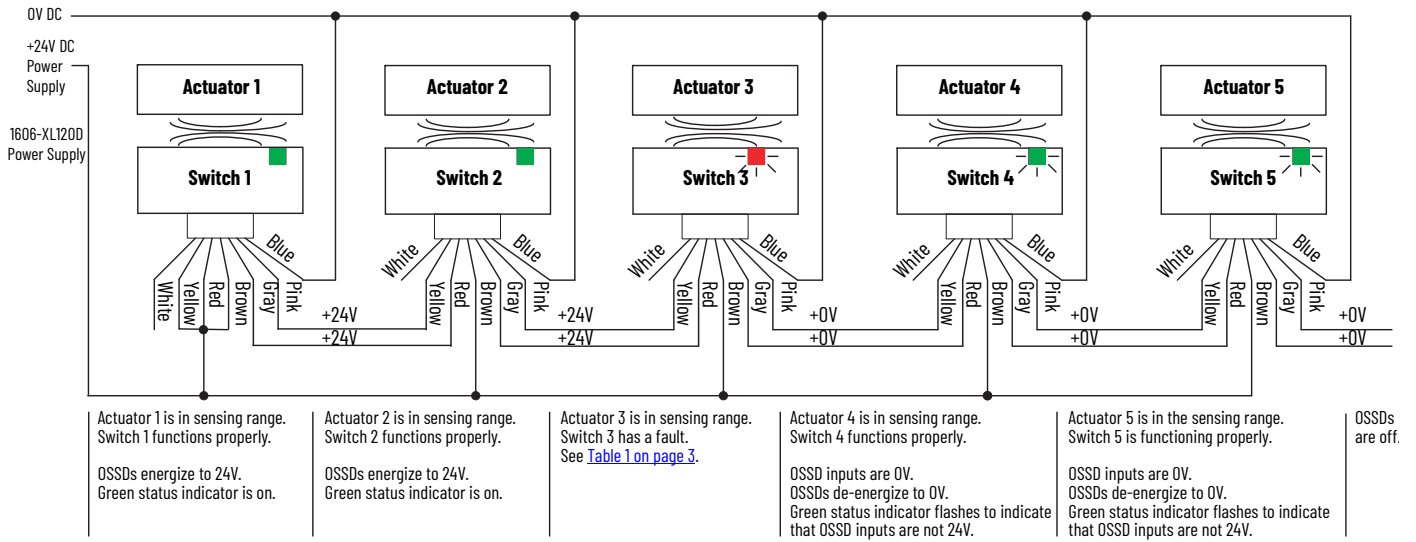

Application Wiring Examples

Figure 7 - Wiring to MSR127 Safety Relay Driving 100S or 700S Safety Relays

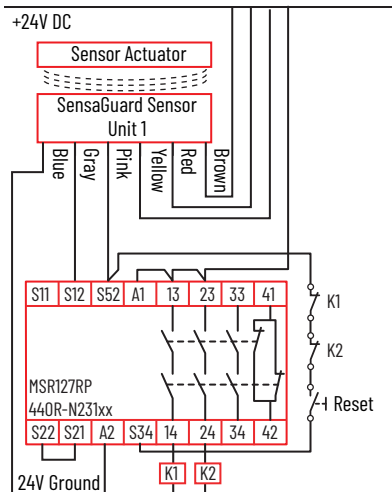

One Sensor, Monitored Manual Reset

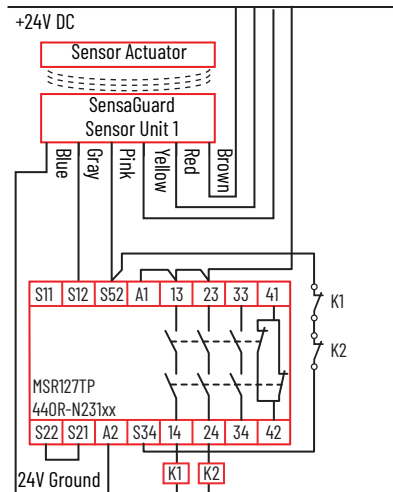

One Sensor, Automatic Reset

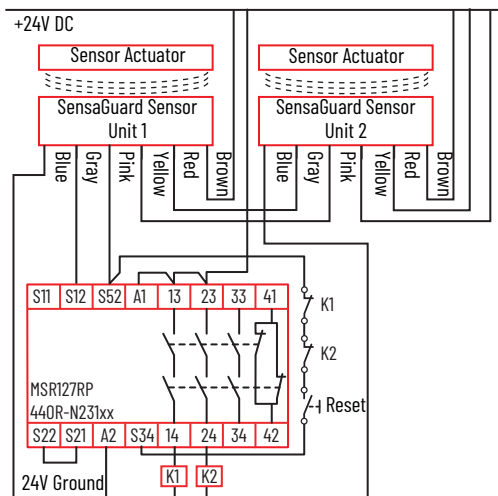

Two Sensors in Series, Monitored Manual Reset

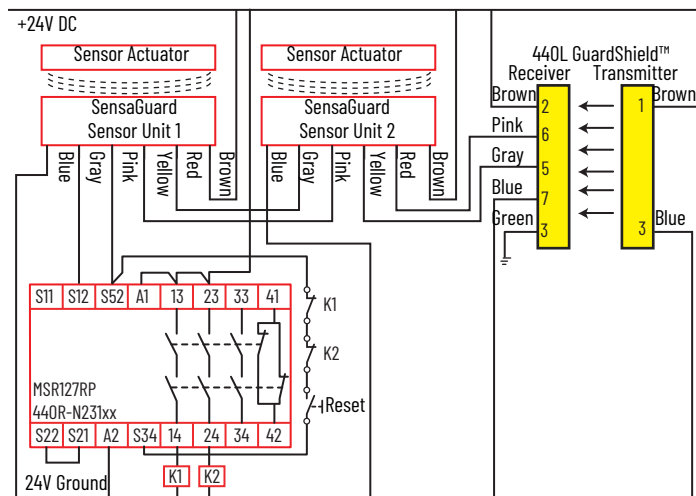

Two Sensors and One 440L Safety Light Curtain in Series, Monitored Manual Reset

IMPORTANT The safety light curtain must be last (farthest from the safety relay).

Figure 8 - Guardmaster SI or DI Safety Relay Wiring

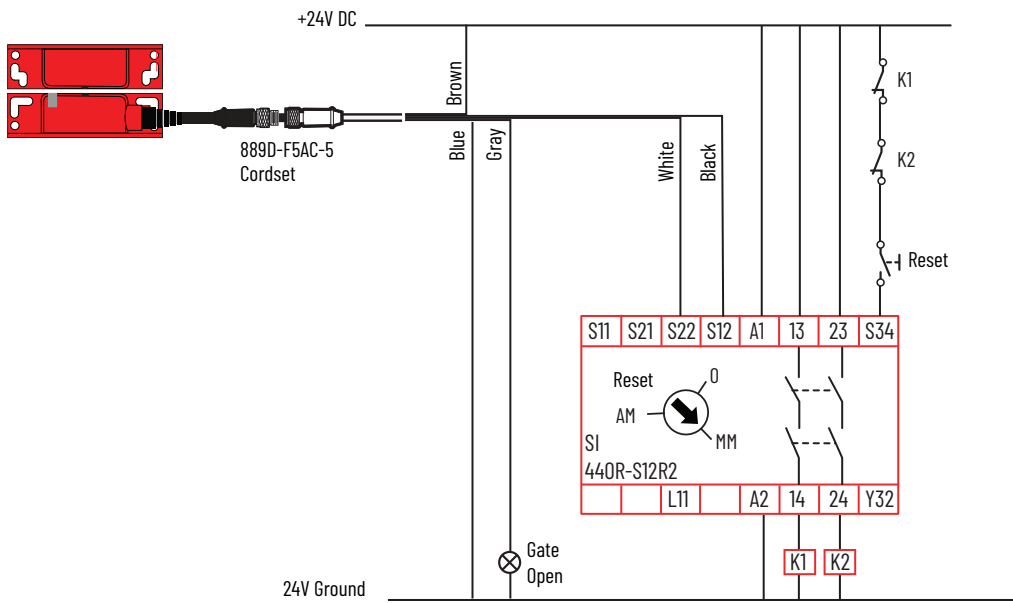
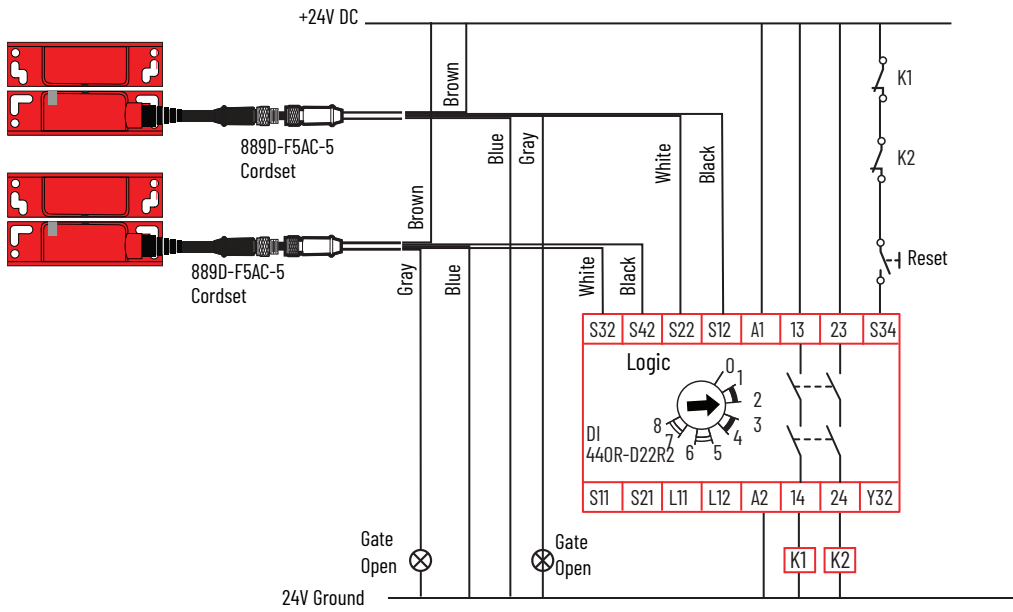

Figure 9 - CR30 Software Configurable Relay Wiring

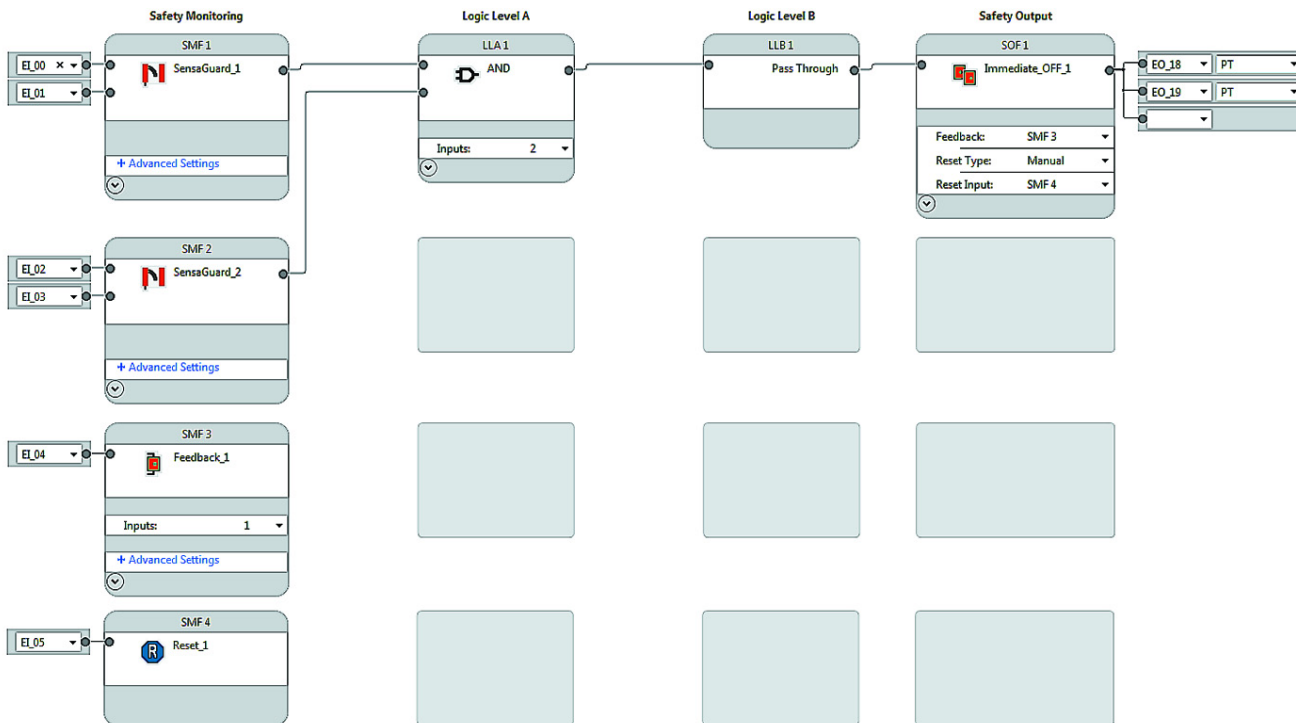
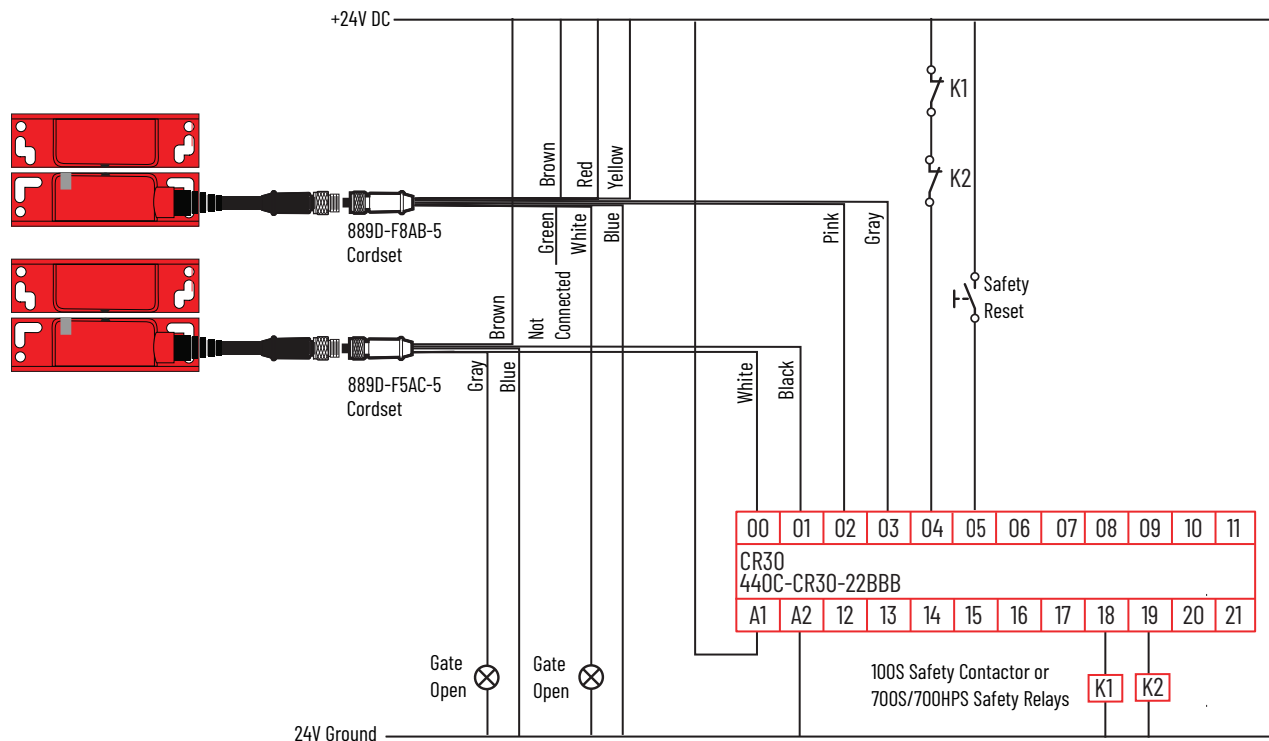
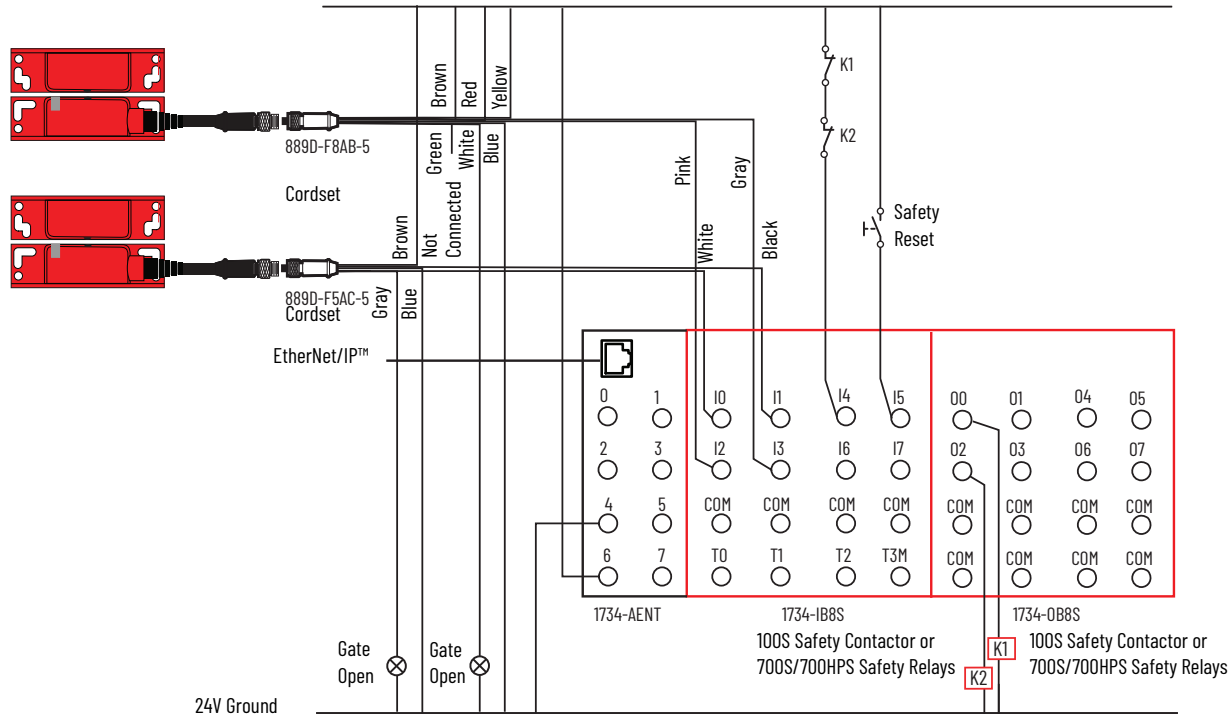

Figure 10 - 1734 POINT Guard I/O Wiring



| Point | Point Operation | | Point Mode | Test Source | Input Delay Time (ms) | |
|-------|-----------------|-----------------------|------------|-------------|-----------------------|---------|
| | Type | Discrepancy Time (ms) | | | Off->On | On->Off |
| 0 | Equivalent | 10 | Safety | None | 0 | 6 |
| 1 | | | Safety | None | 0 | 6 |
| 2 | Equivalent | 10 | Safety | None | 0 | 6 |
| 3 | | | Safety | None | 0 | 6 |
| 4 | Single | 0 | Standard | None | 0 | 0 |
| 5 | | | Standard | None | 0 | 0 |
| 6 | Single | 0 | Not Used | None | 0 | 0 |
| 7 | | | Not Used | None | 0 | 0 |

Set On -> Off Input Delay Time to 6 ms to ignore the SensaGuard OSSD output test pulses.

Figure 11 - 1732DS/ES ArmorBlock Guard Safety I/O Wiring

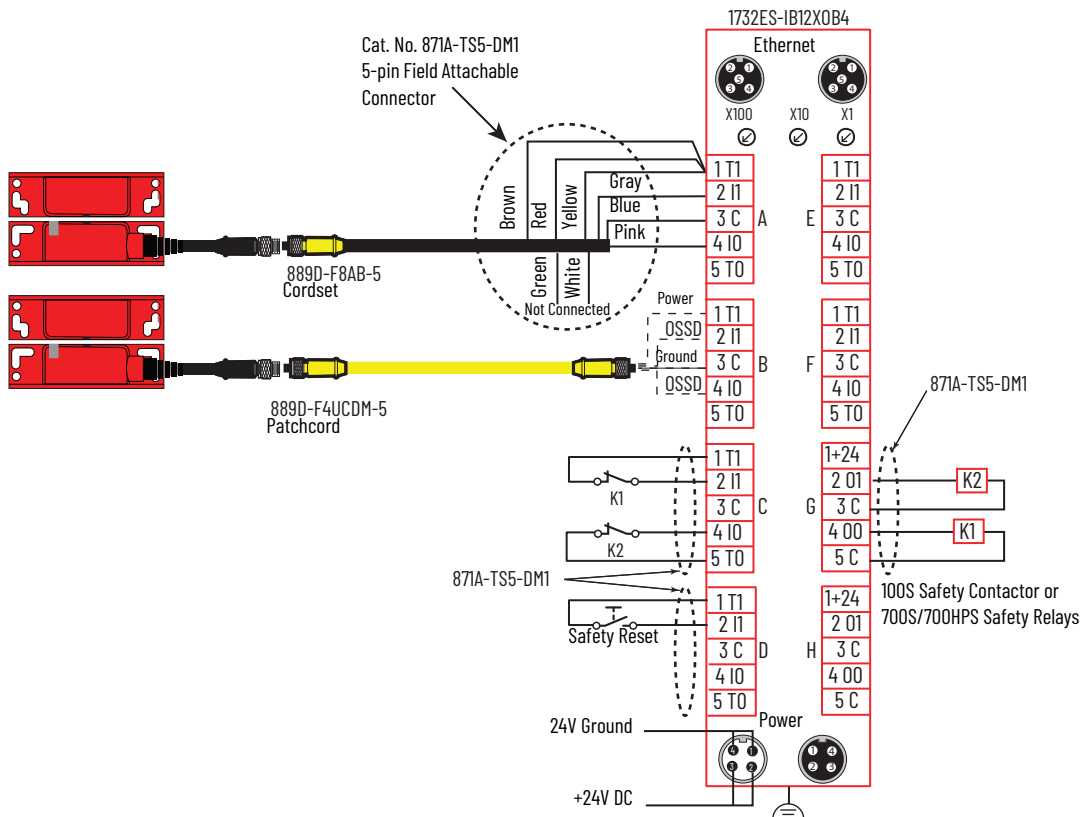

Figure 12 - Input and Output Configuration for the 1732ES Module

| Point | Point Operation | | Point Mode | Test Source | Input Delay Time (ms) | |
|-------|-----------------|-----------------------|-------------------|-------------|-----------------------|---------|
| | Type | Discrepancy Time (ms) | | | Off->On | On->Off |
| 0 | Equivalent | 10 | Safety | None | 0 | 6 |
| 1 | | | Safety | None | 0 | 6 |
| 2 | Equivalent | 10 | Safety | None | 0 | 6 |
| 3 | | | Safety | None | 0 | 6 |
| 4 | Equivalent | 10 | Safety Pulse Test | 4 | 0 | 0 |
| 5 | | | Safety Pulse Test | 5 | 0 | 0 |
| 6 | Single | 0 | Standard | None | 0 | 0 |
| 7 | | | Not Used | None | 0 | 0 |
| 8 | Single | 0 | Not Used | None | 0 | 0 |
| 9 | | | Not Used | None | 0 | 0 |
| 10 | Single | 0 | Not Used | None | 0 | 0 |
| 11 | | | Not Used | None | 0 | 0 |

| Point | Point Mode |
|-------|--------------|
| 0 | Not Used |
| 1 | Power Supply |
| 2 | Not Used |
| 3 | Power Supply |
| 4 | Pulse Test |
| 5 | Pulse Test |
| 6 | Not Used |
| 7 | Power Supply |

| Point | Point Operation | | Point Mode |
|-------|-----------------|-----------------------|------------|
| | Type | Discrepancy Time (ms) | |
| 0 | Dual | | Safety |
| 1 | | | Safety |
| 2 | Dual | | Not Used |
| 3 | | | Not Used |

Recommended Safety Control Interfaces

- Guardmaster[®] safety relays:
 - Dual-input (DI)
 - Dual-input solid-state output (DIS)
 - Single input (SI)
 - CR30 software configurable
- Minotaur[™] safety relays:
 - MSR126
 - MSR127
 - MSR131
 - MSR138
- SmartGuard[™] controller
- 179IDS/ES CompactBlock[™] Guard I/O module
- 1732DS/ES ArmorBlock Guard I/O module
- 1734 POINT Guard I/O[™] module

Maintenance

Monthly: Check the correct operation of the switching circuit. Also check for signs of abuse or interference. Inspect the switch casing for damage.

Repair

If there is any malfunction or damage, no attempts at repair can be made. The unit must be replaced before machine operation is allowed.

Declaration of Conformity

CE Conformity

Rockwell Automation declares that the products that are shown in this document conform with the 2014/30/EU Electromagnetic Compatibility Directive (EMC) and 2006/42/EC Machinery Directive (MD) and that the respective standards and/or technical specifications have been applied.

For a comprehensive CE certificate visit: rok.auto/certifications

UKCA Conformity

Rockwell Automation declares that the products that are shown in this document are in compliance with 2016 No. 1091 Electromagnetic Compatibility Regulations and 2008 No. 1597 Supply of Machinery (Safety) Regulations and that the respective standards and/or technical specifications have been applied.

For a comprehensive UKCA certificate visit: rok.auto/certifications

Additional Resources

| Resource | Description |
|--|---|
| Industrial Automation Wiring and Grounding Guidelines, publication 1770-4.1 | Provides general guidelines for installing a Rockwell Automation industrial system. |
| Product Certifications website, rok.auto/certifications . | Provides declarations of conformity, certificates, and other certification details. |

You can view or download publications at rok.auto/literature.

Rockwell Automation Support

Use these resources to access support information.

| | | |
|---|--|--|
| Technical Support Center | Find help with how-to videos, FAQs, chat, user forums, and product notification updates. | rok.auto/support |
| Knowledgebase | Access Knowledgebase articles. | rok.auto/knowledgebase |
| Local Technical Support Phone Numbers | Locate the telephone number for your country. | rok.auto/phonesupport |
| Literature Library | Find installation instructions, manuals, brochures, and technical data publications. | rok.auto/literature |
| Product Compatibility and Download Center (PCDC) | Download firmware, associated files (such as AOP, EDS, and DTM), and access product release notes. | rok.auto/pcdc |

Documentation Feedback

Your comments help us serve your documentation needs better. If you have any suggestions on how to improve our content, complete the form at rok.auto/docfeedback.





Waste Electrical and Electronic Equipment (WEEE)



At the end of life, this equipment should be collected separately from any unsorted municipal waste.

Rockwell Automation maintains current product environmental compliance information on its website at rok.auto/pec.

Rockwell Otomasyon Ticaret A.Ş. Kar Plaza İş Merkezi E Blok Kat:6 34752 İçerenköy, İstanbul, Tel: +90 (216) 5698400 EEE Yönetmeliğine Uygundur

Connect with us.    

rockwellautomation.com — expanding **human possibility**[®]

AMERICAS: Rockwell Automation, 1201 South Second Street, Milwaukee, WI 53204-2496 USA, Tel: (1) 414.382.2000, Fax: (1) 414.382.4444

EUROPE/MIDDLE EAST/AFRICA: Rockwell Automation NV, Pegasus Park, De Kleetlaan 12a, 1831 Diegem, Belgium, Tel: (32) 2 663 0600, Fax: (32) 2 663 0640

ASIA PACIFIC: Rockwell Automation, Level 14, Core F, Cyberport 3, 100 Cyberport Road, Hong Kong, Tel: (852) 2887 4788, Fax: (852) 2508 1846

UNITED KINGDOM: Rockwell Automation Ltd. Pitfield, Kiln Farm Milton Keynes, MK11 3DR, United Kingdom, Tel: (44)(1908) 838-800, Fax: (44)(1908) 261-917

Allen-Bradley, ArmorBlock, CompactBlock, Guard I/O, expanding human possibility, Guardmaster, GuardShield, Minotaur, POINT Guard I/O, Rockwell Automation, SensaGuard, and SmartGuard are trademarks of Rockwell Automation, Inc.

EtherNet/IP is a trademark of ODVA, Inc.

Trademarks not belonging to Rockwell Automation are property of their respective companies.

Publication 440N-IN018D-EN-P - May 2023 | Supersedes Publication 440N-IN018C-EN-P - August 2020

Copyright © 2023 Rockwell Automation, Inc. All rights reserved. Printed in the U.S.A.