

Industrial Computer and Monitor Specifications

Catalog Numbers 6155F, 6155R, 6176M, 6177R, 6180P, 6181F, 6181P, 6181X, 6186M



Topic	Page
Industrial Computers Comparison	2
Integrated Display Computers	3
Hazardous Location Computers	9
Integrated Display Computers with Keypad	13
Non-display Computers	16
Compact Non-display Computers	19
Industrial Monitors	21
Performance Monitors	22
Standard Monitors	25
HMI Software	28
Additional Resources	35

This document provides technical specifications, environmental specifications, certifications, and dimension drawings for the Allen-Bradley portfolio of industrial computers and monitors from Rockwell Automation.

Use this document with the Visualization Solutions Selection Guide, publication [VIEW-SG001](#), to make initial decisions on the visualization products that are best suited for your system requirements.



Industrial Computers Comparison

Attribute	Integrated Display Computer 6181P, 6181F 1200P, 1500P, 1700P, 1900P	Computer for Hazardous Locations 6181X 1200XT	Display Computer with Keypad 6180P 1200P, 1500P	Non-display Computer 6177R 750R, 1450R	Compact Non-display Computer 6155R/6155F 200R
Display	NDM: non-display option 1200P: 12.1 in. 1500P: 15 in. ⁽²⁾ 1700P: 17 in. 1900P: 19 in. ⁽²⁾	1200XT: non-display option 1200XT: 12.1 in.	1200P: 12.1 in. 1500P: 15 in.	Requires external monitor	Requires external monitor
Available touch screens	Standard and Performance: Resistive Advanced: PCAP ⁽²⁾	Resistive, sunlight readable	Resistive	None	None
Keypad	None	None	Full alphanumeric keypad plus • 1200P: 36 function keys • 1500P: 44 function keys	None	None
Display bezel	Aluminum or stainless steel	Aluminum	Aluminum	None	None
Package options ⁽¹⁾	Standard, Performance, or Advanced	Performance	Standard or Performance	Performance, Advanced, or Server	Standard or Performance
Available processors	Standard: Intel Celeron Performance: Intel i3-4102E Advanced: Intel i7-4700EQ	Intel Core Duo U2500	Standard: Intel Celeron M Performance: Intel Core Duo	Intel Core i3-2120 or Intel Core i5-2400	Intel Celeron M
Primary storage media • Hard disk drive (HDD) • Solid-state drive (SSD) • CompactFlash	100 GB, 2.5 in. SATA 32 GB, SATA	8 GB or 16 GB ⁽⁴⁾	250 GB, 3.5 in. SATA	500 GB, 3.5-in. SATA ⁽⁵⁾	6155R: 100 GB SATA 6155F: 32 GB SATA
RAM memory type (GB installed/max)	Standard: DDR2 (2/4) Performance: DDR3 (4/16) Advanced: DDR3 (8/16)	DDR2 (2/4)	Standard: DDR2 (1/4) Performance: DDR2 (2/4)	DDR3 (4 or 8/32)	Standard: DDR2 (1/2) Performance: DDR2 (2/2)
Expansion slots	1 half-length PCI Express x8 (upgradable to 1 PCI, 2 PCI, 2 PCIe x4, or 1 PCIe x4 + 1 PCI with separate PCI riser kits)	1 half-length PCI	• 2 full-length PCI • 1 half-length PCI • 1 full-length ISA	• 1 or 4 PCI • 1 PCI Express x16 • 1 PCI Express x4 • 1 PCI Express x1	None
Available removable media	Model dependent: DVD-ROM/CD-RW drive or None	None	• DVD-ROM/CD-RW drive • DVD-RW drive	DVD-RW optical disc drive	None
I/O connectors	Up to 16; see pages 5 and 6.	9; see page 11.	15; see page 14.	9; see page 11.	9; see page 11.
Available Windows operating system	• 7 Professional (64 bit) SP1 • Embedded Standard 2009 • Embedded Standard 7 (64 bit) SP1 • Server 2008 R2 (64 bit) SP1	• XP Professional SP3 • 7 Professional (32 bit) SP1	XP Professional SP3	• XP Professional SP3 • 7 Professional (64 bit) SP1 • 8.1 Industry Pro (64 bit) • Server 2008 R2 (64 bit) SP1 • Server 2012 R2 (64 bit)	• XP Professional SP3 • Embedded Standard 2009
CompactFlash quantity	1 or 2 Type II	1 or 2 Type II	None	None	2 Type II
Power	AC or DC	DC	AC or DC	AC	AC or DC
Special requirements	Model dependent: 0...55 °C (32...131 °F) or 0...50 °C (32...122 °F)	• Rated to 70 °C (158 °F) for cULus hazardous, ATEX, and IECEx locations • Preferred monitor: 6186M hazardous location monitor	0...55 °C (32...131 °F)	0...50 °C (32...122 °F)	• Compact form factor • 0...55 °C (32...131 °F)
Mount options	• Panel mount (display models) • Wall (non-display models) • Table ⁽³⁾ • Bookshelf ⁽³⁾ • Machine ⁽³⁾	• Panel mount (display models) • Wall (non-display models)	Panel mount	750R: machine mount 1400R: 4U rack mount	• DIN rail • Machine mount • VESA mount

(1) Package option determines processor type, amount of RAM, type of removable media, number of external connectors or I/O, and type of expansion slots.

(2) Some Advanced models are also available in widescreen formats (16:9 aspect ratio), which have projective capacitive (PCAP) touch screens.

(3) Applies only to series F NDM models. The bookshelf mount requires a bracket (cat. no. 6189V-BOOKBRKT), which is sold separately.

(4) 8 GB for computers with Windows XP Professional and 16 GB for computers with Windows 7 Professional.

(5) RAID 1 enabled server models ship with two 500 GB HDDs.

Integrated Display Computers

Allen-Bradley integrated display computers serve as the foundation for visualization control of processes and machinery by using information displays to repair, maintain, or start a process.

The integrated display computer family features solid-state drives for performance in storage reliability or traditional rotating media for excellent data storage capabilities. Standard, Performance, and Advanced packages provide the computing power that is needed for a range of application requirements.



The complete Rockwell Automation advantage includes seamless integration with the full suite of Rockwell Software® solutions, including Integrated Architecture® and FactoryTalk® View software.

Table 1 - Environmental Specifications - Integrated Display Computers

Attribute	Advanced	Performance	Standard
Temperature, operating			
• NDM (non-display)		0...55 °C (32...131 °F)	
• 1200		0...55 °C (32...131 °F)	0...50 °C (32...122 °F)
• 1500	0...55 °C (32...131 °F) 0...50 °C (32...122 °F) ⁽³⁾	0...55 °C (32...131 °F)	0...50 °C (32...122 °F)
• 1700	0...55 °C (32...131 °F)	0...55 °C (32...131 °F)	0...50 °C (32...122 °F)
• 1900	0...50 °C (32...122 °F)	0...50 °C (32...122 °F)	
Temperature, nonoperating	-20...60 °C (-4...140 °F)		
Relative humidity	10...90% noncondensing at 50%		10...90% noncondensing
Shock, operating ⁽¹⁾⁽²⁾	15 g (1/2 sine, 11 ms)		
Shock, nonoperating ⁽¹⁾⁽²⁾	30 g (1/2 sine, 11 ms)		
Vibration, operating ⁽¹⁾⁽²⁾			
• HDD	0.006 in. p-p, 10...57 Hz, 1 g peak (57...640 Hz)	0.006 in. p-p, 10...57 Hz, 1 g peak sine, 57...640 Hz	
• SSD	0.012 in. p-p, 10...57 Hz, 2 g peak (57...640 Hz)	0.012 in. p-p, 10...57 Hz, 2 g peak sine, 57...640 Hz	
Vibration, nonoperating ⁽¹⁾⁽²⁾			
• HDD	0.012 in. p-p, 10...57 Hz, 2 g peak (57...640 Hz)	0.012 in. p-p, 10...57 Hz, 2 g peak sine, 57...640 Hz	
• SSD	0.018 in. p-p, 10...57 Hz, 3g peak (57...640 Hz)	0.018 in. p-p, 10...57 Hz, 3g peak sine, 57...640 Hz	
Altitude, operating	Sea level to 2,000 m (6,562 ft)		
Altitude, nonoperating	Sea level to 12,192 m (40,000 ft)		
Enclosure ratings			
• With aluminum bezels	UL50 Type 1, 12, and 4 (indoor use only); IEC 60529, IP66	• UL50 Type 1, 12, and 4 (indoor use only); IEC 60529, IP66	NEMA Type 1, 12, 4, and IEC IP66
• With stainless steel bezels		• UL50 Type 1, 12, 4, and 4X (indoor use only); IEC 60529, IP66	

(1) The optical disc drive is considered a maintenance device. Do not operate the drive in environments with the shock and vibration levels listed. Do not operate the drive in temperatures above 45 °C (113 °F).

(2) Does not apply to bookshelf-mounted non-display computers.

(3) This temperature range applies only to widescreen models.

Table 2 - Certifications - 6181P/6181F Integrated Display Computers

Certification ⁽¹⁾	Advanced and Performance Models	Standard Models																																																																					
cULus	UL/c-UL Listed per UL 60950-1 and CSA C22.2 60950-1 second edition	UL/c-UL Listed per UL 60950-1 and CSA C22.2 No. 60950-1-03																																																																					
CE	EMC 2004/108/EC • Immunity standards: EN55024, EN61000-3-2, EN61000-3-3 • Emission standards: EN55022 Class A EN 60950-1 EU REACH: Regulation No. 1907/2006 of the European Parliament ⁽²⁾ Waste Electrical and Electronic Equipment (WEEE) 2002/96/EC Metric Directive 80/181/EEC EU Battery Directive 2006/66/EC Low Voltage Directive: LVD 2006/95/EC	Marked for all applicable directives EMC 2004/108/EC LVD 2006/95/EC																																																																					
EAC (TR CU)	Low Voltage TR CU 004/2011 EMC TR CU 020/2011																																																																						
FCC	Class A emissions																																																																						
Korea	Korean Certification of Broadcasting and Communications Equipment, compliance with Article 58-2 of Radio Waves Act, Clause 2 Emissions standards: Class A 이 기기는 업무용 (A 급) 전자과적합기기로서 판매자 또는 사용자는 이 점을 주의 하시기 바라며, 가정 외의 지역에서 사용하는 것을 목적으로 합니다.																																																																						
RCM (formerly C-Tick)	Emission standards: AS/NZS CISPR 22 Class A	Australian Radiocommunications Act, compliance with: AS/NZS CISPR 11; Industrial Emissions																																																																					
RoHS	European RoHS 2011/65/EU China RoHS: 表格上的信息表示本产品中含有少量的某些材料, 这只适用于中国ROHS. 在这些产品上会有一个显示 " 环境友好使用期限 " 的标签. 这个期限是估算的 " 产品不会有泄露或者突变 " 的年限. 这个产品可能含有某些可替换元件, 这些元件的环境友好使用期限可能比较短. 这些元件会有单独标记. <table border="1" style="width: 100%; border-collapse: collapse; text-align: center;"> <thead> <tr> <th rowspan="2">部件名称</th> <th colspan="6">有毒有害物质或元素</th> </tr> <tr> <th>铅 (Pb)</th> <th>汞 (Hg)</th> <th>镉 (Cd)</th> <th>六价铬 (Cr(VI))</th> <th>多溴联苯 (PBB)</th> <th>多溴二苯醚 (PBDE)</th> </tr> </thead> <tbody> <tr> <td>壳体 (Housing)</td> <td>X</td> <td>○</td> <td>○</td> <td>○</td> <td>○</td> <td>○</td> </tr> <tr> <td>显示 (Display)</td> <td>X</td> <td>○</td> <td>○</td> <td>○</td> <td>○</td> <td>○</td> </tr> <tr> <td>印刷电路板 (Printed Circuit Board)</td> <td>X</td> <td>○</td> <td>○</td> <td>○</td> <td>○</td> <td>○</td> </tr> <tr> <td>金属螺帽 (Metal Fasteners)</td> <td>X</td> <td>○</td> <td>○</td> <td>○</td> <td>○</td> <td>○</td> </tr> <tr> <td>电缆组装 (Cable Assembly)</td> <td>X</td> <td>○</td> <td>○</td> <td>○</td> <td>○</td> <td>○</td> </tr> <tr> <td>风扇组装 (Fan Assembly)</td> <td>X</td> <td>○</td> <td>○</td> <td>○</td> <td>○</td> <td>○</td> </tr> <tr> <td>电力供应组装 (Power Supply Assemblies)</td> <td>X</td> <td>○</td> <td>○</td> <td>○</td> <td>○</td> <td>○</td> </tr> <tr> <td>电池 (Battery)</td> <td>○</td> <td>○</td> <td>○</td> <td>○</td> <td>○</td> <td>○</td> </tr> </tbody> </table> O: 表示该有毒有害物质在该部件所有均质材料中的含量均在SJ/T11363-2006 标准规定的限量要求以下。 X: 表示该有毒有害物质至少在该部件的某一均质材料中的含量超出SJ/T11363-2006 标准规定的限量要求。(企业可在此处, 根据实际情况对上表中打 "X" 的技术原因进行进一步说明。) 这个产品可能含有某些可替换元件, 这些元件的环境友好使用期限可能比较短. 这些元件会有单独标记. 电池: 10 年 Turkey RoHS (EEE Yönetmeliğine Uygundur. In Conformity with the EEE Regulation)	部件名称	有毒有害物质或元素						铅 (Pb)	汞 (Hg)	镉 (Cd)	六价铬 (Cr(VI))	多溴联苯 (PBB)	多溴二苯醚 (PBDE)	壳体 (Housing)	X	○	○	○	○	○	显示 (Display)	X	○	○	○	○	○	印刷电路板 (Printed Circuit Board)	X	○	○	○	○	○	金属螺帽 (Metal Fasteners)	X	○	○	○	○	○	电缆组装 (Cable Assembly)	X	○	○	○	○	○	风扇组装 (Fan Assembly)	X	○	○	○	○	○	电力供应组装 (Power Supply Assemblies)	X	○	○	○	○	○	电池 (Battery)	○	○	○	○	○	○	China RoHS Turkey RoHS (EEE Yönetmeliğine Uygundur. In Conformity with the EEE Regulation)
部件名称	有毒有害物质或元素																																																																						
	铅 (Pb)	汞 (Hg)	镉 (Cd)	六价铬 (Cr(VI))	多溴联苯 (PBB)	多溴二苯醚 (PBDE)																																																																	
壳体 (Housing)	X	○	○	○	○	○																																																																	
显示 (Display)	X	○	○	○	○	○																																																																	
印刷电路板 (Printed Circuit Board)	X	○	○	○	○	○																																																																	
金属螺帽 (Metal Fasteners)	X	○	○	○	○	○																																																																	
电缆组装 (Cable Assembly)	X	○	○	○	○	○																																																																	
风扇组装 (Fan Assembly)	X	○	○	○	○	○																																																																	
电力供应组装 (Power Supply Assemblies)	X	○	○	○	○	○																																																																	
电池 (Battery)	○	○	○	○	○	○																																																																	

(1) When marked; see <http://www.rockwellautomation.com/certification> for declarations of conformity, certificates, and other certification details.
 (2) For current product-environmental information, see <http://www.rockwellautomation.com/rockwellautomation/about-us/sustainability-ethics/product-environmental-compliance-page>.

Table 3 - Technical Specifications - 6181P Integrated Display Computer, Standard Models

Attribute	1200P Standard	1500P Standard	1700P Standard
Display type	Color active-matrix TFT flat panel		
Display size, diagonal	12.1 in. (308 mm)	15 in. (381 mm)	17 in. (432 mm)
Display area (WxH)	246 x 185 mm (9.7 x 7.3 in.)	305 x 229 mm (12 x 9 in.)	338 x 270 mm (13.3 x 10.7 in.)
Display resolution (native)	800 x 600, 256K colors	1024 x 768, 16.7M colors	1280 x 1024, 16.7M colors
Touch screen	Resistive antiglare		
Response time (typical)	15 ms		
Bezel	Aluminum		
Processor	Intel Celeron M423, 1.06 GHz		
RAM <ul style="list-style-type: none"> • Type • Supplied • Maximum 	Dual channel DDR2 DIMM 2 GB (2 x 1 GB) 4 GB (2 x 2 GB)		
Storage drive	6181P: 100 GB, 2.5-in. SATA hard disk drive 6181F: 32GB 2.5-in. SATA solid-state drive		
Expansion slots	None		
Optical storage	None		
CompactFlash	1 Type II slot, bootable ⁽¹⁾		
I/O connections	<ul style="list-style-type: none"> • 1 serial port • 4 USB 2.0 ports • 2 Ethernet LAN ports, 1 Gb each • 3 jacks: audio line-in, audio line-out, and microphone-in 		
Operating system	<ul style="list-style-type: none"> • Windows XP Professional SP3 • Windows Embedded Standard 2009 		
Input voltage, AC	100...240V AC autoranging, 47...63		
Power consumption, AC	100VA (1.0 A at 100V rms, 0.42 A at 240V rms)		
Input voltage, DC	20V DC (power adapter required)		
Power consumption, DC	65 W (3.25 A at 20V)		
Weight, approx	7.85 kg (17.31 lb)	9.0 kg (19.8 lb)	11.0 kg (24.3 lb)
Dimensions (HxWxD), approx	279 x 349 x 99 mm (10.98 x 13.74 x 3.91 in.)	309 x 410 x 95 mm (12.16 x 16.14 x 3.74 in.)	356 x 452 x 95 mm (14.01 x 17.80 x 3.74 in.)
Cutout dimensions (HxWxD)	254 x 324 mm (10 x 12.76 in.)	285.0 x 386.6 mm (11.24 x 15.22 in.)	329.5 x 424.0 mm (12.97 x 16.69 in.)
Mount options	Panel		

(1) The CompactFlash card must be inserted in the bootable slot before power is turned on.

Table 4 - Technical Specifications - 6181P Integrated Display Computers, Performance and Advanced Models**NDM, 1200P, and 1500P Models**

Attribute	NDM (non-display)	1200P	1500P	
		Performance	Performance	Advanced
Display type	—	Color active-matrix TFT flat panel		
Display size, diagonal	—	12 in. (307 mm)	15 in. (381 mm)	<ul style="list-style-type: none"> 15 in. (381 mm) 15.6 in. (396 mm)
Display aspect ratio	—	4:3		<ul style="list-style-type: none"> 4:3 16:9
Display resolution (max)	—	XGA 1024 x 768		<ul style="list-style-type: none"> XGA 1024 x 768 WXGA 1366 x 768
Touch screen	—	Resistive anti-glare		PCAP
Response time	—	15 ms		
Bezel	—	Aluminum	<ul style="list-style-type: none"> Aluminum Stainless steel 	Aluminum
Available processors	<ul style="list-style-type: none"> Intel i3-4102E; 2 cores; 1.6 GHz Intel i7-4700EQ; 4 cores; 2.4 GHz 	Intel i3-4102E; 2 cores; 1.6 GHz		Intel i7-4700EQ; 4 cores; 2.4 GHz
RAM				
• Type	• DDR3-1600 204-pin SO-DIMM	• DDR3-1600 204-pin SO-DIMM		• DDR3-1600 204-pin SO-DIMM
• Supplied	• 4 GB (2 x 2 GB) or 8 GB (2 x 4 GB)	• 4 GB (2 x 2 GB)		• 8 GB (2 x 4 GB)
• Maximum	• 16 GB (2 x 8 GB) ⁽¹⁾	• 16 GB (2 x 8 GB) ⁽¹⁾		• 16 GB (2 x 8 GB) ⁽¹⁾
Available storage drives	<ul style="list-style-type: none"> 1 x 100 GB, 2.5-in. SATA HDD 2 x 100 GB, 2.5-in. SATA HDD (RAID 1) 1 x 32 GB, 2.5-in. SATA SSD 1 x 64 GB, 2.5-in. SATA SSD⁽²⁾ 	<ul style="list-style-type: none"> 1 x 100 GB, 2.5-in. SATA HDD 1 x 32 GB, 2.5-in. SATA SSD 1 x 64 GB, 2.5-in. SATA SSD⁽²⁾ 		
Expansion slots	1 PCI Express x8 ⁽³⁾			
Available optical storage drive (ODD)	<ul style="list-style-type: none"> None supplied 1 DVD-RW/CD-RW 	None supplied		1 DVD-RW/CD-RW
CompactFlash Type II	Type II slot with cover			
I/O connections	<ul style="list-style-type: none"> 1 PS/2™ keyboard port 1 PS/2 mouse port 2 serial RS-232 COM ports 	<ul style="list-style-type: none"> 4 or 5 USB 3.0 external ports⁽⁴⁾ 2 Ethernet LAN ports, 1 Gb each DVI-I port 	<ul style="list-style-type: none"> DisplayPort 3 jacks: audio line-in, audio line-out, and microphone-in 	
Available operating systems ⁽⁵⁾⁽⁶⁾	<ul style="list-style-type: none"> Windows 7 Pro (64 bit) SP1 Windows Server 2008 R2 Standard (64 bit) SP1 WES 7 (64 bit) SP1 	<ul style="list-style-type: none"> Windows 7 Professional (64 bit) SP1 WES 7 (64 bit) SP1 		Windows 7 Professional (64 bit) SP1
Input voltage, AC	100...240V, autoranging			
Power consumption, AC	100...240V; 1.8...0.75 A 50/60 Hz; 180VA			
Input voltage, DC	18...32V			
Power consumption, DC	18...32V; 10.0...5.63 A; 180 W SELV			
Weight, approx				
• Aluminum bezel	7.5 kg (16.5 lb)	8.5 kg (18.7 lb)	9.9 kg (21.8 lb)	9.9 kg (21.8 lb)
• Stainless steel bezel	—	—	11.1 kg (24.5 lb)	—
• Widescreen	—	—	—	10.8 kg (23.8 lb)
Dimensions (HxWxD), approx				
• Performance/Advanced	See Table 6 on page 8			
• Advanced (widescreen)	See Table 6 on page 8			
Cutout dimensions (HxW)				
• Performance/Advanced	—	254 x 324 mm (10 x 12.76 in.)	285.6 x 386.6 mm (11.24 x 15.22 in.)	<ul style="list-style-type: none"> 285.6 x 386.6 mm (11.24 x 15.22 in.) 260.2 x 420 mm (10.24 x 16.54 in.)
• Advanced (widescreen)	—	—	—	—
Mount options	<ul style="list-style-type: none"> Wall Bookshelf⁽⁷⁾ Table top 	Panel		

(1) Maximum memory shipped with computers is 8 GB. 16 GB is available through a kit (catalog number 6189V-16GSODDR3), which is sold separately.

(2) Available through a kit (catalog number 6189V-6181SSD64GB), which is sold separately.

(3) Available one-slot riser kit (catalog number 6189V-PCIR) supports 1 PCI, and two-slot kit (catalog number 6189V-EXTPCI2) supports 2 PCI, 2 PCIe x4, or 1 PCIe x4 plus 1 PCI, all which are half-length.

(4) All display models have four external USB 3.0 ports and one internal USB 3.0 port. Display models with an aluminum bezel have an extra external USB 3.0 port on the bezel (behind the front access cover).

(5) 6181P computers do not ship with the Windows XP Professional operating system but Windows XP system images are available. For more information, contact Rockwell Technical Support (see back page).

(6) 32 bit images for the Windows 7 operating system are available from the Rockwell Automation Product Compatibility and Download Center: <http://www.rockwellautomation.com/support/pcd.page>.

(7) A bookshelf mounting kit (catalog number 6189V-BOOKBRKT) is required and must be ordered separately.

Table 5 - Technical Specifications - 6181P Integrated Display Computers, Performance and Advanced Models
1700P and 1900P Models

Attribute	1700P		1900P	
	Performance	Advanced	Performance	Advanced
Display type	Color active-matrix TFT flat panel			
Display size, diagonal	17 in. (432 mm)		19 in. (483 mm)	<ul style="list-style-type: none"> 19 in. (483 mm) 18.5 in. (470 mm)
Display aspect ratio	5:4			<ul style="list-style-type: none"> 5:4 16:9
Display resolution (max)	SXGA 1280 x 1024		<ul style="list-style-type: none"> SXGA 1280 x 1024 WXGA 1366 x 768 	
Touch screen	Resistive anti-glare	PCAP	Resistive anti-glare	PCAP
Response time	15 ms			
Bezel	<ul style="list-style-type: none"> Aluminum Stainless steel 	Aluminum	<ul style="list-style-type: none"> Aluminum Stainless steel 	Aluminum
Available processors	Intel i3-4102E; 2 cores; 1.6 GHz	Intel i7-4700EQ; 4 cores; 2.4 GHz	Intel i3-4102E; 2 cores; 1.6 GHz	Intel i7-4700EQ; 4 cores; 2.4 GHz
RAM <ul style="list-style-type: none"> Type Supplied Maximum 	<ul style="list-style-type: none"> DDR3-1600 204-pin SO-DIMM 4 GB (2 x 2 GB)⁽¹⁾ 16 GB (2 x 8 GB)⁽¹⁾ 	<ul style="list-style-type: none"> DDR3-1600 204-pin SO-DIMM 8 GB (2 x 4 GB) 16 GB (2 x 8 GB)⁽¹⁾ 	<ul style="list-style-type: none"> DDR3-1600 204-pin SO-DIMM 4 GB (2 x 2 GB)⁽¹⁾ 16 GB (2 x 8 GB)⁽¹⁾ 	<ul style="list-style-type: none"> DDR3-1600 204-pin SO-DIMM 8 GB (2 x 4 GB) 16 GB (2 x 8 GB)⁽¹⁾
Available storage drives	<ul style="list-style-type: none"> 1 x 100 GB, 2.5-in. SATA HDD 1 x 32 GB, 2.5-in. SATA SSD 1 x 64 GB, 2.5-in. SATA SSD⁽²⁾ 			
Expansion slots	1 PCI Express x8 ⁽³⁾			
Available optical storage drive (ODD)	None supplied	1 DVD-RW/CD-RW	None supplied	1 DVD-RW/CD-RW
CompactFlash Type II	Type II slot with cover			
I/O connections	<ul style="list-style-type: none"> 1 PS/2 keyboard port 1 PS/2 mouse port 2 serial RS-232 COM ports 	<ul style="list-style-type: none"> 4 or 5 USB 3.0 external ports⁽⁴⁾ 2 Ethernet LAN ports, 1 Gb each DVI-I port 	<ul style="list-style-type: none"> DisplayPort 3 jacks: audio line-in, audio line-out, and microphone-in 	
Available operating systems ⁽⁵⁾⁽⁶⁾	<ul style="list-style-type: none"> Windows 7 Professional (64 bit) SP1 WES 7 (64 bit) SP1 	Windows 7 Professional (64 bit) SP1	<ul style="list-style-type: none"> Windows 7 Professional (64 bit) SP1 WES 7 (64 bit) SP1 	Windows 7 Professional (64 bit) SP1
Input voltage, AC	100...240V, autoranging			
Power consumption, AC	100...240V; 1.8...0.75 A 50/60 Hz; 180VA			
Input voltage, DC	18...32V			
Power consumption, DC	18...32V; 10.0...5.63 A; 180 W SELV			
Weight, approx <ul style="list-style-type: none"> Aluminum bezel Stainless steel bezel Widescreen 	11.1 kg (24.5 lb) 12.8 kg (28.2 lb) —	11.1 kg (24.5 lb) — —	13.2 kg (29.1 lb) 14.5 kg (32 lb) —	13.2 kg (29.1 lb) — 13 kg (28.7 lb)
Dimensions (HxWxD), approx <ul style="list-style-type: none"> Performance/Advanced Advanced (widescreen) 	See Table 6 on page 8 See Table 6 on page 8			
Cutout dimensions (HxW) <ul style="list-style-type: none"> Performance/Advanced Advanced (widescreen) 	329.5 x 424.0 mm (12.97 x 16.69 in.) —		363.5 x 449.6 mm (14.31 x 17.7 in.) —	<ul style="list-style-type: none"> 363.5 x 449.6 mm (14.31 x 17.7 in.) 321 x 493 mm (12.64 x 19.41 in.)
Mount options	Panel			

- (1) Maximum memory shipped with computers is 8 GB. 16 GB is available through a kit (catalog number 6189V-16GSODDR3), which is sold separately.
- (2) Available through a kit (catalog number 6189V-6181SSD64GB), which is sold separately.
- (3) Available one-slot riser kit (catalog number 6189V-PCIR) supports 1 PCI, and two-slot kit (catalog number 6189V-EXTPC12) supports 2 PCI, 2 PCIe x4, or 1 PCIe x4 plus 1 PCI, all which are half-length.
- (4) All display models have four external USB 3.0 ports and one internal USB 3.0 port. Display models with an aluminum bezel have an extra external USB 3.0 port on the bezel (behind the front access cover).
- (5) 6181P computers do not ship with the Windows XP Professional operating system but Windows XP system images are available. For more information, contact Rockwell Technical Support (see back page).
- (6) 32 bit images for the Windows 7 operating system are available from the Rockwell Automation Product Compatibility and Download Center: <http://www.rockwellautomation.com/support/pdcd.page>.

Dimensions - Integrated Display Computer

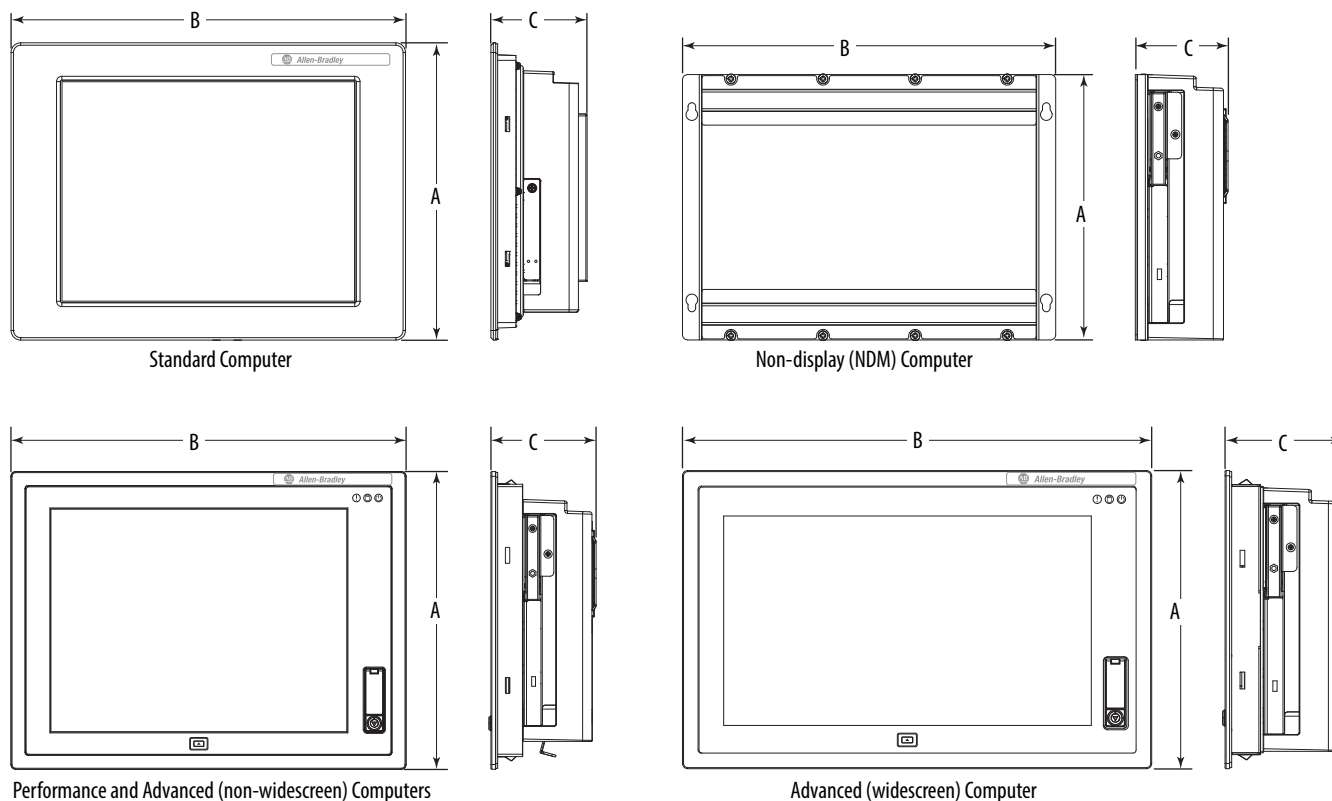

Table 6 - Dimensions - Integrated Display Computers

6181P/6181F Integrated Display Computer	Overall Height A	Overall Width B	Overall Depth C	Cutout Height	Cutout Width
Non-display (NDM)					
Performance	251 mm (9.88 in.)	353 mm (13.90 in.)	83.4 mm (3.28 in.)	—	—
Advanced			87.7 mm (3.45 in.)		
1200P					
Standard	279 mm (10.98 in.)	349 mm (13.74 in.)	99.4 mm (3.91 in.)	254 mm (10 in.)	324 mm (12.76 in.)
Performance			104.8 mm (4.13 in.)		
1500P					
Standard	309 mm (12.16 in.)	410 mm (16.14 in.)	95 mm (3.74 in.)	285.6 mm (11.24 in.)	386.6 mm (15.22 in.)
Performance			104.8 mm (4.13 in.)		
Stainless steel			104.1 mm (4.10 in.)		
Advanced (non-widescreen)			104.8 mm (4.13 in.)		
Advanced (widescreen)	284 mm (11.18 in.)	447 mm (17.6 in.)	108.1 mm (4.26 in.)	260.2 mm (10.24 in.)	420 mm (16.54 in.)
1700P					
Standard	356 mm (14.01 in.)	452 mm (17.80 in.)	95 mm (3.74 in.)	329.5 mm (12.97 in.)	424 mm (16.69 in.)
Performance			104.8 mm (4.13 in.)		
Stainless steel			104.1 mm (4.10 in.)		
Advanced (non-widescreen)			104.8 mm (4.13 in.)		
1900P					
Performance	399.3 mm (15.72 in.)	482.6 mm (19 in.)	108.1 mm (3.94 in.)	363.5 mm (14.31 in.)	449.6 mm (17.7 in.)
Stainless steel					
Advanced (non-widescreen)					
Advanced (widescreen)	339.3 mm (13.36 in.)	515.6 mm (20.3 in.)		321 mm (12.64 in.)	493 mm (19.41 in.)

Hazardous Location Computers



With Class I Division 2, ATEX, and IECEx hazardous location certifications, this extreme environment computer can be safely used globally in areas where explosive materials can be present. The display version of this computer mounts in a panel while the non-display version mounts on a wall. Both computers can withstand temperatures of $-20...70\text{ }^{\circ}\text{C}$ ($-4...158\text{ }^{\circ}\text{F}$) inside a cabinet or enclosure. The front of the display computer can withstand ambient temperatures in the range $-20...55\text{ }^{\circ}\text{C}$ ($-4...131\text{ }^{\circ}\text{F}$).

Table 7 - Environmental Specifications - Hazardous Location Computers

Attribute	1200XT Non-display, 1200XT Display (12 in.)
Temperature, operating 6181X-NPXPDC, non-display 6181X-12TPXPDC, display	$-20...70\text{ }^{\circ}\text{C}$ ($-4...158\text{ }^{\circ}\text{F}$) $-20...55\text{ }^{\circ}\text{C}$ ($-4...131\text{ }^{\circ}\text{F}$), display side $-20...70\text{ }^{\circ}\text{C}$ ($-4...158\text{ }^{\circ}\text{F}$), back side
Temperature, nonoperating	$-30...80\text{ }^{\circ}\text{C}$ ($-22...176\text{ }^{\circ}\text{F}$)
Relative humidity	10...90% noncondensing
Altitude, operating	2,000 m (6,561 ft)
Altitude, nonoperating	12,000 m (40,000 ft)
Vibration, operating	0.012 in. p-p 10...57 Hz 2 g peak at 57...640 Hz
Shock, operating	15 g (1/2 sine, 11 ms)
Shock, nonoperating	30 g (1/2 sine, 11 ms)
Enclosure ratings (display models)	UL NEMA Type 4X and 12 IP66 as classified by UL

Table 8 - Hazardous Location Ratings by Region

Computer Model	Cat. Nos.	Region	Rating	Temperature Range	
Non-display	6181X-NPXPDC, 6181X-NPW7DC	United States	Class I Division 2, Groups A, B, C, D T4	$-20\text{ }^{\circ}\text{C} \leq T_a \leq 70\text{ }^{\circ}\text{C}^{(1)}$ ($-4\text{ }^{\circ}\text{F} \leq T_a \leq 158\text{ }^{\circ}\text{F}$)	
			Class I Zone 2, IIC, T4		
		Canada	Class I Division 2, Groups A, B, C, D T4		
			Class I Zone 2, IIC, T4		
Europe	ATEX II 3 GD, Ex nA IIC Gc, Ex tc IIIC Dc				
Global/IECEx	II 3 GD, Ex nA IIC Gc, Ex tc IIIC Dc				
Display (12 in.)	6181X-12TPXPDC, 6181X-12TPW7DC	United States	Class I Division 2, Groups A, B, C, D T4	$-20\text{ }^{\circ}\text{C} \leq T_a \leq 55\text{ }^{\circ}\text{C}$ ($-4\text{ }^{\circ}\text{F} \leq T_a \leq 131\text{ }^{\circ}\text{F}$) (display side)	
			Class I Zone 2, IIC, T4		
		Canada	Class I Division 2, Groups A, B, C, D T4		$-20\text{ }^{\circ}\text{C} < T_a < 70\text{ }^{\circ}\text{C}$ ($-4\text{ }^{\circ}\text{F} < T_a < 158\text{ }^{\circ}\text{F}$) (backside) ⁽¹⁾
			Class I Zone 2, IIC, T4		
Europe	ATEX II 3 GD, Ex nA nC IIC T4 Gc, Ex tc IIIC T135 °C Dc				
Global/IECEx	II 3 GD, Ex nA nC IIC T4 Gc, Ex tc IIIC T135 °C Dc				

(1) The entire non-display computer and the backside of the display computer are required to be mounted in a restricted access location.

Table 9 - Certifications

Attribute ⁽¹⁾	1200XT Non-display, 1200XT Display																																																																					
cULus	UL/c-UL Listed as Information Technology Equipment for use in Hazardous Locations per standards ANSI/ISA 12.12.01, CSA C22.2 No. 213 Enclosure Type ratings per UL50 and CSA C22.2 No. 94.2-07 Enclosure ingress protection Classified by UL per IEC 60529																																																																					
IECEX	IEC60079-0 2011 IEC60079-15 2010 IEC60079-31 2013 IECEX DNV 14.0011X (for display computers) IECEX DNV 14.0012U (for non-display computers)																																																																					
ATEX	EN60079-0 2012 EN60079-15 2010 EN60079-31 2014 DNV 11 ATEX 94276X (for display computers) DNV 11 ATEX 94276U (for non-display computers)																																																																					
CE	EMC 2004/108/EC • Immunity standards: EN55024 • Emission standards: EN55022 Class A ATEX 94/9/EC Waste Electrical and Electronic Equipment (WEEE) 2002/96/EC Metric Directive 80/181-EEC EU Battery Directive 2006/66/EC Low Voltage Directive: LVD 2006/95/EC • EN 60950-1																																																																					
FCC	Class A emissions																																																																					
RoHS	<p>European RoHS 2011/65/EU</p> <p>China RoHS:</p> <p>表格上的信息表示本产品中含有少量的某些材料, 这只适用于中国ROHS.</p> <p>在这些产品上会有一个显示 " 环境友好使用期限 " 的标签. 这个期限是估算的 " 产品不会有泄露或者突变 " 的年限.</p> <p>这个产品可能含有某些可替换元件, 这些元件的环境友好使用期限可能比较短. 这些元件会有单独标记.</p> <table border="1"> <thead> <tr> <th rowspan="2">部件名称</th> <th colspan="6">有毒有害物质或元素</th> </tr> <tr> <th>铅 (Pb)</th> <th>汞 (Hg)</th> <th>镉 (Cd)</th> <th>六价铬 (Cr(VI))</th> <th>多溴联苯 (PBB)</th> <th>多溴二苯醚 (PBDE)</th> </tr> </thead> <tbody> <tr> <td>壳体 (Housing)</td> <td>X</td> <td>○</td> <td>○</td> <td>○</td> <td>○</td> <td>○</td> </tr> <tr> <td>显示 (Display)</td> <td>X</td> <td>○</td> <td>○</td> <td>○</td> <td>○</td> <td>○</td> </tr> <tr> <td>印刷电路板 (Printed Circuit Board)</td> <td>X</td> <td>○</td> <td>○</td> <td>○</td> <td>○</td> <td>○</td> </tr> <tr> <td>金属螺帽 (Metal Fasteners)</td> <td>X</td> <td>○</td> <td>○</td> <td>○</td> <td>○</td> <td>○</td> </tr> <tr> <td>电缆组装 (Cable Assembly)</td> <td>X</td> <td>○</td> <td>○</td> <td>○</td> <td>○</td> <td>○</td> </tr> <tr> <td>风扇组装 (Fan Assembly)</td> <td>X</td> <td>○</td> <td>○</td> <td>○</td> <td>○</td> <td>○</td> </tr> <tr> <td>电力供应组装 (Power Supply Assemblies)</td> <td>X</td> <td>○</td> <td>○</td> <td>○</td> <td>○</td> <td>○</td> </tr> <tr> <td>电池 (Battery)</td> <td>○</td> <td>○</td> <td>○</td> <td>○</td> <td>○</td> <td>○</td> </tr> </tbody> </table> <p>O: 表示该有毒有害物质在该部件所有均质材料中的含量均在SJ/T11363-2006 标准规定的限量要求以下。</p> <p>X: 表示该有毒有害物质至少在该部件的某一均质材料中的含量超出SJ/T11363-2006 标准规定的限量要求。(企业可在此处, 根据实际情况对上表中打 "X" 的技术原因进行进一步说明。)</p> <p>这个产品可能含有某些可替换元件, 这些元件的环境友好使用期限可能比较短. 这些元件会有单独标记.</p> <p>电池: 10 年</p> <p>Turkey RoHS (EEE Yönetmeliğine Uygundur. In Conformity with the EEE Regulation)</p>	部件名称	有毒有害物质或元素						铅 (Pb)	汞 (Hg)	镉 (Cd)	六价铬 (Cr(VI))	多溴联苯 (PBB)	多溴二苯醚 (PBDE)	壳体 (Housing)	X	○	○	○	○	○	显示 (Display)	X	○	○	○	○	○	印刷电路板 (Printed Circuit Board)	X	○	○	○	○	○	金属螺帽 (Metal Fasteners)	X	○	○	○	○	○	电缆组装 (Cable Assembly)	X	○	○	○	○	○	风扇组装 (Fan Assembly)	X	○	○	○	○	○	电力供应组装 (Power Supply Assemblies)	X	○	○	○	○	○	电池 (Battery)	○	○	○	○	○	○
部件名称	有毒有害物质或元素																																																																					
	铅 (Pb)	汞 (Hg)	镉 (Cd)	六价铬 (Cr(VI))	多溴联苯 (PBB)	多溴二苯醚 (PBDE)																																																																
壳体 (Housing)	X	○	○	○	○	○																																																																
显示 (Display)	X	○	○	○	○	○																																																																
印刷电路板 (Printed Circuit Board)	X	○	○	○	○	○																																																																
金属螺帽 (Metal Fasteners)	X	○	○	○	○	○																																																																
电缆组装 (Cable Assembly)	X	○	○	○	○	○																																																																
风扇组装 (Fan Assembly)	X	○	○	○	○	○																																																																
电力供应组装 (Power Supply Assemblies)	X	○	○	○	○	○																																																																
电池 (Battery)	○	○	○	○	○	○																																																																
RCM (formerly C-Tick)	Australian Radiocommunications Act, compliance with AS/NZS CISPR 22																																																																					

(1) See <http://www.rockwellautomation.com/rockwellautomation/certification/overview.page> for declarations of conformity, certificates, and other certification details.

Table 10 - Technical Specifications - 6181X Hazardous Location Computers

Attribute	1200XT Non-display	1200XT Display
Display type	No display	Active matrix color TFT
Touch screen	—	Resistive anti-glare, sunlight readable
Display size, diagonal	—	308 mm (12.1 in.)
Display area (WxH)	—	246 x 185 mm (9.7 x 7.3 in.)
Resolution	—	800 x 600, 16.2M colors
Display brightness	—	600 cd/m ² , typical
Contrast ratio	—	1500:1, typical
View angle	—	178° typical
Status indicator backlight lifetime	—	50,000 hours max at 25 °C (77 °F)
Bezel	—	Aluminum
Processor	Intel Core Duo U2500, 1.2 GHz	
RAM	2 GB DDR2 installed (4 GB max)	
Expansion slots	1 half-length PCI	
CompactFlash Type II slot Computer side Computer bottom	2 bootable slots True IDE, OS drive installed ⁽¹⁾ Data drive (shipped empty)	
I/O connections	<ul style="list-style-type: none"> • 2 serial COM ports • 4 USB 2.0 ports, hot-swappable • 2 Ethernet LAN ports, 1 Gb each • 1 DVI-I port 	
Available operating systems	<ul style="list-style-type: none"> • Windows 7 Professional (32 bit), SP1 • Windows XP Professional, SP3 	
Input voltage, DC	18...32V DC	
Power consumption, DC (max)	18...32V DC (SELV), 2.46...1.34 A, 45 W	18...32V DC (SELV), 3.28...1.79 A, 60 W
Heat dissipation ⁽²⁾	45 W (154 BTU/h)	60 W (205 BTU/h)
Weight, approx	6.1 kg (13.45 lb)	8.4 kg (18.52 lb)
Dimensions (HxWxD), approx	251 x 353 x 83.4 mm 7.50 x 13.20 x 3.28 in.	279 x 349 x 101.2 mm 10.98 x 13.74 x 3.98 in.
Cutout dimensions (HxWxD)	—	254 x 324 mm 10 x 12.76 in.
Mount options	Wall	Panel

(1) For computers with Windows XP Professional, the CF card is 8 GB. For computers with Windows 7 Professional, the CF card is 16 GB.

(2) Add-in cards and peripherals are included in the heat dissipation value.

Dimensions - Hazardous Location Computers

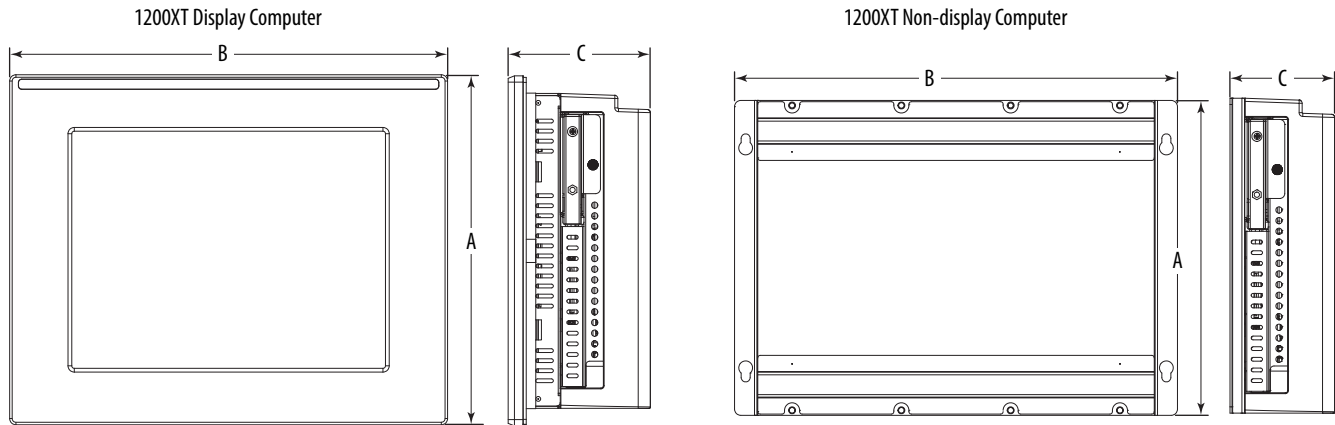

Table 11 - Dimensions - Hazardous Location Computers

6181X Hazardous Location Computer	Overall Height A	Overall Width B	Overall Depth C
1200XT display	279 mm (10.98 in.)	349 mm (13.74 in.)	101.2 mm (3.98 in.)
1200XT non-display	190 mm (7.5 in.)	335 mm (13.20 in.)	83.4 mm (3.28 in.)

Integrated Display Computers with Keypad

As either an operator input station or an industrial computer, the 6180P platform features an integrated display and a programmable keypad in the same unit. The absence of external monitor cables and separate component-mounting requirements allows for simple system integration. With an operating temperature range of 0...55 °C (32...131 °F), these panel mount computers can withstand demanding factory-floor applications.



Table 12 - Environmental Specifications - 6180P Display Computers with Keypad

Attribute	1200P, 1500P
Temperature, operating	0...55 °C (32...131 °F)
Temperature, nonoperating	-20...60 °C (-4...140 °F)
Relative humidity, operating ⁽¹⁾	20...85% noncondensing
Relative humidity, nonoperating ⁽²⁾	5...90% noncondensing
Vibration, operating	0.006 in. p-p 10...57 Hz, 1 g peak at 57...640 Hz
Vibration, nonoperating	0.012 in. p-p, (10...57 Hz), 2 g peak, (57...640 Hz)
Shock, operating	15 g (1/2 sine, 11 ms)
Shock, nonoperating	30 g (1/2 sine, 11 ms)
Enclosure ratings	NEMA Type 1, 12, 4 IEC IP66

(1) Derate above 40 °C to 45% at 50 °C.

(2) Derate above 40 °C to 39% at 60 °C.

Table 13 - Certifications - 6180P Display Computers with Keypad

Certification ⁽¹⁾	1200P, 1500P
cULus	UL/c-UL Listed per UL 60950-1 and CSA C22.2 No. 60950-1
CE	Marked for all applicable directives EMC 2004/108/EC (as amended by 92/31/EEC and 93/68/EEC) LVD 2006/95/EC
RCM (formerly C-Tick)	Australian Radiocommunications Act, compliance with: AS/NZS CISPR 22; Industrial Emissions
RoHS	China

(1) When marked. See the Product Certification link at <http://www.rockwellautomation.com/rockwellautomation/certification/overview.page> for declarations of conformity, certificates, and other certification details.

Table 14 - Technical Specifications - 6180P Integrated Display Computers with Keypad

Attribute	1200P	1500P
Display type	Color active-matrix TFT flat panel	Color active-matrix TFT flat panel
Display size, diagonal	12.1 in. (308 mm)	15 in. (381 mm)
Display area (WxH)	246 x 185 mm (9.7 x 7.3 in.)	305 x 229 mm (12 x 9 in.)
Resolution	800 x 600, native mode, 256K colors	1024 x 768, native mode, 256K colors
Luminance	250 cd/m ² Nits	350 cd/m ² Nits
Response time, max	20 ms	20 ms
Touch screen option	Resistive antiglare	
Keypad description	36 function keys Full alphanumeric keypad	44 function keys Full alphanumeric keypad
Processor	Celeron M 1.86 GHz Core Duo 2.0 GHz	Celeron M 1.86 GHz Core Duo 2.0 GHz
RAM	1 GB DDR2 2 GB DDR2	1 GB DDR2 2 GB DDR2
Storage drive	250 GB, 3.5-in. SATA hard disk drive	250 GB, 3.5-in. SATA hard disk drive
Optical storage device	DVD-ROM/CD-RW drive DVD-RW drive	
Expansion slots	2 full-length PCI, 1 half-length PCI, 1 full-length ISA	
I/O connections	<ul style="list-style-type: none"> • 2 serial ports • 1 parallel port • 6 USB 2.0 ports, • 2 Ethernet LAN ports, 1 Gb each • 1 DVI-I port • 3 audio ports 	
Operating system	Windows XP Professional SP3	
Input voltage, AC	90...264V AC autoranging, 47...63	
Power consumption, AC	160VA (1.6 A at 100V rms, 0.67 A at 240V rms)	
Input voltage, DC	19...32V DC	
Power consumption, DC	180 W (7.5 A at 24V DC)	
Inrush current at 24V	20 A peak, ms	
Weight, approx	17.0 kg (37.4 lb)	18.5 kg (40.8 lb)
Dimensions (HxWxD), approx	311 x 483 x 225 mm (12.25 x 19.01 x 8.86 in.)	355 x 483 x 225 mm (13.97 x 19.01 x 8.86 in.)
Cutout dimensions (HxWxD)	279 x 450 mm (10.98 x 17.72 in.)	326.4 x 429.3 mm (12.85 x 16.90 in.)
Mount options	Panel	Panel

Dimensions - Integrated Display with Keypad

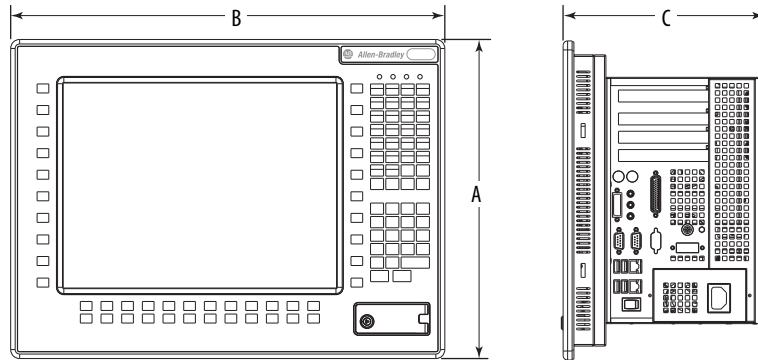

Table 15 - Dimensions - Integrated Display Computers with Keypad

6180P Display Computer with Keypad	Overall Height A	Overall Width B	Overall Depth C	Cutout Width	Cutout Height
1200P	311 mm (12.25 in.)	483 mm (19.01 in.)	225 mm (8.86 in.)	450 mm (17.72 in.)	279 mm (10.98 in.)
1500P	355 mm (13.97 in.)	483 mm (19.01 in.)	225 mm (8.86 in.)	429.3 mm (16.90 in.)	326.4 mm (12.85 in.)

Non-display Computers

The 6177R non-display computers take advantage of the Intel second-generation core processors to provide powerful platforms that are suited with excellent reliability for industrial environments. These computers are available in rugged machine-mount and rack-mount form factors and offer powerful remote management, onboard backup/restore, and integrated diagnostic capabilities.

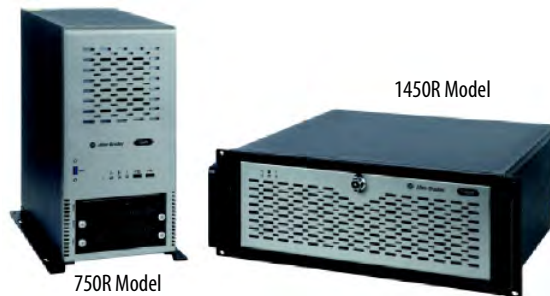

Table 16 - Environmental Specifications - 6177R Non-display Computers

Attribute	750R, 1450R	
Temperature, operating	0...50 °C (32...122 °F)	
Temperature, nonoperating	-20...60 °C (-4...140 °F)	
Relative humidity	10...90% noncondensing	
Vibration, operating	0.006 in. p-p 10...57 Hz, 1 g peak at 57...640 Hz	
Vibration, nonoperating	0.012 in. p-p 10...57 Hz, 2 g peak at 57...640 Hz	
Shock, operating	15 g (1/2 sine, 11 ms)	
Shock, nonoperating	30 g (1/2 sine, 11 ms)	
Acoustic noise, idle	750R	44.3 dB at 50 cm
	1450R	46.6 dB at 50 cm
Acoustic noise, max	750R	63.4 dB at 50 cm
	1450R	64.4 dB at 50 cm

Table 17 - Certifications - 6177R Non-display Computers

Certification ⁽¹⁾	750R, 1450R
cULus	Safety: UL/c-UL Listed per UL 60950-1
CE	Immunity standards: EN55024, EN6100-3-2, EN6100-3-3 Emission standards: EN55022 Class A Low Voltage Directive: LVD 2006/95/EC
FCCR	Class A emissions
RCM (formerly C-Tick)	Emissions standards: AS/NZS CISPR 22 Class A
KCC	Emissions standards: Class A 이 기기는 업무용(A급) 전자파적합기기로서 판매자 또는 사용자는 이 점을 주의하시기 바라며, 가정외의 지역에서 사용하는 것을 목적으로 합니다.
RoHS	European China

(1) When marked. See the Product Certification link at <http://www.rockwellautomation.com/rockwellautomation/certification/overview.page> for declarations of conformity, certificates, and other certification details.

Table 18 - Technical Specifications - 6177R Non-display Computers

Attribute	750R	1450R
Display type	Requires external monitor	Requires external monitor
Available operating systems	Windows 7 Professional (64 bit) SP1, Windows XP Professional SP3, or no operating system Windows Embedded 8.1 Industry Professional or Windows 7 Professional (64 bit) SP1 Windows Server 2012 Standard R2, Windows Server 2008 R2 SP1, or no operating system	
Processor	Performance Advanced Server	Performance Advanced Server
	Intel Core i3-2120, 3.3 GHz Intel Core i5-2400, 3.1 GHz Intel Core i5-2400, 3.1 GHz	Intel Core i3-2120, 3.3 GHz Intel Core i5-2400, 3.1 GHz Intel Core i5-2400, 3.1 GHz
Ethernet LAN	2 ports, 10/100/1000 Mbps	
RAM memory	Performance Advanced Server	Performance Advanced Server
	4 GB DDR3, 32 GB max 8 GB DDR3, 32 GB max 8 GB DDR3, 32 GB max	4 GB DDR3, 32 GB max 8 GB DDR3, 32 GB max 8 GB DDR3, 32 GB max
Storage drive	Performance Advanced Server	Performance Advanced Server
	(1) 500 GB, 3.5-in. SATA HDD (1) 500 GB, 3.5-in. SATA HDD (2) 500 GB, 3.5-in. SATA HDD	(1) 500 GB, 3.5-in. SATA HDD (1) 500 GB, 3.5-in. SATA HDD (2) 500 GB, 3.5-in. SATA HDD
RAID 1 enabled	Performance Advanced Server	Performance Advanced Server
	No No Yes	No No Yes
RAID capabilities	RAID 0 or RAID 1 with second HDD installed and RAID array configured	
Optical disc drive (ODD)	DVD-RW	DVD-RW
Expansion slots	<ul style="list-style-type: none"> • 1 PCI (750R) or 4 PCI (1450R) • 1 PCI Express x16 • 1 PCI Express x4 • 1 PCI Express x1 	
I/O ports	<ul style="list-style-type: none"> • 1 PS/2 keyboard • 1 PS/2 mouse • 2 serial • 1 parallel • 2 Ethernet LAN ports, 1 Gb each • 7 USB 2.0 ports (4 rear, 2 front, 1 internal) • 2 USB 3.0 ports (1 rear, 1 front) • 1 eSATAp (5V, 500 mA) • 2 DVI (DVI-1, DVI-D) DVI-1 port converts to VGA with supplied adapter • Audio line in, audio line out and microphone 	
Input voltage, AC	100...240V, autoranging	
Line frequency	50...60 Hz	
Power consumption, AC	10 A at 100V rms, 5 A at 240V rms	
Input voltage, DC	—	—
Power consumption, DC	—	—
Weight, approx	13.8 kg (30.36 lb)	14.0 kg (30.80 lb)
Dimensions (HxWxD), approx	360 x 170 x 381 mm (14.17 x 6.69 x 15.01 in.)	176 x 431 x 465 mm (6.93 x 16.97 x 18.31 in.)
Mount options	Machine mount	4U rack mount

Dimensions - Non-display Computers

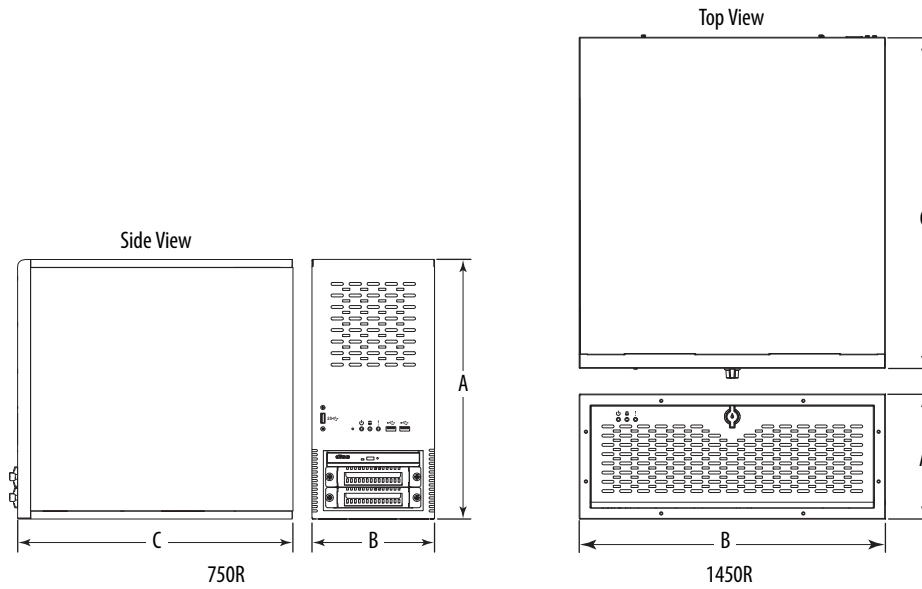

Table 19 - Dimensions - Non-display Computers

6177R Non-display Computers	Overall Height A	Overall Width B	Overall Depth C
750R	360 mm (14.17 in.)	170 mm (6.69 in.)	381 mm (15.01 in.)
1400R	176 mm (6.93 in.)	431 mm (16.97 in.)	465 mm (18.31 in.)

Compact Non-display Computers

These fanless computers provide a durable computer option for harsh environments and require less space than most computers. Designed without fans, the 6155F/6155R non-display computers come with either a mission-critical solid-state drive or a continuous-duty hard disk drive. Combine these features with the Windows Embedded Standard 2009 or Windows XP Professional operating system and you have the ideal platform for running visualization, control, or maintenance applications.



Table 20 - Environmental Specifications - 6155R/6155F Compact Non-display Computers

Attribute	6155R, 6155F
Temperature, operating	0...55 °C (32...131 °F)
Temperature, nonoperating	-20...60 °C (-4...140 °F)
Relative humidity	10...90% noncondensing
Vibration, operating	6155R 0.006 in. p-p 10...57 Hz, 1 g peak at 57...640 Hz 6155F 0.012 in. p-p 10...57 Hz, 2 g peak at 57...640 Hz
Vibration, nonoperating	0.012 in. p-p 10...57 Hz 2 g peak at 57...640 Hz
Shock, operating	15 g (1/2 sine, 11 ms)
Shock, nonoperating	30 g (1/2 sine, 11 ms)

Table 21 - Certifications - 6155R/6155F Compact Non-display Computers

Certification ⁽¹⁾	6155R, 6155F
cULus	UL/c-UL Listed per UL 60950-1 and CSA C22.2 No. 60950-1-03
CE	Marked for all applicable directives EMC 2004/108/EC LVD 2006/95/EC
RCM (formerly C-Tick)	Australian Radiocommunications Act, compliance with: AS/NZS CISPR 11; Industrial Emissions
RoHS	European China

(1) When marked. See the Product Certification link at <http://www.rockwellautomation.com/rockwellautomation/certification/overview.page> for declarations of conformity, certificates, and other certification details.

Table 22 - Technical Specifications - 6155R/6155F Compact Non-display Computers

Attribute	6155R	6155F						
Display type	Requires external monitor	Requires external monitor						
Processor	Celeron M 1 GHz Celeron M 1 GHz	No standard model Celeron M 1 GHz						
RAM	1 GB (2 GB, max) 2 GB (2 GB, max)	No standard model 2 GB (2 GB, max)						
Storage drive	100 GB SATA hard disk drive	32 GB SATA 2.5-in. solid-state drive						
Expansion slots	None	None						
CompactFlash Type II	2 slots, 1 internal, 1 external	2 slots, 1 internal, 1 external						
I/O	<table border="0"> <tr> <td>Standard</td> <td> <ul style="list-style-type: none"> • 1 PS/2 keyboard port • 1 PS/2 mouse port • 1 serial port • 1 Ethernet LAN port (1 Gb) • 4 USB 2.0 ports • 1 VGA port • Audio line out </td> <td>No standard model</td> </tr> <tr> <td>Performance</td> <td> <ul style="list-style-type: none"> • 1 PS/2 keyboard port • 1 PS/2 mouse port • 2 serial ports • 2 Ethernet LAN ports, 1 Gb each </td> <td> <ul style="list-style-type: none"> • 4 USB 2.0 ports • 1 VGA port • Audio line out </td> </tr> </table>	Standard	<ul style="list-style-type: none"> • 1 PS/2 keyboard port • 1 PS/2 mouse port • 1 serial port • 1 Ethernet LAN port (1 Gb) • 4 USB 2.0 ports • 1 VGA port • Audio line out 	No standard model	Performance	<ul style="list-style-type: none"> • 1 PS/2 keyboard port • 1 PS/2 mouse port • 2 serial ports • 2 Ethernet LAN ports, 1 Gb each 	<ul style="list-style-type: none"> • 4 USB 2.0 ports • 1 VGA port • Audio line out 	
Standard	<ul style="list-style-type: none"> • 1 PS/2 keyboard port • 1 PS/2 mouse port • 1 serial port • 1 Ethernet LAN port (1 Gb) • 4 USB 2.0 ports • 1 VGA port • Audio line out 	No standard model						
Performance	<ul style="list-style-type: none"> • 1 PS/2 keyboard port • 1 PS/2 mouse port • 2 serial ports • 2 Ethernet LAN ports, 1 Gb each 	<ul style="list-style-type: none"> • 4 USB 2.0 ports • 1 VGA port • Audio line out 						
Available operating systems	Windows XP Professional SP3	<ul style="list-style-type: none"> • Windows XP Professional SP3 • Windows Embedded Standard 2009 						
Supported software	Suite of FactoryTalk View software products and RSView [®] 32							
Input voltage, AC	100...240V AC autoranging, 47...63							
Power consumption, AC	35 W (0.64 A at 100V rms, 0.37 A at 240V rms)							
Input voltage, DC	9...36V DC							
Power consumption, DC	35 W (3.89 A at 9V DC, 0.97 A at 36V DC)							
Weight, approx	5 kg (11 lb)							
Dimensions (HxWxD), approx	115 x 172 x 158 mm (4.51 x 6.77 x 6.22 in.)							
Mount options	<ul style="list-style-type: none"> • DIN rail • Machine mount • VESA mount 							

Dimensions - Compact Non-display Computers

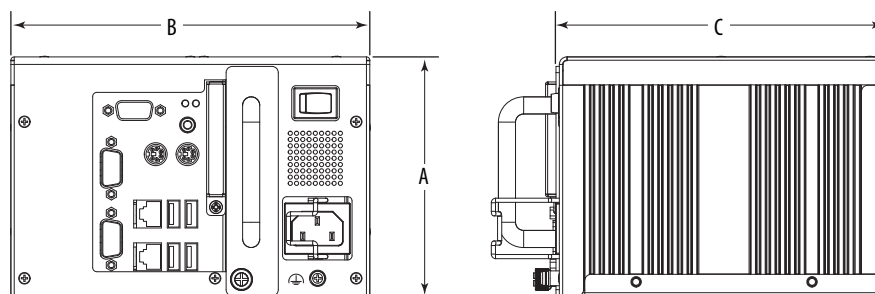

Table 23 - Dimensions - Compact Non-display Computers

6155R/F Compact Non-display Computer	Overall Height A	Overall Width B	Overall Depth C
200R	115 mm (4.51 in.)	172 mm (6.77 in.)	158 mm (6.22 in.) ⁽¹⁾

(1) Depth excludes handle and connectors.

Industrial Monitors

The Allen-Bradley LCD flat-panel industrial monitors are designed to operate in rugged industrial environments. With various mount configurations and interface options, the industrial monitors can meet the needs of visualization applications on the factory floor or in a control room.

Combine these monitors with any of the Allen-Bradley non-display computers to create a visualization, maintenance, control, or information-computing solution.

Table 24 - Industrial Monitors Comparison

Characteristic	Standard Monitors 6176M	Performance Monitors 6186M
Display	1550M: 15 in. color TFT 1750M: 17 in. color TFT 1950M: 19 in. color TFT	1200M: 12.1 in. color TFT 1500M: 15 in. color TFT 1700M: 17 in. color TFT 1900M: 19 in. color TFT
Available bezels	<ul style="list-style-type: none"> Aluminum Plastic 	<ul style="list-style-type: none"> Aluminum Stainless steel
Resolution	1550M: 1024 x 768, 16.7M colors 1750M/1950M: 1280 x 1024, 16.7M colors	1200M: 800 x 600, 256K colors 1500M: 1024 x 768, 16.7M colors 1700M/1900M: 1280 x 1024, 16.7M colors
Touch screen	Resistive antiglare RS-232 and USB inputs, model dependent	Resistive antiglare RS-232 and USB inputs, model dependent
Contrast ratio	1550M: 400:1 1750M/1950M: 800:1	1200M: 600:1 1500M: 400:1 1700M: 1000:1 1900M: 1300:1
Luminance	1550M: 350 cd/m ² (Nits) 1750M/1950M: 300 cd/m ² (Nits)	1500M/1700M: 450 cd/m ² (Nits) 1700M/1900M: 300 cd/m ² (Nits)
Video input signal	DVI and VGA (analog)	DVI and VGA (analog)
OS drivers, touch screen	<ul style="list-style-type: none"> Windows XP Pro⁽¹⁾ Windows Server 2003⁽¹⁾ Windows 7 Pro 32 bit⁽¹⁾ Windows 7 Pro 64 bit⁽²⁾ Windows Embedded 8.1 Industry Pro⁽²⁾ Windows Server 2008⁽²⁾ Windows Server 2012 Standard R2⁽²⁾ 	<ul style="list-style-type: none"> Windows XP Pro⁽³⁾ Windows Server 2003⁽³⁾ Windows 7 Pro 32 bit⁽³⁾ Windows 7 Pro 64 bit⁽⁴⁾ Windows Embedded 8.1 Industry Pro⁽⁴⁾ Windows Server 2008⁽⁴⁾ Windows Server 2012 Standard R2⁽⁴⁾
Power	AC or DC	AC or DC
Environmental conditions		
Temperature	0...45 °C (32...113 °F)	1200M/1500M: 0...55 °C (32...131 °F) 1700M/1900M: 0...50 °C (32...122 °F)
Shock (operating/nonoperating)	15 g/20 g	20 g/30 g
Vibration (operating/nonoperating)	1 g/2 g	2 g/2 g Rated Class 1 Division 2 for hazardous locations Preferred computer: 6181X hazardous location
Mount options	<ul style="list-style-type: none"> Panel VESA Bench/tabletop Rack (only 1900M) 	<ul style="list-style-type: none"> Panel Bench/tabletop Rack (only 1900M)

(1) For Series B or later monitors.

(2) For Series C or later monitors.

(3) For Series F or later monitors.

(4) For Series G or later monitors.



Performance Monitors

The 6186M performance monitors are best suited for special purpose environments, such as Class 1 Division 2, and Food and Beverage areas, providing excellent protection against heat, shock, and vibration.

Table 25 - Environmental Specifications - 6186M Performance Monitors

Attribute	1200M, 1500M, 1700M, 1900M
Temperature, operating	0...55 °C (32...131 °F)
1200M, 1500M	0...50 °C (32...122 °F)
1700M, 1900M	
Temperature, nonoperating	-20...60 °C (-4...140 °F)
Relative humidity	10...90% noncondensing
Vibration, operating	2 g at 10...640 Hz
Vibration, nonoperating	2 g at 10...640 Hz
Shock, operating	20 g (1/2 sine, 11 ms)
Shock, nonoperating	30 g (1/2 sine, 11 ms)
Enclosure ratings ⁽¹⁾	NEMA / UL 50 Type 1, 4, 4X, 12, and IEC IP66

(1) Applies only to panel-mounted monitors.

Table 26 - Certifications - 6186M Performance Monitors

Certification ⁽¹⁾	1200M, 1500M, 1700M, 1900M
cULus	UL Listed per UL 60950-1 UL 1604 Hazardous Locations, Class 1, Division 2 (when marked) on nameplate C-UL per CSA C22.2 No. 60950-1-03 UL 60079-15 Hazardous Locations, Class 1, Zone 2, Group IIC (when marked on nameplate) CSA Hazardous Locations per C22.2 No. 213 (when marked)
CE	Marked for all applicable directives
RCM (formerly C-Tick)	Australian Radiocommunications Act, compliance with: AS/NZS CISPR 11; Industrial Emissions

(1) When marked. See the Product Certification link at <http://www.rockwellautomation.com/rockwellautomation/certification/overview.page> for declarations of conformity, certificates, and other certification details.

Table 27 - Technical Specifications - 6186M Performance Monitors

Attribute	1200M	1500M	1700M	1900M
Display type	Color active-matrix TFT LCD			
Display size, diagonal	12.1 in. (307 mm)	15 in. (381 mm)	17 in. (432 mm)	19 in. (483 mm)
Display area (WxH)	246 x 185 mm (9.7 x 7.3 in.)	305 x 229 mm (12 x 9 in.)	338 x 270 mm (13.3 x 10.6 in.)	377 x 302 mm (14.8 x 11.9 in.)
Resolution, native mode	800 x 600 262K colors	1024 x 768 16.2M colors	1280 x 1024 16.7M colors	
Luminance	450 cd/m ² Nits		300 cd/m ² Nits	
Contrast ratio	600:1, typical	400:1, typical	1000:1, typical	1300:1, typical
Response time (rise and fall), max	35 ms	16 ms	8 ms	
Status indicator backlight lifetime	50,000 hours at 25 °C (77 °F)			
Bezel	Aluminum	<ul style="list-style-type: none"> Aluminum Stainless steel 		
Touch screen option	Resistive antiglare (RS-232 and USB inputs), model dependent			
OS drivers, touch screen	<ul style="list-style-type: none"> Windows XP Pro⁽¹⁾ Windows Server 2003⁽¹⁾ Windows 7 Pro 32 bit⁽¹⁾ Windows 7 Pro 64 bit⁽²⁾ Windows Embedded 8.1 Industry Pro⁽²⁾ Windows Server 2008⁽²⁾ Windows Server 2012 Standard R2⁽²⁾ 			
USB hub	(2) rear USB 2.0 ports, 500 mA per port (1) front USB 2.0 port, 500 mA (only on aluminum bezel models)			
Video input signal	DVI and VGA			
Video input connectors	HD-15 VGA for analog video signal DVI for digital video signal			
OSD controls (on rear)	<ul style="list-style-type: none"> Automatic screen setup (OSD) Brightness Contrast Horizontal position Vertical position Image lock Color balance Sync detect 			
Input voltage, AC	100...240V AC autoranging, 47...63, requires power adapter			
Power consumption	34 W	34 W	55 W	57 W
Input voltage, DC	9...36V DC (24V DC nominal)			
Weight, approx	4.4 kg (9.75 lb)	<ul style="list-style-type: none"> Aluminum: 7.3 kg (16.0 lb) Stainless steel: 8.6 kg (19.0 lb) 	<ul style="list-style-type: none"> Aluminum: 8.6 kg (19.0 lb) Stainless steel: 10.1 kg (22.25 lb) 	<ul style="list-style-type: none"> Aluminum: 10.2 kg (22.5 lb) Stainless steel: 11.9 kg (26.25 lb)
Dimensions (HxWxD), approx	260 x 340 x 61 mm (10.24 x 13.39 x 2.40 in.)	309 x 410 x 61 mm (12.17 x 16.14 x 2.40 in.)	356 x 452 x 61 mm (14.02 x 17.80 x 2.40 in.)	399 x 483 x 64 mm (15.71 x 19.02 x 2.52 in.)
Cutout dimensions (HxWxD)	238 x 318 mm (9.37 x 12.51 in.)	285.6 x 386.6 mm (11.24 x 15.22 in.)	329.5 x 424 mm (12.97 x 16.69 in.)	363.5 x 449.6 mm (14.31 x 17.70 in.)
Mount options	<ul style="list-style-type: none"> Panel Bench/tabletop DIN-rail for AC power adapter 			<ul style="list-style-type: none"> Panel Bench/tabletop DIN-rail for AC power adapter

(1) For Series F or later monitors.

(2) For Series G or later monitors.

Dimensions - Performance Monitors

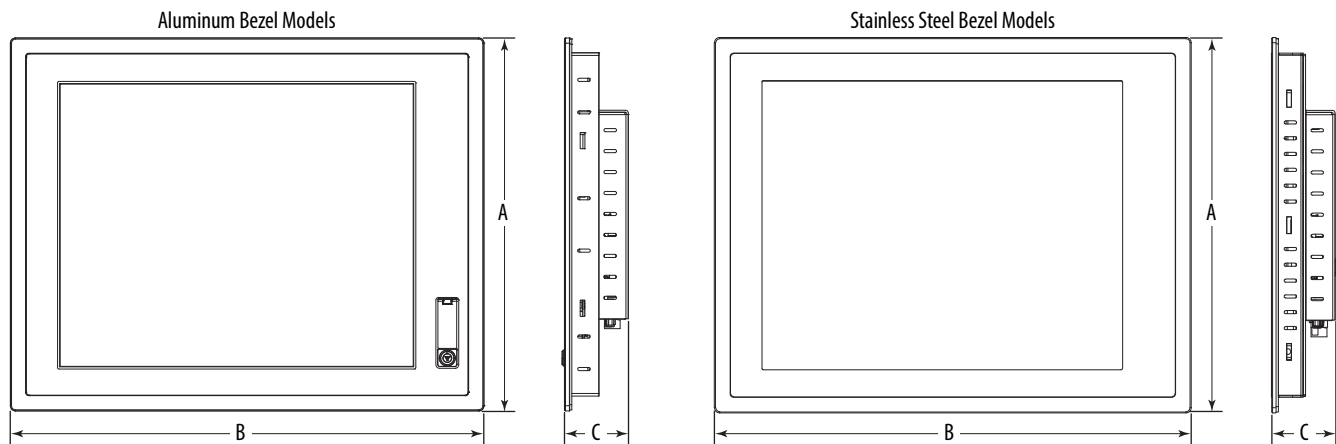

Table 28 - Dimensions - 6186M Performance Monitors

6186M Model	Height A	Width B	Depth C	Cutout Height	Cutout Width
1200M	260 mm (10.24 in.)	340 mm (13.39 in.)	61 mm (2.40 in.)	238 mm (9.37 in.)	318 mm (12.51 in.)
1500M	309 mm (12.17 in.)	410 mm (16.14 in.)		285.6 mm (11.24 in.)	386.6 mm (15.22 in.)
1700M	356 mm (14.02 in.)	452 mm (17.80 in.)		329.5 mm (12.97 in.)	424 mm (16.69 in.)
1900M	399 mm (15.71 in.)	483 mm (19.02 in.)	64 mm (2.52 in.)	363.5 mm (14.31 in.)	449.6 mm (17.70 in.)

Standard Monitors



The 6176M standard monitors are designed for less demanding environments, still providing industrial ratings for temperature, shock, and vibration.

Table 29 - Environmental Specifications - 6176M Standard Monitors

Attribute	1550M, 1750M, 1950M
Temperature, operating	0...45 °C (32...113 °F)
Temperature, nonoperating	-20...60 °C (-4...140 °F)
Relative humidity	10...90% noncondensing
Vibration, operating	1 g at 53...640 Hz
Vibration, nonoperating	2 g at 53...640 Hz
Shock, operating	15 g (1/2 sine, 11 ms)
Shock, nonoperating	20 g (1/2 sine, 11 ms)
Enclosure ratings ⁽¹⁾	NEMA Type 4, 12, IEC IP66

(1) Applies only to panel-mounted monitors.

Table 30 - Certifications - 6176M Standard Monitors

Certification ⁽¹⁾	1550M, 1750M, 1950M
UL/c-UL	Listed
CE	Marked for all applicable directives
RCM (formerly C-Tick)	Australian Radiocommunications Act, compliance with: AS/NZS CISPR 11; Industrial Emissions
RoHS	China RoHS, European RoHS

(1) When marked. See the Product Certification link at <http://www.rockwellautomation.com/rockwellautomation/certification/overview.page> for declarations of conformity, certificates, and other certification details.

Table 31 - Technical Specifications - 6176M Standard Monitors

Attribute	1550M	1750M	1950M
Display type	Color active-matrix TFT LCD		
Display size, diagonal	15 in. (381 mm)	17 in. (432 mm)	19 in. (483 mm)
Display area (WxH)	305 x 229 mm (12.0 x 9.0 in.)	338 x 270 mm (13.3 x 10.7 in.)	377 x 302 mm (14.8 x 11.9 in.)
Resolution	1024 x 768, 16.7M colors	1280 x 1024, 16.7M colors	
Luminance	350 cd/m ² Nits		
Contrast ratio, typical	400:1	800:1	
Response time, max	4 ms (fall) 12 ms (rise)	3 ms (fall) 6 ms (rise)	
Status indicator backlight lifetime	50,000 hours at 25 °C (77 °F)		
Available bezels	<ul style="list-style-type: none"> Plastic (reinforced steel) Aluminum alloy 		
Touch screen option	Resistive antiglare (RS-232 and USB inputs), model dependent		
Touch screen controller	Series A and B Series C Panjit eGalax_eMPIA Technology Inc (EETI)		
OS drivers, touch screen	Series A and B Series C <ul style="list-style-type: none"> Windows XP Pro Windows Server 2003 (32 bit) Windows 7 Pro (32 bit) Windows XP Pro Windows Server 2003 (32 bit) Windows 7 Pro (32 bit and 64 bit) Windows Embedded 8.1 Industry Pro Windows Server 2008 (64 bit) Windows Server 2012 Standard R2 		
USB hub	(2) USB 2.0, 500 mA per port		
Video input signal	VGA and DVI (system auto-select)		
Video input connectors	HD-15 VGA for analog video signal DVI for digital video signal		
OSD controls	Rear controls: automatic screen setup (OSD), brightness, contrast, horizontal position, vertical position, image lock, color balance, sync detect		
Input voltage, AC	90...264V AC autoranging, 47...63		
Power consumption	2.0 A at 24 W	3 A at 36 W	3.5 A at 42 W
Input voltage, DC	12V DC, power adapter required		
Weight, approx	VESA mount Panel mount 3.1 kg (6.82 lb) 4.1 kg (9.02 lb)	4.6 kg (10.12 lb) 5.7 kg (12.54 lb)	6.0 kg (13.20 lb) 7.5 kg (16.50 lb)
Dimensions (HxWxD), approx	VESA mount Panel mount 282.6 x 383.6 x 50.0 mm (11.0 x 15.0 x 2.0 in.) 309 x 410 x 50 mm (12.2 x 16.1 x 2.0 in.)	326.5 x 421.0 x 53.0 mm (12.9 x 16.6 x 2.1 in.) 356 x 452 x 53 mm (14.0 x 17.8 x 2.1 in.)	357 x 444 x 58 mm (14.1 x 17.5 x 2.3 in.) 399.3 x 482.6 x 58.0 mm (15.7 x 19.0 x 2.3 in.)
Dimensions cutout (HxW), approx	Panel mount 285.6 x 386.6 mm (11.24 x 15.22 in.)		329.5 x 424.0 mm (12.97 x 16.69 in.)
Mount options	<ul style="list-style-type: none"> VESA Panel Bench/tabletop 	<ul style="list-style-type: none"> VESA Panel Bench/tabletop 	<ul style="list-style-type: none"> VESA Panel Rack⁽¹⁾ Bench/tabletop

(1) Installs in a standard 19-in. rack.

Dimensions - Standard Monitors

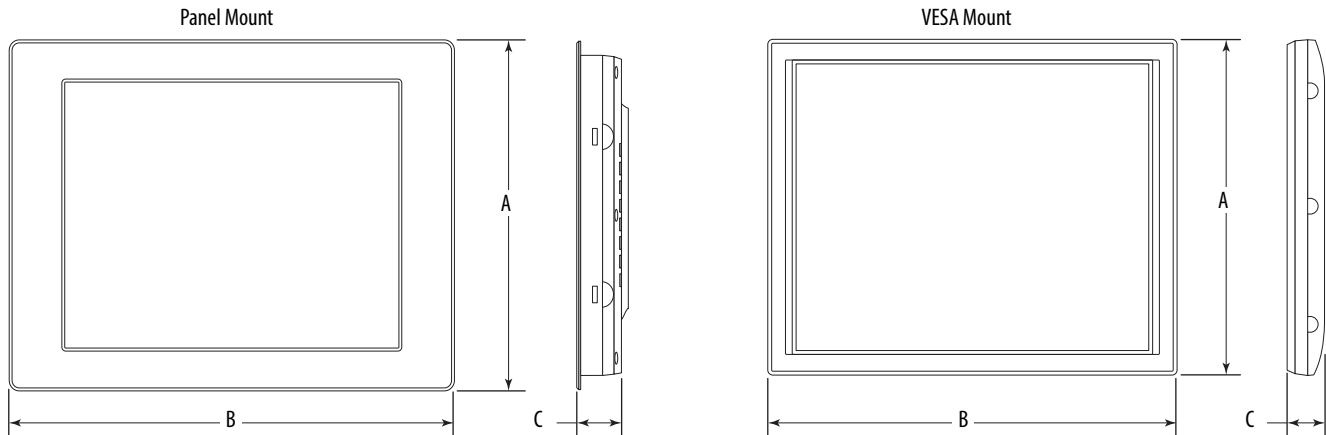

Table 32 - Dimensions - 6176M Standard Industrial Monitors

6176M Model	Height A	Width B	Depth C	Cutout Height	Cutout Width
1550M					
Panel mount	309 mm (12.3 in.)	410 mm (16.1 in.)	50 mm (2.0 in.)	285.6 mm (11.24 in.)	386.6 mm (15.22 in.)
VESA mount	282.6 mm (11.0 in.)	383.6 mm (15.0 in.)	50 mm (2.0 in.)	—	—
1750M					
Panel mount	356 mm (14.0 in.)	452 mm (17.8 in.)	53 mm (2.1 in.)	329.5 mm (12.97 in.)	424 mm (16.69 in.)
VESA mount	326.5 mm (12.9 in.)	421 mm (16.6 in.)	53 mm (2.1 in.)	—	—
1950M					
Panel mount	399.3 mm (15.7 in.)	482.6 mm (19.0 in.)	58 mm (2.3 in.)	363.5 mm (14.31 in.)	449.6 mm (17.70 in.)
VESA mount	357 mm (14.1 in.)	444 mm (17.5 in.)	58 mm (2.3 in.)	—	—

HMI Software

The Allen-Bradley industrial computers support the full suite of Rockwell Software solutions, including Integrated Architecture and FactoryTalk View software. Combine this hardware and software to assure comprehensive application support from an industry leader.

FactoryTalk View performance and visibility HMI software are designed with a common look, feel, and navigation to help speed HMI development and training time. The visualization strategy combines Rockwell Automation expertise in industrialized personal computer hardware with Rockwell Software supervisory control software.

For a complete list of available HMI software, visit <http://www.rockwellautomation.com/rockwellsoftware>.

FactoryTalk View Machine Edition Software

FactoryTalk View Machine Edition (ME) software supports both open and embedded operator interface solutions for monitoring and controlling individual machines or small processes. This software features a consistent operator interface across multiple platforms, including Microsoft Windows 8.1, 8, 7, Vista, XP, Server, and Embedded Compact solutions. FactoryTalk View ME software consists of a design and runtime environment.

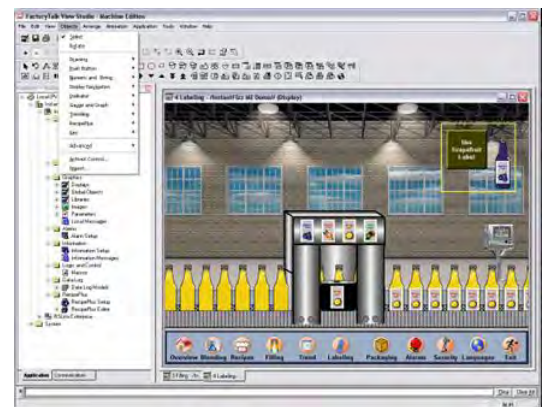

FactoryTalk View Studio Software

FactoryTalk View Studio software is the design environment to create and test HMI applications, including graphic displays, trends, alarms, and real-time animation. Runtime files can be generated to run on a PanelView™ Plus terminal or industrial computer.

FactoryTalk View ME Station

FactoryTalk View ME Station is the runtime environment for HMI applications. FactoryTalk View ME Station is automatically installed and activated on PanelView Plus terminals. FactoryTalk View ME activation is required when running HMI applications on industrial computers.

FactoryTalk View ME offers many advantages:

- Alarms to alert operators to conditions that require immediate action
- Security to restrict operator access to specific displays
- RecipePlus for machine or process recipe management
- Display text supports up to 20 languages per application, so operators can switch language at runtime
- Global and predefined objects are time and memory savers
- Studio 5000® and Studio 5000 Logix Designer® process faceplates
- Ability to convert runtime application to design application
- Transfer parameters for reuse in displays and design efficiency

FactoryTalk View Site Edition Software

FactoryTalk View Site Edition (SE) software is an HMI for developing supervisory-level monitoring and control applications. Its architecture is scalable to a wide range of applications, from standalone, one-server/one-client applications to multi-server/multi-client applications. Runtime servers and clients are supported for customers to develop and deploy a multi-server/multi-client application.

FactoryTalk View SE applications are created and tested within the FactoryTalk View Studio design environment:

- Share data and seamless integration with other FactoryTalk enabled products. The FactoryTalk Services Platform provides common services, such as security, alarms, and diagnostics across products.
- Optimize plant communication with FactoryTalk Live Data and premier connectivity to Allen-Bradley controllers.
- Access tag information directly in the controller to eliminate HMI tags.
- Configure an application from anywhere on the network to change a running system with a remote, multi-user configuration capability.
- Define graphic displays once and reference them throughout a distributed system.
- Provide an audit trail of operator and alarm information in a centralized log database.
- Customize the operator experience by using client-side VBA and the exposed graphics object model.



FactoryTalk View Studio Software

FactoryTalk View Machine Edition and FactoryTalk View Site Edition share a common design environment that is called FactoryTalk View Studio to create applications. The ability to edit and reuse projects in FactoryTalk View Studio improves portability between embedded machine and supervisory HMI systems.

With FactoryTalk View software, all products in the suite are built on the same integrated, scalable architecture. Application developers can import entire machine-level applications into supervisory-level applications or drag individual components and drop them right into supervisory projects, which saves development time and reduces Engineering and training costs.

Plus, help protect your current HMI investments by importing PanelBuilder®32 (PanelView) applications into FactoryTalk View ME software and RSVIEW32 applications into FactoryTalk View SE software.

With FactoryTalk View Studio software, you can do the following:

- Configure one operator station or an entire distributed application from one location.
- Access tags from OPC servers throughout the system via a tag browser that presents direct controller tags and HMI tags in a logical hierarchy.
- Remotely configure RSLinx® and FactoryTalk View SE servers.
- Create displays by using a full-featured graphics editor.
- Define display text in multiple languages, so operators can switch language at runtime.
- Use pre-engineered faceplates to interface with the process control functions in the Logix controllers.

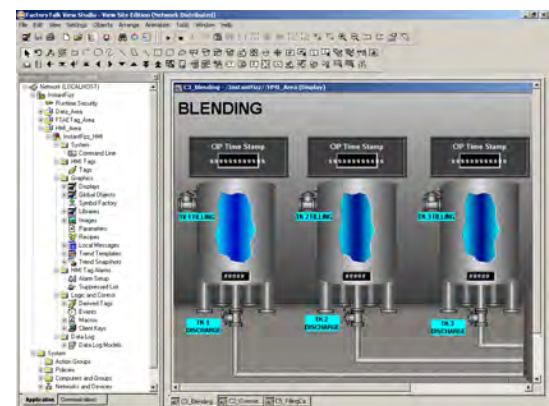

FactoryTalk ViewPoint Software

An add-on to FactoryTalk View SE software and PanelView Plus 6 or 7 terminals, FactoryTalk ViewPoint software provides on-demand access to important information about your plant or process from a Web Browser. Plant managers, supervisors, OEMs, system integrators, and other key stakeholders can now access, monitor, and interact with plant floor operations from virtually any location. The thin-client configuration means no client software to install and maintain, which lowers total cost of ownership:

- Fully scalable, animated web applications viewable in the office, at home, or on the road.
- Gives managers, OEMs, and system integrators read and write capability to both view and control real-time plant floor operations by logging in to an internet browser.
- Provides read and write capabilities to monitor operations.
- Gain fast access to real-time information with a standard Web Browser.
- Supports multiple browsers and client devices for increased flexibility.
- Lets FactoryTalk View projects be web-enabled without any necessary application changes.
- Monitor and control HMI applications, perform diagnostics, and provide remote support.



Software Comparison

Table 33 - Software Technology

Customer Requirements	FactoryTalk View Site Edition (SE)	FactoryTalk View Machine Edition (ME)	RSView32
Operating systems (32 bit)	<ul style="list-style-type: none"> • Windows 8.1 Professional • Windows 8.1 Enterprise • Windows 8 Professional • Windows 8 Enterprise • Windows 7 Professional • Windows 7 Professional SP1 • Windows 7 Enterprise SP1 • Windows Server 2008 Standard SP2 • Windows Vista SP2 • Windows XP Professional SP3 • Windows Server 2003 R2 Standard SP2 		<ul style="list-style-type: none"> • Windows 7 Professional • Windows XP Professional SP1 or later • Windows Server 2008 Standard SP2 • Windows Vista Business SP1 or later • Windows Vista Home Basic SP1 or later • Windows Server 2003 R2 Standard SP2 • Windows Server 2000 SP4 • Windows 2000 Professional SP4
Operating systems (64 bit)	<ul style="list-style-type: none"> • Windows 8.1 Professional • Windows 8.1 Enterprise • Windows 8 Professional • Windows 8 Enterprise • Windows 7 Professional • Windows 7 Professional SP1 • Windows 7 Enterprise SP1 • Windows 7 Ultimate SP1 • Windows Server 2012 Standard • Windows Server 2012 R2 Standard • Windows Server 2008 R2 Standard SP1 • Windows Server 2008 R2 Enterprise SP1 • Windows Server 2008 Standard SP2 • Windows Vista SP2⁽¹⁾ • Windows XP Professional SP3 • Windows Server 2003 R2 Standard SP2 		
Embedded platforms		✓	
Windows domain security	✓	✓	✓
OPC/ActiveX	✓	✓	✓
FactoryTalk enabled	✓	✓	
Server-side VBA			✓
Client-side VBA	✓		

(1) You can only use Windows Vista to host stand-alone or distribution applications that run on a single computer, or run FactoryTalk View SE Client or FactoryTalk View Studio software that connect to an application hosted on the same computer or a remote computer.

Table 34 - Software Architecture

Customer Requirements	FactoryTalk View SE		FactoryTalk View ME	RSView32
Primary application	Supervisory level: single station up to multiple server, multiple client		Machine level: single station	Supervisory level; single station up to single server, multiple client
Tag-based HMI	✓		✓	✓
Direct reference capability	✓		✓	
	Network (Distributed)	Local		
Max Number of servers/clients	10/50			1/20
FactoryTalk ViewPoint	✓	✓	✓ ⁽¹⁾	✓
RSView32 WebServer				✓
Thin clients (terminal services)	✓			✓
Multi-user development	✓			
Remote configuration at runtime	✓			
Redundancy - data server	✓			
Redundancy - HMI server	✓			Active display

(1) Supported only on PanelView Plus 6 and PanelView Plus 7 terminals.

Table 35 - Software Features

Customer Requirements	FactoryTalk View SE	FactoryTalk View ME	RSView32
Animation - visibility, color, fill, horizontal and vertical position, width, height, rotation, horizontal and vertical slider, and more	And touch	No touch animation	And touch
Alarms	<ul style="list-style-type: none"> FactoryTalk alarms and events HMI alarms Digital and analog Defined alarm severities Alarm log 	<ul style="list-style-type: none"> Tag-based (from controller) Alarm log 	<ul style="list-style-type: none"> Tag-based Digital and analog Definable alarm severities Alarm log
Data logging	<ul style="list-style-type: none"> 20 data log models per project Each with up to 10,000 tags Log to ODBC or proprietary database 	<ul style="list-style-type: none"> 1 data log model per project With up to 100 tags 1,000K records max Export to dbf 	<ul style="list-style-type: none"> 20 plus data log models per project Each with up to 10,000 tags Log to ODBC or proprietary database
Trend version	TrendX 4.0	TrendX 4.0 subset	TrendX 3.1 and native
Security	<ul style="list-style-type: none"> Assigned to tags, graphic displays, macros, commands, OLE objects Local or Windows security 	<ul style="list-style-type: none"> Display-based Local or Windows security 	<ul style="list-style-type: none"> Assigned to tags, graphic displays, macros, commands, OLE objects Local or Windows security
Other features	<ul style="list-style-type: none"> Test run macros Derived tags Event detector 	<ul style="list-style-type: none"> Test run macros Derived tags S/B test run macros-derived tags 	<ul style="list-style-type: none"> Test run macros Derived tags Event detector
Price model	<ul style="list-style-type: none"> Display-based Multiple levels 	<ul style="list-style-type: none"> Included with PanelView Plus 7 or display-based Multiple levels for FactoryTalk View ME Station 	<ul style="list-style-type: none"> Tag-based Multiple levels

Table 36 - FactoryTalk View Site Edition (SE) Software

Installation Type	Software Installed	Hardware Requirements (min)
Operator workstation	FactoryTalk View SE Client or FactoryTalk View SE Station	<ul style="list-style-type: none"> Intel Core 2 Duo 2 GB memory
Engineering workstation	<ul style="list-style-type: none"> FactoryTalk View Studio Enterprise RSLinx Classic RSLinx Enterprise Studio5000 	<ul style="list-style-type: none"> Intel Core 2 Duo 4 GB memory
Application server	<ul style="list-style-type: none"> FactoryTalk View SE Server FactoryTalk View Studio Enterprise FactoryTalk View Alarms and Tags based Server RSLinx Enterprise Data Server with FactoryTalk alarms and events enabled 	Smaller system: <ul style="list-style-type: none"> Intel Core 2 Duo 2 GB memory Medium to larger systems: <ul style="list-style-type: none"> Quad core Intel Xeon 4 GB memory

Table 37 - FactoryTalk View SE Software

Media Cat. No.	Electronic Download Cat. No.	Description ⁽¹⁾
To choose your preferred language, replace the xx in the catalog number with EN for English, DE for German, FR for French, JP for Japanese, or ZH for Chinese.		
9701-VWSTxxE	9701-VWSTxxW	FactoryTalk View Studio for FactoryTalk View Enterprise - configuration software to develop and test machine level and supervisory level HMI applications
9701-VWSCWAxxE	9701-VWSCWAxxW	FactoryTalk View SE Client - software to view and interact with FactoryTalk View SE Servers ⁽²⁾
9701-VWSCRAxxE	9701-VWSCRAxxW	FactoryTalk View SE View Client - provides read-only capabilities
9701-VWSB015AxxE	9701-VWSB015AxxW	FactoryTalk View SE Station 15 display
9701-VWSB025AxxE	9701-VWSB025AxxW	FactoryTalk View SE Station 25 display
9701-VWSB100AxxE	9701-VWSB100AxxW	FactoryTalk View SE Station 100 display
9701-VWSB250AxxE	9701-VWSB250AxxW	FactoryTalk View SE Station 250 display
9701-VWSB000AxxE	9701-VWSB000AxxW	FactoryTalk View SE Station unlimited display
9701-VWSS025LxxE	9701-VWSS025LxxW	FactoryTalk View SE Server 25 display with RSLinx Enterprise
9701-VWSS100LxxE	9701-VWSS100LxxW	FactoryTalk View SE Server 100 display with RSLinx Enterprise
9701-VWSS250LxxE	9701-VWSS250LxxW	FactoryTalk View SE Server 250 display with RSLinx Enterprise
9701-VWSS000LxxE	9701-VWSS000LxxW	FactoryTalk View SE Server unlimited display with RSLinx Enterprise

(1) FactoryTalk View Station and FactoryTalk View SE Server include RSLinx Enterprise and RSLinx Classic software, version 3.70.

(2) FactoryTalk View SE Server stores HMI project components and serves to clients, for example, graphic displays.

Table 38 - FactoryTalk ViewPoint Software

Media Cat. No. ⁽¹⁾	Electronic Download Cat. No.	Description ⁽²⁾
9522-VWP01RENE	9522-VWP01RENEW	FactoryTalk ViewPoint 1-client system
9522-VWP03RENE	9522-VWP03RENEW	FactoryTalk ViewPoint 3-client system
9522-VWP05RENE	9522-VWP05RENEW	FactoryTalk ViewPoint 5-client system
9522-VWP10RENE	9522-VWP10RENEW	FactoryTalk ViewPoint 10-client system
9522-VWP25RENE	9522-VWP25RENEW	FactoryTalk ViewPoint 25-client system
9522-VWP50RENE	9522-VWP50RENEW	FactoryTalk ViewPoint 50-client system

(1) Order any of these catalog numbers to use FactoryTalk ViewPoint software with FactoryTalk View SE network or local applications.

(2) FactoryTalk ViewPoint server and one client access license are included with the purchase of a PanelView Plus 6 or PanelView Plus 7 terminal. No other catalog numbers are required to use FactoryTalk ViewPoint software with PanelView Plus 6 or PanelView Plus 7 terminals.

Table 39 - FactoryTalk View Machine Edition (ME) Software

Media Cat. No.	Electronic Download Cat. No.	Description
To choose your preferred language, replace the xx in the catalog number with EN for English, DE for German, FR for French, JP for Japanese, or ZH for Chinese.		
9701-VWSTMxxE	9701-VWSTMxxW	FactoryTalk View Studio for Machine Edition - configuration software to develop and test machine level HMI applications. FactoryTalk View Machine Edition includes RSLinx Enterprise and KEPServer Enterprise software.

Table 40 - FactoryTalk View ME Station

Media Cat. No.	Electronic Download Cat. No.	Description ^{(1) (2)}
To choose your preferred language, replace the xx in the catalog number with EN for English, DE for German, FR for French, JP for Japanese, or ZH for Chinese.		
9701-VWVR015AxxE	9701-VWVR015AxxW	FactoryTalk View ME Station Runtime 15 displays
9701-VWVR030AxxE	9701-VWVR030AxxW	FactoryTalk View ME Station Runtime 30 displays
9701-VWVR075AxxE	9701-VWVR075AxxW	FactoryTalk View ME Station Runtime 75 displays
9701-VWVR250AxxE	9701-VWVR250AxxW	FactoryTalk View ME Station Runtime 250 displays
9701-VWVR500AxxE	9701-VWVR500AxxW	FactoryTalk View ME Station Runtime 500 displays

(1) FactoryTalk View Machine Edition Station is the runtime environment where FactoryTalk View ME projects created with FactoryTalk View Studio software are run on any computer with a Windows operating system. See [page 30](#) for the available Windows operating systems.

(2) FactoryTalk View ME Station runtime is included with all PanelView Plus 6 or PanelView Plus 7 terminals.

Table 41 - RSVIEW32 Software

Media Cat. No.	Electronic Download Cat. No.	Description ⁽¹⁾
9301-2SE3104	9301-2SE3104W	RSView32 Runtime 150 with RSLinx Classic single node
9301-2SE3103	9301-2SE3103W	RSView32 Runtime 150 with RSLinx Classic OEM, which includes 9301-2SE3100 RSVIEW32 Runtime 150 and 9355-WABSNENE RSLinx Classic single node
9301-2SE3100	9301-2SE3100W	RSView32 Runtime 150 - 150 tag database and standalone runtime
9301-2SE2104	9301-2SE2104W	RSView32 Works 150 with RSLinx Classic single node
9301-2SE2103	9301-2SE2103W	RSView32 Works 150 with RSLinx Classic OEM, which includes 9301-2SE2100 RSVIEW32 Works 150 and 9355-WABSNENE RSLinx Classic single node
9301-2SE2100	9301-2SE2100W	RSView32 Works 150 - 150 tag database that includes development and one embedded runtime
9301-2SE3204	9301-2SE3204W	RSView32 Runtime 300 with RSLinx Classic single node
9301-2SE3203	9301-2SE3203W	RSView32 Runtime 300 with RSLinx Classic OEM, which includes 9301-2SE3203 RSVIEW32 runtime 300 and 9355-WABSNENE RSLinx Classic single node
9301-2SE3200	9301-2SE3200W	RSView32 Runtime 300 - 300 tag database and standalone runtime
9301-2SE2204	9301-2SE2204W	RSView32 Works 300 with RSLinx Classic single node
9301-2SE2203	9301-2SE2203W	RSView32 Works 300 with RSLinx Classic OEM, which includes 9301-2SE2200 RSVIEW32 Works 300 and 9355-WABSNENE RSLinx Classic single node
9301-2SE2200	9301-2SE2200W	RSView32 Works 300 - 300 tag database that includes development and one embedded runtime
9301-2SE3304	9301-2SE3304W	RSView32 Runtime 1500 with RSLinx Classic single node
9301-2SE3303	9301-2SE3303W	RSView32 Runtime 1500 with RSLinx Classic OEM, which includes 9301-2SE3300 RSVIEW32 runtime 1500 and 9355-WABSNENE RSLinx Classic single node
9301-2SE3300	9301-2SE3300W	RSView32 Runtime 1500 - 1500 tag database and standalone runtime
9301-2SE2304	9301-2SE2304W	RSView32 Works 1500 with RSLinx Classic single node
9301-2SE2303	9301-2SE2303W	RSView32 Works 1500 with RSLinx Classic OEM, which includes 9301-2SE2300 RSVIEW32 Works 1500 and 9355-WABSNENE RSLinx Classic single node
9301-2SE2300	9301-2SE2300W	RSView32 Works 1500 - 1500 tag database that includes development and one embedded runtime
9301-2SE3353	9301-2SE3353W	RSView32 Runtime 5000 with RSLinx Classic OEM, which includes 9301-2SE3500 RSVIEW32 runtime 5000 and 9355-WABSNENE RSLinx Classic single node
9301-2SE3350	9301-2SE3350W	RSView32 Runtime 5000 - 5000 tag database and standalone runtime
9301-2SE2353	9301-2SE2353W	RSView32 Works 5000 with RSLinx Classic OEM, which includes 9301-2SE2350 RSVIEW32 Works 5000 and 9355-WABSNENE RSLinx Classic single node
9301-2SE2350	9301-2SE2350W	RSView32 Works 5000 - 5000 tag database that includes development and one embedded runtime
9301-2SE3403	9301-2SE3403W	RSView32 Runtime 32K with RSLinx Classic OEM, which includes 9301-2SE3400 RSVIEW32 runtime 2K and 9355-WABSNENE RSLinx Classic single node
9301-2SE3400	9301-2SE3400W	RSView32 Runtime 32K - 32,000 tag database and standalone runtime
9301-2SE2403	9301-2SE2403W	RSView32 Works 32K with RSLinx Classic OEM, which includes 9301-2SE2400 RSVIEW32 Works 32K and 9355-WABSNENE RSLinx Classic single node

Table 41 - RSView32 Software (continued)

Media Cat. No.	Electronic Download Cat. No.	Description ⁽¹⁾
9301-2SE2400	9301-2SE2400W	RSView32 Works 32K - 32,000 tag database that includes development and one embedded runtime
9301-2SE3503	9301-2SE3503W	RSView32 Runtime 100K with RSLinx Classic OEM, which includes 9301-2SE3500 RSView32 runtime 100K and 9355-WABSNENE RSLinx Classic single node
9301-2SE3500	9301-2SE3500W	RSView32 Runtime 100K - 100,000 tag database and standalone runtime
9301-2SE2503	9301-2SE2503W	RSView32 Works 100K with RSLinx Classic OEM, which includes 9301-2SE2500 RSView32 Works 100K and 9355-WABSNENE RSLinx Classic single node
9301-2SE2500	9301-2SE2500W	RSView32 Works 100K - 100,000 tag database that includes development and one embedded runtime
9301-RSVWSENE	9301-RSVWSENW	RSView32 WebServer
9301-MSGRPROENE	9301-MSGRPROENW	RSView32 Messenger Pro

(1) Monitors, controls, and acquires data.

Table 42 - RSView32 Active Display System

Media Cat. No.	Electronic Download Cat. No.	Description ⁽¹⁾
9305-RSVADSENE	9305-RSVADSENW	RSView32 Active Display Server that includes one active display server (no clients)
9305-ADSGWENE	9305-ADSGWENW	RSView32 Active Display Server with FactoryTalk Gateway, which includes one active display server (no clients) and 9355-WABGWENE RSLinx Classic Gateway
9305-RSVADFCENE	9305-RSVADFCENW	RSView32 Active Display Floating Client that includes one client with server-side activation
9305-RSVADDCENE	9305-RSVADDCENW	RSView32 Active Display Dedicated Client that includes one client with client-side activation
9305-RSVADFCENE	9305-RSVADFCENW	RSView32 Active Display Floating View Client that includes one view-only client with server-side activation

(1) Client/Server Enhancement to RSView32.

Table 43 - RSView32 Languages

Media Cat. No.	Electronic Download Cat. No.	Description
To choose your preferred language, replace the xx in the catalog number with EN for English, DE for German, ES for Spanish, FR for French, IT for Italian, JP for Japanese, KO for Korean, PT for Portuguese, and ZH for Chinese.		
9301-2SE2100xxE	9301-2SE2100xxW	RSView32 Works 150
9301-2SE2103xxE	9301-2SE2103xxW	RSView32 Works 150 with RSLinx Classic bundle
9301-2SE2200xxE	9301-2SE2200xxW	RSView32 Works 300
9301-2SE2203xxE	9301-2SE2203xxW	RSView32 Works 300 with RSLinx Classic bundle
9301-2SE2300xxE	9301-2SE2300xxW	RSView32 Works 1500
9301-2SE2303xxE	9301-2SE2303xxW	RSView32 Works 1500 with RSLinx Classic bundle
9301-2SE2350xxE	9301-2SE2350xxW	RSView32 Works 5K
9301-2SE2353xxE	9301-2SE2353xxW	RSView32 Works 5K with RSLinx Classic bundle
9301-2SE2400xxE	9301-2SE2400xxW	RSView32 Works 32K
9301-2SE2403xxE	9301-2SE2403xxW	RSView32 Works 32K with RSLinx Classic bundle
9301-2SE2500xxE	9301-2SE2500xxW	RSView32 Works 100K
9301-2SE2503xxE	9301-2SE2503xxW	RSView32 Works 100K with RSLinx Classic bundle
9301-2SE3100xxE	9301-2SE3100xxW	RSView32 Runtime 150
9301-2SE3103xxE	9301-2SE3103xxW	RSView32 Runtime 150 with RSLinx Classic bundle
9301-2SE3200xxE	9301-2SE3200xxW	RSView32 Runtime 300
9301-2SE3203xxE	9301-2SE3203xxW	RSView32 Runtime 300 with RSLinx Classic bundle
9301-2SE3300xxE	9301-2SE3300xxW	RSView32 Runtime 1500
9301-2SE3303xxE	9301-2SE3303xxW	RSView32 Runtime 1500 with RSLinx Classic bundle
9301-2SE3350xxE	9301-2SE3350xxW	RSView32 Runtime 5K
9301-2SE3353xxE	9301-2SE3353xxW	RSView32 Runtime 5K with RSLinx Classic bundle

Table 43 - RSView32 Languages (continued)

Media Cat. No.	Electronic Download Cat. No.	Description
9301-2SE3400xxE	9301-2SE3400xxW	RSView32 Runtime 32K
9301-2SE3403xxE	9301-2SE3403xxW	RSView32 Runtime 32K with RSLinx Classic bundle
9301-2SE3500xxE	9301-2SE3500xxW	RSView32 Runtime 100K
9301-2SE3503xxE	9301-2SE3503xxW	RSView32 Runtime 100K with RSLinx Classic bundle
9305-RSVADSxxE	9305-RSVADSxxW	RSView32 Active Display Server
9305-RSVADFCxxE	9305-RSVADFCxxW	RSView32 Active Display Floating Client
9305-RSVADDCxxE	9305-RSVADDCxxW	RSView32 Active Display Dedicated Client
9305-RSVADFVCxxE	9305-RSVADFVCxxW	RSView32 Active Display Floating View Client

Table 44 - Third-party Connectivity

Media Cat. No.	Electronic Download Cat. No.	Description
9301-OPCSRVE	9301-OPCSRVENW	KEPServer Enterprise for RSView32, FactoryTalk View Site Edition, and FactoryTalk View Machine Edition

Additional Resources

These documents contain more information about related products from Rockwell Automation.

Resource	Description
Visualization Solutions Selection Guide, VIEW-SG001	Provides an overview of the visualization products including catalog number selections offered by Rockwell Automation.
Integrated Display Computers User Manual, publication 6181P-UM002	Provides information on installing, making connections, operating, and troubleshooting the Series E (standard) computers.
Integrated Display Industrial Computers User Manual, publication 6181P-UM003	Provides information on installing, making connections, operating, and troubleshooting the Series F (performance and advanced) computers.
Integrated Display Industrial Computers with Keypad User Manual, publication 6180P-UM001	Provides information on installing, making connections, operating, and troubleshooting the computer.
Industrial Computers for Hazardous Locations User Manual, publication 6181X-UM001	Provides information and guidelines for installing, operating, and troubleshooting this computer in hazardous locations and extreme temperature environments.
Compact Non-display Industrial Computers User Manual, publication 6155R-UM002	Provides information on installing, making connections, operating, and troubleshooting the computer.
Non-display Industrial Computers User Manual, publication 6177R-UM002	Provides information on installing, making connections, operating, and troubleshooting the 750R and 1450R non-display computers.
Cloning Utility Technical Data, publication 6000-TD002	Provides information on how to create and restore a backup image of your computer's hard disk drive.
Diagnostic Utility for Industrial Computers, publication 6000-TG001	Provides information on how to diagnose hardware issues with industrial computers.
EFW and HORM Configuration Utility Technical Data, publication 6000-TD003	Provides information on how to configure Enhanced Write Filter (EFW) and Hibernate Once, Restore Many (HORM) features for computers with the Windows Embedded Standard 2009 operating system.
6186M Performance Monitors User Manual, publication 6186M-UM002	Provides details about how to install and mount the monitors, configure video setup, and troubleshoot the monitors.
6176M Standard Monitors User Manual, publication 6176M-UM001	Provides details about how to install and mount the monitors, configure video setup, and troubleshoot the monitors.

You can view or download publications at <http://www.rockwellautomation.com/literature>. To order paper copies of technical documentation, contact your local Allen-Bradley distributor or Rockwell Automation sales representative.

Important User Information

Read this document and the documents listed in the additional resources section about installation, configuration, and operation of this equipment before you install, configure, operate, or maintain this product. Users are required to familiarize themselves with installation and wiring instructions in addition to requirements of all applicable codes, laws, and standards.

Activities including installation, adjustments, putting into service, use, assembly, disassembly, and maintenance are required to be carried out by suitably trained personnel in accordance with applicable code of practice.

If this equipment is used in a manner not specified by the manufacturer, the protection provided by the equipment may be impaired.

In no event will Rockwell Automation, Inc. be responsible or liable for indirect or consequential damages resulting from the use or application of this equipment.

The examples and diagrams in this manual are included solely for illustrative purposes. Because of the many variables and requirements associated with any particular installation, Rockwell Automation, Inc. cannot assume responsibility or liability for actual use based on the examples and diagrams.

No patent liability is assumed by Rockwell Automation, Inc. with respect to use of information, circuits, equipment, or software described in this manual.

Reproduction of the contents of this manual, in whole or in part, without written permission of Rockwell Automation, Inc., is prohibited.

Documentation Feedback

Your comments will help us serve your documentation needs better. If you have any suggestions on how to improve this document, complete this form, publication [RA-DU002](#), available at <http://www.rockwellautomation.com/literature/>.

Rockwell Automation maintains current product environmental information on its website at <http://www.rockwellautomation.com/rockwellautomation/about-us/sustainability-ethics/product-environmental-compliance.page>.

Allen-Bradley, FactoryTalk, Integrated Architecture, PanelBuilder, PanelView, RSLinx, RSVIEW, Studio 5000, Studio 5000 Logix Designer, Rockwell Software, Rockwell Automation, and LISTEN. THINK. SOLVE are trademarks of Rockwell Automation, Inc.

Trademarks not belonging to Rockwell Automation are property of their respective companies.

Rockwell Otomasyon Ticaret A.Ş., Kar Plaza İş Merkezi E Blok Kat:6 34752 İçerenköy, İstanbul, Tel: +90 (216) 5698400

www.rockwellautomation.com

Power, Control and Information Solutions Headquarters

Americas: Rockwell Automation, 1201 South Second Street, Milwaukee, WI 53204-2496 USA, Tel: (1) 414.382.2000, Fax: (1) 414.382.4444
Europe/Middle East/Africa: Rockwell Automation NV, Pegasus Park, De Kleetlaan 12a, 1831 Diegem, Belgium, Tel: (32) 2 663 0600, Fax: (32) 2 663 0640
Asia Pacific: Rockwell Automation, Level 14, Core F, Cyberport 3, 100 Cyberport Road, Hong Kong, Tel: (852) 2887 4788, Fax: (852) 2508 1846

Publication IC-TD001F-EN-P - May 2015

Supersedes Publication IC-TD001E-EN-P - September 2014

Copyright © 2015 Rockwell Automation, Inc. All rights reserved. Printed in the U.S.A.