

Signaling Specifications

Bulletin Numbers 854J, 854K, 855B, 855BS/BM/BL, 855D, 855E, 855F, 855H, 855L, 855P, 855T, 855W, 855X

Topic	Page
Summary of Changes	1
Bulletin 855P — Panel Mount Signaling Alarms	2
Bulletin 855L — Panel Light Bars	8
Bulletin 855H — General-purpose Electronic Horns	10
Bulletin 855H — High-performance Electronic Horns	12
Bulletin 855B — Mini Square Beacons	18
Bulletin 855BS, 855BM, 855BL — Industrial Round Beacons	20
Bulletin 855D — 30 mm Compact Control Tower™ Stack Lights; Pre-Assembled and Pre-wired Tower Lights, One to Five Modules	26
Bulletin 855F — 70 mm Compact Control Tower Stack Lights; Pre-Assembled and Pre-wired Tower Lights, One to Five Modules	30
Bulletin 854J — 40 mm Control Tower Stack Lights	34
Bulletin 855E — 50 mm Control Tower Stack Lights	41
Bulletin 854K — 60 mm Control Tower Stack Lights	47
Bulletin 855T — 70 mm Control Tower Stack Lights	54
Bulletin 855W — Wall Mount Signal Light	68
Bulletin 855X — Hazardous Location Horns, Beacons, and Loudspeakers	71

Summary of Changes

This publication removes information about Bulletin 854K products with the multi-flash option.

Additional Resources

These documents contain additional information concerning related products from Rockwell Automation.

Resource	Description
855 Metal Horns Selection Guide, publication 855-SG002	Provides product selection for 855XM and 855HM metal horns.
Bulletin 855 Signaling Solutions Brochure, publication 855-BR001	Provides information on the complete portfolio of signaling solutions for optimized monitoring
Industrial Automation Wiring and Grounding Guidelines, publication 1770-4.1	Provides general guidelines for installing a Rockwell Automation industrial system.
Product Certifications website, http://www.rockwellautomation.com/global/certification/overview.page	Provides declarations of conformity, certificates, and other certification details.

You can view or download publications at <http://www.rockwellautomation.com/global/literature-library/overview.page>. To order paper copies of technical documentation, contact your local Allen-Bradley distributor or Rockwell Automation sales representative.



Bulletin 855P — Panel Mount Signaling Alarms

Bulletin 855P — Panel Mount Sounder

855P – $\frac{B}{a}$ $\frac{10}{b}$ $\frac{ME}{c}$ $\frac{22}{d}$



30 mm Panel Mount Sounder



45 mm Panel Mount Sounder



65 mm Panel Mount Sounder

a	
Housing Color	
Code	Description
B	Black

b	
Voltage	
Code	Description
30	12...24V AC/DC
10	120V AC
20	240V AC

c	
Size	
Code	Description
SE	30 mm, fully enclosed, smooth front, 72 dB
SH	30 mm, high output, 80 dB
ME	45 mm
LE	65 mm

d	
Mounting Hole	
Code	Description
22	22.5 mm

Bulletin 855PC — Panel Mount Combined Sounder with LED Beacon

855PC – $\frac{B}{a}$ $\frac{10}{b}$ $\frac{ME}{c}$ $\frac{3}{d}$ $\frac{22}{e}$



45 mm Panel Mount Combined Sounder with LED Beacon



65 mm Panel Mount Combined Sounder with LED Beacon

a	
Housing Color	
Code	Description
B	Black

b	
Voltage	
Code	Description
12	12V AC/DC
24	24V AC/DC
10	240V AC
20	240V AC

c	
Size	
Code	Description
ME	45 mm
LE	65 mm

d	
Lens Color	
Code	Description
3	Green
4	Red
5	Amber
6	Blue
7	Clear
8	Yellow

e	
Mounting Hole	
Code	Description
22	22.5 mm

Bulletin 855PS — Panel Mount Strobe

855PS – $\frac{B}{a}$ $\frac{10}{b}$ $\frac{ME}{c}$ $\frac{3}{d}$ $\frac{22}{e}$



30 mm Panel Mount Strobe



45 mm Panel Mount Strobe



65 mm Panel Mount Strobe

a	
Housing Color	
Code	Description
B	Black

b	
Voltage	
Code	Description
12	12V AC/DC
24	24V AC/DC
10	240V AC
20	240V AC
30	12...24V AC/DC

c	
Size	
Code	Description
SE	30 mm ^{(1) (2)}
ME	45 mm ^{(3) (4)}
LE	65 mm ^{(3) (4)}

d	
Lens Color	
Code	Description
3	Green
4	Red
5	Amber
6	Blue
7	Clear
8	Yellow

e	
Mounting Hole	
Code	Description
22	22.5 mm

- (1) 30 mm units are LED type.
- (2) Only available in 12V AC/DC, 24V AC/DC, 120V AC, or 240V AC.
- (3) 45 and 65 mm units are Xenon strobe.
- (4) Only available in 12...24V AC/DC, 120V, or 240V AC.

Bulletin 855PB — Panel Mount Selectable Steady or Flashing LED Beacon

855PB – $\frac{B}{a}$ $\frac{10}{b}$ $\frac{ME}{c}$ $\frac{3}{d}$ $\frac{22}{e}$



30 mm Panel Mount LED Beacon



45 mm Panel Mount LED Beacon



65 mm Panel Mount LED Beacon

a	
Housing Color	
Code	Description
B	Black

b	
Voltage	
Code	Description
12	12V AC/DC
24	24V AC/DC
10	240V AC
20	240V AC

c	
Size	
Code	Description
SE	30 mm
ME	45 mm
LE	65 mm

d	
Lens Color	
Code	Description
3	Green
4	Red
5	Amber
6	Blue
7	Clear
8	Yellow

e	
Mounting Hole	
Code	Description
22	22.5 mm

Bulletin 855PD — Panel Mount Dual Circuit Alarms

855PD – $\frac{B}{a}$ $\frac{24}{b}$ $\frac{ME}{c}$ $\frac{F}{d}$ $\frac{3}{e}$ $\frac{4}{f}$ $\frac{22}{g}$



Half-Lens Illumination



Full-Lens Illumination



Combined Sounder with LED Beacon

a	
Housing Color	
Code	Description
B	Black

b	
Voltage	
Code	Description
12 ⁽¹⁾	12V AC/DC
24	24V AC/DC
10	120V AC
20	240V AC

c	
Size	
Code	Description
SE	30 mm ^{(2) (3)}
ME	45 mm
LE	65 mm

d	
Function	
Code	Description
F	2-color, full-lens illumination
H	2-color, half-lens illumination with barrier
C	Combined sounder with LED beacon ⁽³⁾

- (1) Voltage code 12 is only valid for sounder with LED devices.
- (2) 30 mm available in 24V AC/DC only, for 2-color versions.
- (3) The sounder with LED is not available in the 30 mm size.

e	
LED Color ⁽¹⁾ /Sound	
Code	Description
1	Sound
3	Green
4	Red
5	Amber
6	Blue
7	Clear
8	Yellow

f	
LED Color ⁽²⁾	
Code	Description
3	Green
4	Red
5	Amber ⁽³⁾
6	Blue
7	Clear
8	Yellow ⁽³⁾

g	
Mounting Hole	
Code	Description
22	22.5 mm

- (1) Voltage code 12 is only valid for sounder with LED devices.
- (2) For two-color devices, the first color code listed in the cat. no. corresponds to the same side as the panel tab found on the housing. For example: catalog number 855PD-B24MEH4322 indicates that the Red color is on the same side as the panel tab and the Green color is on the opposite side as the panel tab.
- (3) The color combination of Yellow and Amber is not allowed because of their similarity

Specifications

Panel Sounder and Single/Dual Circuit Panel Sounder with LED

Table 1 - Technical

Attribute		Value
Housing	Base Material	Polycarbonate, black
	Lens	Polycarbonate, red, amber, yellow, green, blue, and clear
Protection class		UL Type 4/4X/13, IP65
Terminals		Plug-in terminal block, up to 2.5 mm ² (14 AWG), IP2X
Operation temperature range		-25...+60 °C (-13...+140 °F)
Storage temperature range		-25...+85 °C (-13...+185 °F)
Mounting		Central mounting for bore holes 22 mm or 30.5 mm with hole adapter kit (Cat. No. 855P-AHA1)
Mounting nut torque		1.7 N•m (15 lb•in)

Table 2 - Electrical

Attribute		Value				
		Sounder			Sounder with Warning Light	
		65 mm	45 mm	30 mm	65 mm	45 mm
Supply voltage range	12V AC/DC - 50/60 Hz	—	—	—	±10%	±10%
	24V AC/DC - 50/60 Hz	—	—	—	±10%	±10%
	12...24V AC/DC - 50/60 Hz	8...26V AC/DC	8...26V AC/DC	10...26V AC/DC	—	—
	120V AC - 50/60 Hz	50...140V AC	50...140V AC	80...140V AC	±10%	±10%
	230/240V AC - 50/60 Hz	150...260V AC	150...260V AC	180...260V AC	±10%	±10%
Nominal current — single circuit (dual circuit)	12V AC/DC - 50/60 Hz	—	—	—	50 mA (62 mA)	35 mA (48 mA)
	24V AC/DC - 50/60 Hz	57 mA	20 mA	20 mA	73 mA (95 mA)	58 mA (73 mA)
	120V AC - 50/60 Hz	40 mA	40 mA	20 mA	60 mA (52 mA)	40 mA (51 mA)
	230/240V AC - 50/60 Hz	42 mA	42 mA	20 mA	63 mA (52 mA)	42 mA (51 mA)
Turn-on leakage current		≥3 mA	≥3 mA	≥3 mA	≥3 mA	≥3 mA
Sound level, max (average)		105 dB(A) @ 1 m	100 dB(A) @ 1 m	SE: 72 dB(A) @ 1 m SH: 80 dB(A) @ 1 m	103 dB(A) @ 1 m	98 dB(A) @ 1 m
Sound level, min		< 85 dB	< 85 dB	—	< 85 dB	< 85 dB
Sound level adjustment		Stepless	Stepless	—	Stepless	Stepless
Sound main frequency		3300 Hz	3300 Hz	3500 Hz	3300 Hz	3300 Hz
Sound types	Continuous	Yes	Yes	Yes	Yes	Yes
	Pulsing ⁽¹⁾	Yes	Yes	Yes	Yes	Yes
	Alternating frequency ⁽¹⁾	Yes	No	No	Yes	No
Sound selection		Externally by terminal connection				
Weight		65 g (2.3 oz)	35 g (1.2 oz)	25 g (0.9 oz)	85 g (3 oz)	55 g (1.9 oz)

(1) Single Circuit only.

Standards Compliance

- EN/IEC 60947-1
- EN/IEC 60947-5-1
- UL 508
- CSA C22.2 No. 14

Certifications

- cULus Listed (File No. E14840, Guides NKCR, NKCR7)
- CE Marked

Panel Strobe and Single/Two Color LED Lights

Table 3 - Technical

Attribute		Value
Housing	Base Material	Polycarbonate, black
	Lens	Polycarbonate, red, amber, yellow, green, blue, and clear
Protection class		UL Type 4/4X/13, IP2X, IP65
Terminals		Plug-in terminal block, up to 2.5 mm ² (14 AWG), IP2X fingersafe
Operation temperature range		-25...+60 °C (-13...+140 °F)
Storage temperature range		-25...+85 °C (-13...+185 °F)
Mounting		Central mounting for bore holes 22 mm or 30.5 mm with hole adapter kit (Cat. No. 855P-AHA1)
Mounting nut torque		1.7 N·m (15 lb·in)

Table 4 - Electrical

Attribute		Value					
		LED Beacon — Steady/Flashing			Strobe Light		
		65 mm	45 mm	30 mm	65 mm	45 mm	30 mm
Supply voltage range	12V AC/DC, 50/60 Hz	±10%	±10%	±10%	—	—	±10%
	24V AC/DC, 50/60 Hz	±10%	±10%	±10%	—	—	±10%
	12...24V AC/DC, 50/60 Hz	—	—	—	8...26V AC/DC	8...26V AC/DC	—
	120V AC, 50/60 Hz	±10%	±10%	±10%	±10%	±10%	±10%
	230/240V AC, 50/60 Hz	±10%	±10%	±10%	±10%	±10%	±10%
Nominal current — single circuit (dual circuit)	12V AC/DC, 50/60 Hz	75 mA	60 mA	30 mA	—	—	15 mA
	24V AC/DC, 50/60 Hz	54 mA (full: 71 mA half: 44 mA)	35 mA (full: 46 mA half: 39 mA)	25 mA (full: 28 mA half: 30 mA)	—	—	10 mA
	12...24V AC/DC, 50/60 Hz @ 12V	—	—	—	150 mA	110 mA	—
	12...24V AC/DC, 50/60 Hz @ 24V	—	—	—	140 mA	100 mA	—
	120V AC, 50/60 Hz	25 mA (full: 61 mA half: 41 mA)	25 mA (full: 35 mA half: 35 mA)	20 mA	30 mA	20 mA	10 mA
	230/240V AC, 50/60 Hz	25 mA (full: 61 mA half: 41 mA)	25 mA (full: 35 mA half: 34 mA)	20 mA	20 mA	12 mA	10 mA
Turn-on leakage current		≥3 mA	≥3 mA	≥3 mA	≥3 mA	≥3 mA	≥3 mA
Steady/Flashing light		Externally by terminal connection			—	—	—
Flashing frequency		2 Hz	2 Hz	2 Hz	min. 1.4 Hz	min. 1.4 Hz	min. 1.4 Hz
Light source		LED			Xenon tube		LED
Flash energy		—	—	—	1 J	1.5 J	—
Weight		60 g (2.1 oz)	40 g (1.4 oz)	40 g (1.4 oz)	80 g (2.8 oz)	60 g (2.1 oz)	40 g (1.4 oz)

Approximate Dimensions

Dimensions in millimeters (inches). Dimensions are not intended to be used for manufacturing purposes.

Terminal connector for 30 mm devices adds 14 mm (0.55 in.) to back-of-panel depth

Terminal connector for 45 mm and 65 mm devices adds 9 mm (0.35 in.) to back-of-panel depth

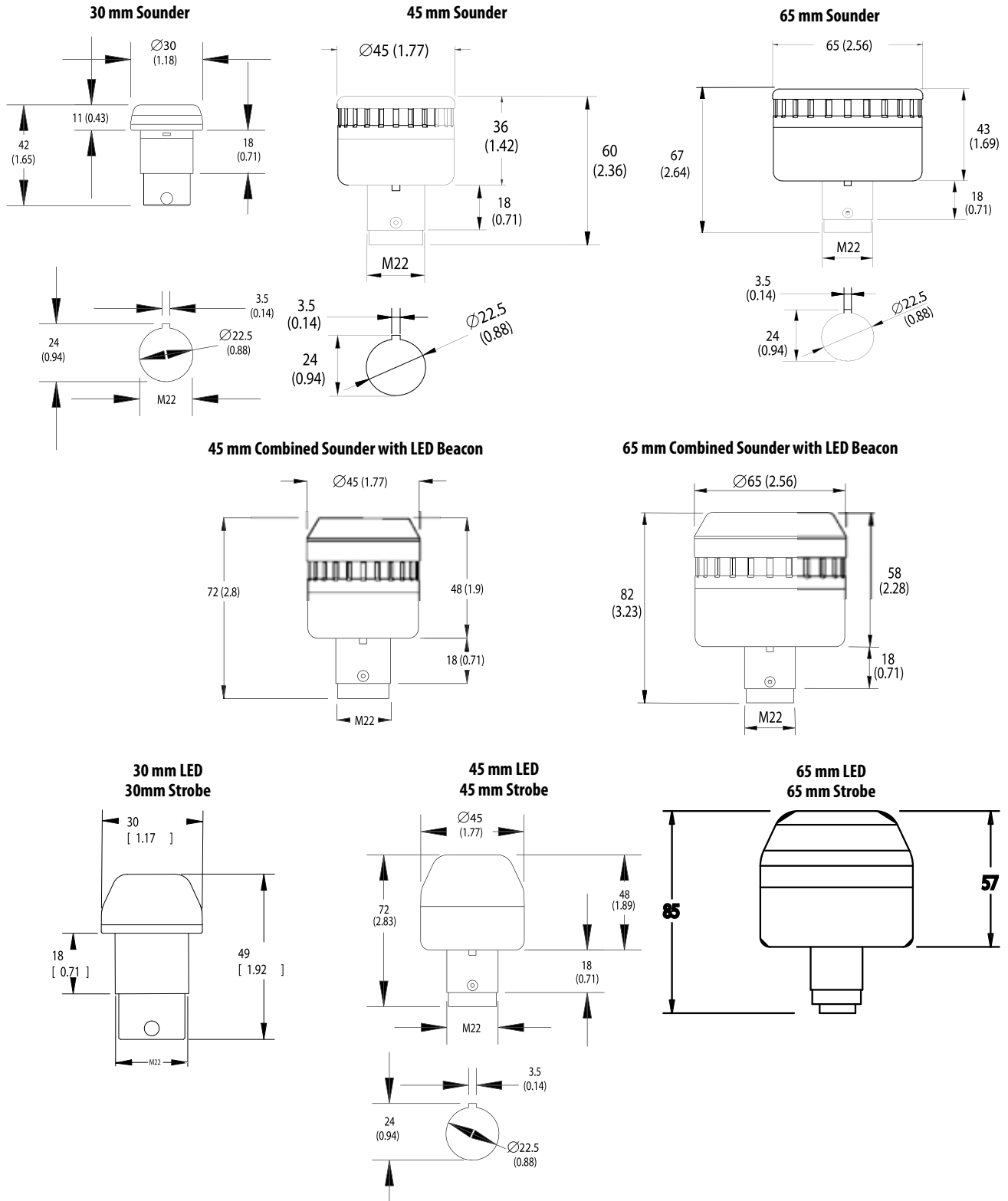

Bulletin 855L — Panel Light Bars

Specifications



Attribute	855L-NX1 (24...48V with ON/OFF switch) 855L-NX2 (24...48V - no switch)	855L-NX3 (110...240V with ON/OFF switch) 855L-NX4 (110...240V - no switch)
Nominal Input Voltage	24...48V AC/DC, 50/60 Hz	855L-NX3: 110...240V AC, 50/60 Hz 855L-NX4: 110...240V AC/DC, 50/60 Hz
Input Voltage Limits	17...63V DC 17...53V AC, 50/60 Hz	90...320V DC (855L-NX4 only) 90...250V AC, 50/60 Hz
Nominal Current	~300 mA @ 24V DC / ~150 mA @ 48V DC	<70 mA @ 120V AC / <55 mA @ 240V AC
Inrush Current	1 A @ 24V DC, ~2 A @ 48V DC, +25 °C	~3.5 A @ 120V AC / ~7 A @ 240V AC
Leakage Current Immunity	>8 mA DC	>3 mA AC / ~1 mA DC
Ingress Protection	855L-NX1: NEMA 1, IP40 855L-NX2: NEMA 1, IP44	855L-NX3: NEMA 1, IP40 855L-NX4: NEMA 1, IP44
Operating Temperature Range	-31...+140 °F (-35...+60 °C)	
Storage Temperature Range	-31...+185 °F (-35...+85 °C)	
Wire Size	22...14 AWG (0.5...2.5 mm ²)	
Light Beam Angle	~70°	
LED Color	White	
Light Output	470 lumens, minimum	
Lens Material	Polycarbonate (clear)	
Base Material	Polycarbonate (light gray)	
Mounting Orientation	No restrictions	
Mounting Screws (not provided)	2 X 1/4 in. (M5/ M6)	
Weight	<1 lb (380 g)	
Standards Compliance	EN61000-6-2, EN61000-6-3, EN60947-5-1	
Certifications	CE Marked, cULus File No. E14840	
LED MTFB	50,000 hr	

Approximate Dimensions

Dimensions in millimeters (inches). Dimensions are not intended to be used for manufacturing purposes.

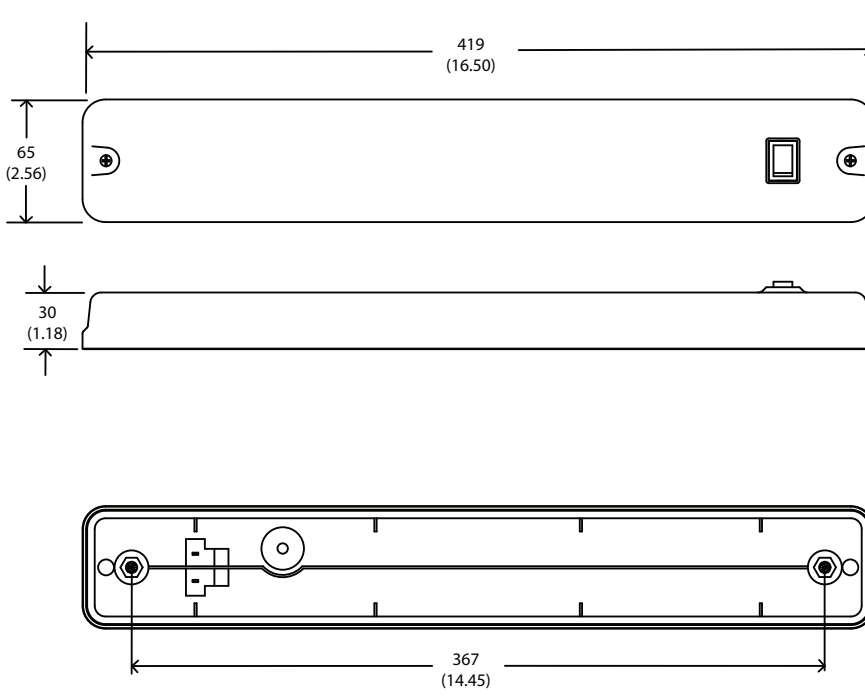

Bulletin 855H — General-purpose Electronic Horns

Single- or dual-circuit, selectable tone horns, with volume control, for use in general signaling applications.



855H – $\frac{SG}{a}$ $\frac{10}{b}$ $\frac{GPA}{c}$

a	
Mounting Type	
Code	Description
FG	Semi-flush wall plate, gray housing
SG	Surface base with two conduit entrances, gray housing

b	
Voltage	
Code	Description
24	24V AC/DC
10	120V AC
20	240V AC
30	10...30V DC
45	40...260V AC/DC, 50/60 Hz

c	
Horn Type	
Code	Description
GPA ⁽¹⁾	General-purpose, 108 dB(A) max, single stage/circuit, three tones
GPE ⁽²⁾	Enhanced version, 113 dB(A) max @ 1 m, two stage, three tones, volume control

(1) Not valid with voltage codes 30 and 45 (Table b).

(2) Not valid with mounting type FG (Table a) or with voltage codes 24, 10, and 20 (Table b).

Specifications

Table 5 - Environmental

Attribute		Value
Ingress Ratings	Semi-flush Mount	UL Type 3R/13, IP54
	Surface Mount	UL Type 4/4X/13/3R, IP66
Temperature Ranges	Operating	-25...+55 °C (-13...+131 °F)
	Storage	-40...+70 °C (-40...+158 °F)

Table 6 - Materials

Attribute	Value
Housings including horn cover and base	Polycarbonate
O-ring	NBR
Gasket (mounting type FG)	EPDM/SBR closed cell foam

Table 7 - Performance Ratings

Attribute	Value
Sound Output	105±3 dB(A) @ 1 m (standard), 110±3 dB(A) @ 1 m (enhanced)

Table 8 - Operating Voltage and Currents

Attribute		Value			
		DC Voltage	AC Voltage		
Input Voltage Ranges	Standard (GPA)	24V DC (±25%)	24V AC 50/60 Hz (±10%)	120V AC 50/60 Hz (±10%)	240V AC 50/60 Hz (±10%)
	Enhanced (GPE)	10...30V DC	40...260V AC/DC		
Input Currents @ Nominal Voltage	Standard (GPA)	62 mA	220 mA	40 mA	50 mA
	Enhanced (GPE)	105 mA	—	36 mA	18 mA

Standards Compliance

- UL 464
- CSA C22.2 No. 205
- EN/IEC 60947-1
- EN/IEC 60947-5-1
- EN 6100-6-2
- EN 6100-6-3

Certifications

- cULus Listed (File No. S6583, Guides UCST, UCST7)
- CE Marked

Approximate Dimensions

Dimensions in millimeters (inches). Dimensions are not intended to be used for manufacturing purposes.

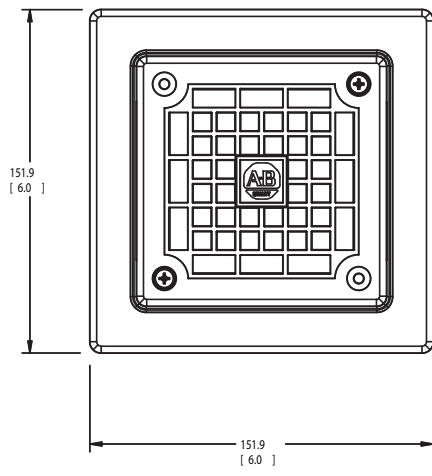

Semi-flush Mount

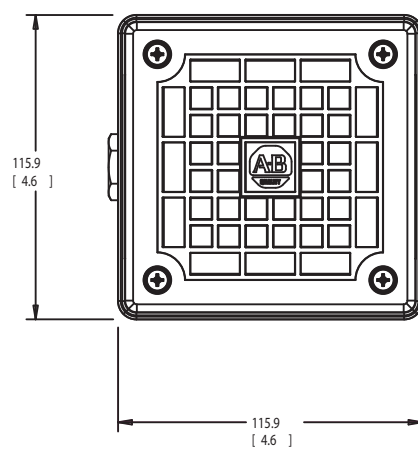
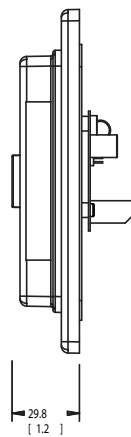

Surface Mount

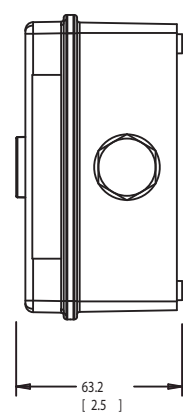

Bulletin 855H — High-performance Electronic Horns

High-performance Electronic Horns

855H – $\frac{B}{a}$ $\frac{D30}{b}$ $\frac{B}{c}$ $\frac{D}{d}$



Range "A" Industrial Horn



Range "C" Industrial Horn



Range "E" Industrial Horn

a	
Product Type	
Code	Description
B	Industrial horn, gray housing

b	
Voltage	
Code	Description
D30	10...30V DC
A24	24V AC, 50/60 Hz
A10	115V AC, 50/60 Hz
A20	230V AC, 50/60 Hz

c	
Horn Type	
Code	Description
A	100 dB, 10 tone, 2-stage (DC)
	100 dB, 10 tone, 1-stage (AC)
B	104 dB, 32 tone, 3-stage (DC)
	104 dB, 32 tone, 3-stage (AC)
C	112 dB, 32 tone, 3-stage (DC)
	112 dB, 32 tone, 3-stage (AC)
D	119 dB, 45 tone, 3-stage (DC)
	119 dB, 45 tone, 3-stage (AC)
E	126 dB, 45 tone, 3-stage (DC)
	126 dB, 45 tone, 3-stage (AC)

d	
Mount Option	
Code	Description
D	Standard base for surface or on-the-wall mounting with conduit openings and hole plugs

High-performance Electronic Horns with Attached Strobe Beacons

855H – $\frac{BC}{a}$ $\frac{D12}{b}$ $\frac{E}{c}$ $\frac{D}{d}$ $\frac{R}{e}$ $\frac{3}{f}$



Range "A" Horn with Beacon



Range "C" Horn with Beacon



Range "E" Horn with Beacon

a	
Product Type	
Code	Description
BC	Electronic horn with Xenon strobe beacon, gray housing

b	
Voltage	
Code	Description
D12	12V DC
D24	24V DC
A24	24V AC, 50/60 Hz
A10	115V AC, 50/60 Hz
A20	230V AC, 50/60 Hz

c	
Horn Type	
Code	Description
A	100 dB, 10 tone, 2-stage (DC)
	100 dB, 10 tone, 1-stage (AC)
B	104 dB, 32 tone, 3-stage (DC)
	104 dB, 32 tone, 3-stage (AC)
C	112 dB, 32 tone, 3-stage (DC)
	112 dB, 32 tone, 3-stage (AC)
D	119 dB, 45 tone, 3-stage (DC)
	119 dB, 45 tone, 3-stage (AC)
E	126 dB, 45 tone, 3-stage (DC)
	126 dB, 45 tone, 3-stage (AC)

d	
Mount Option	
Code	Description
D	Standard base for surface or on-the-wall mounting with conduit openings and hole plugs

e	
Illuminated Function	
Code	Description
R	5 J strobe

f	
Lens Color	
Code	Description
3	Green
4	Red
5	Amber
6	Blue
7	Clear
8	Yellow

Specifications

Table 9 - Mechanical

Attribute	Value	
Shock and Vibration	Listed below are reference guidelines for maximum shock and vibration standards for the 855H.	
	Shock	Vibration
Range A Horn	15 G Peak	3 G Peak
Range B Horn	15 G Peak	3 G Peak
Range C Horn	15 G Peak	3 G Peak
Range D Horn	15 G Peak	3 G Peak
Range E Horn	15 G Peak	1 G Peak
Range A Horn with Strobe Beacon	15 G Peak	3 G Peak
Range B Horn with Strobe Beacon	15 G Peak	3 G Peak
Range C Horn with Strobe Beacon	15 G Peak	3 G Peak
Range D Horn with Strobe Beacon	15 G Peak	3 G Peak
Range E Horn with Strobe Beacon	15 G Peak	1 G Peak

Table 10 - Environmental

Attribute	Value	
Ingress Ratings	Electronic Horns	UL Type 13/3R, IP56
	Horn with Beacon	UL Type 13, IP56
Temperature Ranges	Operating	-13...+131 °F (-25...+55 °C)
	Storage	-40...+167 °F (-40...+75 °C)

Table 11 - Materials

Attribute	Value
Horn Cover and Base	ABS
Beacon Housing	Polycarbonate
Beacon Lens	Polycarbonate
Gasket (Cover to Base)	Nitrile 70
Gasket (Enclosure back to wall)	Nitrile 70
Gasket (Horn to Beacon)	Nitrile 70
Gasket (Screw Mounting Hole)	Fiber

Table 12 - Performance Ratings

Attribute	Value	
Sound Output	Range A Horn	100 dB max @ 1 m
	Range B Horn	104 dB max @ 1 m
	Range C Horn	112 dB max @ 1 m
	Range D Horn	119 dB max @ 1 m
	Range E Horn	126 dB max @ 1 m
Xenon Lamp Rating	Strobe Beacon	5 J output

Table 13 - Operating Voltage

Attribute	Value				
	DC Voltage		AC Voltage		
	Range A	Range B	Range C	Range D	Range E
All Horns	10...30V DC	10...30V DC	24V AC, 50/60 Hz (±10%)	115V AC, 50/60 Hz (±10%)	230V AC, 50/60 Hz (±10%)
All Horns with Strobe Beacon	12V DC ±10%	24V DC ±10%			

Table 14 - Current Consumption [mA]

Attribute		Value				
		Range A	Range B	Range C	Range D	Range E
Horns	10...30V DC	25	25	25	200	950
	24V AC, 50/60 Hz	40	40	40	500	1000
	115V AC, 50/60 Hz	13	20	20	100	240
	240V AC, 50/60 Hz	13	15	15	60	120
Horns with Strobe Beacon	12V DC	525	525	525	700	1450
	24V DC	275	275	275	450	1200
	24V AC	405	405	405	865	1200
	115V AC	113	120	120	200	340
	240V AC	63	65	65	110	170

Table 15 - Flashing Frequency

Attribute		Value				
		Range A	Range B	Range C	Range D	Range E
Strobe Beacon		1 Hz				

Standards Compliance

- UL 464
- CSA C22.2 No. 205
- EN/IEC 60947-1
- EN/IEC 60947-5-1
- EN 6100-6-2
- EN 6100-6-4

Certifications

- cULus Listed (File No. S6583, Guides UCST, UCST7)
- CE Marked

Approximate Dimensions

Dimensions in millimeters (inches). Dimensions are not intended to be used for manufacturing purposes.

Horns

Range A and B

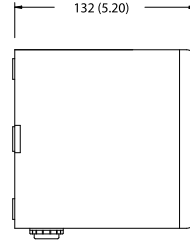
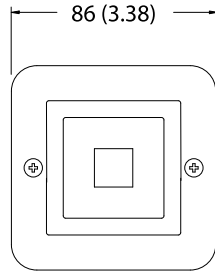
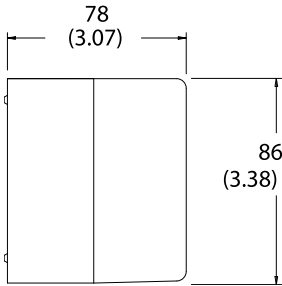

Range C

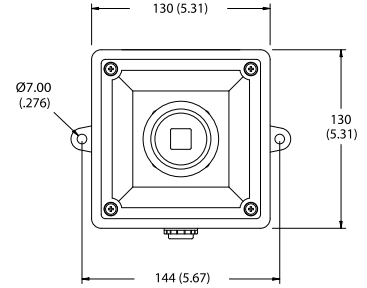

Range D

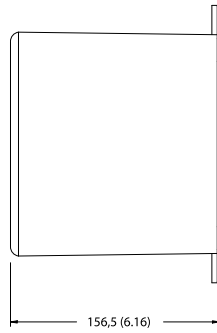
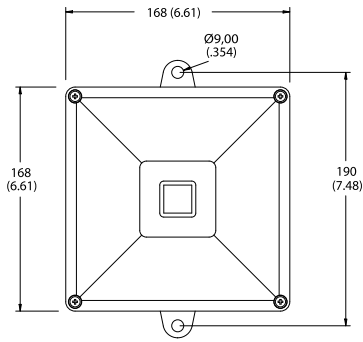

Range E

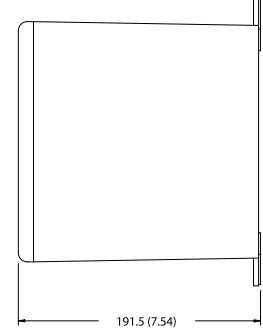
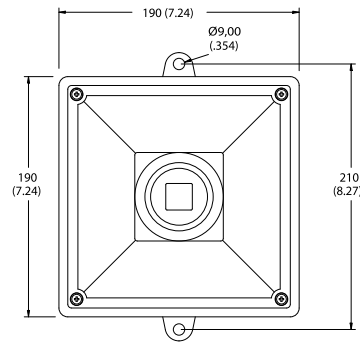

Dimensions in millimeters (inches). Dimensions are not intended to be used for manufacturing purposes.

Horns with Beacons

Range A and B

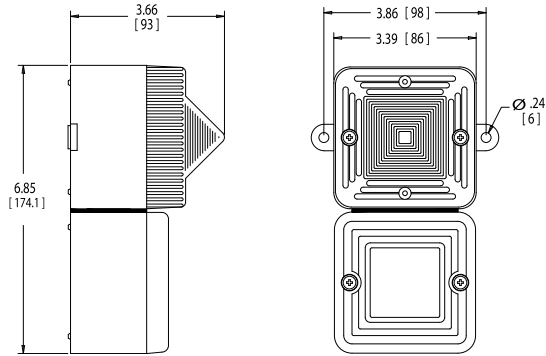

Range C

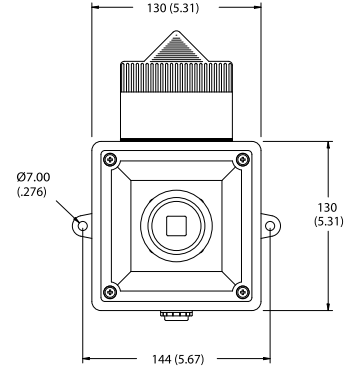

Range D

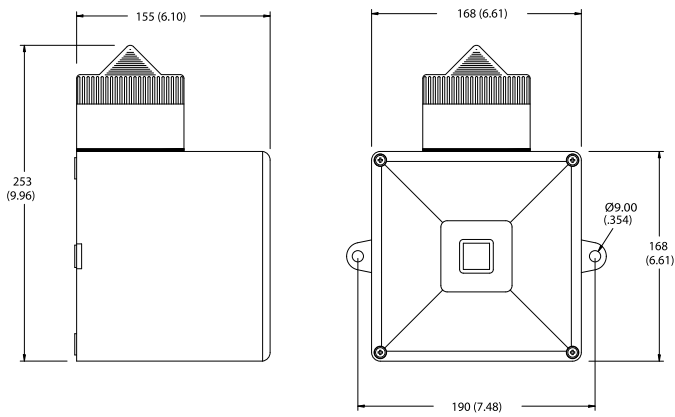

Range E

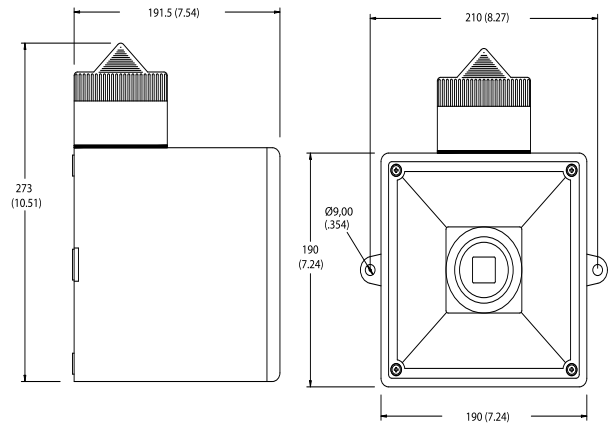

Bulletin 855B — Mini Square Beacons

855B - $\frac{G}{a}$ $\frac{MS}{b}$ $\frac{12}{c}$ $\frac{R}{d}$ $\frac{3}{e}$



Mini Square Strobe Beacon

a	
Housing Color	
Code	Description
G	Gray

b	
Beacon Type	
Code	Description
MS	Mini square beacon

c	
Voltage	
Code	Description
24	24V AC/DC
10	115V AC, 50/60 Hz
20	230V AC, 50/60 Hz

d	
Illumination Type	
Code	Description
R	5 J Strobe

e	
Lens Color	
Code	Description
3	Green
4	Red
5	Amber
6	Blue
7	Clear
8	Yellow

Specifications

Table 16 - Mechanical

Attribute	Value	
Shock and Vibration	Listed below are reference guidelines for maximum shock and vibration standards for the 855B beacon lights.	
	Shock	Vibration
	All strobe beacons	50 G Peak

Table 17 - Environmental

Attribute	Value
Ingress Ratings	UL Type 13/3R, IP66
Operating Temperature Ranges	-12...+131 °F (-25...+55 °C)

Table 18 - Materials

Attribute	Value
Housing and Lens	Polycarbonate
Gasket	Nitrile 70

Table 19 - Performance Ratings

Attribute	Value
Xenon Lamp Rating	All Strobe Beacons
	5 J

Table 20 - Operating Voltage

Attribute	Value		
All Strobe Beacon	24V AC/DC, 50/60 Hz (±20%)	120V AC, 50/60 Hz (±10%)	230V AC, 50/60 Hz (±10%)

Table 21 - Current Consumption [mA]

Attribute		Value
All Strobe Beacons	24V AC/DC	365/250
	120V AC	100
	230V AC	50

Table 22 - Flashing Frequency

Attribute	Value
Strobe Beacon	1 Hz

Standards Compliance

- UL 464
- UL 1638
- CSA C22.2 No. 205
- EN/IEC 60947-1
- EN/IEC 60947-5-1
- EN 6100-6-2
- EN 6100-6-4
- CAN/ULLC-S526-M87

Certifications

- cULus Listed (File No. E197159, Guides UUES, UEES7)
- CE Marked

Approximate Dimensions

Dimensions in millimeters (inches). Dimensions are not intended to be used for manufacturing purposes.

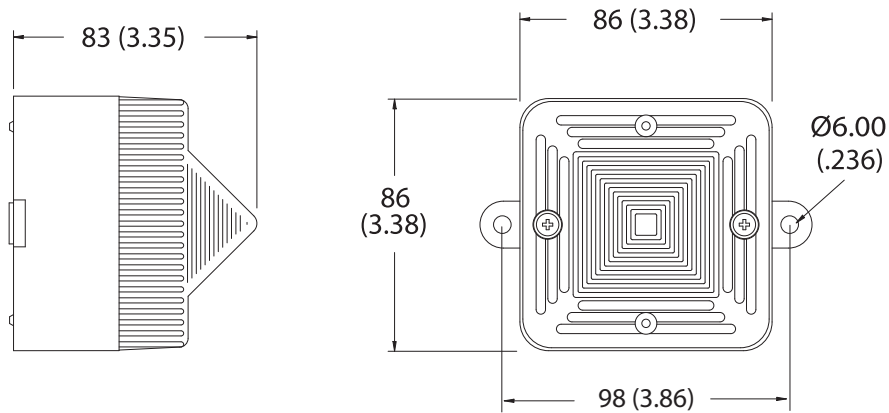

Bulletin 855BS, 855BM, 855BL — Industrial Round Beacons



Bulletin 855BS — 90 mm Beacons

855BS – $\frac{S}{a}$ $\frac{10}{b}$ $\frac{RH}{c}$ $\frac{3}{d}$

a	
Base Type	
Code	Description
S	Surface mount ⁽¹⁾
N	1/2 in. NPT conduit mount
T	25 mm tube mount ⁽²⁾

b	
Voltage	
Code	Description
12	12V AC/DC
24	24V AC/DC
10	120V AC
20	240V AC
35	24/48V AC/DC
45	120/240V AC/DC

c	
Function	
Code	Description
DH	Steady halogen
FH	Flashing halogen
RH	Rotating halogen
BR	Xenon tube strobe ⁽³⁾
SL	LED single color selectable steady/flash ⁽⁴⁾
ML	LED three color ^{(5) (6)}
BL	LED strobe selectable single/double flash ⁽⁷⁾

d	
Lens Color	
Code	Description
345	Green, red, amber ⁽⁶⁾
3	Green
4	Red
5	Amber
6	Blue
7	Clear
8	Yellow

- (1) Surface mount base must be installed with rough wall plate for UL Type 4/4X/13 rating, otherwise UL Type 1 only.
- (2) 25 mm tube mount is UL Recognized, other mounting types are UL Listed.
- (3) Not available in 12V AC/DC.
- (4) SL function uses 35 (16...60V AC/16...80V DC) and 45 (90...250V AC/DC) voltage codes only
- (5) ML function uses 24, 10, and 20 voltage codes only.
- (6) Green, Red, Amber color combination is only valid for the three color LED selection (ML).
- (7) BL function uses 35 (19...52V AC/16...60V DC), 10, and 20 voltage codes only.

Bulletin 855BM — 120 mm Beacons

855BM – $\frac{S}{a}$ $\frac{10}{b}$ $\frac{FH}{c}$ $\frac{4}{d}$

a	
Base Type	
Code	Description
S	Surface mount ⁽¹⁾
N	1/2 in. NPT conduit mount
T	25 mm tube mount

b	
Voltage	
Code	Description
12	12V AC/DC
24	24V AC/DC
10	120V AC
20	240V AC

c	
Function	
Code	Description
DH	Steady halogen
FH	Flashing halogen
RH	Rotating halogen
BR	Xenon tube strobe ⁽²⁾

d	
Lens Color	
Code	Description
3	Green
4	Red
5	Amber
6	Blue
7	Clear
8	Yellow

- (1) When used outdoors surface mount base must be installed with rough wall plate for UL Type 4/4X/13 rating, otherwise UL Type 1 only.
- (2) Not available in 12V AC/DC.

Bulletin 855BL — 160 mm Beacons

855BL - $\frac{N}{a}$ $\frac{24}{b}$ $\frac{DH}{c}$ $\frac{5}{d}$

a	
Base Type	
Code	Description
S	Surface mount ⁽¹⁾
N	1/2 in. NPT conduit mount
T	25 mm tube mount

b	
Voltage	
Code	Description
12	12V AC/DC
24	24V AC/DC
10	120V AC
20	240V AC

c	
Function	
Code	Description
DH	Steady halogen
FH	Flashing halogen
RH	Rotating halogen
BR	Xenon tube strobe ⁽²⁾

d	
Lens Color	
Code	Description
3	Green
4	Red
5	Amber
6	Blue
7	Clear
8	Yellow

- (1) When used outdoors surface mount base must be installed with rough wall plate for UL Type 4/4X/13 rating, otherwise UL Type 1 only.
 (2) Not available in 12V AC/DC.

Specifications

Table 23 - Technical

Attribute		Value
Housing	Base material	Polycarbonate
	Lenses (all)	Polycarbonate, red, amber, yellow, green, blue, and clear
	Pole mount base	90 mm: polycarbonate 120 mm and 160 mm: aluminum die cast, powder-coated
	Bracket	Powder-coated steel
Protection class		Type 4/4X/13 (surface mount base must be installed with rough wall plate for Type 4/4X/13 rating), IP65
Terminals (120 mm and 160 mm only)		Up to 2.5 mm ² (14 AWG)
Temperature Ranges	Operating	-25...+60 °C (-13...+140 °F); -25...+50 °C (-13...+122 °F), 120 & 160 mm steady halogen, and 120/240V AC single-color LED
	Storage	-25...+85 °C (-13...+185 °F)
Mounting	Horizontal surfaces:	Indoor — direct to the surface, outdoor — with additional metal plate between surface and base part
	Vertical surfaces	With bracket, for indoor and outdoor
	Tube or NPT conduit	For indoor and outdoor

Table 24 - Electrical and Mechanical

Attribute		Value											
		Steady Halogen			Flashing Halogen			Strobe			Rotating Light		
		160 mm	120 mm	90 mm	160 mm	120 mm	90 mm	160 mm	120 mm	90 mm	160 mm	120 mm	90 mm
Halogen bulb	[W]	50	35	20	50	35	20	—	—	—	50	35	20
Bulb socket		GY6.35	GY6.35	GY6.35	GY6.35	GY6.35	GY6.35	—	—	—	GY6.35	GY6.35	GY6.35
Strobe energy	[J]	—	—	—	—	—	—	31	15	7	—	—	—
Xenon strobe tube		—	—	—				Helical	Helical	Helical	—	—	—
Strobe tube socket		—	—	—				Terminals	Terminals	Terminals	—	—	—
Flashing/Strobe frequency	[Hz]	—	—	—	1	1	1	1	1	1	—	—	—
Rotating speed - selectable via jumper wire	[rpm]	—	—	—	—	—	—	—	—	—	90/180	90/180	90/180
Nominal Current [mA]	12V AC/DC	4	2.9	1.6	4.2	3	1.6	—	—	—	4.2	3.2	1.8
	24V AC/DC	2.1	1.5	0.8	2.1	1.5	0.8	1.9	1.3	0.48	2.3	1.7	0.95
	110/120V AC, 50/60 Hz	0.42	0.329	0.2	0.42	0.3	0.2	0.7	0.32	0.21	0.58	0.32	0.30
	230/240V AC, 50 Hz	0.21	0.15	0.09	0.21	0.15	0.09	0.35	0.15	0.12	0.39	0.17	0.27
Weight [g]	Surface Mount	900	500	251	900	500	251	900	500	296	900	500	378
	Tube Mount	900	500	424	900	500	424	900	500	469	900	500	551

Attribute		Value		
		90 mm		
		Single-color LED	Three-color LED	Strobe LED
Nominal Current [mA]	24V AC/DC	—		155
	110/120V AC, 50/60 Hz	—		70
	230/240V AC, 50 Hz	—		70
	24/48V AC/DC, 50/60 Hz	230...270 (16...60V AC/ 16...80V DC)		300 (19...52V AC/ 16...60V DC)
	120/240V AC	38...43 mA (90...250V AC)		—
Weight [g]	Surface Mount	250		
	Tube Mount	450		

Standards Compliance

- UL 508
- EN/IEC 60947-1
- EN/IEC 60947-5-1
- CSA C22.2 No. 14

Certifications

- cULus Listed (File No. E14840, Guides NKCR, NKCR7)
- CE Marked

Approximate Dimensions

Dimensions in millimeters (inches). Dimensions are not intended to be used for manufacturing purposes.

90 mm Beacon, NPT Conduit Mount

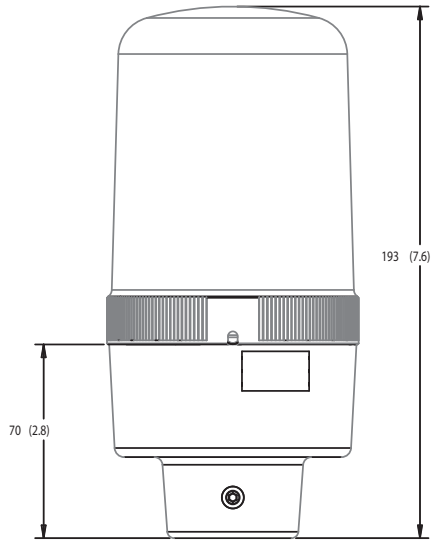

90 mm Beacon, Surface Mount

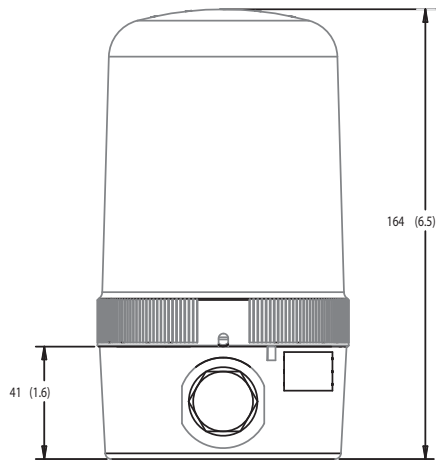

90 mm Beacon, Tube Mount

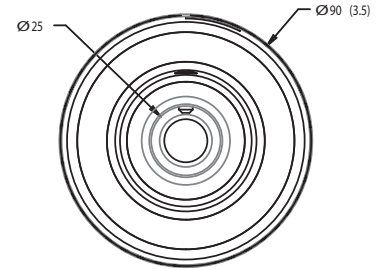
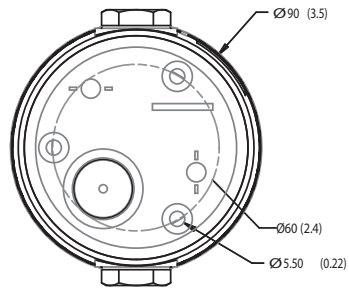
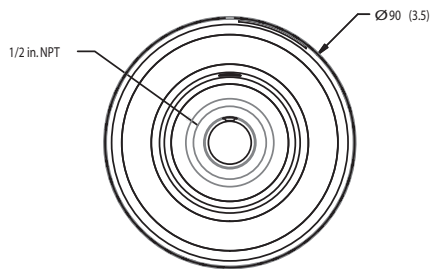
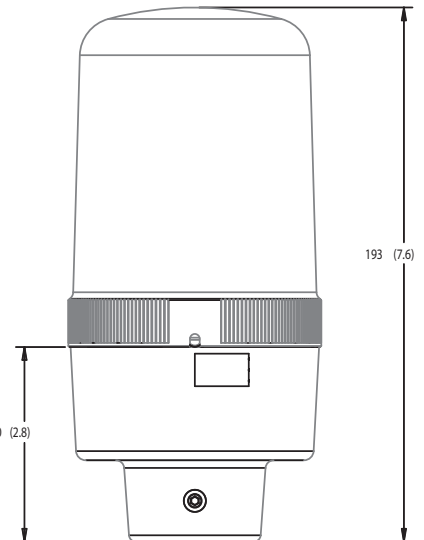

90 mm Beacon, Vertical Bracket

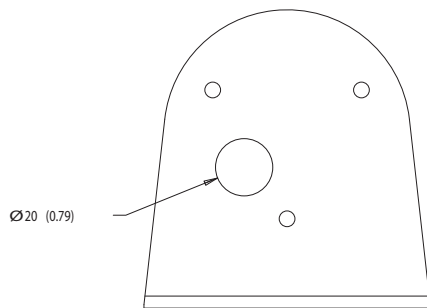

90 mm LED Beacon

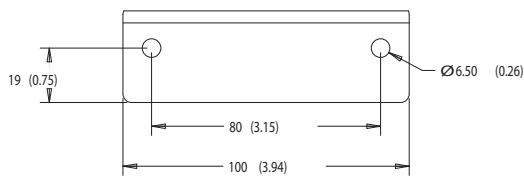
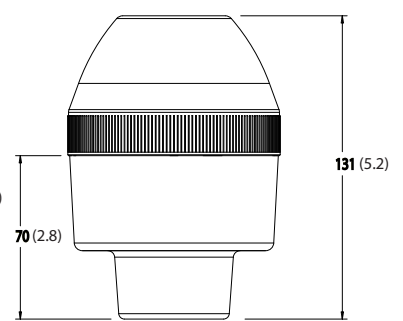
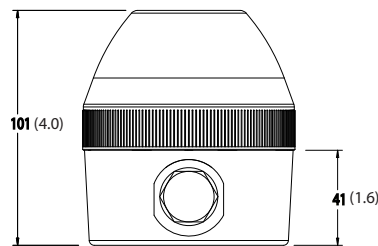

Dimensions in millimeters (inches). Dimensions are not intended to be used for manufacturing purposes.

120 mm Beacon, NPT Conduit Mount

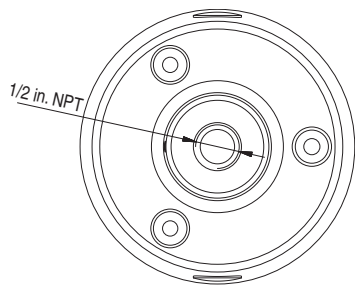
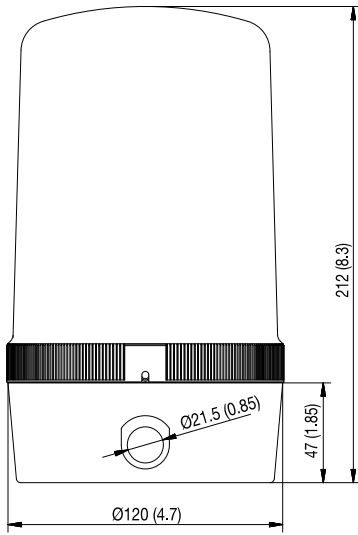

120 mm Beacon, Surface Mount

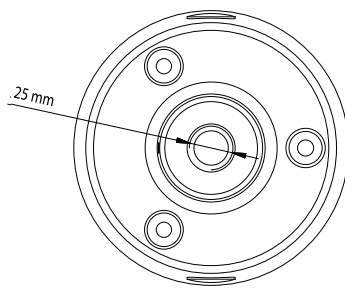
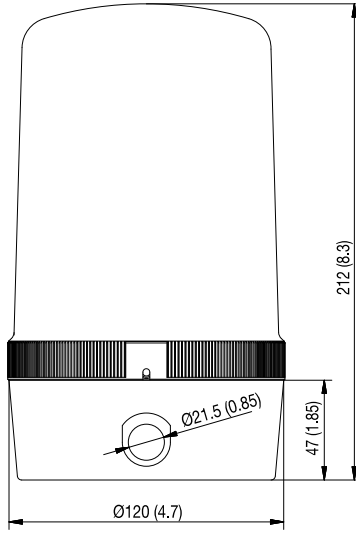

120 mm Beacon, Tube Mount

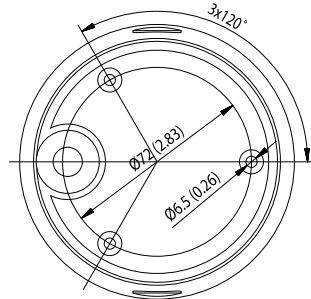
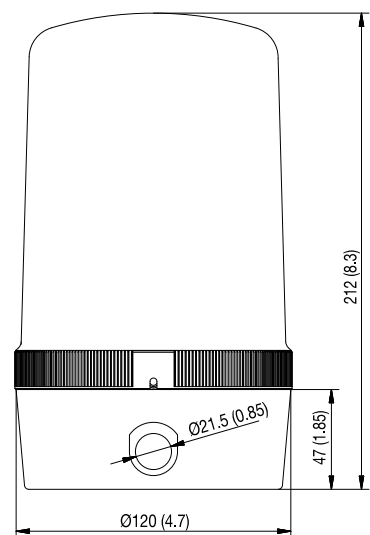

120 mm Beacon, Vertical Bracket

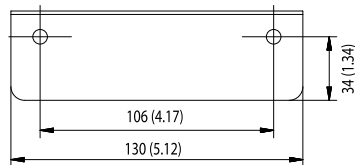
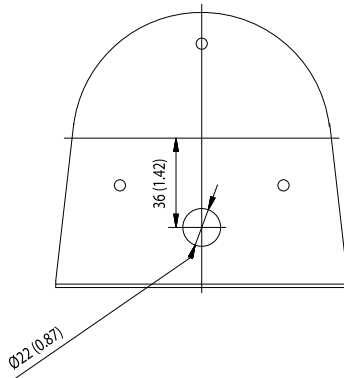

Dimensions in millimeters (inches). Dimensions are not intended to be used for manufacturing purposes.

160 mm Beacon, NPT Conduit Mount

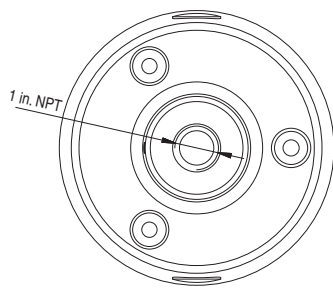
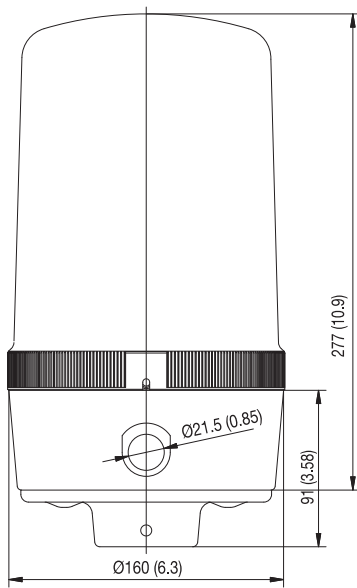

160 mm Beacon, Surface Mount

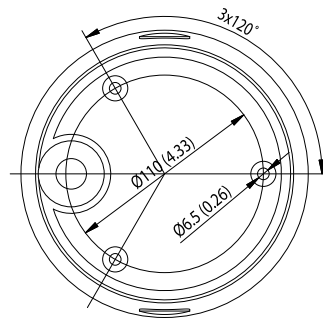
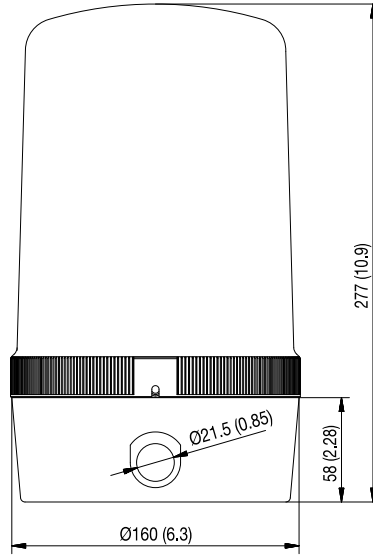

160 mm Beacon, Tube Mount

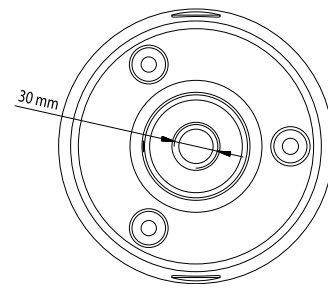
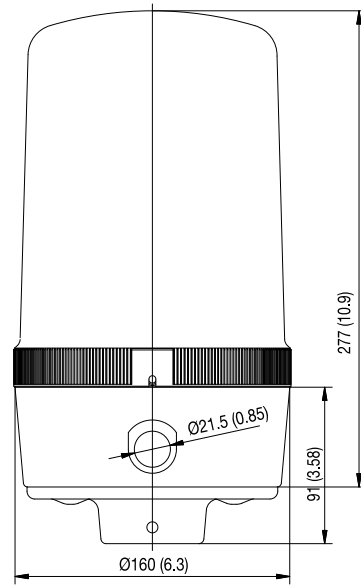

160 mm Beacon, Vertical Bracket

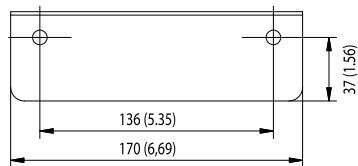
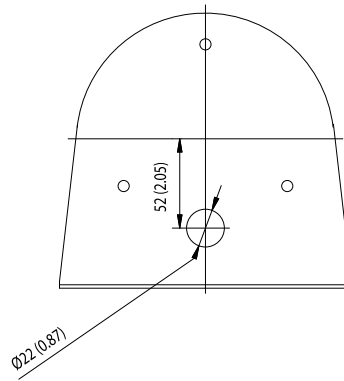

Bulletin 855D — 30 mm Compact Control Tower™ Stack Lights; Pre-Assembled and Pre-wired Tower Lights, One to Five Modules

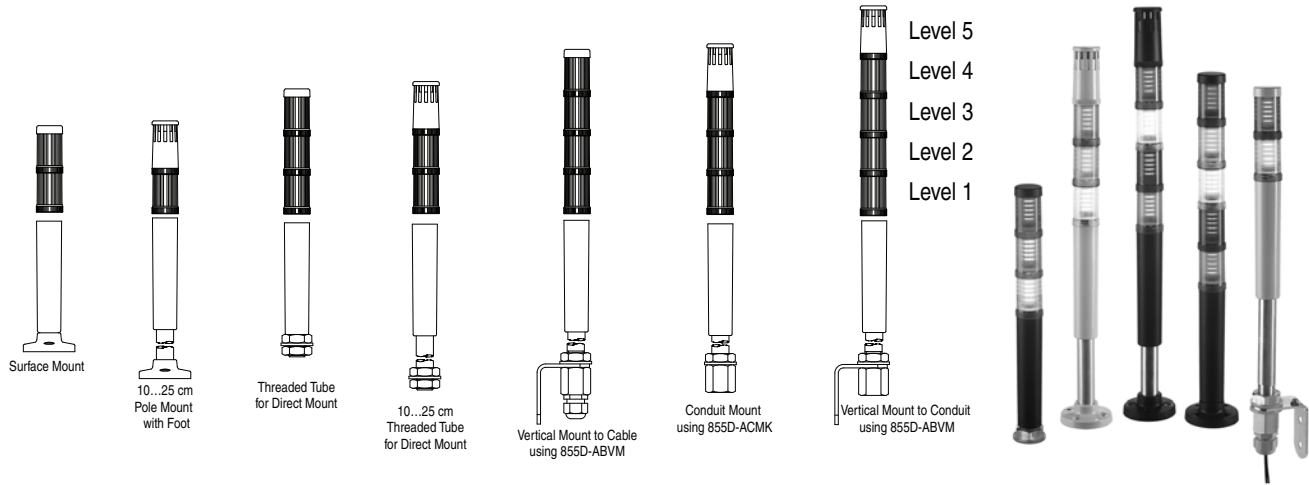

855D – P00 SC20 B 24 Y 3 Y 4 Y 5 L 7 P 1
 a b c d e f g f g f g f g f g
 (Level 1, f+g) (Level 2, f+g) (Level 3, f+g) (Level 4, f+g) (Level 5, f+g)

a	
Base Type	
Code	Description
P00	Surface mount
P10	10 cm aluminum pole mount with foot
P25	25 cm aluminum pole mount with foot
T00	0 cm M20 metric threaded tube for direct mount
T10	10 cm M20 metric threaded tube for direct mount
T25	25 cm M20 metric threaded tube for direct mount
Q10	10 cm quick release mount pole
Q25	25 cm quick release mount pole

b	
Network Option	
Code	Description
Blank	No network option

c	
Cable Connector and Length ⁽¹⁾	
Code	Description
SC20	Stranded cable, 2 m, yellow jacket
Blank	No cable (only for Q10 or Q25 base types)

(1) The SC20 cable must be ordered for all bases, except the Q10 and Q25 bases.

d	
Housing Color	
Code	Description
B	Black
G	Gray

e	
Voltage	
Code	Description
24	24V AC/DC
10	120V AC
20	240V AC

f	
Module Type ^{(1) (2)}	
Code	Description
Y	Steady LED
L	Flashing LED
C	Piezo sound alarm, continuous tone
P	Piezo sound alarm, pulsing tone
Q	Dual-circuit Piezo sound alarm ⁽³⁾

g	
Lens Color/Sound	
Code	Description
1	Sound module
3	Green
4	Red
5	Amber
6	Blue
7	Clear
8	Yellow

(1) Sound module types (C, P, Q) must be on the top-most level, they must be configured with Lens Color/Sound Code 1, and only one sound module is allowed per assembly.
 (2) Light module types (Y, L) can only be configured with Lens Color/Sound Codes 3, 4, 5, 6, 7, or 8.
 (3) If the dual circuit sound module (Q) is selected, the maximum number of light modules that are allowed is three (two circuits are required for the dual circuit sound module).

Specifications

Table 25 - Mechanical

Attribute		Value	
Standard Bases		Based on the weight and style of mounting; tower lights are subject to damage from shock and vibration. Listed below are reference guidelines for maximum acceptable conditions.	
		Shock [G]	Vibration [G]
Surface Mount Base or 10/25 cm Aluminum Pole Base	1 Module Stack	150	2.5
	3 Module Stack	45	2.5
	5 Module Stack	35	2.0

Table 26 - Environmental

Attribute		Value
Ingress Ratings	Light Modules	IP65/UL Type 4/4X/13
	Sound Modules	IP65/UL Type 4/4X/13
	Surface, Pole, Vertical, Tube Mount Bases	IP65/UL Type 4/4X/13
Temperature Ranges	Operating	-25...+50 °C (-13...+122 °F)
	Storage	-25...+85 °C (-13...+185 °F)

Table 27 - Materials

Attribute	Value
Bases, Caps, Lens Covers, Sound Module Housings	Polycarbonate
Rubber Seals and Gaskets	Nitrile rubber
Pole (for aluminum pole assembly)	Aluminum
Pole Base Footing (for aluminum pole base)	Polycarbonate
Insulation Sleeve (for pole insulation)	PVC
Mounting Screw Washers	Polyamide

Table 28 - Estimated Light Output⁽¹⁾ [mcd]

Attribute	Value
Steady, Flashing, Red	1000
Steady, Flashing, Amber	800
Steady, Flashing, Green	1500
Steady, Flashing, Yellow	700
Steady, Flashing, Blue	250
Steady, Flashing, White	1000

(1) Light Output values are calculated from the LED data sheet and show typical values of luminous density. These values are not exact because the knurling in the lens affects the light distribution and because the viewing angle of the LED that directly relates to the Cd output value, is not identical for all LEDs.

Table 29 - Operating Voltage

Attribute	Value		
	24V AC/DC	120V AC	240V AC
Light modules and sound modules	24V AC/DC (±10%)	110V AC, 50 Hz (±10%) 120V AC, 60 Hz (±10%)	230V AC, 50 (±10%) 240V AC, 60 (±10%)

Table 30 - Lamp Life Ratings (Design Life) Average Life Under Static, No Vibration, Conditions

Attribute	Value		
	24V AC/DC	120V AC	240V AC
LED modules	100,000 hr		
Sound modules	20,000 hr		

Table 31 - Current Consumption [mA]

Attribute		Value		
		24V AC/DC	120V AC	240V AC
Light modules	Steady or flashing LED	20	22	21
Piezo-style sound modules	Single- and dual-circuit	40	22	21

Table 32 - Flashing Frequency (Light Only Modules)

Attribute	Value
Flashing LED Modules	Flashing frequency approximately 2 Hz

Table 33 - Decibel Rating (Sound Modules) ⁽¹⁾

Attribute	Value
Piezo Sound Module	85 dB(A) (+2 dB/-5 dB)

(1) All dB(A) ratings determined at a distance of 1 meter from sound module.

Table 34 - Leakage Current Impact

All light and sound modules can absorb up to 3 mA of leakage current from solid-state outputs without module activation.

Standards Compliance

- UL 508
- CSA C22.2 No. 14
- EN/IEC 60947-1
- EN/IEC 60947-5-1

Certifications

- cULus Listed (File No. E14840, Guides NKCR, NKCR7)

Approximate Dimensions

Dimensions in millimeters (inches). Dimensions are not intended to be used for manufacturing purposes.

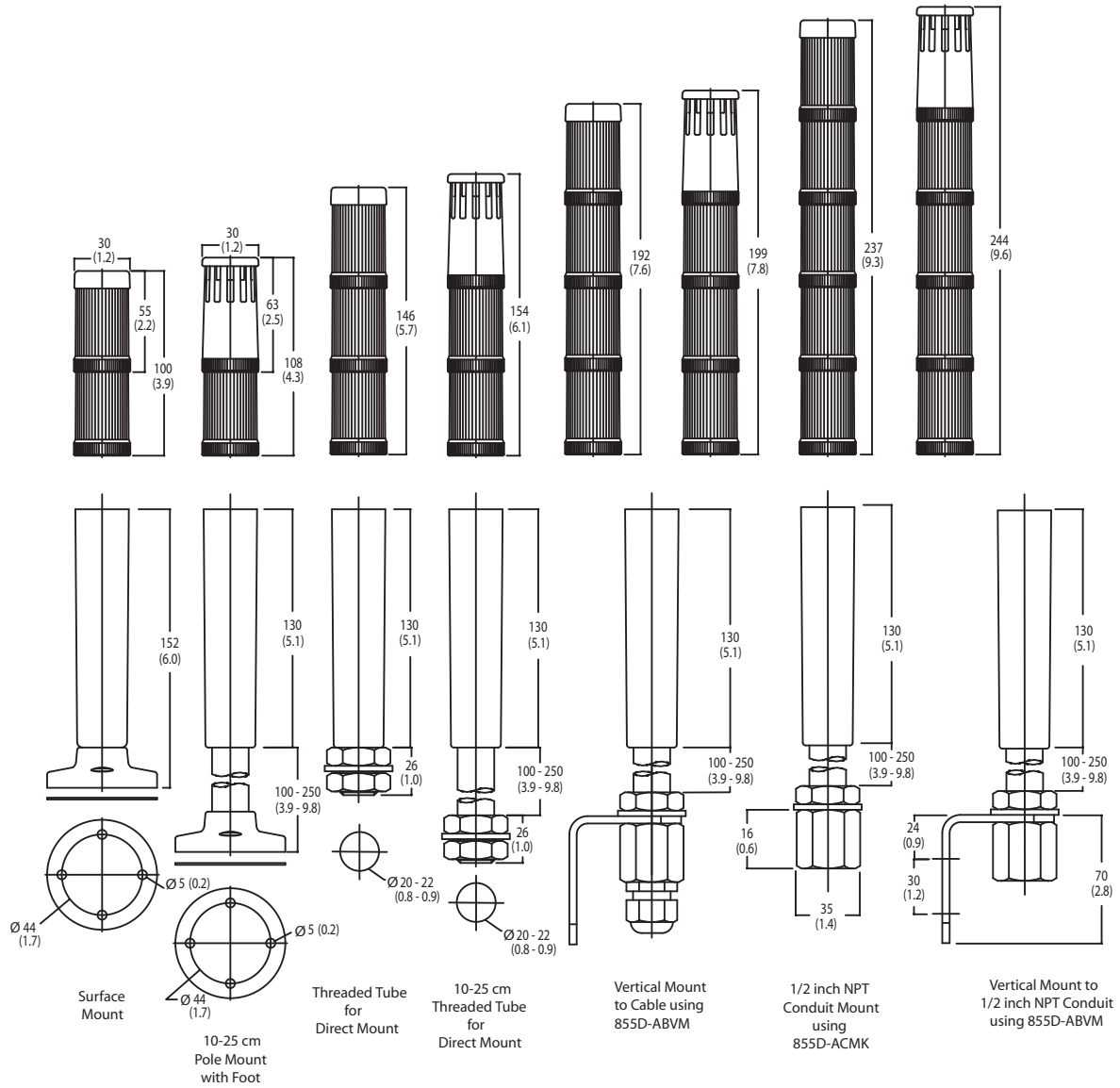

Bulletin 855F — 70 mm Compact Control Tower Stack Lights; Pre-Assembled and Pre-wired Tower Lights, One to Five Modules

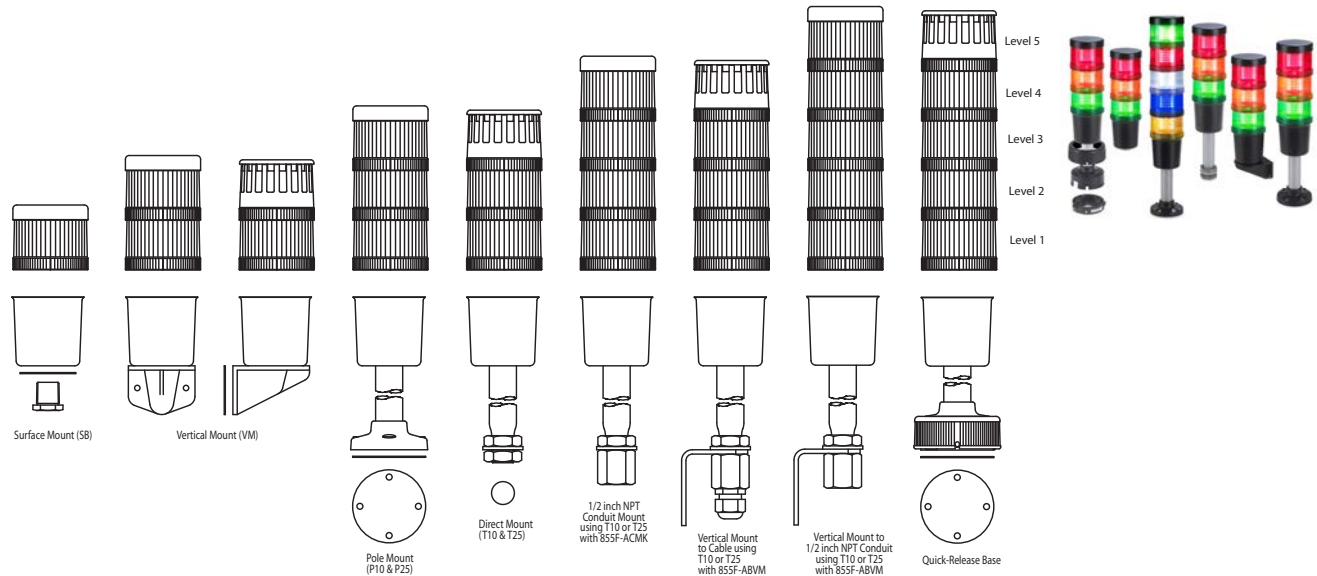

855F – P10 SC20 B 24 Y 3 Y 4 Y 5 L 7 P 1
 a b c d e f e f e f e f e f e f
 (Level 1, e+f) (Level 2, e+f) (Level 3, e+f) (Level 4, e+f) (Level 5, e+f)

a	
Base Type	
Code	Description
SB	Surface mount with 1/2 in. NPT threaded connector and mounting nut
P10	10 cm aluminum pole mount with foot
P25	25 cm aluminum pole mount with foot
T10	10 cm threaded tube for direct mount
T25	25 cm threaded tube for direct mount
VM	Vertical mount
Q10	10 cm quick release mount pole
Q25	25 cm quick release mount pole

b	
Cable Connector and Length ⁽¹⁾	
Code	Description
SC20	Stranded cable, 2 m, yellow jacket
Blank	No cable (only for Q10 or Q25 base types)

c	
Housing Color	
Code	Description
B	Black

(1) The SC20 cable must be ordered for all bases, except the Q10 and Q25 bases.

d	
Voltage	
Code	Description
24	24V AC/DC
10	120V AC
20	240V AC

e	
Module Type ^{(1) (2)}	
Code	Description
Y	Steady LED
L	Flashing LED
C	Piezo sound alarm, continuous tone
P	Piezo sound alarm, pulsing tone
Q	Dual-circuit Piezo sound alarm ⁽³⁾

f	
Lens Color/Sound	
Code	Description
1	Sound module
3	Green
4	Red
5	Amber
6	Blue
7	Clear
8	Yellow

(1) Sound module types (C, P, Q) must be on the top-most level, they must be configured with Lens Color/Sound Code 1, and only one sound module is allowed per assembly.
 (2) Light module types (Y, L) can only be configured with Lens Color/Sound Codes 3, 4, 5, 6, 7, or 8.
 (3) If the dual circuit sound module (Q) is selected, the maximum number of light modules that are allowed is three (two circuits are required for the dual circuit sound module).

Specifications

Table 35 - Mechanical

Attribute		Value	
Standard Bases		Based on the weight and style of mounting; tower lights are subject to damage from shock and vibration. Listed below are reference guidelines for maximum acceptable conditions.	
		Shock [G]	Vibration [G]
Surface Mount Base or 10/25 cm Aluminum Pole Base	1 Module Stack	150	2.5
	3 Module Stack	45	2.5
	5 Module Stack	35	2.0

Table 36 - Environmental

Attribute		Value
Ingress Ratings	Light Modules	IP65/UL Type 4/4X/13
	Sound Modules	IP65/UL Type 4/4X/13
	Surface, Pole, Vertical, Tube Mount Bases	IP65/UL Type 4/4X/13
Temperature Ranges	Operating	-25...+60 °C (-13...+140 °F)
	Storage	-25...+85 °C (-13...+185 °F)

Table 37 - Materials

Attribute	Value
Bases, Caps, Lens Covers, Sound Module Housings	Polycarbonate
Rubber Seals and Gaskets	Nitrile rubber
Pole (for aluminum pole assembly)	Aluminum
Pole Base Footing (for aluminum pole base)	Polycarbonate
Insulation Sleeve (for pole insulation)	PVC
Mounting Screw Washers	Polyamide

Table 38 - Estimated Light Output ⁽¹⁾[mcd]

Attribute	Value
Steady, Flashing, Red	1000
Steady, Flashing, Amber	800
Steady, Flashing, Green	1500
Steady, Flashing, Yellow	700
Steady, Flashing, Blue	250
Steady, Flashing, White	1000

(1) Light Output values are calculated from the LED data sheet and show typical values of luminous density. These values are not exact because the knurling in the lens affects the light distribution and because the viewing angle of the LED that directly relates to the Cd output value, is not identical for all LEDs.

Table 39 - Operating Voltage

Attribute	Value		
	24V AC/DC	120V AC	240V AC
Light modules and sound modules	24V AC/DC (±10%)	110V AC, 50 Hz (±10%) 120V AC, 60 Hz (±10%)	230V AC, 50 (±10%) 240V AC, 60 (±10%)

Table 40 - Lamp Life Ratings (Design Life) Average Life Under Static, No Vibration, Conditions

Attribute	Value		
	24V AC/DC	120V AC	240V AC
LED modules	100,000 hr		
Sound modules	20,000 hr		

Table 41 - Current Consumption [mA]

Attribute		Value		
		24V AC/DC	120V AC	240V AC
Light modules	Steady or flashing LED	20	22	21
Piezo-style sound modules	Single- and dual-circuit	53	22	21

Table 42 - Flashing Frequency (Light Only Modules)

Attribute	Value
Flashing LED Modules	Flashing frequency approximately 2 Hz

Table 43 - Decibel Rating (Sound Modules) ⁽¹⁾

Attribute	Value
Piezo Sound Module	100 dB(A) (+2 dB/-5 dB)

(1) All dB(A) ratings determined at a distance of 1 meter from sound module.

Table 44 - Leakage Current Impact

All light and sound modules can absorb up to 3 mA of leakage current from solid-state outputs without module activation.

Standards Compliance

- UL 508
- CSA C22.2 No. 14
- EN/IEC 60947-1
- EN/IEC 60947-5-1

Certifications

- cULus Listed (File No. E14840, Guides NKCR, NKCR7)
- CE Marked

Approximate Dimensions

Dimensions in millimeters (inches). Dimensions are not intended to be used for manufacturing purposes.

Assembled Stacks

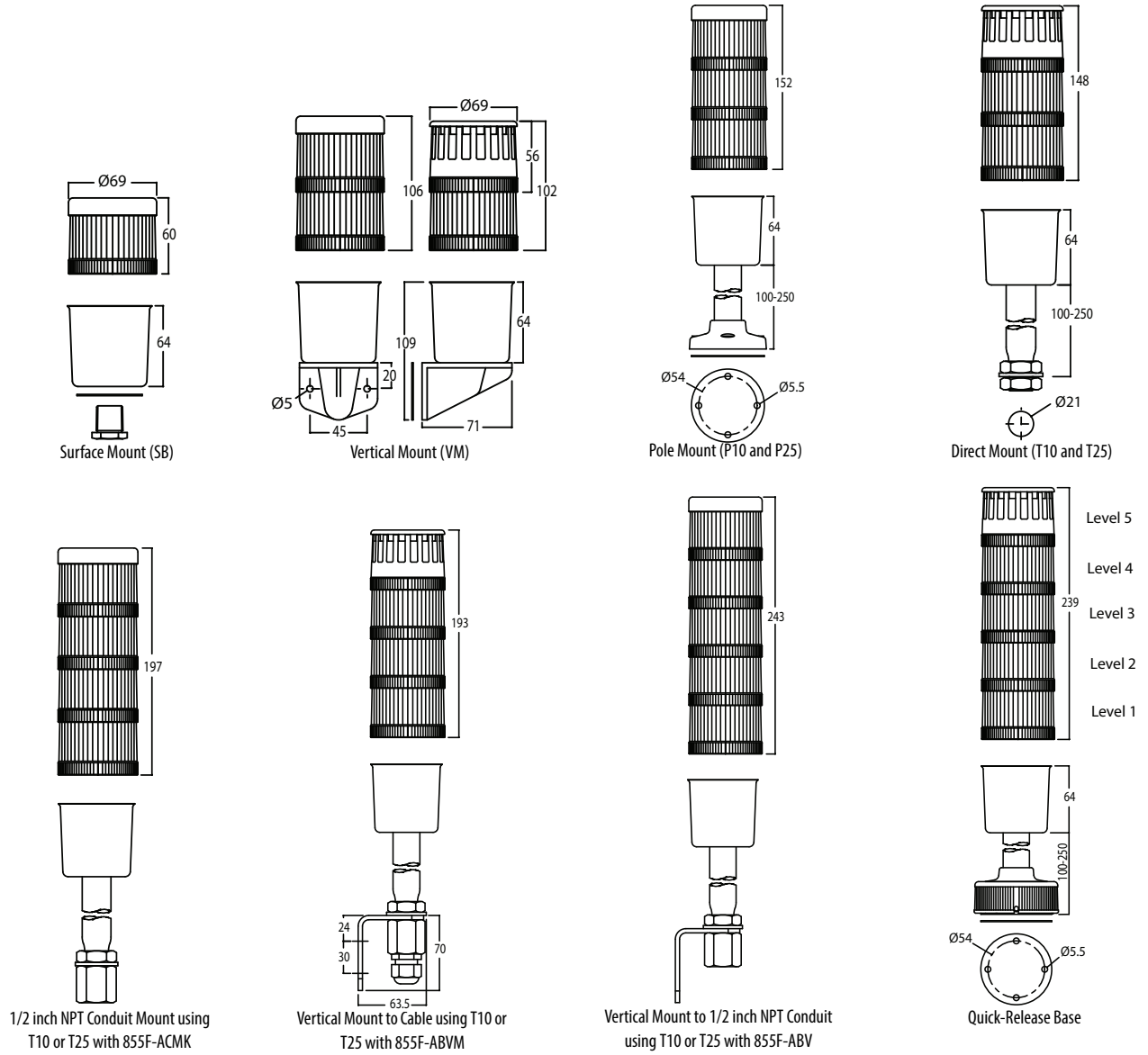

Bulletin 854J — 40 mm Control Tower Stack Lights

Light Modules



Steady LED Module

854J – $\frac{10}{a}$ $\frac{TL}{b}$ $\frac{4}{c}$

a	
Voltage	
Code	Description
00	0...250V AC/DC (no-lamp module ⁽¹⁾)
24	24V AC/DC ⁽²⁾
10	120V AC ⁽²⁾
20	240V AC ⁽²⁾

b	
Light Module Type	
Code	Description
XN	Steady no lamp ⁽³⁾
TL	Steady LED
GL	Flashing LED
BL	LED strobe, single flash

c	
Lens Color	
Code	Description
3	Green
4	Red
5	Amber
6	Blue
7	Clear
8	Yellow

- (1) Can only be selected with module type XN, voltage code 00. Accepts 4 W socket mount incandescent lamp types only.
- (2) Not valid with module type XN.
- (3) Incandescent lamps (catalog numbers 854J-L24, 854J-L10, and 854J-L20) must be purchased separately.

Sound Modules

Sound modules have continuous and pulsing tones selectable via DIP switch. Maximum sound output is 80 dB(A) @ 1 meter.



Sound Module

854J – $\frac{B}{a}$ $\frac{10}{b}$ $\frac{SA3}{c}$

a	
Housing Color	
Code	Description
B	Black

b	
Light Module Type	
Code	Description
24	24V AC/DC
10	120V AC
20	240V AC

c	
Module Type	
Code	Description
SA3	Single circuit piezo style steady/pulsing DIP switch selectable

Standard Stack Light Bases



854J – $\frac{B}{a}$ $\frac{VM}{b}$ $\frac{C}{c}$

a	
Housing Color	
Code	Description
B	Black

b	
Base Type ⁽¹⁾	
Code	Description
NPT	1/2 in. NPT
VM	Vertical mount
SH	Surface mount, preinstalled mounting hardware
SF	Surface mount, external mounting holes
PM10	10 cm aluminum pole mount base
PM25	25 cm aluminum pole mount base
T10	10 cm threaded tube (M20)
T25	25 cm threaded tube (M20)
DS	Double-sided base ⁽²⁾
Q10	10 cm quick release base
Q25	25 cm quick release base
SFQD5	Flange-style base with M12 (5-pin DC) micro connector ^{(3) (4) (5) (6) (7)}

c	
Cap Option	
Code	Description
C	Cap included

- (1) PM10, PM25, T10, T25, Q10, and Q25 bases have powder-coated aluminum tubes
- (2) Double-sided base can accommodate up to ten modules per base divided in two groups up to five levels each.
- (3) For vertical mounting of the base use catalog number 855T-AVM.
- (4) Maximum number of levels that are allowed in the stack is four.
- (5) For use with Bulletin 889D cordsets.
- (6) Cannot be used with 10 cm plastic base extension (catalog number 854J-ABBE).
- (7) Maximum 250V AC/DC UL / 60V AC/DC IEC.

Pre-Configured Tower Lights, One to Five Modules

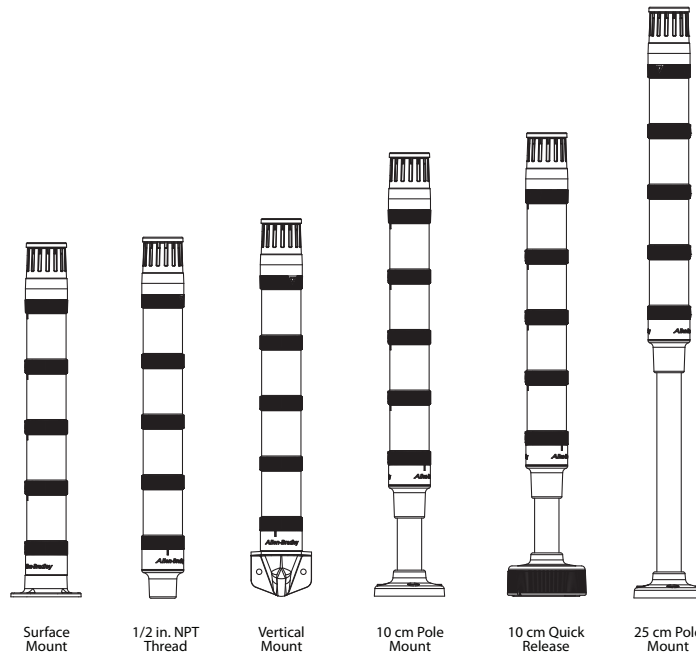

854JC – SF B 10 Y 3 L 5 B 3 L 7 Y 6
 a b c d c d c d c d c d
 (Level 1, c+d) (Level 2, c+d) (Level 3, c+d) (Level 4, c+d) (Level 5, c+d)

a	
Base Type ⁽¹⁾	
Code	Description
NPT	1/2 in. NPT
VM	Vertical mount
SF	Surface mount —external mounting holes
P10	10 cm aluminum pole mount with foot
P25	25 cm aluminum pole mount with foot
Q10	10 cm quick release mount pole
Q25	25 cm quick release mount pole

b	
Voltage	
Code	Description
24	24V AC/DC
10	120V AC

c	
Module Type	
Code	Description
Y	Steady LED
L	Flashing LED
B	Strobe LED—single flash
P	Piezo sound alarm, continuous/pulsing tone

d	
Lens Color/Sound	
Code	Description
1	Sound module ⁽²⁾
3	Green
4	Red
5	Amber
6	Blue
7	Clear
8	Yellow

(1) P10, P25, Q10, Q25 bases have powder-coated aluminum tubes.
 (2) Sound module option can only be selected with Module Type option P in Table e. They must be located in the top position of the stack.

Specifications

Table 45 - Mechanical

Attribute		Value	
Standard Bases		Based on the weight and style of mounting; tower lights are subject to damage from shock and vibration. Listed below are reference guidelines for maximum acceptable conditions.	
		Shock [G]	Vibration [G]
Surface Mount Base or 10 cm Aluminum Pole Base	1 Module Stack	50	5
	3 Module Stack	50	5
	5 Module Stack	40	5
Vertical Base or 25 cm Aluminum Pole Base	1 Module Stack	55	5
	3 Module Stack	55	5
	5 Module Stack	35	5
Recommended Wire Sizes		0.2...1.5 mm ² (24...16 AWG)	
Recommended Terminal Torque		Screwless terminal blocks	

Table 46 - Environmental

Attribute		Value
Ingress Ratings	Light Modules	IP65/UL Type 4/4X/13
	Sound Modules	
	Surface, Vertical, Tube Mount Bases	
	Pole Mount Bases	
	Flange-style Base with M12 Micro Connector ⁽¹⁾	
Temperature Ranges	Operating	-30...+60 °C (-22...+140 °F) For Cat. No. 854J-BSFQD5C only: -30...+45 °C (-22...+113 °F)
	Storage	-30...+85 °C (-22...+185 °F)

(1) UL Type 1 when used with Cat. No. 855T-AVM mounting bracket.

Table 47 - Materials

Attribute	Value
Bases, Caps, Lens Covers, Sound Module Housings	Polycarbonate
Lamp Socket	Polycarbonate
Rubber Seals and Gaskets	Nitrile rubber
Pole (for aluminum pole assembly)	Aluminum
Pole Base Footing (for aluminum pole base)	Polycarbonate
Mounting Screw Washers	Polypropylene

Table 48 - Estimated Light Output [mcd]

Attribute		Value	
		24V AC/DC	120V AC, 240V AC
Strobe LED	Red	4430	3915
	Green	4216	4080
	Amber	4430	3915
	Blue	1673	1619
	Clear	4464	4320
	Yellow	3715	3283
Steady/Flashing LED	Red	1793	2392
	Green	1714	3400
	Amber	1793	2391
	Blue	680	1349
	Clear	1814	3600
	Yellow	1503	2006

Table 49 - Operating Voltage

Attribute	Value		
	24V AC/DC	120V AC	240V AC
Light modules and sound modules	24V AC/DC (±10%)	110V AC, 50 Hz (±10%) 120V AC, 60 Hz (±10%)	230V AC, 50 (±10%) 240V AC, 60 (±10%)

Table 50 - Lamp Life Ratings (Design Life) Average Life Under Static, No Vibration, Conditions

Attribute	Value		
	24V AC/DC	120V AC	240V AC
LED modules	50,000 hr		
Sound modules	20,000 hr		

Table 51 - Current Consumption [mA]

Attribute		Value		
		24V AC/DC	120V AC	240V AC
Light only modules	Steady LED	22 (red, amber, and yellow) 33 (green, blue, and white)	30 (red, amber, and yellow) 29 (green, blue, and white)	
		Flashing LED	28 (red, amber, and yellow) 36 (green, blue, and white)	30 (red, amber, and yellow) 29 (green, blue, and white)
	Strobe LED		35 (red, amber, and yellow) 65 (green, blue, and white)	10
Sound modules	Single-tone	65	31	32

Table 52 - Flashing Frequency (Light Only Modules)

Attribute	Value
Flashing LED Modules	Approximately 1.5 Hz; Time On/Time OFF = 1:1
LED Strobe Modules	Approximately 2 Hz (flash duration 1/50,000 second)

Table 53 - Decibel Rating (Sound Modules) ⁽¹⁾

Attribute	Value
Single-tone Sound Module	80 dB(A) (non-adjustable)

(1) All dB(A) ratings determined at a distance of 1 meter from sound module.

Table 54 - Leakage Current Impact

All light and sound modules can absorb up to 3 mA of leakage current from solid-state outputs without module activation.

Standards Compliance

- UL 508
- CSA C22.2 No. 14
- EN/IEC 60947-1
- EN/IEC 60947-5-1

Certifications

- cULus Listed (File No. E14840, Guides NKCR, NKCR7)
- CE Marked
- RoHS Compliant

Approximate Dimensions

Dimensions in millimeters (inches). Dimensions are not intended to be used for manufacturing purposes.

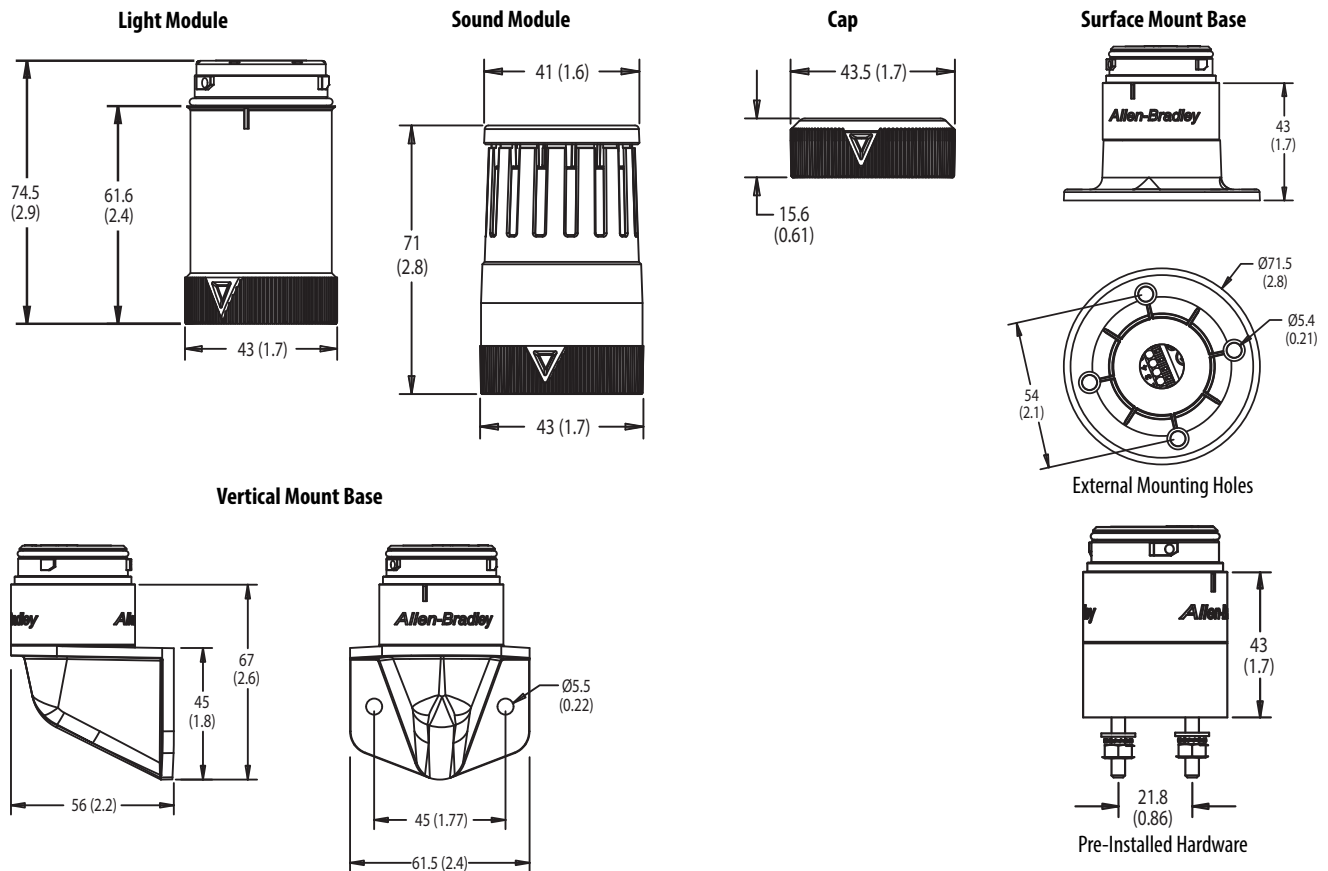

Dimensions in millimeters (inches). Dimensions are not intended to be used for manufacturing purposes.

Quick-Release Base

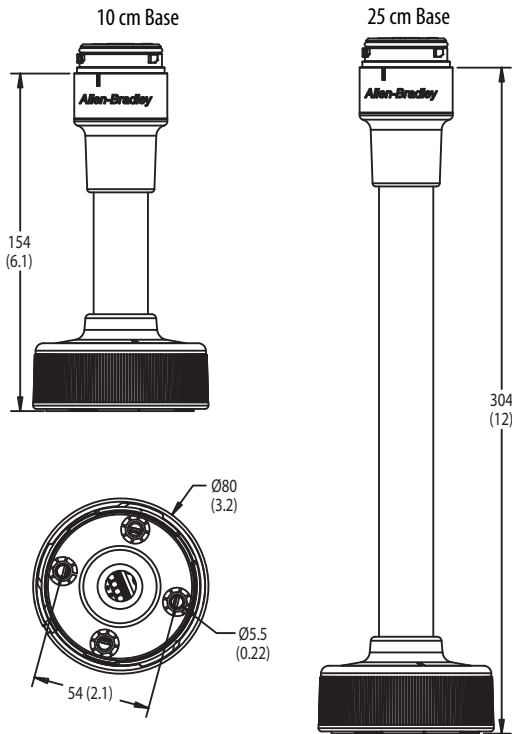

Pole Mount Bases

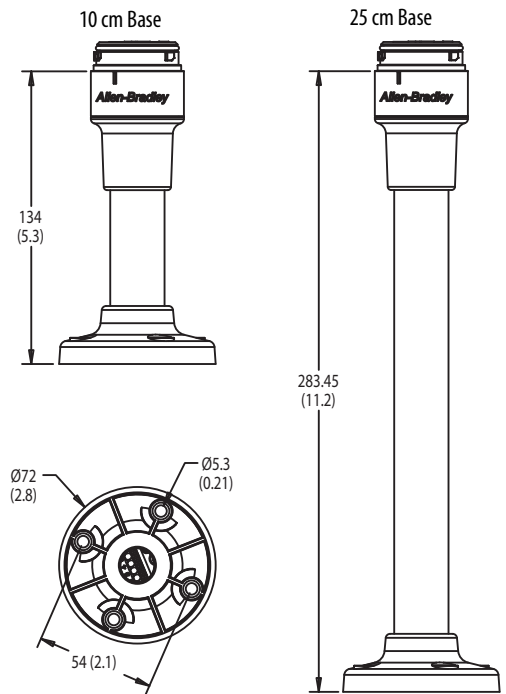

1/2 in. NPT Thread Base

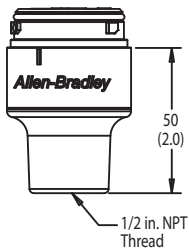

Double-Sided Base

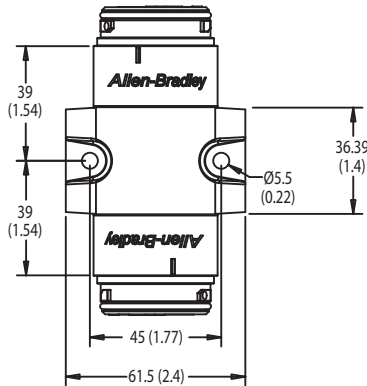

Flange-style Base with M12 Micro Connector (Male)

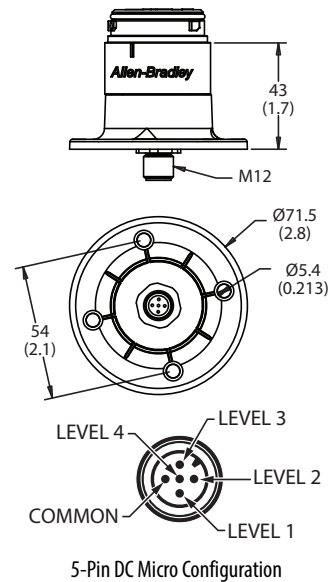

Bulletin 855E — 50 mm Control Tower Stack Lights

Light Modules



Flashing Incandescent

855E - $\frac{10}{a}$ $\frac{FN}{b}$ $\frac{4}{c}$

a	
Voltage	
Code	Description
00	0...250V AC/DC (no-lamp module ⁽¹⁾)
12	12V AC/DC
24	24V AC/DC
10	120V AC
20	240V AC

b	
Light Module Type	
Code	Description
XN	Steady no lamp ⁽¹⁾
DN	Steady incandescent
FN	Flashing incandescent
TL	Steady socket-mount LED
GL	Flashing socket-mount LED
BL	Strobe

c	
Lens Color	
Code	Description
3	Green
4	Red
5	Amber
6	Blue
7	Clear
8	Yellow

(1) Can only be selected with module type XN, voltage code 00. Accepts socket mount incandescent lamp types only.

Sound Modules

Sound modules have continuous and pulsing tones. Maximum sound output is 103 dB @ 1 meter. A reduced volume setting is available by changing the position of the volume DIP switch, producing a sound output of 88 dB(A) @ 1 meter. Maximum sound output is 80 dB(A) @ 1 meter.



Black Two-Tone Sound Module

855E - $\frac{B}{a}$ $\frac{10}{b}$ $\frac{TA3}{c}$

a	
Housing Color	
Code	Description
B	Black
G	Gray

b	
Voltage	
Code	Description
12	12V AC/DC
24	24V AC/DC
10	120V AC
20	240V AC

c	
Module Type	
Code	Description
SA3	Single circuit/single tone piezo style steady/pulsing DIP switch selectable
TA	Two circuit/two-tone piezo style steady/pulsing DIP switch selectable

Standard Stack Light Bases



Surface-Mount Base with Cap



Vertical-Mount Base with Cap



Pole-Mount Bases



Quick Release Base

855E – $\frac{B}{a}$ $\frac{VM}{b}$ $\frac{C}{c}$

a	
Housing Color	
Code	Description
B	Black
G	Gray

b	
Base Type	
Code	Description
CB	Surface mount with 1/2 in. NPT threading
RB	Surface mount with M20 metric threading
SB	Surface mount with PG16 threading
TM	25 mm tube mount
VM	Vertical mount
PM10	10 cm aluminum pole mount base
PM25	25 cm aluminum pole mount base
PM40	40 cm aluminum pole mount base
PM60	60 cm aluminum pole mount base
PM80	80 cm aluminum pole mount base
MM10	10 cm quick release base
MM25	25 cm quick release base
MM40	40 cm quick release base

c	
Cap Option ⁽¹⁾	
Code	Description
Blank	No cap
C	Cap included

(1) Quick-release bases always include a cap.

Pre-Configured Tower Lights, One to Five Modules

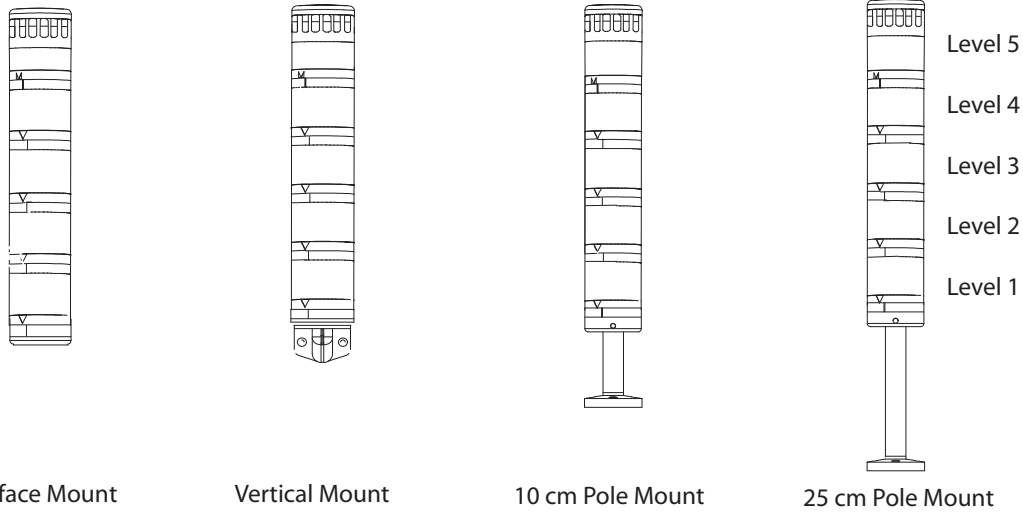

855 - EC B 10 Y 3 L 5 B 3 F 7 Y 6
 a b c d e d e d e d e d e
 (Level 1, d+e) (Level 2, d+e) (Level 3, d+e) (Level 4, d+e) (Level 5, d+e)

a	
Base Type	
Code	Description
EC	Surface mount - 1/2 in. NPT threading
ES	Surface mount - PG16
EV	Vertical mount
EM	25 mm tube mount
EP	10 cm pole mount
EE	25 cm pole mount

b	
Base & Cap Color	
Code	Description
B	Black
G	Gray

c	
Voltage	
Code	Description
12	12V AC/DC
24	24V AC/DC
10	120V AC
20	240V AC

d	
Module Type	
Code	Description
D	Steady incandescent
F	Flashing incandescent
Y	Steady LED
L	Flashing LED
B	Strobe
P	Single-circuit piezo sound module
Q	Two-circuit piezo sound module ⁽¹⁾

e	
Lens Color/Sound	
Code	Description
1	Sound module ⁽²⁾
3	Green
4	Red
5	Amber
6	Blue
7	Clear
8	Yellow

(1) If the two-circuit sound module (option Q in Table d) is selected, the maximum number of light modules that are allowed is three.
 (2) Sound module option can only be selected with Module Type option P or Q in Table d. They must be located in the top position of the stack.

Specifications

Table 55 - Mechanical

Attribute		Value	
Standard Bases		Based on the weight and style of mounting; tower lights are subject to damage from shock and vibration. Listed below are reference guidelines for maximum acceptable conditions.	
		Shock [G]	Vibration [G]
Surface Mount Base or 10 cm Aluminum Pole Base	1 Module Stack	150	5
	3 Module Stack	45	1.5
	5 Module Stack	35	0.75
Vertical Base or 25 cm Aluminum Pole Base	1 Module Stack	95	3.5
	3 Module Stack	30	1.25
	5 Module Stack	20	0.5
Recommended Wire Sizes		0.5...1.5 mm ² (22...16 AWG)	
Recommended Terminal Torque		0.87 N·m (7 lb·in)	

Table 56 - Environmental

Attribute		Value
Ingress Ratings	Light Modules with Cap	IP66/UL Type 4/4X/13
	Sound Modules	IP66/UL Type 4/4X/13
	Surface, Vertical, Tube Mount Bases	IP66/UL Type 4/4X/13
	Pole Mount Bases	IP66/UL Type 4/4X/13
	Flange-style Base with M12 Micro Connector ⁽¹⁾	IP66/UL Type 4/4X/13
Temperature Ranges	Operating	-25...+50 °C (-13...+122 °F)
	Storage	-40...+85 °C (-40...+185 °F)

(1) UL Type 1 when used with Cat. No. 855T-AVM mounting bracket.

Table 57 - Materials

Attribute	Value
Bases, Caps, Lens Covers, Sound Module Housings, Lenses	Polycarbonate
Lamp Socket	Polycarbonate
Rubber Seals and Gaskets	Nitrile rubber
Pole (for aluminum pole assembly)	Aluminum
Pole Base Footing (for aluminum pole base)	Polycarbonate
Insulation Sleeve (for pole insulation)	Polyolefin
Mounting Screw Washers	Polypropylene

Table 58 - Light Output

Attribute	Value			
	12V AC/DC	24V AC/DC	120V AC	240V AC
Steady Incandescent	0.5 MSCP	2.5 MSCP	3.0 MSCP	0.49 MSCP
Flashing Incandescent	6.3 Lumens	31.4 Lumens	37.7 Lumens	6.2 Lumens
Strobe	1 J per lamp			
Steady, Flashing Socket Mount LED	Red	900...2240 mcd		
	Green	900...1800 mcd		
	Amber	1400...3550 mcd		
	Blue	224...560 mcd		
	White and Yellow	900...1800 mcd		

Table 59 - Operating Voltage

Attribute	Value			
	12V AC/DC	24V AC/DC	120V AC	240V AC
Light modules and sound modules	12V AC/DC (±10%)	24V AC/DC (±10%)	110V AC, 50 Hz (±10%) 120V AC, 60 Hz (±10%)	230V AC, 50 (±10%) 240V AC, 60 (±10%)

Table 60 - Lamp Life Ratings (Design Life) Average Life Under Static, No Vibration, Conditions

Attribute	Value			
	12V AC/DC	24V AC/DC	120V AC	240V AC
Incandescent Modules ^{(1) (2)}	8000 hr	7000 hr	3000 hr	1600 hr
LED Modules	100,000 hr			
Strobe Modules	15,000 hr			
Sound modules	20,000 hr			

(1) First failures at about 35% of average life. Severe vibration can reduce life to 44% of average life.

(2) Flashing applications can reduce life to 50% of average life.

Table 61 - Current Consumption [mA]

Attribute		Value		
		24V AC/DC	120V AC	240V AC
Light only modules	Steady LED	22 (red, amber, and yellow) 33 (green, blue, and white)	30 (red, amber, and yellow) 29 (green, blue, and white)	
	Flashing LED	28 (red, amber, and yellow) 36 (green, blue, and white)	30 (red, amber, and yellow) 29 (green, blue, and white)	
	Strobe LED	35 (red, amber, and yellow) 65 (green, blue, and white)	10	
Sound modules	Single-tone	65	31	32

Table 62 - Flashing and Tone Frequency

Attribute	Value
Flashing Frequency (Light Only Modules)	
Flashing Incandescent Modules	12V module approximately 1.5 Hz 24V, 120V, and 240V modules approximately 2 Hz Time ON/Time OFF = 1:1
Flashing LED Modules	Approximately 1.5 Hz; Time On/Time OFF = 1:1
LED Strobe Modules	Approximately 2 Hz (flash duration 1/50,000 second)
Flashing and Tone Frequency (Light Modules/with Sound Set at Continuous Tone)	
Tone Frequency	Tone frequency is preset at 2800 Hz
Flashing and Tone Pulsing Frequencies (Light Modules/with Sound Set at Pulsing Tone)	
Tone Frequency	Tone frequency is preset at 2800 Hz

Table 63 - Decibel Rating (Sound Modules) ⁽¹⁾

Attribute	Value
Single-tone Sound Module (SA3)	Maximum volume ranges from 88 or 103 dB(A) (volume adjustable by DIP switch)
Two-tone Sound Module (TA3)	

(1) All dB(A) ratings determined at a distance of 1 meter from sound module.

Table 64 - Leakage Current Impact

All light and sound modules can absorb up to 3 mA of leakage current from solid-state outputs without module activation.

Standards Compliance

- UL 508
- EN/IEC 60947-1
- CSA C22.2 No. 14
- EN/IEC 60947-5-1

Certifications

- cULus Listed (File No. E14840, Guides NKCR, NKCR7)
- CE Marked

Approximate Dimensions

Dimensions in millimeters (inches). Dimensions are not intended to be used for manufacturing purposes.

Light Modules

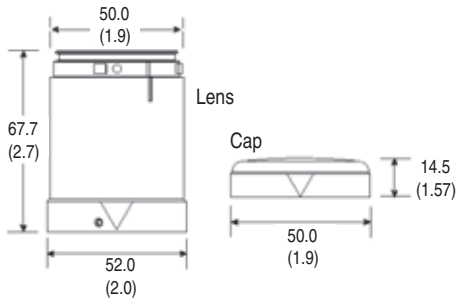

Vertical Mount Base

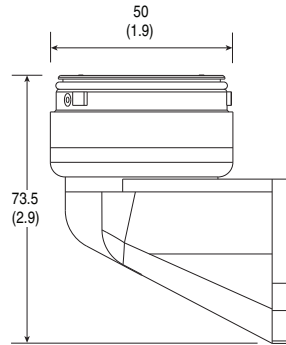

Sound Module

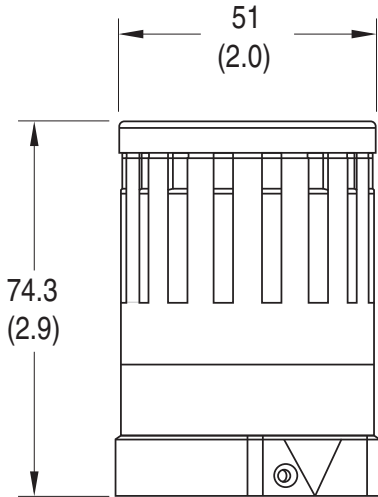

Surface Mount Base

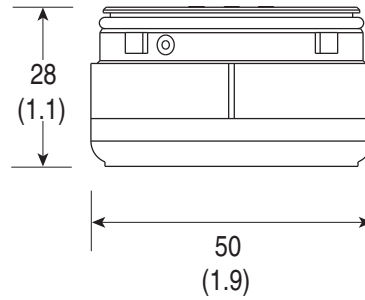

Quick Release Base

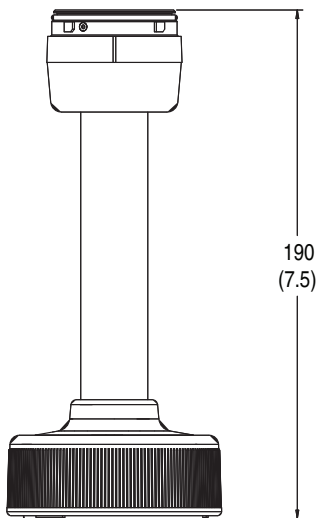

Pole Mount Bases

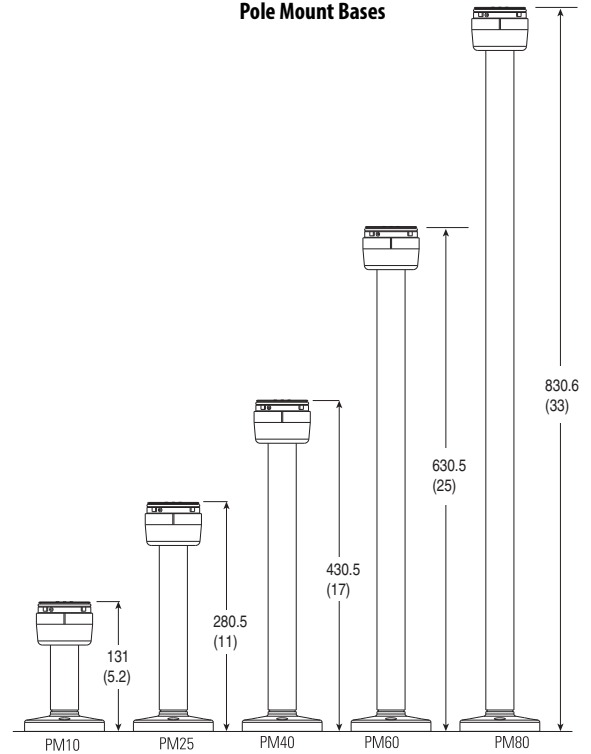

Bulletin 854K— 60 mm Control Tower Stack Lights

Light Modules



Steady LED Module

854K – $\frac{10}{a} \quad \frac{TL}{b} \quad \frac{4}{c}$

a	
Voltage	
Code	Description
00	0...250V AC/DC (no-lamp module ⁽¹⁾)
24	24V AC/DC ⁽²⁾
10	120V AC ⁽²⁾
20	240V AC ⁽²⁾

b	
Light Module Type	
Code	Description
XN	Steady no lamp ⁽³⁾
TL	Steady socket-mount LED
GL	Flashing socket-mount LED
BL	LED strobe, single flash

c	
Lens Color	
Code	Description
3	Green
4	Red
5	Amber
6	Blue
7	Clear
8	Yellow

- (1) Can only be selected with module type XN, voltage code 00. Accepts socket mount incandescent lamp types only.
- (2) Not valid with module type XN.
- (3) Incandescent lamps (catalog numbers 854J-L24, 854J-L10, and 854J-L20) must be purchased separately.

Sound Modules

Sound modules have continuous and pulsing tones selectable via DIP switch. Maximum sound output is 90 dB(A) @ 1 meter and the volume is adjustable.



Sound Module

854K – $\frac{B}{a} \quad \frac{10}{b} \quad \frac{SA3}{c}$

a	
Housing Color	
Code	Description
B	Black

b	
Voltage	
Code	Description
24	24V AC/DC
10	120V AC
20	240V AC

c	
Module Type	
Code	Description
SA3	Single circuit/single tone piezo style steady/pulsing DIP switch selectable

Standard Stack Light Bases



854K – $\frac{B}{a} \frac{VM}{b} \frac{C}{c}$

a	
Housing Color	
Code	Description
B	Black

b	
Base Type ⁽¹⁾	
Code	Description
NPT	1/2 in. NPT threading
VM	Vertical mount
SH	Surface mount, preinstalled mounting hardware
SF	Surface mount, external mounting holes
PM10	10 cm aluminum pole mount base
PM25	25 cm aluminum pole mount base
T10	10 cm threaded tube (M20)
T25	25 cm threaded tube (M20)
DS	Double-sided base ⁽²⁾
Q10	10 cm quick release base
Q25	25 cm quick release base
SFQD5	Flange-style base with M12 (5-pin DC) micro connector ^{(3) (4) (5) (6) (7)}

c	
Cap Option	
Code	Description
C	Cap included

- (1) PM10, PM25, T10, T25, Q10, and Q25 bases have powder-coated aluminum tubes.
- (2) Double-sided base can accommodate up to ten modules per base divided in two groups up to five levels each.
- (3) For vertical mounting of the base use catalog number 854K-AVM.
- (4) Maximum number of levels that are allowed in the stack is four.
- (5) For use with Bulletin 889D cordsets.
- (6) Cannot be used with 10 cm plastic base extension (catalog number 854K-ABBE).
- (7) Maximum 250V AC/DC UL / 60V AC/DC IEC.

Pre-Configured Tower Lights, One to Five Modules

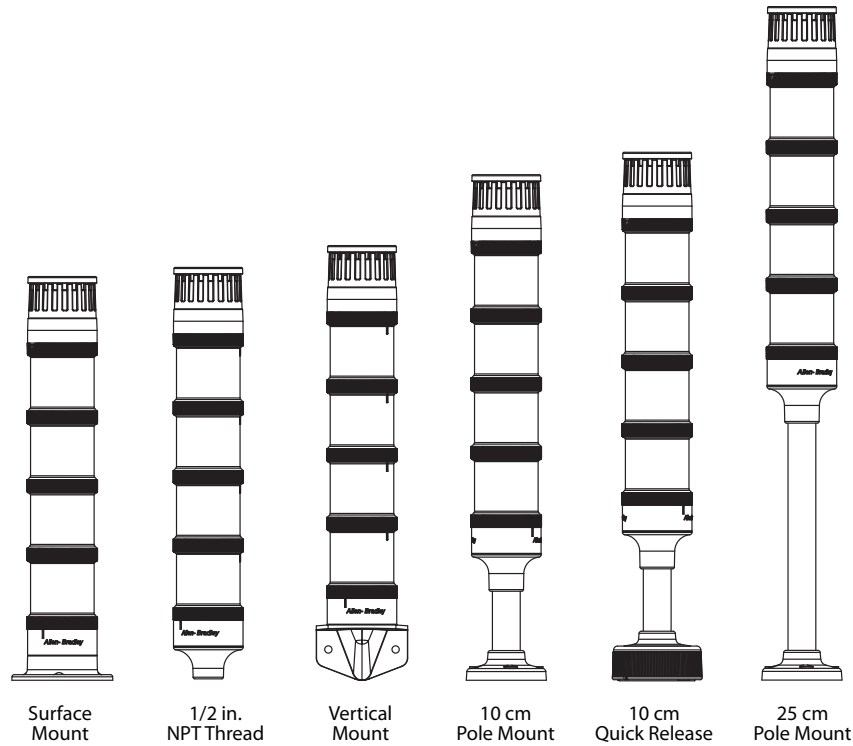

854KC – SF B 10 Y 3 L 5 B 3 F 7 Y 6
 a b c d c d c d c d c d
 (Level 1, c+d) (Level 2, c+d) (Level 3, c+d) (Level 4, c+d) (Level 5, c+d)

a	
Base Type ⁽¹⁾	
Code	Description
NPT	1/2 in. NPT
VM	Vertical mount
SF	Surface mount — external mounting holes
P10	10 cm aluminum pole mount
P25	25 cm aluminum pole mount
Q10	10 cm quick release base
Q25	25 cm quick release base

b	
Voltage	
Code	Description
24	24V AC/DC
10	120V AC

c	
Module Type	
Code	Description
Y	Steady LED
L	Flashing LED
B	Strobe
P	Single-circuit piezo sound module

d	
Lens Color/Sound	
Code	Description
1	Sound module ⁽²⁾
3	Green
4	Red
5	Amber
6	Blue
7	Clear
8	Yellow

(1) P10, P25, Q10, and Q25 bases have powder-coated aluminum tubes.

(2) Sound module option can only be selected with Module Type option P in Table c. They must be located in the top position of the stack.

Specifications

Table 65 - Mechanical

Attribute		Value	
Standard Bases		Based on the weight and style of mounting; tower lights are subject to damage from shock and vibration. Listed below are reference guidelines for maximum acceptable conditions.	
		Shock [G]	Vibration [G]
Surface Mount Base with external holes or 10 cm Aluminum Pole Base	1 Module Stack	50	5
	3 Module Stack	50	5
	5 Module Stack	40	5
Vertical Base or 25 cm Aluminum Pole Base	1 Module Stack	55	5
	3 Module Stack	55	5
	5 Module Stack	35	5
Recommended Wire Sizes		0.2...1.5 mm ² (24...16 AWG)	
Recommended Terminal Torque		Screwless terminal blocks	

Table 66 - Environmental

Attribute		Value
Ingress Ratings	Light Modules with Cap	IP66/UL Type 4/4X/13
	Sound Modules	IP66/UL Type 4/4X/13
	Surface, Vertical, Tube Mount Bases	IP66/UL Type 4/4X/13
	Pole Mount Bases	IP66/UL Type 4/4X/13
	Flange-style Base with M12 Micro Connector ⁽¹⁾	IP66/UL Type 4/4X/13
Temperature Ranges	Operating	-30...+60 °C (-22...+140 °F) For Cat. No. 854J-BSFQD5C only: -30...+45 °C (-22...+113 °F)
	Storage	-30...+85 °C (-22...+185 °F)

(1) UL Type 1 when used with Cat. No. 855K-AVM mounting bracket.

Table 67 - Materials

Attribute	Value
Bases, Caps, Lens Covers, Sound Module Housings, Lenses	Polycarbonate
Lamp Socket	Polycarbonate
Rubber Seals and Gaskets	Nitrile rubber
Pole (for aluminum pole assembly)	Aluminum
Pole Base Footing (for aluminum pole base)	Polycarbonate
Mounting Screw Washers	Polypropylene

Table 68 - Light Output [mcd]

Attribute		Value	
		24V AC/DC	120V AC, 240V AC
Strobe LED	Red	4430	3915
	Green	4216	4080
	Amber	4430	3915
	Blue	1673	1619
	White	4464	4320
	Yellow	3715	3283
Steady/Flashing LED	Red	1793	2392
	Green	1714	3400
	Amber	1793	2392
	Blue	680	1349
	White	1814	3600
	Yellow	1503	2006

Table 69 - Operating Voltage

Attribute	Value		
	24V AC/DC	120V AC	240V AC
Light modules and sound modules	24V AC/DC ($\pm 10\%$)	110V AC, 50 Hz ($\pm 10\%$) 120V AC, 60 Hz ($\pm 10\%$)	230V AC, 50 ($\pm 10\%$) 240V AC, 60 ($\pm 10\%$)

Table 70 - Lamp Life Ratings (Design Life) Average Life Under Static, No Vibration, Conditions

Attribute	Value		
	24V AC/DC	120V AC	240V AC
LED Modules		50,000 hr	
Sound modules		20,000 hr	

Table 71 - Current Consumption [mA]

Attribute		Value		
		24V AC/DC	120V AC	240V AC
Light only modules	Steady LED	22 (red, amber, and yellow) 33 (green, blue, and white)	30 (red, amber, and yellow) 29 (green, blue, and white)	
		28 (red, amber, and yellow) 36 (green, blue, and white)	30 (red, amber, and yellow) 29 (green, blue, and white)	
	Strobe LED	35 (red, amber, and yellow) 65 (green, blue, and white)	10	
Sound modules	Single-tone	65	31	32

Table 72 - Flashing Frequency (Light Only Modules)

Attribute	Value
Flashing LED Modules	Approximately 1.5 Hz; Time On/Time OFF = 1:1
LED Strobe Modules	Approximately 2 Hz (flash duration 1/50,000 second)

Table 73 - Tone Frequency

Attribute	Value
Tone Frequency	Preset at 2500 Hz

Table 74 - Decibel Rating (Sound Modules) ⁽¹⁾

Attribute	Value
Single-tone Sound Module (SA3)	Maximum volume output is 80 dB(A) (non-adjustable)

(1) All dB(A) ratings determined at a distance of 1 meter from sound module.

Table 75 - Leakage Current Impact

All light and sound modules can absorb up to 3 mA of leakage current from solid-state outputs without module activation.

Standards Compliance

- UL 508
- CSA C22.2 No. 14
- EN/IEC 60947-1
- EN/IEC 60947-5-1

Certifications

- cULus Listed (File No. E14840, Guides NKCR, NKCR7)
- CE Marked
- RoHS Compliant

Approximate Dimensions

Dimensions in millimeters (inches). Dimensions are not intended to be used for manufacturing purposes.

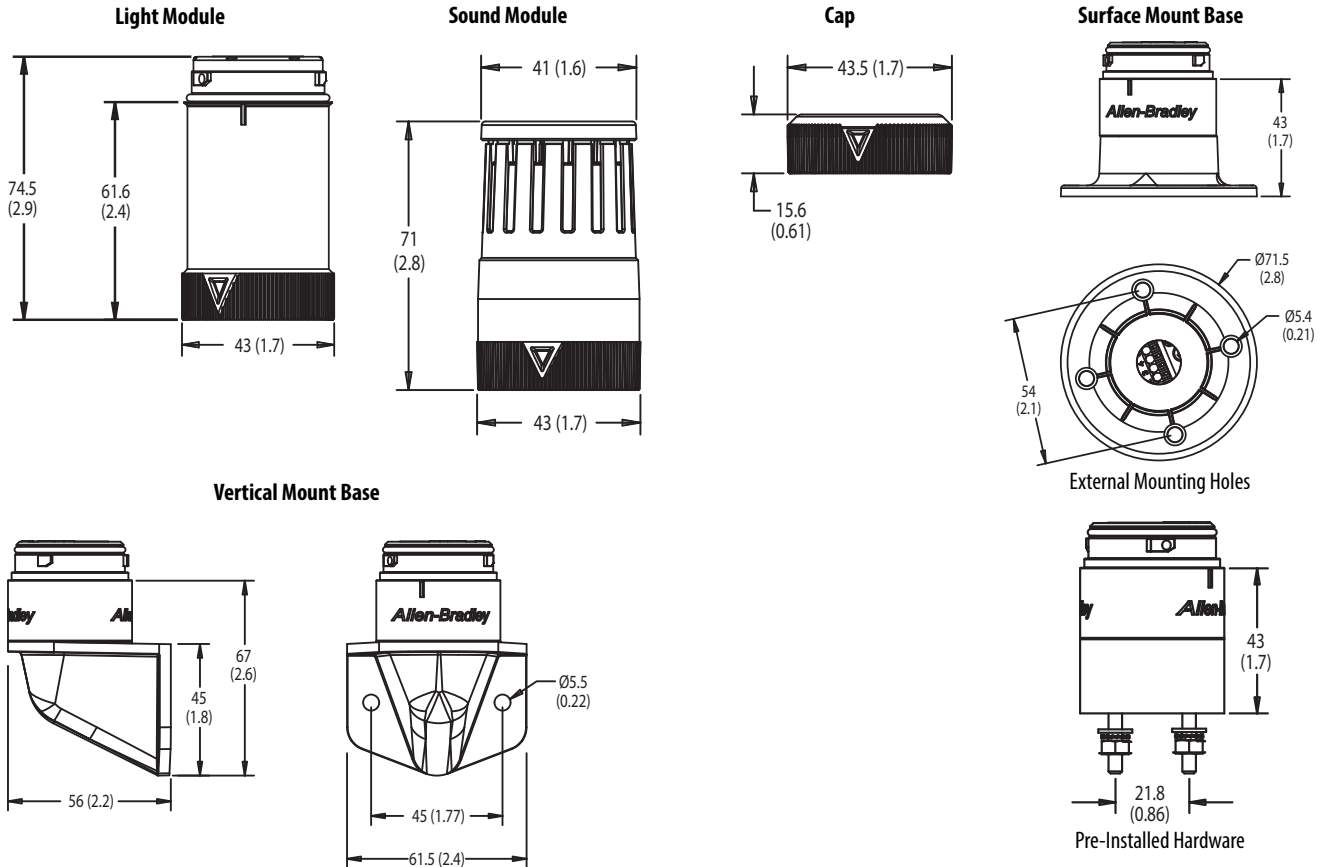

Dimensions in millimeters (inches). Dimensions are not intended to be used for manufacturing purposes.

Quick-Release Base

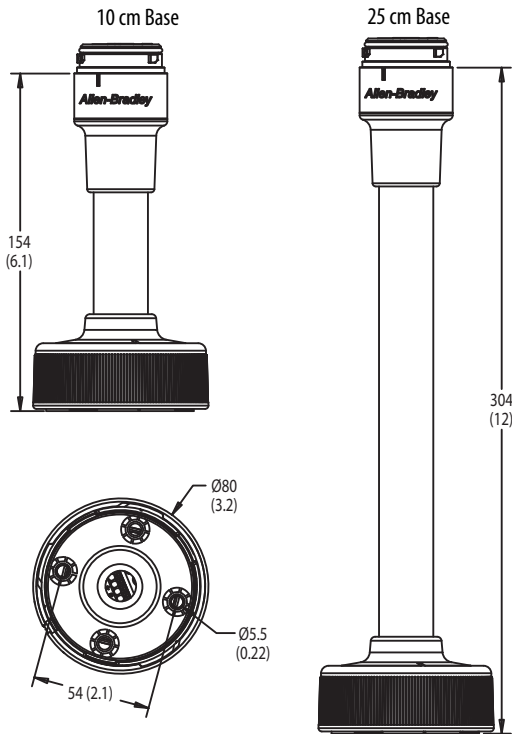

Pole Mount Bases

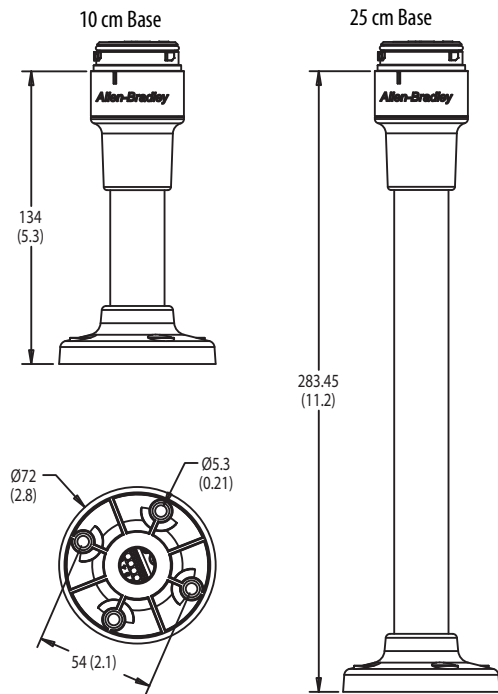

1/2 in. NPT Thread Base

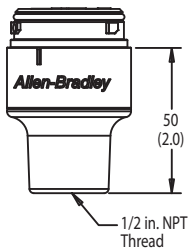

Double-Sided Base

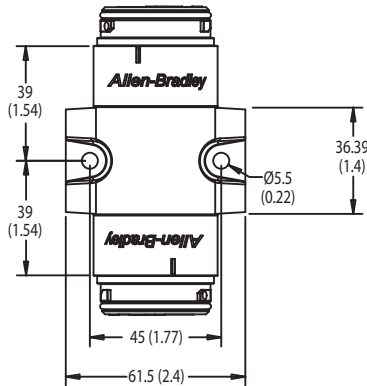

Flange-style Base with M12 Micro Connector (Male)

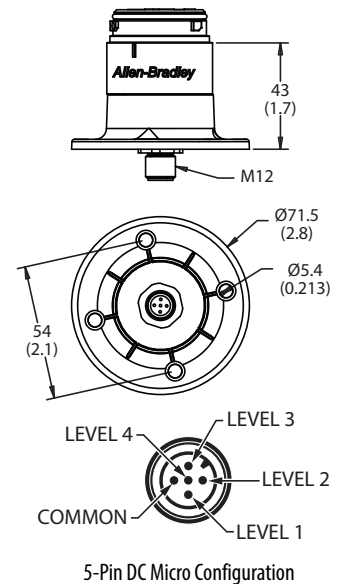

Bulletin 855T— 70 mm Control Tower Stack Lights

Light Modules



Red Flashing Incandescent (Black Housing)

855T -

B	10	FN	4
a	b	c	d

a	
Housing Color	
Code	Description
B	Black
G	Gray

b	
Voltage	
Code	Description
00	0...250V AC/DC (use only with module code XN)
12	12V AC/DC
24	24V AC/DC
10	120V AC
20	240V AC

c	
Light Module Type	
Code	Description
XN	Steady no lamp ⁽¹⁾
DN	Steady incandescent
FN	Flashing incandescent
TL	Steady LED
GL	Flashing LED
RL	Rotating LED, simulated with fixed LEDs ⁽²⁾
BR	Strobe

d	
Lens Color	
Code	Description
3	Green
4	Red
5	Amber
6	Blue
7	Clear
8	Yellow

(1) Use only with Voltage Code 00. Accepts LED module or incandescent lamp.
 (2) Only available with Voltage Codes 10 or 24, and Color Codes 3, 4, or 5.

Combined Light Modules with Piezo Sounder

All single-circuit modules contain a selected light option with a sound device that operates simultaneously. All two-circuit modules contain two circuits enabling separate operation of light or sound. The Piezo-style sound modules can be switched to pulsing or continuous sound with a DIP switch. Additionally, the volume can be adjusted to either low: 92 dB(A) or high: 107 dB(A), via a DIP switch. UL Type 4/4X/13, IP65.



Combination Module

855T – $\frac{B}{a} \frac{10}{b} \frac{DC}{c} \frac{3}{d}$

a	
Housing Color	
Code	Description
B	Black
G	Gray

b	
Voltage	
Code	Description
12	12V AC/DC
24	24V AC/DC
10	120V AC
20	240V AC

c	
Combined Module Type ^{(1) (2)}	
Code	Description
DC	Steady incandescent with sound
DD	Two-circuit steady incandescent with sound
FC	Flashing incandescent with sound
TC	Steady LED with sound
GC	Flashing LED with sound
BC	Strobe with sound

d	
Lens Color	
Code	Description
3	Green
4	Red
5	Amber
6	Blue
7	Clear
8	Yellow

(1) The single-circuit combined light/with sound module uses one circuit in a stack. It can be used with a maximum of four light modules and must be placed in the top position of a stack.
 (2) The two-circuit combined light/with sound module uses two circuits in a stack. It can be used with a maximum of three light modules and must be placed in the top position of a stack.

Transducer-style Sound Modules

- UL Type 12, IP54
- Adjustable volume @ from 85...103 dB @ 1 meter
- Up to 15 tones
- Adjustable frequency and speed tone



Sound Module

855T – $\frac{B}{a} \frac{10}{b} \frac{SA1}{c}$

a	
Housing Color	
Code	Description
B	Black
G	Gray

b	
Voltage	
Code	Description
12	12V AC/DC
24	24V AC/DC
10	120V AC
20	240V AC

c	
Module Type	
Code	Description
SA1	Single-tone sound module with 13 different tones ⁽¹⁾
TA1	Dual-tone sound module with 15 sets of dual-tone combinations ⁽²⁾

(1) This module uses one circuit in a stack. It can be used with maximum of any four light modules and must be placed on top of stack.
 (2) This module uses two circuits in a stack. It can be used with a maximum of any three light modules and must be placed on top of stack.

Piezo-style Sound Modules

- Single or dual circuit versions
- High/low volume selectable via DIP switch

855T – $\frac{G}{a}$ $\frac{24}{b}$ $\frac{TA2}{c}$

a	
Housing Color	
Code	Description
B	Black
G	Gray

b	
Voltage	
Code	Description
12	12V AC/DC
24	24V AC/DC
10	120V AC
20	240V AC

c	
Module Type	
Code	Description
SA2	<ul style="list-style-type: none"> • Single-tone/single-circuit piezo-style module with continuous or pulsing tones modified by a DIP switch • Type 12 • Volume 97 or 85 dB @ 1 m
TA2	<ul style="list-style-type: none"> • Dual-tone/dual-circuit piezo-style module with continuous or pulsing tone modified by energizing one or two circuits of sound modules • Type 12 • Volume 97 or 85 dB @ 1 m
SA3	<ul style="list-style-type: none"> • Single-circuit piezo-style module with continuous or pulsing tones modified by a DIP switch • Type 4/4X/13 • Volume 107 or 92 dB @ 1 m
TA3	<ul style="list-style-type: none"> • Dual-circuit piezo-style module with continuous or pulsing tone modified by energizing one or two circuits of sound modules • Type 4/4X/13 • Volume 107 or 92 dB @ 1 m

Standard and DeviceNet™ Stack Light Bases



855T — DL1 B PM10 C
 a b c c

a	
Network Connection Type	
Code	Description
Blank	No network connection
DM1	DeviceNet micro-connect with 1 m cable ⁽¹⁾
DS2	DeviceNet stranded wire connect with 2 m cable
DL1	DeviceNet mini-connect with 1 m cable

b	
Housing Color	
Code	Description
B	Black
G	Gray

c	
Base Type	
Code	Description
CB	Surface mount—1/2 in. NPT conduit mount
SB	Surface mount — PG16 conduit mount
RB	Surface mount — M20 x 1.5 conduit mount
VM	Vertical mount
TM	25 mm diameter tube mount
PM10	10 cm aluminum pole mount base
PM25	25 cm aluminum pole mount base
PM40	40 cm aluminum pole mount base
SPM10	10 cm stainless steel pole mount ⁽²⁾
SPM25	25 cm stainless steel pole mount ⁽²⁾
SPM40	40 cm stainless steel pole mount ⁽²⁾
SPM60	60 cm stainless steel pole mount ⁽²⁾
SPM80	80 cm stainless steel pole mount ⁽²⁾
MM10	10 cm quick release base
MM25	25 cm quick release base
MM40	40 cm quick release base

d	
Cap Option	
Code	Description
Blank	No cap
C	Cap included

(1) DeviceNet bases DL1, DM1, or DS2 can only be used with 24V AC/DC and they are only available with Base Types CB, SB, VM, TM, PM10, or PM25.
 (2) Stainless Steel tube is powder-coated in black.

Pre-Configured Control Tower Lights, One to Five Modules

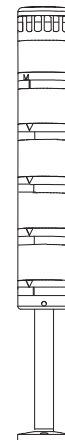
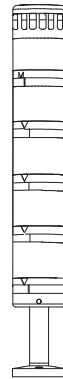
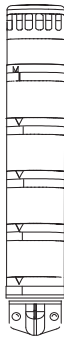
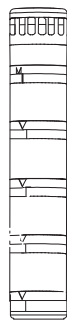

Level 5
Level 4
Level 3
Level 2
Level 1

Surface Mount

Vertical Mount

10 cm Pole Mount

25 cm Pole Mount

855	TS	-	DL1	B	24	Y	4	L	5	B	3	F	7	Y	6
	a		b	c	d	e	f	e	f	e	f	e	f	e	f
						(Level 1, e+f)		(Level 2, e+f)		(Level 3, e+f)		(Level 4, e+f)		(Level 5, e+f)	

a	
Base Type	
Code	Description
TC	Surface mount 1/2 in. NPT conduit
TS	Surface mount PG16 conduit
TV	Vertical mount
TP	10 cm pole mount
TE	25 cm pole mount
TM	25 mm diameter tube mount

b	
Network Options ⁽¹⁾	
Code	Description
Blank	Standard
DL1	DeviceNet mini-connect with 1 m cable
DM1	DeviceNet micro-connect with 1 m cable
DS2	DeviceNet stranded wire connect with 2 m cable

c	
Housing Color	
Code	Description
B	Black
G	Gray

(1) DeviceNet bases DL1, DM1, or DS2 can only be used with 24V AC/DC.

d	
Voltage	
Code	Description
12	12V AC/DC
24	24V AC/DC
10	120V AC
20	240V AC

e	
Module Type	
Code	Description
D	Steady incandescent
F	Flashing incandescent
Y	Steady LED
L	Flashing LED
B	Strobe
T	Steady incandescent with sound ⁽¹⁾
H	Flashing incandescent with sound ⁽¹⁾
J	Dual-circuit steady incandescent with sound
E	Steady LED with sound ⁽¹⁾
G	Flashing LED with sound ⁽¹⁾
Z	Strobe with sound ⁽¹⁾
A	Transducer single-circuit sounder UL Type 12, IP54 ⁽¹⁾
W	Transducer dual-circuit sounder UL Type 12, IP54 ⁽¹⁾
P	Single-circuit piezo alarm
Q	Dual-circuit piezo alarm

f	
Lens Color/Sound	
Code	Description
1	Sound module ⁽²⁾
3	Green
4	Red
5	Amber
6	Blue
7	Clear
8	Yellow

(1) Only one sound module or light module/with sound can be assembled per stack. These modules must always be placed in the top position.

(2) Sound module from Table f can only be selected with single-tone or two-tone module types from Table e.

Specifications

Table 76 - Mechanical

Attribute		Value		
Based on the weight and style of mounting; tower lights are subject to damage from shock and vibration. Listed below are reference guidelines for maximum acceptable conditions.				
		Shock [G]	Vibration [G]	
Standard Bases	Surface Mount Base or 10 cm Aluminum Pole Base	1 Module Stack	150	5
		3 Module Stack	45	1.5
		5 Module Stack	35	0.75
	Vertical Base or 25 cm Aluminum Pole Base	1 Module Stack	95	3.5
		3 Module Stack	30	1.25
		5 Module Stack	20	0.5
DeviceNet Bases	Surface Mount Base or 10 cm Aluminum Pole Base	1 Module Stack	50	5
		3 Module Stack	45	1.5
		5 Module Stack	35	0.75
	Vertical Base or 25 cm Aluminum Pole Base	1 Module Stack	50	3.5
		3 Module Stack	30	1.25
		5 Module Stack	20	0.5
Recommended Wire Sizes		0.5 . . . 2.5 mm ² (22 . . . 14 AWG)		
Recommended Terminal Torque		0.8 N·m (7 lb·in)		

Table 77 - Environmental

Attribute		Value	
Ingress Ratings	Light Modules with Cap and combined Light/Sound Modules	IP65/UL Type 4/4X/13	
	Sound Modules (SA1, SA2, TA1, TA2)	IP54/UL Type 12	
	Sound Modules (SA3, TA3)	IP65/UL Type 4/4X/13	
	Surface, Vertical, Tube Mount, and On-Machine Bases	IP65/UL Type 4/4X/13	
	Pole Mount Bases (Aluminum)	IP65/UL Type 4/13	
	Pole Mount Bases (Stainless Steel)	IP65/UL Type 4/4X/13	
Temperature Ranges	Operating	-25 . . . +70 °C (-13 . . . +158 °F)	
	Storage	-40 . . . +85 °C (-40 . . . +185 °F)	

Table 78 - Materials

Attribute		Value	
Bases, Caps, Lens Covers, Sound Module Housings, Lenses, Lamp Sockets		Polycarbonate	
Rubber Seals and Gaskets		Nitrile rubber	
Pole (for aluminum pole assembly)		Aluminum	
Pole Base Footing (for aluminum pole base)		Polycarbonate	
Pole (for stainless steel assembly)		Powder-coated stainless steel	
Pole Base Footing (for stainless steel pole base)		Zinc	
Insulation Sleeve (for pole insulation)		Polyolefin	
Surface and Vertical Mount Pole Connection Box and Magnetic Mount Housing		Polycarbonate	
Mounting Screw Washers		Polypropylene	
DeviceNet Base Grommet		Neoprene	
DeviceNet Cable Jackets		CPR Chlorinated Polyethylene	
DeviceNet Cable Connectors		Santoprene	

Table 79 - Light Output

Attribute		Value			
		12V AC/DC	24V AC/DC	120V AC	240V AC
Steady Incandescent		0.5 MSCP	2.5 MSCP	3.0 MSCP	0.49 MSCP
Flashing Incandescent		6.3 Lumens	31.4 Lumens	37.7 Lumens	6.2 Lumens
Strobe		3 J per lamp			
Steady/Flashing Socket Mount LED	Red	900...2240 mcd			
	Green	900...1800 mcd			
	Amber	1400...3550 mcd			
	Blue	224...560 mcd			
	White and Yellow	900...1800 mcd			

Table 80 - Operating Voltage

Attribute	Value			
	12V AC/DC	24V AC/DC	120V AC	240V AC
Light modules and sound modules	12V AC/DC (±10%)	24V AC/DC (±10%)	110V AC, 50 Hz (±10%) 120V AC, 60 Hz (±10%)	230V AC, 50 (±10%) 240V AC, 60 (±10%)

Table 81 - Lamp Life Ratings (Design Life) Average Life Under Static, No Vibration, Conditions

Attribute	Value			
	12V AC/DC	24V AC/DC	120V AC	240V AC
Incandescent Modules ^{(1) (2)}	8000 hr	7000 hr	3000 hr	1600 hr
LED Modules	100,000 hr			
Strobe Modules	15,000 hr			
Sound modules	20,000 hr			

(1) First failures at about 35% of average life. Severe vibration can reduce life to 44% of average life.
 (2) Flashing applications can reduce life to 50% of average life.

Table 82 - Current Consumption [mA]

Attribute		Value			
		12V AC/DC	24V AC/DC	120V AC	240V AC
Light only modules	Steady Incandescent	208	271	58	23
	Steady or Flashing LED	42	29	21	20
	Strobe	240	170	50	35
Light modules with sound	Steady Incandescent/with Sound	218	281	78	43
	Flashing Incandescent/with Sound	218	281	78	43
	Steady or Flashing LED/with Sound (Red, Amber, Yellow)	100	62	22.5	20
	Steady or Flashing LED/with Sound (Green, Blue, White)	250	180	70	55
	Strobe/with Sound	250	180	70	55
Transducer Style Sound Modules	Single and Two Circuit Modules	30	65	110V/50 Hz 120V/60 Hz 60 mA	230V/50 Hz 240V/60 Hz 60 mA
Piezo Style Sound Modules	Single and Two Circuit Modules	27	45	43	40
DeviceNet Bases		—	70	—	—

Table 83 - Flashing and Tone Frequency

Attribute	Value
Flashing Frequency (Light Only Modules)	
Flashing Incandescent Modules	12V module approximately 1.5 Hz 24V, 120V, and 240V modules approximately 2 Hz Time ON/Time OFF = 1:1
Flashing LED Modules	Approximately 1.5 Hz; Time On/Time OFF = 1:1
Strobe Modules	Approximately 2 Hz (flash duration 1/50,000 second)
Flashing and Tone Frequency (Light Modules/with Sound Set at Continuous Tone)	
Tone Frequency	Preset at 2400 Hz or 3300 Hz
Flashing Incandescent/ with sound	12V module approximately 1.5 Hz 24V, 120V, and 240V modules approximately 1.6 Hz
Flashing LED/ with sound	Flashing frequency approximately 1.5 Hz
Strobe/with Sound	Flashing frequency approximately 1.4 Hz
Flashing and Tone Pulsing Frequencies (Light Modules/with Sound Set at Pulsing Tone)	
Tone Frequency	Preset at 2400 Hz or 3300 Hz
Steady Incandescent/ with sound	Sound Pulsing Frequency — 1.5 Hz
Flashing Incandescent/ with sound	Flashing and Pulsing Frequency the same for 12V module approximately 1.5 Hz, for 24V, 120V, and 240V modules approximately 1.6 Hz
Steady LED/ with sound	Sound Pulsing Frequency — 1.5 Hz
Flashing LED/ with sound	Flashing and Pulsing Frequency the same at 1.5 Hz
Strobe/with Sound	Flashing and Pulsing Frequency the same at 1.4 Hz

Table 84 - Decibel Rating (Sound Modules) ⁽¹⁾

Attribute	Value
Selectable Tone Sound Module (SA1, TA1)	Maximum volume ranges from 64...103 dB(A) (volume adjustable) Based on tone that is selected for all settings except signal horn, which has a maximum of 80 dB(A)
Piezo Sound Module (SA2, TA2)	High 97 dB/Low 85 dB, selectable via DIP switch
Piezo Sound Module (SA3, TA3)	High 107 dB/Low 95 dB, selectable via DIP switch
Piezo Light Modules and Light Modules/with Sound (set at continuous or pulsing tone)	High 107 dB/Low 95 dB, selectable via DIP switch

(1) All dB(A) ratings determined at a distance of 1 meter from sound module.

Table 85 - Leakage Current Impact

All light modules, sound modules, and light/sound modules can absorb up to 3 mA of leakage current from solid-state outputs without module activation. Some light and light modules with sound may not turn off completely when connected to solid-state outputs that emit leakage current. Listed below are modules that can be affected by an output module emitting a maximum of 3 mA. A dry contact can be used to reduce the effect of leakage current.

12V AC/DC, 24V AC/DC, 120V AC, 240V AC	All light/sound combination modules
--	-------------------------------------

Table 86 - DeviceNet Bases

Attribute	Value
Baud Rate Options	125K, 250K, 500K, Autobaud











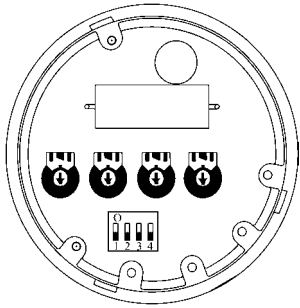















Standards Compliance

- UL 508
- CSA C22.2 No. 14
- EN/IEC 60947-1
- EN/IEC 60947-5-1

Certifications











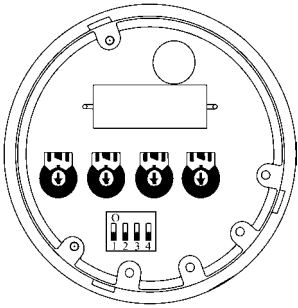



















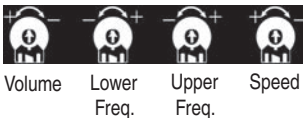











- cULus Listed (File No. E14840, Guides NKCR, NKCR7)
- CE Marked

Transducer Style Single-Circuit Sound Module (SA1)

	DIP Switch Position	Tone Description	Speed [Hz]	Upper Frequency [Hz]	Lower Frequency [Hz]	Volume [dB(A)]	
 <p>Adjustable Sound Settings</p>		Triangle Tone		7...22	1500	500	80...100
		Continuous Tone		—	(1)	500	83...100
		Interrupted Tone		0.5...1.5	(1)	500...1500	83...103
		Changing Tone		0.5...1.5	500...1500	500...1500	83...103
		Saw Tooth Tone Ascending		0.5...1.5	500...1500	500...1500	83...103
		Saw Tooth Tone Descending		0.5...1.5	500...1500	500...1500	83...103
 <p>Rotated View of Sound Settings</p>		Sine-wave Tone		0.5...1.5	500...1500	500...1500	82...102
		DIN-Emergency Signal	DIN 33404	1	1200	500	82...102
		Siren (Non-Repeating)		2...4 s	1500	500	83...103
		Signal Horn Continuous Tone		—	(1)	100...350	64...80
		Three-Tone Gong		2...4 s	660 550 440		76...95
		Two-Tone Gong		2...4 s	550 440		75...93
		Gong		1...3 s	(1)	500...1500	75...93

(1) Set to maximum (+).

Transducer Style Dual-Circuit Sound Module (TA1)

		DIP Switch Position	Tone A		Tone B	
 <p>Adjustable Sound Settings</p>		Triangle Tone		Continuous Tone		
		Continuous Tone		Changing Tone		
		Continuous Tone		Interrupted Tone		
		Interrupted Tone		Three-Tone Gong		
		Interrupted Tone		Siren (Non-Repeating)		
		Changing Tone		DIN-Emergency Signal	DIN 33404	
		Saw Tooth Tone Ascending		Continuous Tone		
 <p>Rotated View of Sound Settings</p>		Saw Tooth Tone Descending		Interrupted Tone		
		Sine-wave Tone		DIN-Emergency Signal	DIN 33404	
		DIN-Emergency Signal	DIN 33404	Three-Tone Gong		
		Siren (Non-Repeating)		Triangle Tone		
		Signal Horn Continuous Tone		Continuous Tone		
		Three-Tone Gong		Sine-wave Tone		
		Two-Tone Gong		Two-Tone Gong (Non-Repeating)		
		Gong		Continuous Tone		

Approximate Dimensions

Dimensions in millimeters (inches). Dimensions are not intended to be used for manufacturing purposes.

Assembled Control Tower Lights — Light Modules Only or Light Modules with Sound Module on top position

If a combined light/sound module is used, add 21.5 mm (0.8 in.) to vertical dimensions.

Surface Mount Base (SB and CB)

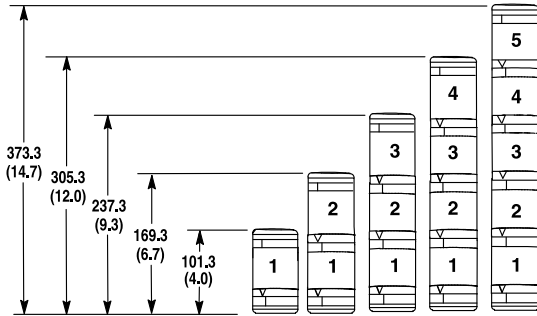

Tube Mount Base (TM)

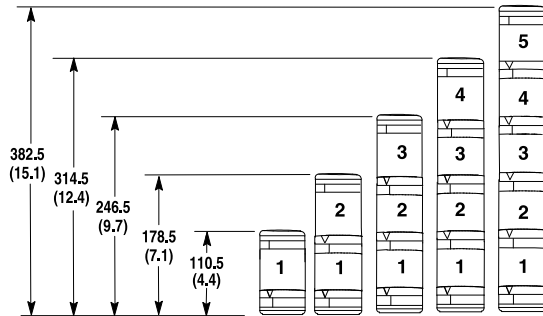

Vertical Mount Base (VM)

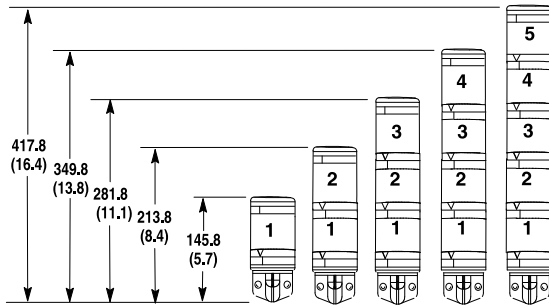

10 cm Pole Mount Base (PM10, SPM25)

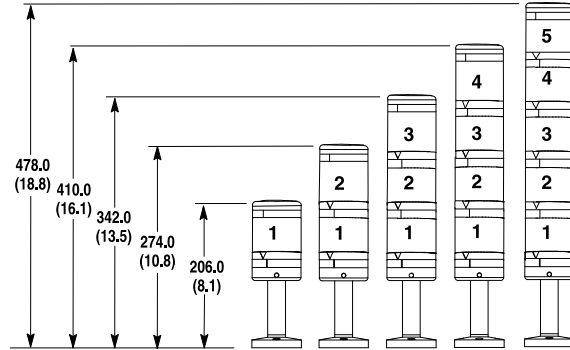

25 cm Pole Mount Base (PM25, SPM25)

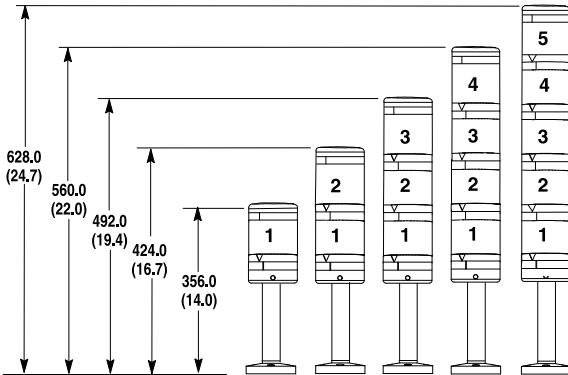

40 cm Pole Mount Base (PM40, SPM40)

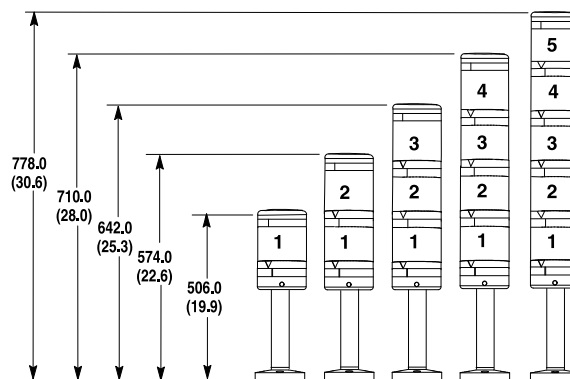

60 cm Pole Mount Base (SPM60)

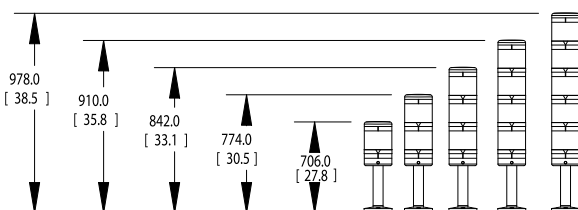

80 cm Pole Mount Base (SPM80)

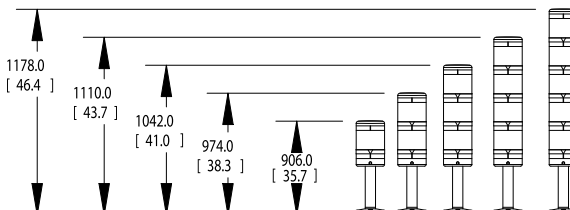

Dimensions in millimeters (inches). Dimensions are not intended to be used for manufacturing purposes.

Component and Accessory Dimensions

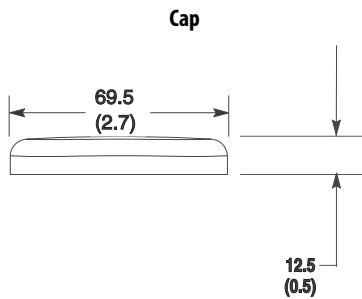
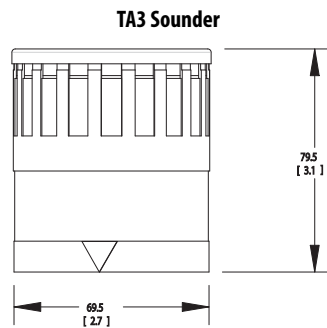
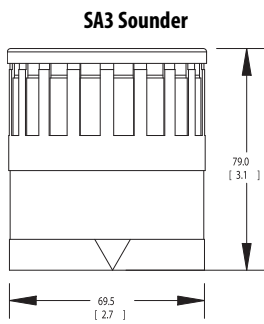
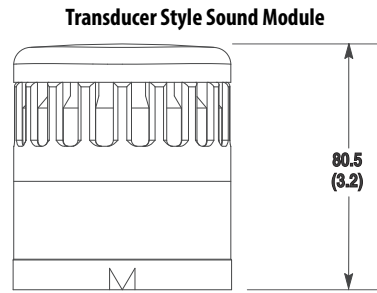
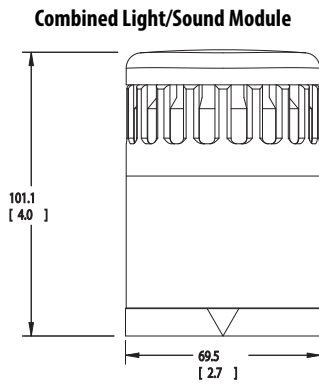
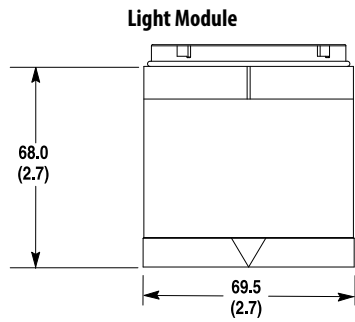

Pole Mount Base, Aluminum or Stainless Steel

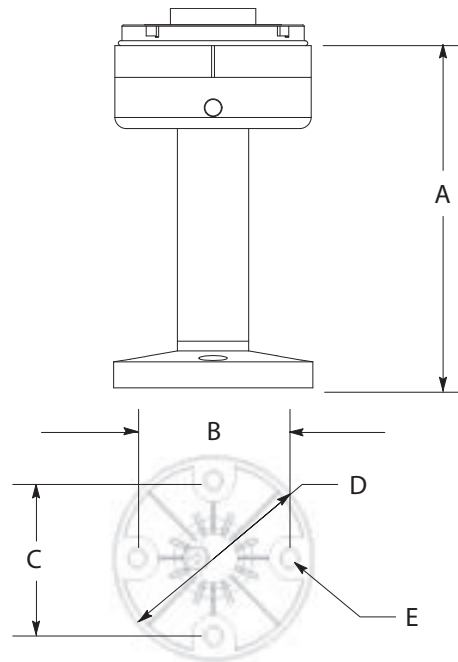

Base Size [cm]	A	B	C	D	E
10	124.5 (4.9)	54.0 (2.1)	54.0 (2.1)	70.0 (2.8)	5.0 (0.2)
25	274.5 (10.8)				
40	424.5 (16.7)				
60	624.5 (24.6)				
80	824.5 (32.5)				

Dimensions in millimeters (inches). Dimensions are not intended to be used for manufacturing purposes.

Pole Mount Gasket

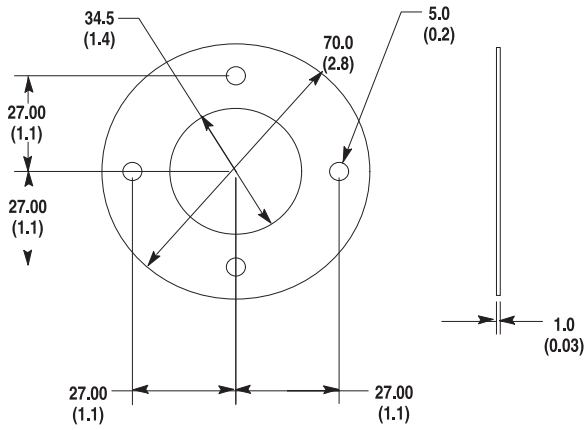

Surface Mount Gasket

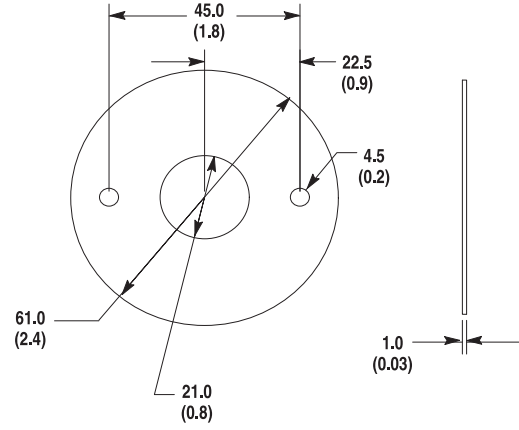

Vertical Mount Gasket

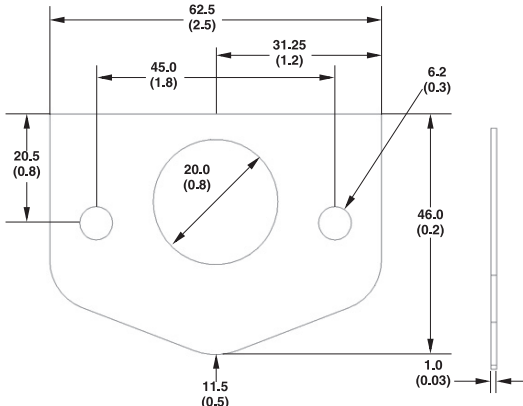

Standard Pole Connection Box

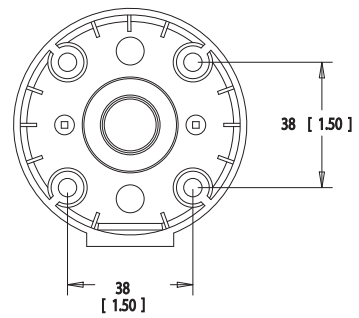

Magnetic Pole Connection Box

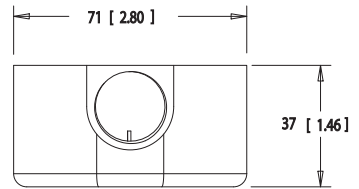
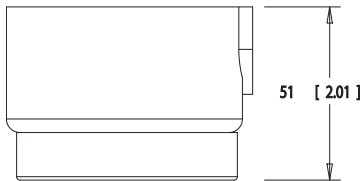

Vertical Mount Base

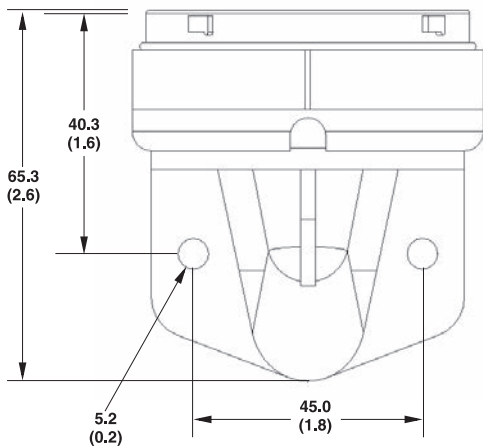

Surface Mount Base 855T-BSB or 855T-BCB

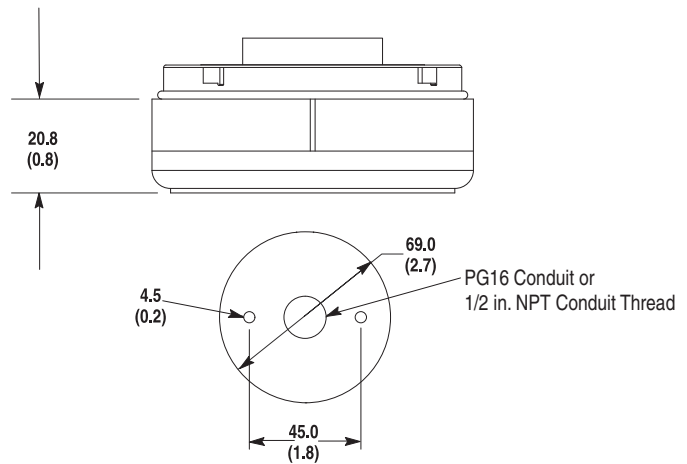

Dimensions in millimeters (inches). Dimensions are not intended to be used for manufacturing purposes.

855E-AVM Vertical Mount Bracket

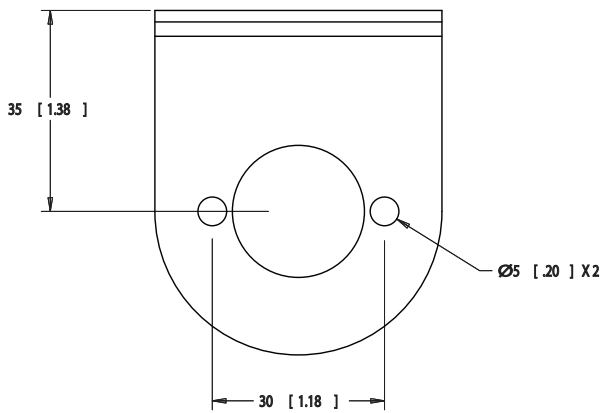
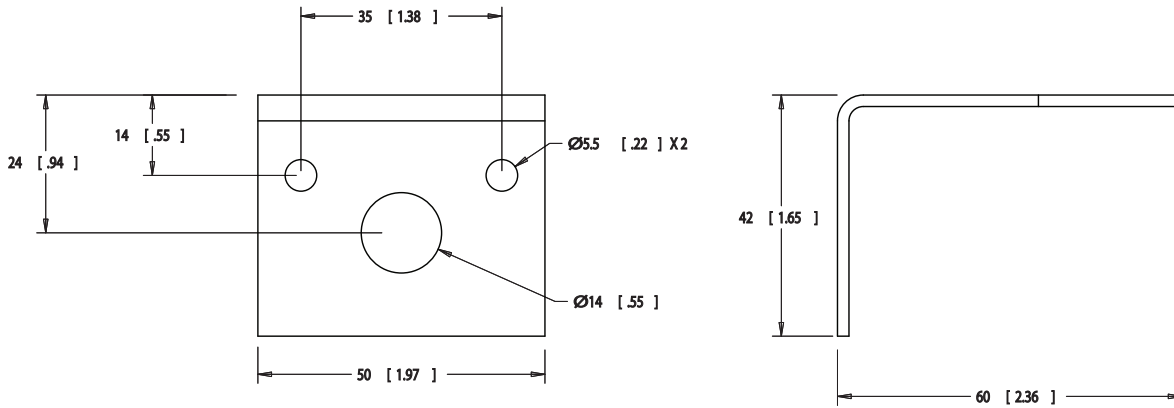

855T-AVM Vertical Mount Bracket

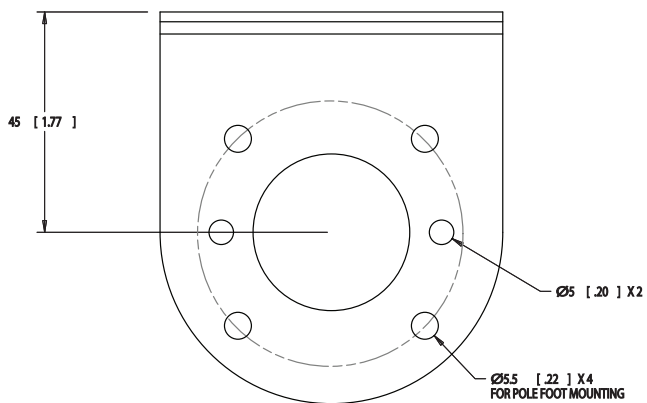
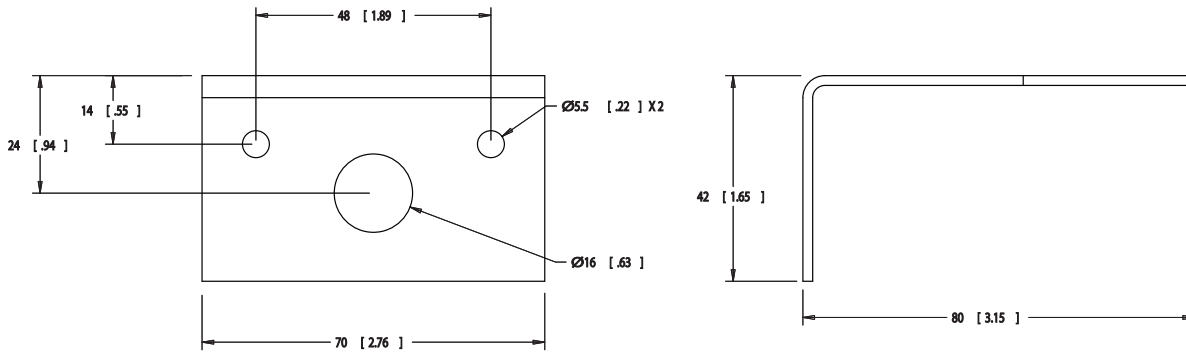

Specifications

Table 87 - Environmental

Attribute		Value
Ingress Ratings	Light/sound modules	IP65/UL Type 4/4X/13
Temperature Ranges	Operating	-25...+50 °C (-13...+122 °F)
	Storage	-25...+85 °C (-13...+185 °F)

Table 88 - Materials

Attribute	Value
Lenses and Base	Polycarbonate (94V-0)
Cover	ABS
Rubber Seals and Gaskets	NBR 70

Table 89 - Operating Voltage

Attribute	Value		
	24V AC/DC	120V AC	240V AC
Light modules and sound modules	24V AC/DC (±10%)	110V AC, 50 Hz (±10%) 120V AC, 60 Hz (±10%)	230V AC, 50 (±10%) 240V AC, 60 (±10%)

Table 90 - Current Consumption [mA]

Attribute	Value		
	24V AC/DC	120V AC	240V AC
Steady or Flashing LED	43 mA per channel, max	33 mA per channel, max	30 mA per channel, max
Piezo sounder	62	24	24

Table 91 - Leakage Current Impact

All light and sound modules can absorb up to 3 mA of leakage current from solid-state outputs without module activation.

Table 92 - Mechanical

Attribute		Value
Design Life Rating (Average life under static, no vibration conditions)	Steady or Flashing LED	30,000...50,000 hr
	Piezo sounder	> 10,000 hr
Frequency	Flashing LED	2 Hz
Decibel Rating	Piezo sounder	90 dB(A) (potentiometer adjustable down to 70 dB(A)) All dB(A) ratings determined at a distance of 1 meter from sound module

Approximate Dimensions

Dimensions in millimeters (inches). Dimensions are not intended to be used for manufacturing purposes.

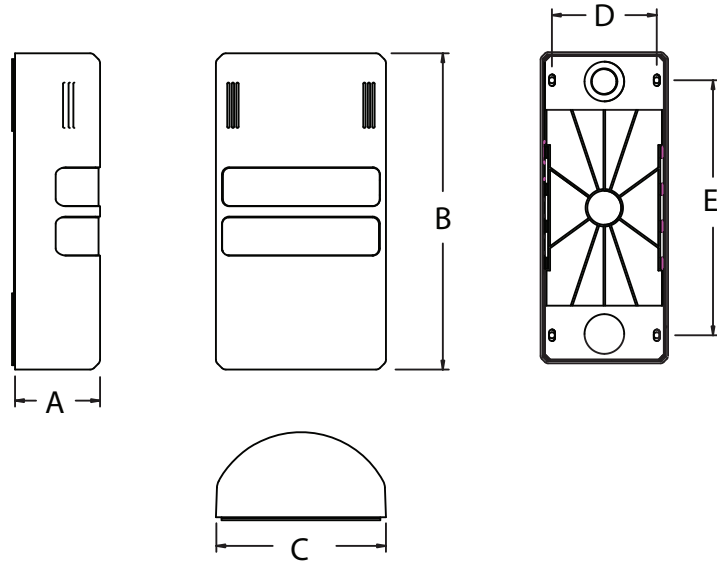

Number of Levels	Dimension A	Dimension B	Dimension C	Dimension D	Dimension E
2	45 (1.77)	167.4 (6.59)	90 (3.54)	74 (2.91)	125 (4.92)
3		193.5 (7.62)			150 (5.91)
4		219.6 (8.65)			180 (7.09)
5		245.7 (9.67)			210 (8.27)

Bulletin 855X — Hazardous Location Horns, Beacons, and Loudspeakers

Alarm Horn Sounders



855XH — $\frac{\text{BN}}{\text{a}}$ $\frac{\text{D30}}{\text{b}}$ $\frac{\text{B}}{\text{c}}$

a	
Product Type	
Code	Description
BN	1/2 in. NPT conduit entrance, black housing

b	
Voltage	
Code	Description
D30	10...30V DC
D48	48V DC
A10	115...120V AC
A20	220...230V AC

c	
Horn Type	
Code	Description
A	110 dB @ 1 m/45 tone/3 stage
B	117 dB @ 1 m/45 tone/3 stage

Xenon Strobe Beacons



855XB — $\frac{\text{BN}}{\text{a}}$ $\frac{\text{A10}}{\text{b}}$ $\frac{\text{B}}{\text{c}}$ $\frac{\text{4}}{\text{d}}$

a	
Product Type	
Code	Description
BN	1/2 in. NPT conduit entrance, black housing

b	
Voltage	
Code	Description
D24	24V DC
D48	48V DC
A10	115...120V AC
A20	220...230V AC

c	
Beacon Type	
Code	Description
A	Xenon strobe - 5 J, 1 Hz
B	Xenon strobe - 10 J, 1 Hz

c	
Lens Color	
Code	Description
3	Green
4	Red
5	Amber
6	Blue
7	Clear
8	Yellow

Combined Horn Sounder and Strobe Beacons



855XC – BN A10 A 4
 a b c d

a	
Product Type	
Code	Description
BN	1/2 in. NPT conduit entrance, black housing

b	
Voltage	
Code	Description
D24	24V DC
D48	48V DC
A10	115...120V AC
A20	220...230V AC

c	
Beacon Type	
Code	Description
A	Xenon strobe - 5 J, 110 dB @ 1 m, 45 tones, 3 stages

c	
Lens Color	
Code	Description
3	Green
4	Red
5	Amber
6	Blue
7	Clear
8	Yellow

Public Address Loudspeakers

855XL – BN 70 A
 a b c

a	
Product Type	
Code	Description
BN	1/2 in. NPT conduit entrance, black housing

b	
Voltage	
Code	Description
70	70V line (tappings: 15 W, 7.5 W, 3 W, 1 W)
100	100V line (tappings: 15 W, 7.5 W, 3 W, 1 W)
8R	8 Ω
16R	16 Ω

c	
Beacon Type	
Code	Description
A	15 W RMS

Specifications

Table 93 - Mechanical

Device	855XH Horn	855XB Beacon	855XC Horn-Beacon Combination	855XL Public Address Loudspeaker
Shock	30 G Peak			
Vibration	2 G Peak			

Table 94 - Environmental

Device	855XH Horn	855XB Beacon	855XC Horn-Beacon Combination	855XL Public Address Loudspeaker
Ingress Ratings	IP66/67 and UL Type 4/4X13, IP 66/67			
Temperature Ranges	Operating	-4...+131 °F (-20...+55 °C)		
	Storage	-4...+167 °F (-20...+75 °C)		

Table 95 - Materials

Device	855XH Horn	855XB Beacon	855XC Horn-Beacon Combination	855XL Public Address Loudspeaker
Covers	PPS glass-filled plastic			
Bases	PPS glass-filled plastic			
Mounting Bracket	Stainless Steel 304 (A2)			
Gaskets	Viton			
Beacon Lens	Glass			
Beacon Housing	PPS glass-filled plastic			

Table 96 - Performance Ratings

Device	855XH Horn	855XB Beacon	855XC Horn-Beacon Combination	855XL Public Address Loudspeaker	
Sound Output	dB @ 1 meter	110 or 117	—	110	—
Xenon Lamp Rating	[J]	—	5 or 10	5	—
Flashing Frequency	[Hz]	—	1	1	—

Table 97 - Voltage and Current Consumption

Device	Input Voltage	12V AC/DC	24V AC/DC	48V DC (I/P Volts, Max)	10V AC, 50/60 Hz	230V AC, 50/60 Hz
855XH Horn 110 dB @ 1 m	DC Units: 10...30V or 48V	—	284 mA (30V)	146 mA (58V)	—	—
	AC Units: 120V or 230V, 50/60 Hz	—	—	—	104 mA (132V)	54 mA (253V)
855XH Horn 117 dB @ 1 m	DC Units: 10...30V or 48V	—	280 mA (30V)	215 mA (58V)	—	—
	AC Units: 120V or 230V, 50/60 Hz	—	—	—	142 mA (132V)	76 mA (253V)
855XB Beacon, 5 J	DC Units: 12, 24, or 48V	520 mA (15V)	275 mA (30V)	145 mA (58V)	—	—
	AC Units: 120V or 230V, 50/60 Hz	—	—	—	80 mA (132V)	30 mA (253V)
855XB Beacon, 10 J	DC Units: 24 or 48V	—	560 mA (30V)	260 mA (58V)	—	—
	AC Units: 120V or 230V, 50/60 Hz	—	—	—	185 mA (132V)	107 mA (253V)
855XC Combined Horn (110 dB @ 1 m) and Strobe Beacon (5 J)	Horn Section DC Units: 24V or 48V	—	284 mA (30V)	146 mA (58V)	—	—
	Horn Section AC Units: 120V or 230V, 50/60 Hz	—	—	—	104 mA (132V)	54 mA (253V)
	Beacon Section DC Units: 24V or 48V	—	275 mA (30V)	145 mA (58V)	—	—
	Beacon Section AC Units: 120V or 230V, 50/60 Hz	—	—	—	80 mA (132V)	30 mA (253V)

Table 98 - Operating Ratings

Device	Impedance	Input	Wattage	I/P Volts, Max
855XL PA Loudspeaker ⁽¹⁾	8 Ω	8 Ω	15 W	10.095V
	16 Ω	16 Ω	15 W	15.49V
	100V Line	100V Line	15 W	100V
	70V Line	70V Line	15 W	70V

(1) Power Amplifier Selection: It is important that loudspeakers are connected to power amplifiers that have outputs compatible to the type of loudspeaker being used. Loudspeakers with a 70V or 100V line-matching transformer fitted must be connected to a power amplifier with a 70V or 100V line output. Low impedance 8 Ω or 16 Ω loudspeakers must be connected to amplifiers with a suitable low-impedance output.

Table 99 - Temperature Ratings

Device	Hazardous Location	Code (Operating Temperature, Max) @ 55 °C Ambient	Code (Operating Temperature, Max) @ 40 °C Ambient
855XB- 5 J Beacon	Class I, Division 2, Groups A, B, C, D	T2D (215 °C)	T3 (200 °C)
	Class II, Division 2, Groups F and G	T5 (100 °C)	T6 (85 °C)
	Class III, Divisions 1 and 2	T5 (100 °C)	T6 (85 °C)
855XB- 10 J Beacon	Class I, Division 2, Groups A, B, C, D	T2A (280 °C)	—
	Class II, Division 2, Groups F and G	T4A (120 °C)	T5 (100 °C)
	Class III, Divisions 1 and 2	T4A (120 °C)	T5 (100 °C)
855XH- 110 dB Sounder	Class I, Division 2, Groups A, B, C, D	T3C (160 °C)	T4 (135 °C)
	Class II, Division 2, Groups F and G	T6 (85 °C)	—
	Class III, Divisions 1 and 2	T6 (85 °C)	—
855XH- 117 dB Sounder	Class I, Division 2, Groups A, B, C, D	T3C (160 °C)	T4 (135 °C)
	Class II, Division 2, Groups F and G	T6 (85 °C)	—
	Class III, Divisions 1 and 2	T6 (85 °C)	—
855XC- Sound/Strobe Combination	Class I, Division 2, Groups A, B, C, D	T2D (215 °C)	T3 (200 °C)
	Class II, Division 2, Groups F and G	T5 (100 °C)	T6 (85 °C)
	Class III, Divisions 1 and 2	T5 (100 °C)	T6 (85 °C)
855XL- Loudspeaker	Class I, Division 2, Groups A, B, C, D	T4 (135 °C)	T4A (120 °C)
	Class II, Division 2, Groups F and G	T6 (85 °C)	—
	Class III, Divisions 1 and 2	T6 (85 °C)	—

Standards Compliance

- UL 508
- UL 1604
- CSA C22.2 No. 14
- CSA C22.2 No. 213
- EN/IEC 60947-1
- EN/IEC 60947-5-1

Certifications

- CE Marked
- cULus Listed (File No. E305538 for Beacons and File No. E305533 for Horns and Combination units) for Class I, Division 2, Groups A, B, C, and D; Class II, Division 2, Groups F & G, and Class III, Division 1 & 2

Tone Selection Table for 855XH and 855XC Units

Stage 1	Frequency Description	Switch						Stage 2	Stage 3
		1	2	3	4	5	6		
1	340 Hz, Continuous	0	0	0	0	0	0	Tone 2	Tone 5
2	800/1000 Hz @ 0.25 s, Alternating	1	0	0	0	0	0	Tone 17	Tone 5
3	500/1200 Hz @ 0.3 Hz s, Slow Whoop	0	1	0	0	0	0	Tone 2	Tone 5
4	800/1000 Hz @ 1 Hz, Sweeping	1	1	0	0	0	0	Tone 6	Tone 5
5	2400 Hz, Continuous	0	0	1	0	0	0	Tone 3	Tone 20
6	2400/2900 Hz @ 7 Hz, Sweeping	1	0	1	0	0	0	Tone 7	Tone 5
7	2400/2900 Hz @ 1 Hz, Sweeping	0	1	1	0	0	0	Tone 10	Tone 5
8	500/1200/500 Hz @ 0.3 Hz, Sweeping	1	1	1	0	0	0	Tone 2	Tone 5
9	1200/500 Hz @ 1 Hz, - DIN PFEER P.T.A.P.	0	0	0	1	0	0	Tone 15	Tone 2
10	2400/2900 Hz @ 2 Hz, Alternating	1	0	0	1	0	0	Tone 7	Tone 5
11	1000 Hz @ 1 Hz, Intermittent	0	1	0	1	0	0	Tone 2	Tone 5
12	800/1000 Hz @ 0.875 Hz, Alternating	1	1	0	1	0	0	Tone 4	Tone 5
13	2400 Hz @ 1 Hz, Intermittent	0	0	1	1	0	0	Tone 15	Tone 5
14	800 Hz, 0.25 s ON, 1 s OFF, Intermittent	1	0	1	1	0	0	Tone 4	Tone 5
15	800 Hz, Continuous	0	1	1	1	0	0	Tone 18	Tone 5
16	660 Hz, 150 ms ON, 150 ms OFF, Intermittent	1	1	1	1	0	0	Tone 2	Tone 27
17	544 Hz (100 ms)/440 Hz (400 ms), - NF S 32-001	0	0	0	0	1	0	Tone 2	Tone 5
18	660 Hz, 1.8 s ON, 1.8 s OFF, Intermittent	1	0	0	0	1	0	Tone 2	Tone 5
19	1.4 kHz...1.6 kHz 1 s, 1.6 kHz...1.4 kHz 0.5 s, - NFC48-265	0	1	0	0	1	0	Tone 2	Tone 5
20	660 Hz, Continuous	1	1	0	0	1	0	Tone 2	Tone 5
21	554 Hz/440 Hz @ 1 Hz, Alternating	0	0	1	0	1	0	Tone 2	Tone 5
22	544 Hz @ 0.875 s, Intermittent	1	0	1	0	1	0	Tone 2	Tone 5
23	800 Hz @ 2 Hz, Intermittent	0	1	1	0	1	0	Tone 6	Tone 5
24	800/1000 Hz @ 50 Hz, Sweeping	1	1	1	0	1	0	Tone 29	Tone 5
25	2400/2900 Hz @ 50 Hz, Sweeping	0	0	0	1	1	0	Tone 29	Tone 5
26	Bell	1	0	0	1	1	0	Tone 2	Tone 15
27	554 Hz, Continuous	0	1	0	1	1	0	Tone 26	Tone 5
28	440 Hz, Continuous	1	1	0	1	1	0	Tone 2	Tone 5
29	800/1000 Hz @ 7 Hz, Sweeping	0	0	1	1	1	0	Tone 7	Tone 5
30	300 Hz, Continuous	1	0	1	1	1	0	Tone 2	Tone 5
31	660/1200 Hz @ 1 Hz, Sweeping	0	1	1	1	1	0	Tone 26	Tone 5
32	Two-tone chime	1	1	1	1	1	0	Tone 26	Tone 15
33	745 Hz @ 1 Hz, Intermittent	0	0	0	0	0	1	Tone 2	Tone 5
34	1000 & 2000 Hz @ 0.5 s, Alternating - Singapore	1	0	0	0	0	1	Tone 38	Tone 45
35	420 Hz @ 0.625 s, Australian Alert	0	1	0	0	0	1	Tone 36	Tone 5
36	500...1200 Hz 3.75 s/0.25 s, Australian Evac.	1	1	0	0	0	1	Tone 35	Tone 5
37	1000 Hz, Continuous, - PFEER Toxic Gas	0	0	1	0	0	1	Tone 9	Tone 45
38	2000 Hz, Continuous	1	0	1	0	0	1	Tone 34	Tone 45
39	800 Hz 0.25 s ON, 1 sec OFF, Intermittent	0	1	1	0	0	1	Tone 23	Tone 17
40	544 Hz (100 ms)/440 Hz (400 ms), - NF S 32-001	1	1	1	0	0	1	Tone 31	Tone 27
41	Motor Siren - slow rise to 1200 Hz	0	0	0	1	0	1	Tone 2	Tone 5
42	Motor Siren - slow rise to 800 Hz	1	0	0	1	0	1	Tone 2	Tone 5
43	1200 Hz, Continuous	0	1	0	1	0	1	Tone 2	Tone 5
44	Motor Siren - slow rise to 2400 Hz	1	1	0	1	0	1	Tone 2	Tone 5
45	1 kHz 1 s ON, 1 s OFF, Intermittent, - PFEER Gen. Alarm	0	0	1	1	0	1	Tone 38	Tone 34

Approximate Dimensions

Dimensions in millimeters (inches). Dimensions are not intended to be used for manufacturing purposes.

Horns

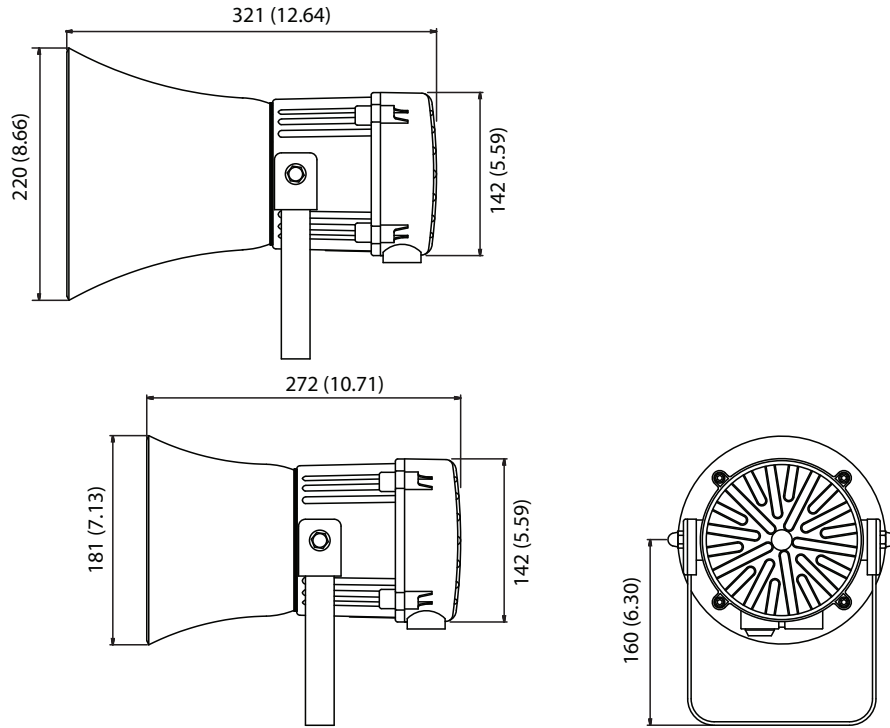

Beacons

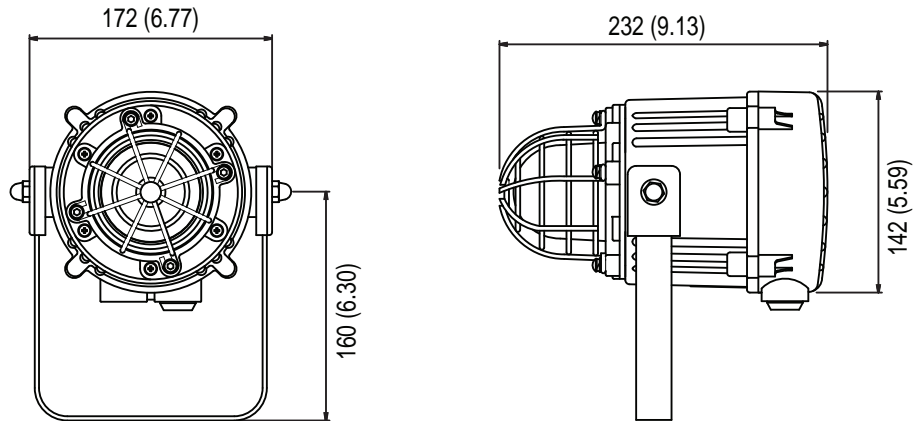

Horn and Beacon Combinations

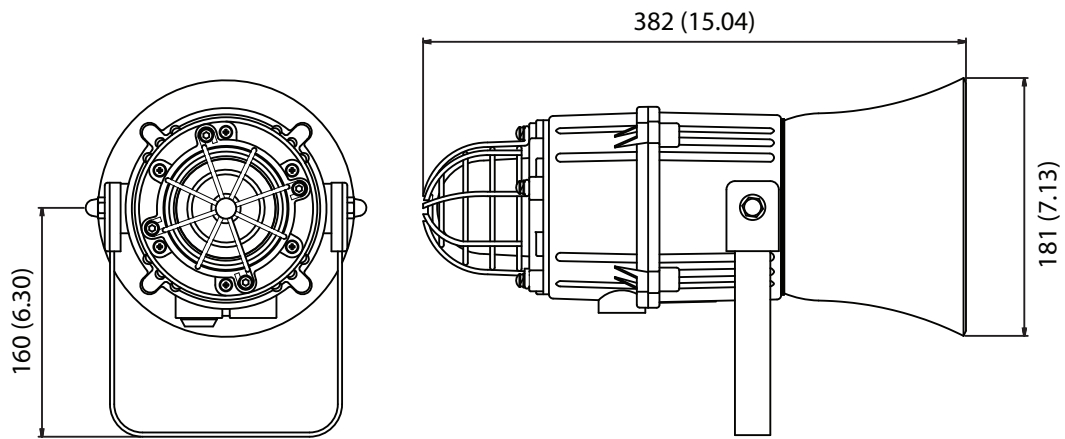

Public Address Loudspeakers

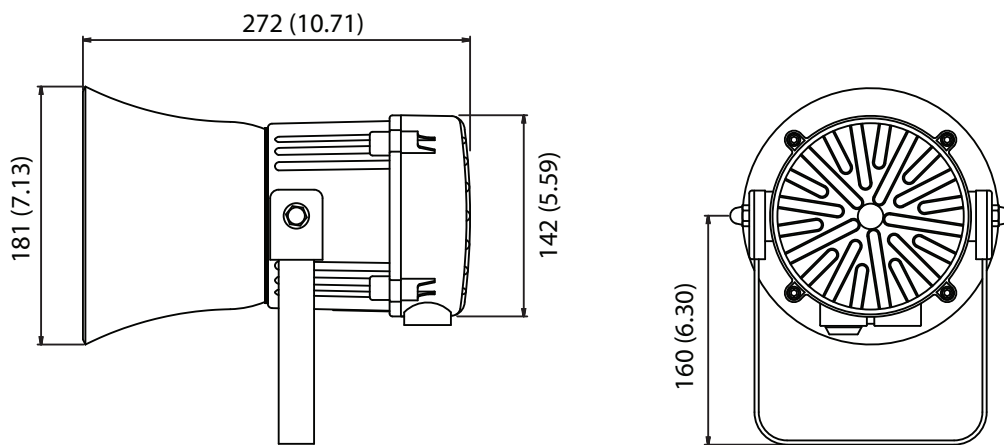

Rockwell Automation Support

Use the following resources to access support information.

Technical Support Center	Knowledgebase Articles, How-to Videos, FAQs, Chat, User Forums, and Product Notification Updates.	www.rockwellautomation.com/knowledgebase
Local Technical Support Phone Numbers	Locate the phone number for your country.	www.rockwellautomation.com/global/support/get-support-now.page
Direct Dial Codes	Find the Direct Dial Code for your product. Use the code to route your call directly to a technical support engineer.	www.rockwellautomation.com/global/support/direct-dial.page
Literature Library	Installation Instructions, Manuals, Brochures, and Technical Data.	www.rockwellautomation.com/literature
Product Compatibility and Download Center (PCDC)	Get help determining how products interact, check features and capabilities, and find associated firmware.	www.rockwellautomation.com/global/support/pcdc.page

Documentation Feedback

Your comments will help us serve your documentation needs better. If you have any suggestions on how to improve this document, complete the How Are We Doing? form at http://literature.rockwellautomation.com/idc/groups/literature/documents/du/ra-du002_-en-e.pdf.

Rockwell Automation maintains current product environmental information on its website at <http://www.rockwellautomation.com/rockwellautomation/about-us/sustainability-ethics/product-environmental-compliance.page>.

Allen-Bradley, Control Tower, LISTEN. THINK. SOLVE., Rockwell Automation, and Rockwell Software are trademarks of Rockwell Automation, Inc. Trademarks not belonging to Rockwell Automation are property of their respective companies.

Rockwell Otomasyon Ticaret A.Ş., Kar Plaza İş Merkezi E Blok Kat:6 34752 İçerenköy, İstanbul, Tel: +90 (216) 5698400

www.rockwellautomation.com

Power, Control and Information Solutions Headquarters

Americas: Rockwell Automation, 1201 South Second Street, Milwaukee, WI 53204-2496 USA, Tel: (1) 414.382.2000, Fax: (1) 414.382.4444
Europe/Middle East/Africa: Rockwell Automation NV, Pegasus Park, De Kleetlaan 12a, 1831 Diegem, Belgium, Tel: (32) 2 663 0600, Fax: (32) 2 663 0640
Asia Pacific: Rockwell Automation, Level 14, Core F, Cyberport 3, 100 Cyberport Road, Hong Kong, Tel: (852) 2887 4788, Fax: (852) 2508 1846

Publication 855-TD001B-EN-P - February 2016

Supersedes Publication 855-TD001A-EN-P - September 2014

Copyright © 2016 Rockwell Automation, Inc. All rights reserved. Printed in the U.S.A.