

Carlton®

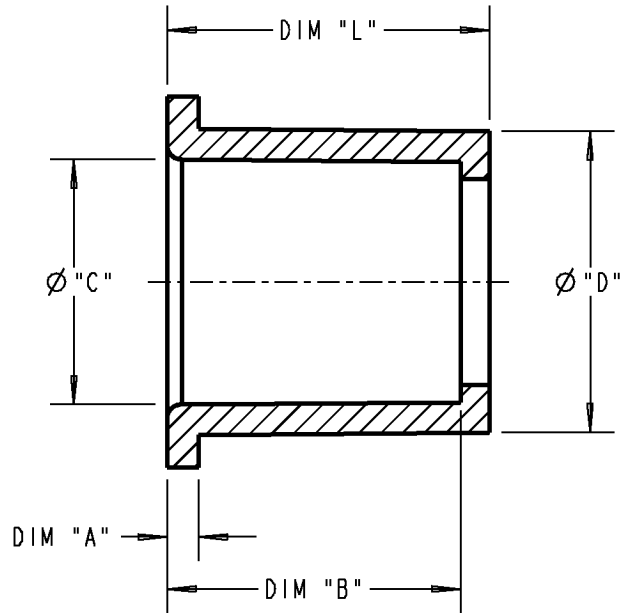
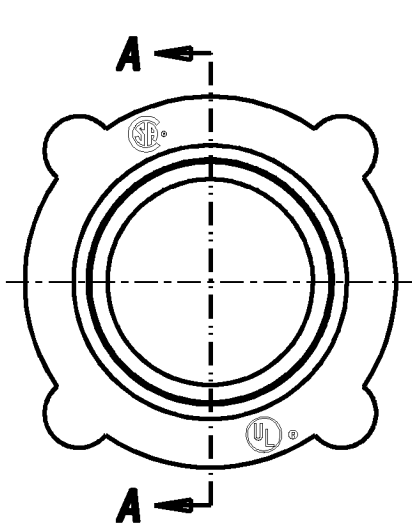

SECTION **A-A**

PART NO.	SIZE	DIM "L"	DIM "A"	DIM "B"	Ø "C"	Ø "D"
E950ED E950EDCL E950ED-CTN E950EDL	3/4 X 1/2	1.12 [28.4]	.10 [2.5]	1.02 25.4]	.86 [21.8]	1.04 [26.4]
E950FD-CAR E950FDL	1 X 1/2	1.34 [34.0]	.13 [3.3]	.87 [22.1]	.85 [21.6]	1.31 [33.3]
E950FE E950FECL E950FE-CTN E950FEL	1 X 3/4	1.25 [31.7]	.11 [2.8]	1.05 [26.7]	1.06 [26.9]	1.31 [33.3]
E950GF E950GFCL E950GF-CTN E950GFL	1-1/4 X 1	1.45 [36.8]	.13 [3.3]	1.13 [28.7]	1.33 [33.8]	1.67 [42.4]
E950HG-CAR E950HGR E950HGRL E950HGRL	1-1/2 X 1-1/4	1.59 [40.4]	.13 [3.3]	1.27 [32.3]	1.68 [42.7]	1.89 [48.0]
E950JH-CAR E950JHR E950JHRCL E950JHRL	2 X 1-1/2	1.75 [44.5]	.13 [3.3]	1.39 [35.3]	1.92 [48.8]	2.37 [60.2]
E950KJ-CAR	2-1/2 X 2	2.13 [54.1]	.36 [9.1]	1.53 [38.8]	2.39 [60.7]	2.78 [70.6]

GENERAL NOTES

1. ALL DIMENSIONS ARE FOR REFERENCE ONLY.
2. DIMENSIONS IN BRACKETS [] ARE IN METRIC UNITS.

REVISIONS

*** SEE ERN (****) FOR APPROVAL SIGNATURES & RELEASE DATE.
PROJECT NO: ****

Thomas & Betts
www.tnb.com

DESCRIPTION:

REDUCER BUSHINGS

ORIGINAL PROJECT NO / (ERN NO)

/ ()

SHEET NO:

1 OF 3

REV. NO:

E

DRAWING NO:

WSD-AC03010

Carlton®

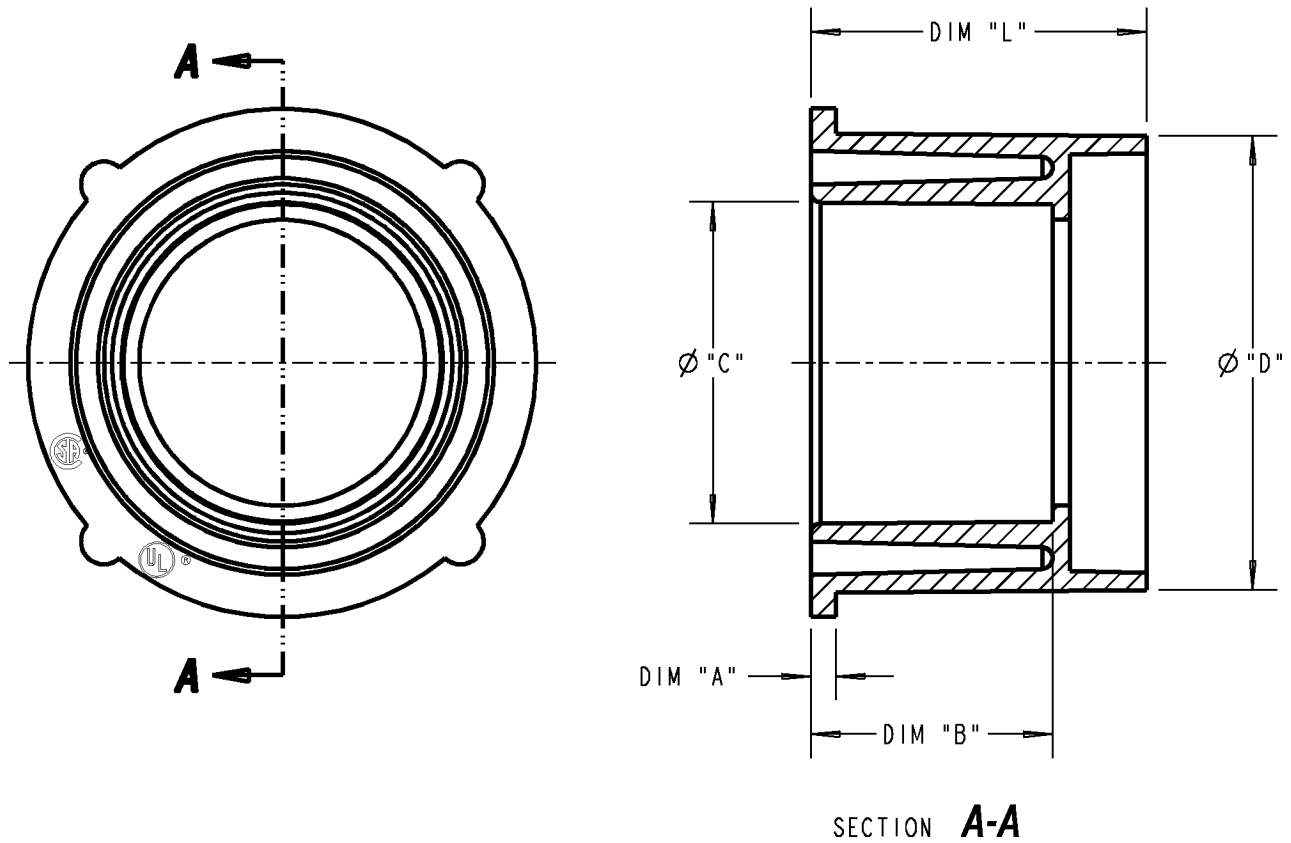

PART NO.	SIZE	DIM "L"	DIM "A"	DIM "B"	Ø "C"	Ø "D"
E950GE-CAR	1-1/4 X 3/4	1.46 [37.1]	.13 [3.3]	1.00 [25.4]	1.06 [26.9]	1.67 [42.4]
E950HF-CAR	1-1/2 x 1	1.59 [40.4]	.13 [3.3]	1.13 [28.7]	1.33 [33.8]	1.89 [48.0]
E950JG-CAR	2 X 1-1/4	1.75 [44.5]	.13 [3.3]	1.26 [32.0]	1.68 [42.7]	2.37 [60.2]

GENERAL NOTES

- ALL DIMENSIONS ARE FOR REFERENCE ONLY.
- DIMENSIONS IN BRACKETS [] ARE IN METRIC UNITS.

REVISIONS

*** SEE ERN (****) FOR APPROVAL SIGNATURES & RELEASE DATE.
PROJECT NO: ****

Thomas & Betts
www.tnb.com

DESCRIPTION:

REDUCER BUSHINGS

ORIGINAL PROJECT NO / (ERN NO)

/ ()

SHEET NO:

2 OF 3

REV. NO:

E

DRAWING NO:

WSD-AC03010

Carlton®

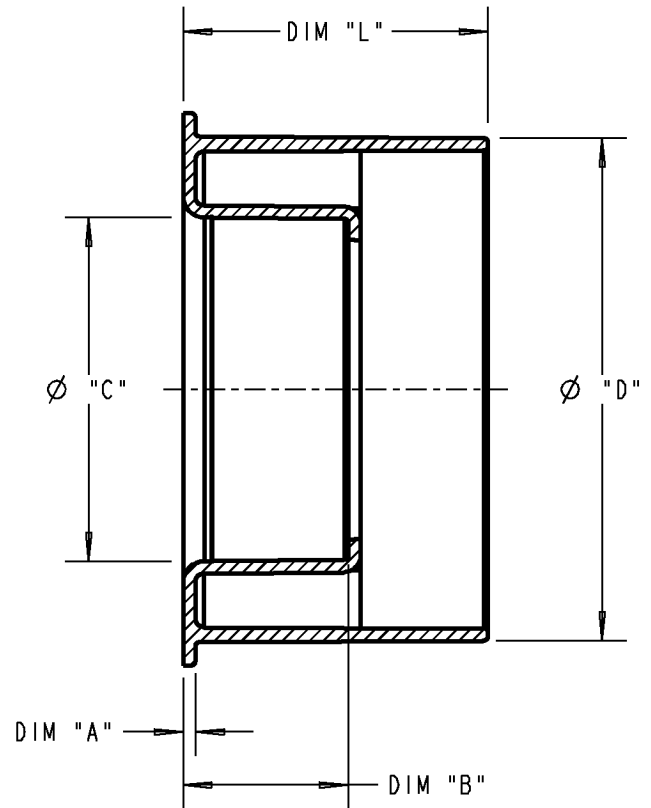
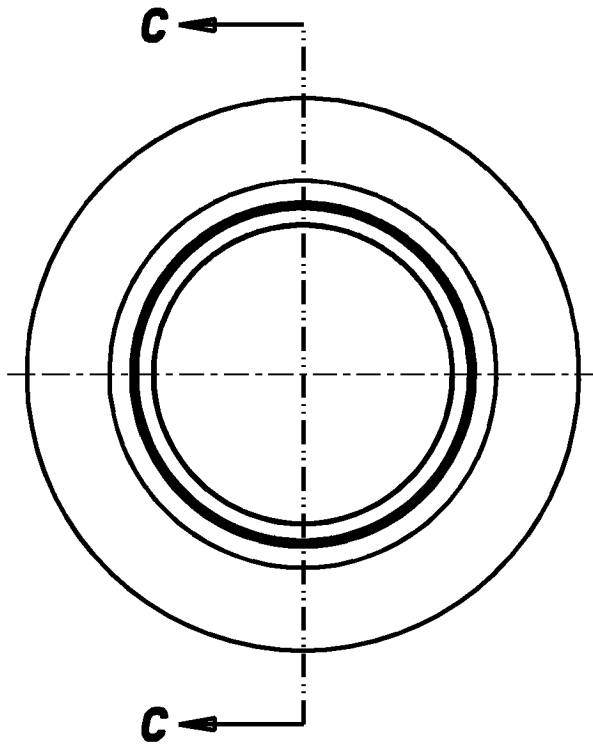

SECTION **C-C**
SCALE 0.750

PART NO.	SIZE	DIM "L"	DIM "A"	DIM "B"	Ø "C"	Ø "D"
E950LJ-CAR E950LJL	3 X 2	2.12 [53.8]	.09 [2.3]	1.15 [29.2]	2.39 [60.7]	3.50 [88.9]
E950LK	3 X 2-1/2	2.12 [53.8]	.06 [1.5]	1.50 [38.1]	2.89 [73.4]	3.50 [88.9]
E950NL	4 X 3	2.73 [69.3]	.34 [8.6]	1.97 [50.0]	3.50 [88.9]	4.50 [114.3]

GENERAL NOTES

1. ALL DIMENSIONS ARE FOR REFERENCE ONLY.
2. DIMENSIONS IN BRACKETS [] ARE IN METRIC UNITS.

REVISIONS

*** SEE ERN (****) FOR APPROVAL SIGNATURES & RELEASE DATE.
PROJECT NO: ****

Thomas & Betts
www.tnb.com

DESCRIPTION: **REDUCER BUSHINGS**

ORIGINAL PROJECT NO / (ERN NO)
/ ()

SHEET NO:
3 OF 3

REV. NO:
E

DRAWING NO:
WSD-AC03010