

Wide Span Cable Tray

perforated, with continuous perforated and beaded side profiles

WRL 150.200

EAN Code: 4013339313204
Smallest packaging unit: 6 m
quantity unit: m M

the photorealistic images are to be considered as reference images

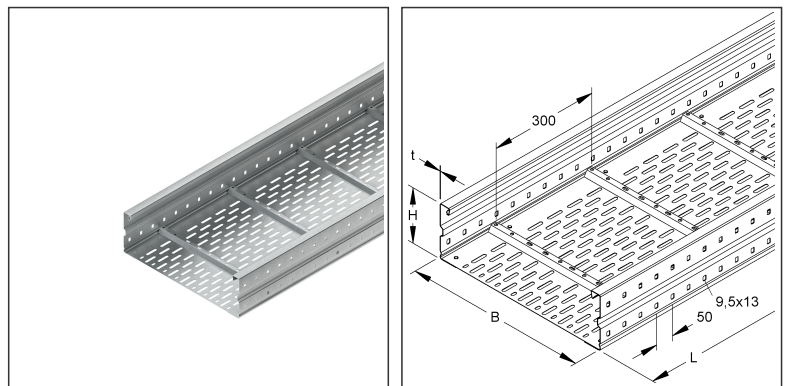

Article Description

Wide span cable tray, 150x200x6000 mm, t=1,5 mm, perforated, steel, pre-galvanised according to DIN EN 10346

Additional Price Information

Article group	N13
quantity unit	m

Weight

Weight per quantity unit	7,301 kg/ m
Weight in kg per 100	730 kg/ 100m

Technical Datasheet

Long Span Cable Tray

WRL 150.200

the photorealistic images are to be considered as reference images

Physical Article Dimensions

Height	150.00 mm
Width	200.00 mm
Depth/length	6000 mm

Load Specifications

Load diagram: q = evenly distributed cable load (tested acc. to DIN EN IEC 61537)

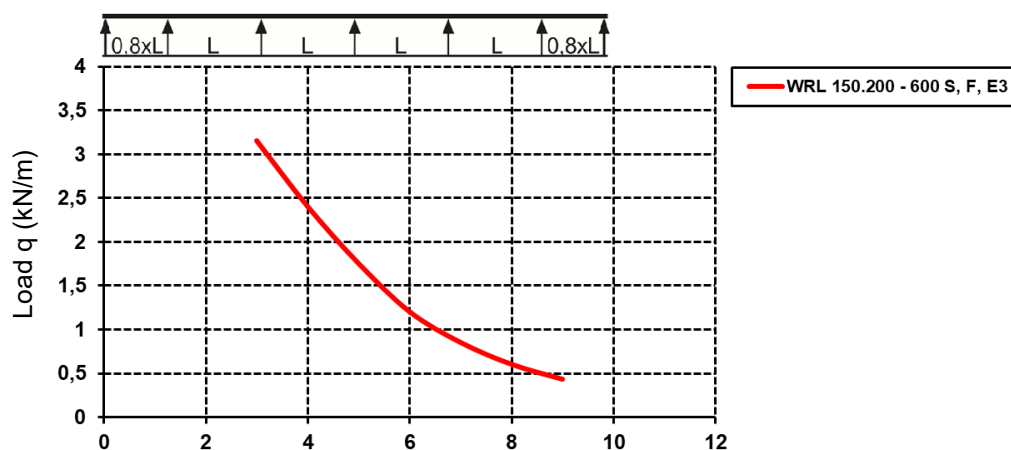

Fixing distance (m)

The load details shown in the diagram are independent of the position of the connectors.

Packing Dimension

6 meters = 1 piece		✓ VP1-smallest packaging unit (PU)		✓ VP1-preferred PU	
Lenght	6000 mm	Width	200.00 mm	Height	150.00 mm
Gross weight	44 kg	Volume	0,180 m ³		
Min. quantity	6.00 m	Max. Quantity	6.00 m		

60 meters = 1 bundle					
Lenght	6000 mm	Width	230 mm	Height	860 mm
Gross weight	438 kg	Volume	1,187 m ³		
Min. Quantity	60.00 m	Max. Quantity	60.00 m		

120 meters = 1 bundle					
Lenght	6000 mm	Width	460 mm	Height	860 mm
Gross weight	876 kg	Volume	2,374 m ³		
Max. Quantity	120.00 m	Min. Quantity	120.00 m		

Tender Text

Wide span cable tray, acc. to DIN EN 61537, with continuous perforated and beaded side rails, as well as riveted bottom with offset perforation and perforated cross beads for stabilisation and barrier strip fastening.

Please order splice plate WSV 150.500 separately.

Dimensions (approx. dimensions)

Height H x width W : 150 x 200 mm

Material thickness : 1.5 mm

Technical Datasheet

Long Span Cable Tray

WRL 150.200

the photorealistic images are to be considered as reference images

Tender Text

Cross section distance : 300 mm
Side rail perforation : 9.5 x 13 mm
Hole distance : 50 mm
Delivery length : 6000 mm
Usable cross-section : 24955 mm²
Material : steel, pre-galvanised acc. to DIN EN 10346
NIEDAX Model No. : WRL 150.200
EP material_____ EP wage_____
Unit price/meter

Safety & Environment

REACH Date	25.06.2025
REACH Info	Conformable
RoHS Info	Conformable

Origin & International Trade

Country of origin	DE
Customs tariff number	73089059

Related items

Cover

Model No.	Description
WDRS 20	Turning bolt with locknut acc. to DIN EN ISO 10511, for WSL/WRL, steel, pre-galvanised according to DIN EN 10346, incl. accessories
WDV 200	Cover for WSL/WRL, w. joint strip, 204x3000 mm, with turning lock, steel, pre-galvanised according to DIN EN 10346

Barrier strip

Model No.	Description
KLWC 16	Barrier strip fastening clamp, for 16 mm slot width, steel, pre-galvanised according to DIN EN 10346, incl. accessories
RW 110	Barrier strip, 98x3000 mm, t=0,9 mm, steel, pre-galvanised according to DIN EN 10346, incl. accessories

Connector

Model No.	Description
WSV 150.500	Splice plate, 151,5x500 mm, steel, pre-galvanised according to DIN EN 10346, incl. accessories

Accessories

Model No.	Description
WHAS 150 S	Wide span beam connection piece, height 150 mm, steel, pre-galvanised acc. to DIN EN 10346, incl. accessories