

Angle Connector

horizontal

WSWV 105.390

EAN Code: 4013339305377
 Smallest packaging unit: 10 pcs.

the photorealistic images are to be considered as reference images

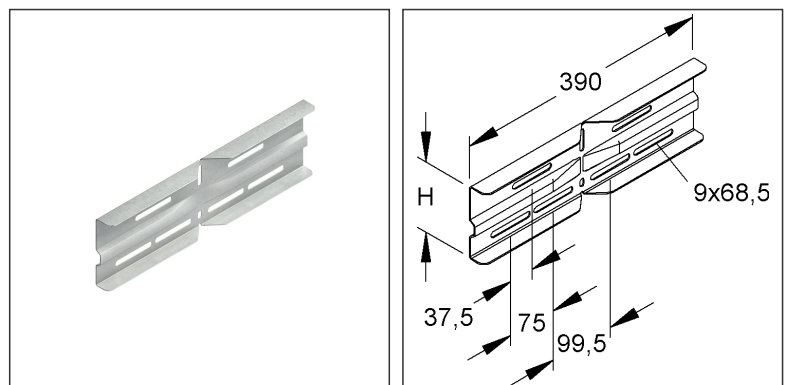

Article Description

Angle connector, horizontal, 106,5x390 mm, steel, pre-galvanised according to DIN EN 10346, incl. accessories

Incl. accessories

6 FLM 8X13 F

Additional Price Information

| | |
|---------------|------|
| Article group | N13 |
| quantity unit | pcs. |

Weight

| | |
|--------------------------|-----------------|
| Weight per quantity unit | 925 g / pcs. |
| Weight in kg per 100 | 92 kg / 100pcs. |

Technical Datasheet

Long Span Cable Tray

WSWV 105.390

the photorealistic images are to be considered as reference images

Physical Article Dimensions

| | |
|--------------|-----------|
| Height | 110.00 mm |
| Width | 30.00 mm |
| Depth/length | 390 mm |

Packing Dimension

| | | | | | |
|-----------------------------|------------|-------------------------------------|----------------------|--------------------|-----------|
| 10 pieces = 1 carton | | ✓ VP1-smallest packaging unit (PU) | | ✓ VP1-preferred PU | |
| Lenght | 425 mm | Width | 185.00 mm | Height | 120.00 mm |
| Gross weight | 9,7 kg | Volume | 0,009 m ³ | | |
| Min. quantity | 10.00 pcs. | Max. Quantity | 10.00 pcs. | | |

| | | | | | |
|------------------------------|-------------|---------------|----------------------|--------|---------|
| 600 pieces = 1 pallet | | | | | |
| Lenght | 1200 mm | Width | 800 mm | Height | 1000 mm |
| Gross weight | 597 kg | Volume | 0,960 m ³ | | |
| Min. Quantity | 600.00 pcs. | Max. Quantity | 600.00 pcs. | | |

Tender Text

Angle connector, horizontal, for creating horizontal angle connections of continuous wide span cable trays/ladders, including proportional fastening accessories in hot-dip galvanised. The equipotential bonding is achieved by bolting to the wide span cable tray/ladder beams as well as the fitting beams. Used for : wide span cable trays/ladders and their fittings with an edge height of 105 mm

Requirement : 2 pieces per joint

Dimensions (approx. dimensions)

Height H (clear inner dimension) x width W : 106.5 x 390 mm

Material : steel, pre-galvanised acc. to DIN EN 10346

NIEDAX Model No. : WSWV 105.390

EP Material _____ EP Wage _____

Unit price/piece

Safety & Environment

| | |
|------------|-------------|
| REACH Date | 25.06.2025 |
| REACH Info | Conformable |
| RoHS Info | Conformable |

Origin & International Trade

| | |
|-----------------------|----------|
| Country of origin | DE |
| Customs tariff number | 73089059 |