

Long Trough for all U-clamps

LW 34

EAN Code: 4013339113705
Smallest packaging unit: 100 pcs.

the photorealistic images are to be considered as reference images

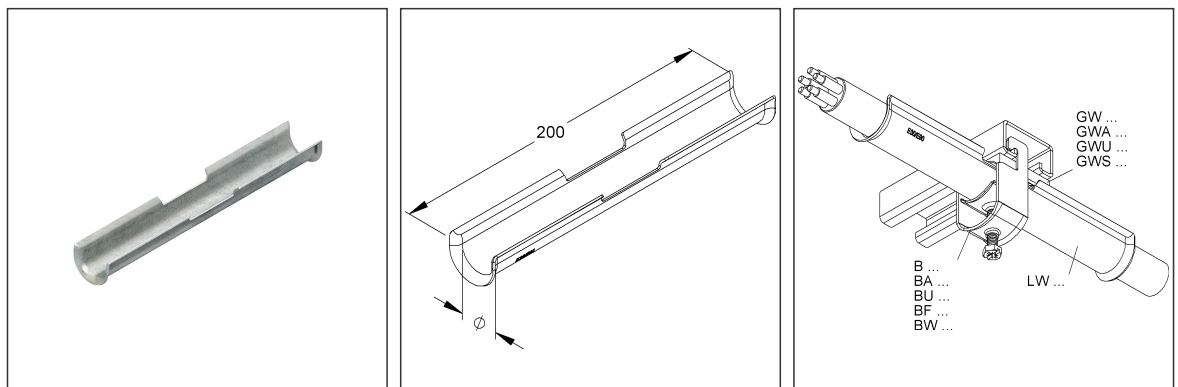
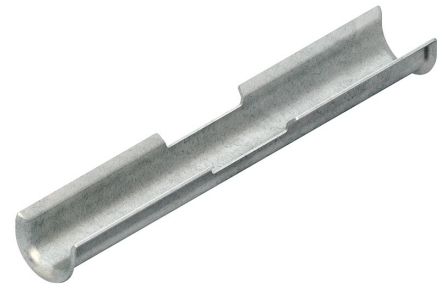

Article Description

Long trough, for cable-Ø 23-31 mm, steel, pre-galvanised according to DIN EN 10346

Additional Price Information

Article group	N08
quantity unit	pcs.

Weight

Weight per quantity unit	130 g/ pcs.
Weight in kg per 100	13 kg/ 100pcs.

Physical Article Dimensions

Height	27.90 mm
Width	40.00 mm
Depth/length	200.00 mm

Technical Datasheet

U-clamps

LW 34

the photorealistic images are to be considered as reference images

Packing Dimension

100 pieces = 1 carton		✓ VP1-smallest packaging unit (PU)		✓ VP1-preferred PU	
Lenght	350 mm	Width	250 mm	Height	145.00 mm
Volume	0,013 m ³	Gross weight	14 kg		
Min. quantity	100.00 pcs.	Max. Quantity	100.00 pcs.		
5000 pieces = 1 pallet					
Lenght	1200 mm	Width	800 mm	Height	1000 mm
Gross weight	693 kg	Volume	0,960 m ³		
Min. Quantity	5.000.00 pcs.	Max. Quantity	5.000.00 pcs.		

Tender Text

<p>Long trough, for all U-clamps, to increase the contact surface. Please observe additional regulations for use in functional maintenance! Used for :</p> <p>U-clamp B, BA, BU, BF ... and BW ... Functional integrity approved for : B ... and BU ... without counter trough C-profile rails with slot width : 11 - 12 mm, 16 - 17 mm and 18 - 22 mm Flat iron with material thickness t : 4 - 12 mm Angle steel, U-iron with a side length : 40 mm and t= 4 - 6 mm Dimensions (approx. dimensions) for cable-Ø : 23 - 31 mm Length L : 200 mm Material : steel, pre-galvanised acc. to DIN EN 10346 NIEDAX model no. : LW 34 EP material _____ EP wage _____ Unit price/piece</p>

Safety & Environment

REACH Date	25.06.2025
REACH Info	Conformable
RoHS Info	Conformable

Origin & International Trade

Country of origin	DE
Customs tariff number	73269098