

Overhead Hanger- and Wall Bracket

KTAC 100 S

EAN Code: 4013339192144
 Smallest packaging unit: 20 pcs.

the photorealistic images are to be considered as reference images

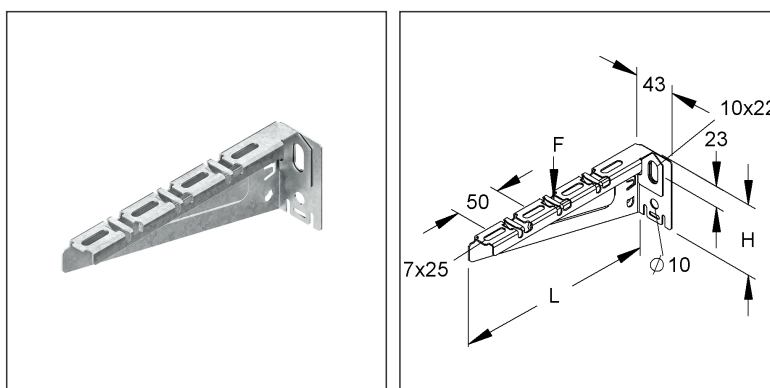
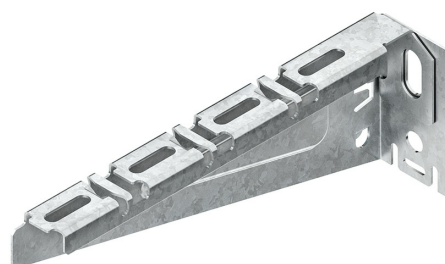

Article Description

Overhead hanger and wall bracket, 77x118 mm, 0.6 kN, steel, pre-galvanised acc. DIN EN 10346

Additional Price Information

Article group	N13
quantity unit	pcs.

Weight

Weight per quantity unit	130 g / pcs.
Weight in kg per 100	13 kg / 100pcs.

Physical Article Dimensions

Height	77.50 mm
Width	46.80 mm
Depth/length	118.00 mm

Technical Datasheet

Supporting structure

KTAC 100 S

the photorealistic images are to be considered as reference images

Packing Dimension

20 pieces = 1 carton		✓ VP1-smallest packaging unit (PU)	✓ VP1-preferred PU
Lenght	200.00 mm	Width	155.00 mm
Gross weight	2,53 kg	Volume	0,004 m ³
Min. quantity	20.00 pcs.	Max. Quantity	20.00 pcs.
2800 pieces = 1 pallet			
Lenght	1200 mm	Width	800 mm
Gross weight	367 kg	Volume	0,672 m ³
Min. Quantity	2.800.00 pcs.	Max. Quantity	2.800.00 pcs.

Tender Text

Overhead hanger and wall brackets, for wall and overhead mounting. The load-bearing capacity data only apply with sufficient anchoring to the load-bearing substrate or with correct installation on suspended supports.
 Can be used for : Wire mesh trays with a wire Ø 3.9 - 5 mm and a central longitudinal wire distance of 50 mm as well as for cable trays
 Dimensions (approx. dimensions) Support
 height H : 77 mm
 Support length L : 118 mm
 Load capacity F at L/2 : 0.6 kN tested in the system
 Material : steel, pre-galvanised acc. to DIN EN 10346
 NIEDAX Model no. : KTAC 100 S
 EP Material _____ EP Wage _____
 Unit price/piece

Safety & Environment

REACH Date	25.06.2025
REACH Info	Conformable
RoHS Info	Conformable

Origin & International Trade

Country of origin	FR
Customs tariff number	73089059