



AstroFan™ EC FFU

INSTALLATION, OPERATION, AND MAINTENANCE MANUAL

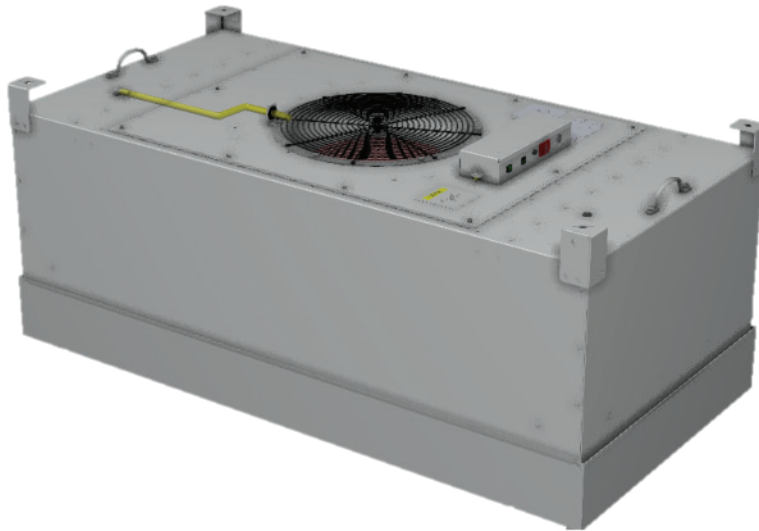
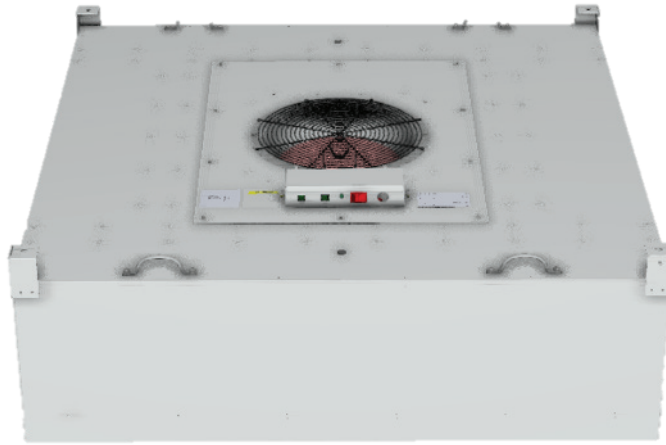

TABLE OF CONTENTS:

Introduction and Precautions	02
Important Safety Instructions	03
Equipment Overview	04
Transport	05
Unpacking	05
Installation.....	06
Top Side Serviceable Units	06
Room Side Replaceable Units	07
PermaFrame for Hard/Gypsum Ceiling	08
Grille Installation and Removal	09
Filter Unpacking, Installation, Storage and Operation	10
Unpacking	10
Installation of Gel Seal Filters	10
Storage	11
Operating Conditions.....	11
Aerosol Injection and Static Pressure/Upstream Aerosol Ports	11
Inlet Options	12
Insulation Options	12
Double Poly Bag Option	12
Power and Electrical	13
Wiring Diagram for EBM Blowers and AAF Control Interface	14
Appendix A – Warranty Information	15
Appendix B – Manual Revision History.....	16
Contacting AAF	Back Cover

INTRODUCTION AND PRECAUTIONS

Intended Use

AAF AstroFan™ EC Fan Filter Units (FFUs) ensure cleanroom-level cleanliness air is delivered to critical process applications such as Microelectronics, Semiconductor Manufacturing, Pharmaceutical Manufacturing, Life Sciences, Biosafety, Healthcare, as well as all other applications where clean supply air is a requirement.

User Responsibility

This document contains the information necessary to properly receive, assemble, install, operate, and maintain the AAF AstroFan EC FFU equipment. The purchaser, installer, and operator of the filter system MUST read and comply with this document in its entirety. Failure to comply with the requirements of this manual may result in serious injury, potentially death, and void the product warranty.

These instructions are specific to the AAF AstroFan EC FFU units and incorporated filters. All ancillary tasks including, but not limited to, electrical and mechanical work, equipment handling, and safety procedures must be performed in accordance with industry-accepted practice and all relevant local, state, and federal government codes, laws, and policies.







Before proceeding with installation, operation, or maintenance, review this Installation, Operation, and Maintenance Manual in its entirety and all safety procedures with your company's safety personnel.

Precautions

- Units must be properly transported and handled, as improper transport and/or handling can result in damage and/or blemishes.
- Deliveries are to be immediately inspected in the presence of the freight carrier to ensure equipment is delivered in full and damage-free.
- The installation site must be suitable for unit installation.
- The supporting construction must be level, and the structure must have sufficient load strength to support all equipment supplied.
- Mounting must be carried out by qualified and trained personnel in accordance with all local, state, and national codes and regulations.

IMPORTANT SAFETY INSTRUCTIONS

1. READ AND SAVE THESE INSTRUCTIONS

-  **2. WARNING – To reduce the risk of fire, electrical shock, or injury to persons, observe the following:**
- Use this unit in the manner intended by the manufacturer. If you have questions, contact the manufacturer.
 - Before servicing or cleaning unit, switch power off at service panel and lock the service disconnect means to prevent power from being switched on accidentally. When the service disconnect mean cannot be locked, securely fasten a prominent warning device, such as a tag to the service panel.
-  **3. WARNING – To reduce the risk of fire, electrical shock, or injury to persons, observe the following:**
- The AstroFan AFU fan filter units must be installed with filters that are marked on their labels to indicate the suitability with this model. Other filters cannot be substituted.
-  **4. CAUTION – Automatically operated device. To reduce the risk of injury, disconnect from power supply before servicing.**
-  **5. CAUTION – For installation by qualified personnel only.**
-  **6. WARNING – Risk of electrical shock. Can cause injury or death. Disconnect all remote electrical power before servicing. If connected to a circuit protected device by fuses, use time-delay fuses for this appliance.**
-  **7. WARNING – To reduce the risk of fire or electric shock, do not use this fan with any solid state speed control device.**
-  **8. WARNING – To reduce the risk of fire, electric shock, or injury to persons, observe the following:**
- Installation work and electrical wiring must be done by a qualified person(s) in accordance with all applicable codes and standards, including fire rated construction.
 - Follow the heating equipment manufacturer’s guideline and safety standards such as those published by the National Fire Protection Association (NFPA), and the American Society for Heating, Refrigeration, and Air Conditioning Engineers (ASHRAE), and the local code authorities.
 - When cutting or drilling into wall or ceiling, do not damage electrical wiring or other hidden utilities.
 - Ducted fans must always be vented to the outdoors.
 - If the unit is to be installed over a tub or shower, it must be marked as appropriate for the application and be connected to a GFCI (Ground Fault Circuit Interrupter) – protected branch circuit.

EQUIPMENT OVERVIEW

The AstroFan™ EC FFU (Fan Filter Unit) utilizes a state of the art Electronically Commutated (EC) Motor and backward-curved, plastic Blower Wheel assembly to provide the desired airflow through a HEPA/ULPA filter at an industry-leading efficiency and reduced sound level.

The AstroFan EC FFU is available in Aluminum or Stainless Steel options and as either a Top Side Serviceable (TSS) or Room Side Replaceable and Serviceable (RSR) configuration, white powder coat finish also available. For TSS, the AstroFan EC FFU housing sits on top of the HEPA/ULPA filter frame. For RSR, the housing sits on top of an RSR Filter Adaptor Frame (Extruded Aluminum), and the RSR Filter is installed from the room side.

AstroFan EC FFUs can be supplied with round duct inlet collars or with a prefilter frame. The latter is ideal for incorporating AMC (Airborne Molecular Contamination) filters. All units offer universal mounting via wire or rod suspension for use in a T-Bar grid ceiling, as well as a variety of grille options and insulation.

AstroFan EC FFUs are available in many configurations, sometimes with custom features. Please reference order specific data sheets and/or submittal drawings for more information.

EQUIPMENT OVERVIEW

Transport

Deliveries are to be immediately checked in the presence of the carrier as being intact and complete. Units must be properly transported. Improper transport can lead to:

- Impeller interference with inlet ring
- Motor shaft deformation
- Bearing damage

Unpacking

- Carefully remove the unit from the shipping carton and inspect for any damage that may have occurred during transportation. Two workers minimum are required to lift the unit from the container.
- Remove housing from shipping carton and inspect for concealed damage and any hardware that may have become loose in transit.
- If RSR configuration is ordered, the RSR Adaptor frame and grill will be shipped in a separate shipping carton and will need to be inspected for concealed damage and any hardware that may have become loose in transit.
- The grill for the RSR Adaptor should be set aside. It is good practice to label or mark the grill and trim components to match with the respective unit to ensure a good fit.

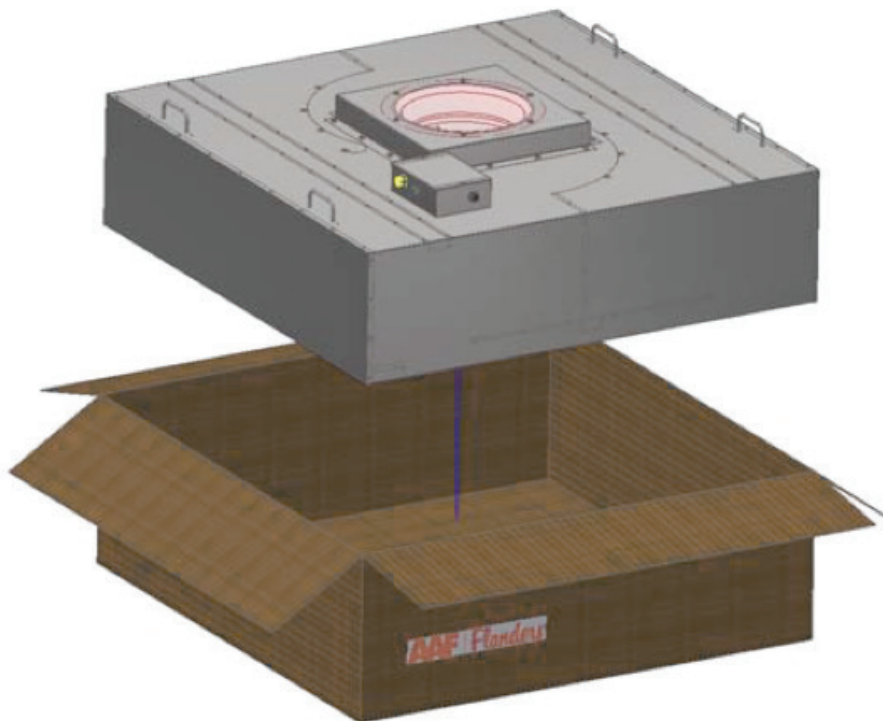

Fig 1: Unit Unpacking

INSTALLATION



CAUTION:

- Mounting may only be carried out by trained personnel in accordance with these instructions and with regards to regulations in force.
- Safety devices that have been removed for mounting work must be replaced immediately afterwards, and before electrical connections are made.
- Fans must be installed such that secured fixing is guaranteed at all times during operation.
- Installation site must be suitable for each AstroFan installed.
- Supporting construction must be level, and the structure must have sufficient load strength to support all fans as needed.
- All electrical connections must be made by qualified trained personnel only in accordance with all local, state, and national electrical codes and federal regulations.

If connecting flexible duct, connections should be made using stainless steel, worm-gear type draw bands (supplied by others) for maximum reliability. For square inlet, contractor is responsible for securing and sealing duct work to factory supplied blank flange. Housing installation must be accomplished in a professional manner to prevent contaminant infiltration from the interstitial space.

Top Side Serviceable Units

- Install the HEPA/ULPA filter into the ceiling grid such that the gasketed channel is pointing upward.
 - Extreme caution should be used when handling glass HEPA/ULPA filters to minimize any potential for damage.
- Using the integral handles, carefully lay the AstroFan™ unit onto the filter frame, ensuring its bottom edge rests in the gasketed channel of the filter frame. See Fig. 2.
 - It is recommended that two (2) people work together to ensure proper handling of units.
- If using a flexible grid (typically supported with wires or rod), the unit must be secured to an engineered support system, suspended with wire or rod (supplied by others) using the universal hanging tabs/mounting pads affixed to the housing. See Fig. 4.

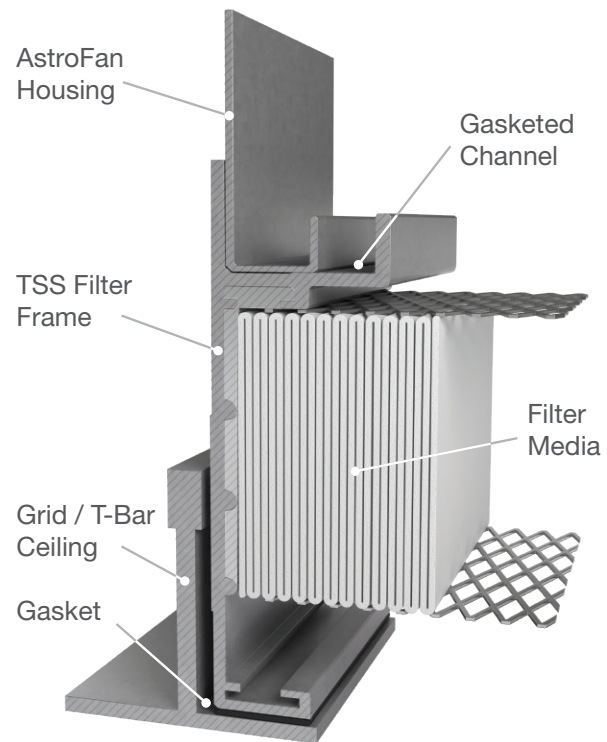

Fig 2: TSS Ceiling Grid Interface

INSTALLATION

Room Side Replaceable Units

- Install the RSR Adaptor Frame into the ceiling grid such that the gasketed channel is pointing upward.
- Using the integral handles, carefully lay the AstroFan™ unit onto the RSR Adaptor Frame, ensuring its bottom edge rests in the gasketed channel of the filter frame. See Fig. 3.
 - It is recommended that two (2) people work together to ensure proper handling of units.
- If using a flexible grid (typically supported with wires or rod), the unit must be secured to an engineered support system, suspended with wire or rod (supplied by others) using the universal hanging tabs/mounting pads affixed to the housing. See Fig. 4.

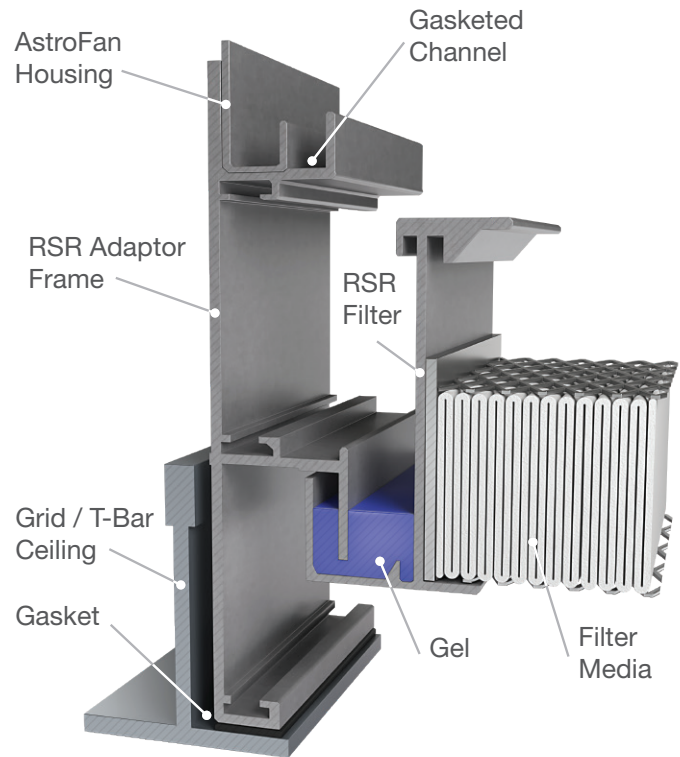

Fig 3: RSR Ceiling Grid Interface

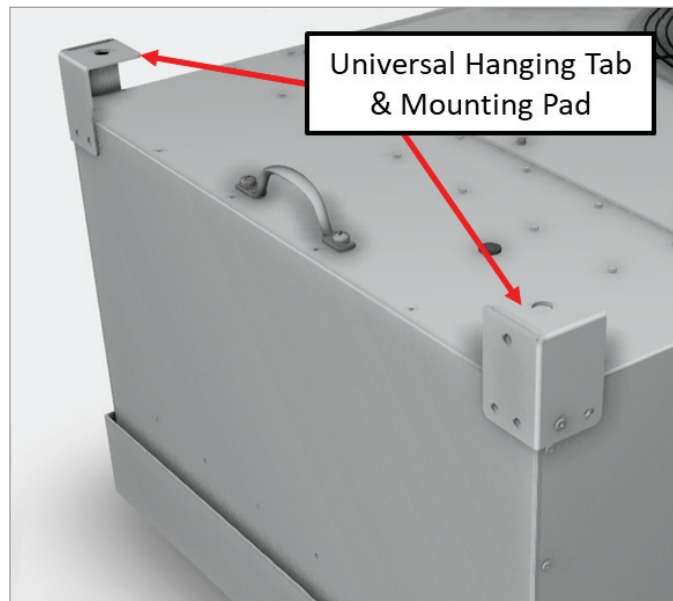

Fig 4: Wire - Hanging Tabs

INSTALLATION (CONTINUED)

PermaFrame for Hard/Gypsum Ceilings

The *PermaFrame* provides a support structure and room-side finish trim in one piece. It is supplied with predrilled mounting holes located on the vertical flanges, which are used to easily level and anchor the frame to customer-supplied studs above the ceiling structure. Manufactured of 16 gage cold rolled steel or stainless steel and welded on all exposed corners to guarantee a smooth, cleanable surface. White powder coat paint is supplied as standard finish. The *PermaFrame* is ordered separate from the AstroFan units and filters.

Dimensional Data - Standard Size AstroHood (1½" T-Bar)

AstroHood	Model Number	Actual Dimensions (inches)				Weight (lbs)
		L	W	IL	IW	
2 x 2	HCFA 2424	26	26	24	24	4
2 x 4	HCFA 2448	50	26	48	24	5

Drawing Notes:

Construction - 16-ga. cold rolled steel or 304 stainless steel.

For SS finish use - SS suffix, unit supplied painted white standard

IL - Inside Length

IW - Inside Width

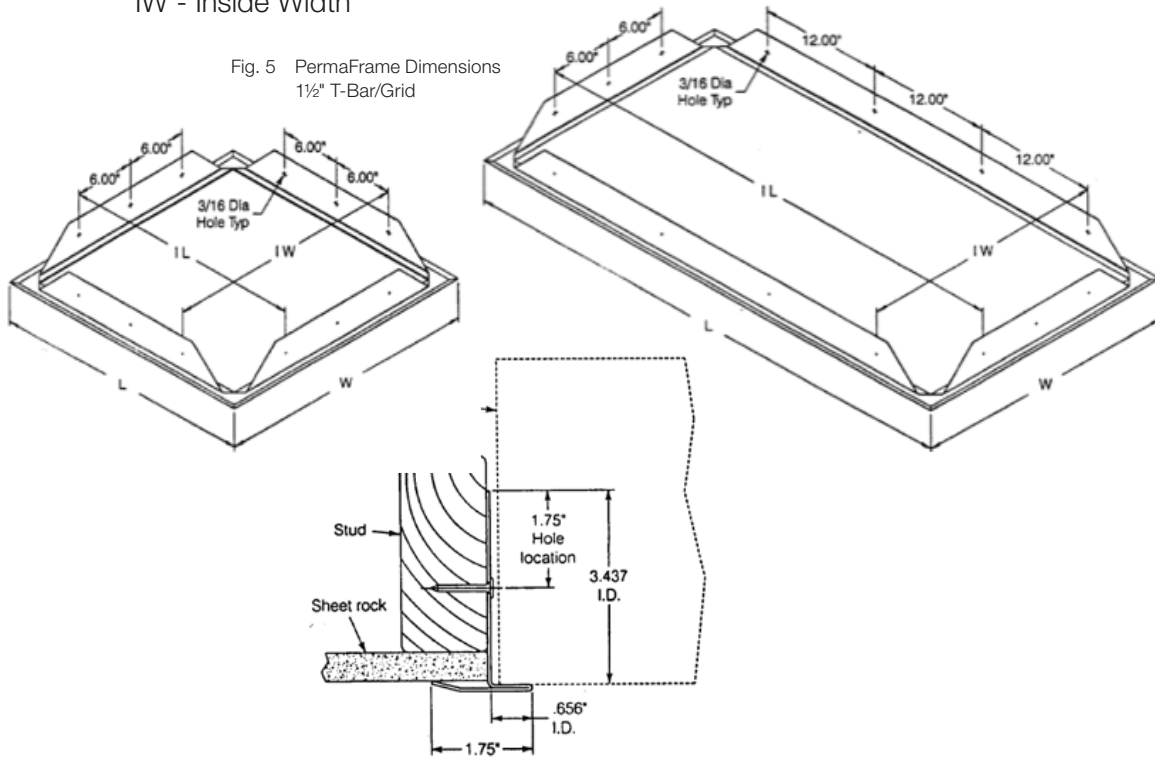

Fig. 6 PermaFrame Mounting

INSTALLATION (CONTINUED)

Grille Installation and Removal

The RSR unit is supplied with a standard removable grille made of 40% open area in Painted Steel, Aluminum, and Stainless Steel. Grille mounting is supplied as standard four (4) corner acorn nut design for 2x2 & 2x4 units and eight (8) acorn nuts for 3x4 & 4x4 units. The grille is fastened onto threaded studs using acorn nuts, one in each corner for 2x2 & 2x4 units and two along each side for 3x4 & 4x4 units (see Fig 7 below). The threaded studs protrude from the RSR Adaptor frame and through the grille to the room side. Acorn nuts and flat washers are installed on each stud to secure the grille in place.

To remove grille:

1. Loosen and remove the acorn nuts and flat washers.
2. Carefully remove and lower the grille. To avoid potential injury, it is strongly recommended two people perform this task.

To replace grille:

1. Align the holes in the grille with the studs.
2. Hold the grille in place and reinstall the flat washers and acorn nuts. To avoid potential injury, it is strongly recommended two people perform this task.
3. Hand-tighten the acorn nuts. Do not use a wrench or socket, as overtightening may damage the threaded connection.

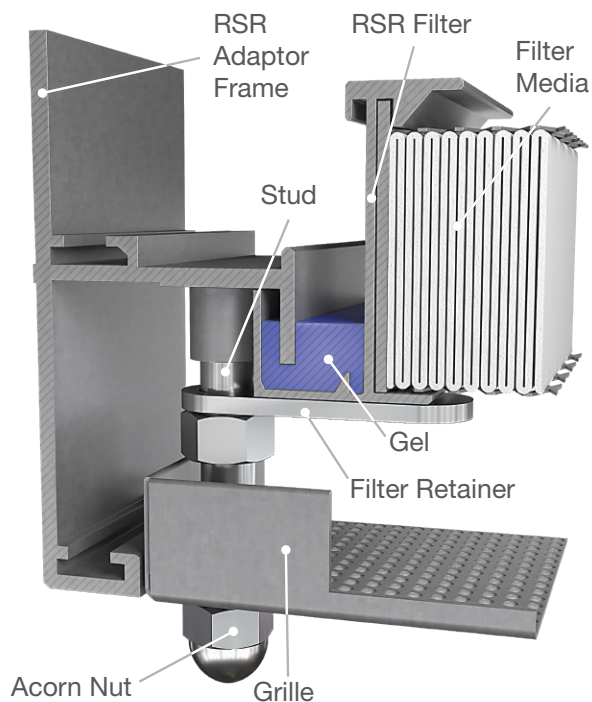

Fig. 7 Roomside Change Frame

FILTER UNPACKING, INSTALLATION, STORAGE AND OPERATION

Unpacking

- Before removing the filter from the carton, carefully read the removal and handling instructions printed on the outside of the carton.
- AAF Cleanroom filters may come packaged in suitcase-style cardboard sleeves. If so, simply reach into the box and grab the handles pre-punched within the insert.
- If the filter is in a cardboard liner, the filter must be oriented such that the open ends of the liner are facing outward (i.e. to your left and right rather than upward). Carefully cut the packing tape that holds the filter in the liner. Always check for torn or deflected liner edges. If any are found, straighten or flatten such edges prior to liner removal in order to prevent media damage.
- One person should carefully hold the plastic bag(s) while the other person carefully pulls the liner, sliding it away from the filter.
- Panel filters will be single- or double-bagged (depending on customer requirements) with snug-fitting cardboard liners. Ducted filters will be single or double bagged and packed in reinforced cartons.
- The filter should now be handled with extreme care to avoid contact with the media and/or face screen.
- While the bag is still present, carry the filter by grabbing the bag. Be careful to keep the filter away from your body and any objects in your path.
 - If the bag is not present, always handle filter from the frame, avoiding contact with the media and/or face screen.
- Remove the bag carefully. Avoid hand and finger contact with the filter media.
- Additional precautions for gel seal filters:
 - Care is taken at the factory to prevent the bag from contacting the gel. Be very careful when unpacking gel seal filters to remove the bag slowly and carefully.
 - If the bag comes in contact with the gel, pull the bag off the gel slowly. Quick removal of the bag may cause damage to the gel and possible separation of gel from the gel channel.

Installation of Gel Seal Filters

- Carefully lift the filter into place, inserting it into the housing and taking care to make certain the knife edge is properly seated into the fluid gel seal. Note: Setting filters properly requires two (2) people.
- Rotate each of the filter retainers into place, one (1) in each corner, and hand-tighten the hex nuts.
- Install the grille using the acorn nuts.

FILTER UNPACKING, INSTALLATION, STORAGE AND OPERATION (CONTINUED)

Storage

- Location: Storage should be indoors (under roof and enclosed) and absolutely protected from moisture.
- It is strongly recommended that the storage space be climate-controlled.
 - Temperature Limits: Maximum temperatures of 250°F (121°C) intermittent, and 100°F (38°C) steady state. Minimum temperature is 32°F (0°C).

Operating Conditions

- Temperature: The maximum operating temperature is determined by the filter configuration.
 - Consult the filter submittal drawing for the specific maximum operating temperature.
- Humidity: 100% relative humidity is acceptable. However, condensation must be avoided to prevent degradation of performance and potential filter failure.
- Filters should not be operated in caustic or acidic environments.
- Filters should not be operated in excess of twice the rated performance for flow rate or pressure drop.

Aerosol Injection and Static Pressure/Upstream Aerosol Ports

The AstroFan™ EC FFU RSR is supplied with room-side aerosol injection port and aerosol dispersion system as well as an upstream static pressure/upstream aerosol sample port to facilitate validation testing. These ports are available standard as 3/8" female NPT fittings, supplied with respective plugs. These connection points are labeled on the inside surface of the housing and are visible from the room side.

To remove grille:

1. Loosen and remove the acorn nuts and flat washers.
2. Carefully remove and lower the grille. To avoid potential injury, it is strongly recommended two people perform this task.

To replace grille:

1. Align the holes in the grille with the studs.
2. Hold the grille in place and reinstall the flat washers and acorn nuts. To avoid potential injury, it is strongly recommended two people perform this task.
3. Hand-tighten the acorn nuts. Do not use a wrench or socket, as overtightening may damage the threaded connection.

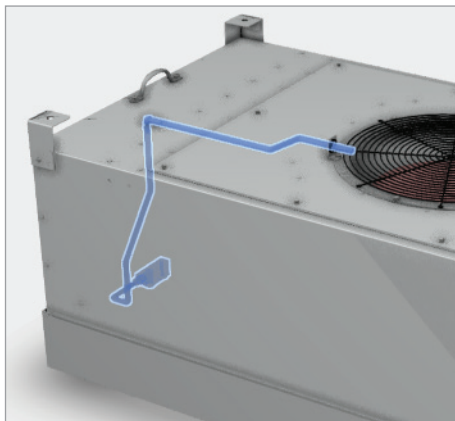

Fig. 8 Aerosol Injection System

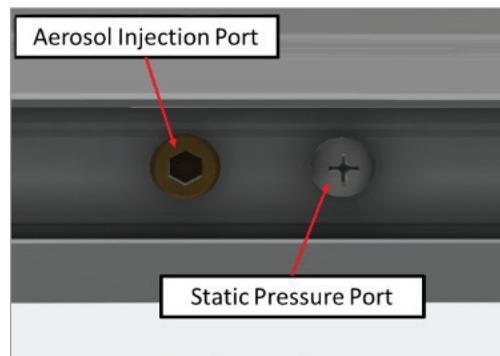

Fig. 9 3/8" NPT Ports

FILTER UNPACKING, INSTALLATION, STORAGE AND OPERATION (CONTINUED)

Inlet Options

The AstroFan™ EC FFU is available as standard for plenum supply applications and is also available with the option for prefiltration, either particulate or AMC, or in a ducted supply configuration. The prefilter option is designed to accommodate standard 20"x20"x2" pleated prefilters. The ducted supply option is available as either a 20"x20" square or round duct connection

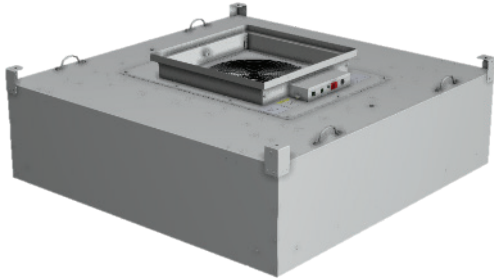

Fig. 10 PreFilter/Square Duct Option

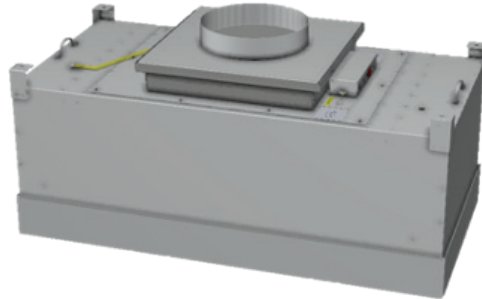

Fig. 11 Round Duct Option

Insulation Options

Insulation options are available to prevent heat loss, mitigate potential condensation, and/or provide sound attenuation. Determining the use of these options is the responsibility of the design engineer.

The 2" foil back option is an aluminum foil-backed fiberglass (installed 6.0 R-value) attached to the outside of the housing using adhesive-mounted insulation anchors and caps.

Double Poly Bag Option

A double poly bag arrangement is available for those clients whose cleanrooms are ultra-sensitive to potential contamination exposure. The double-bagged FFU housing is removed from the container outside of the cleanroom. At a staging area, typically in an area of lesser cleanliness than the cleanroom such as an ante room, the single-bagged FFU housing is removed from the outer bag and then taken into the cleanroom. Inside the cleanroom, the FFU housing is removed from the second bag and staged for installation.

FILTER UNPACKING, INSTALLATION, STORAGE AND OPERATION (CONTINUED)

Power and Electrical

Install wires and make electrical connections to appropriate voltage, matching the nameplate information on unit. Install wires in accordance with all local, state, and nation electrical codes.

Power into the unit should be connected to the L1, L2, and Ground pins on the power terminal block. Appropriate gauge wire, cabling, and strain relief should be utilized per governing code. It is highly recommended that power be supplied to each unit discretely.

Communication with the motor can be established by attaching CAT 5, CAT 5E, or CAT 6 cable to COMS 1 or 2 from the AstroDrive Control or BMS. Note the ethernet cables are throughput, not series, and are not directional – you can use either one. Cables can then be attached to subsequent units, in series, to control more than one FFU; however, this is limited to 1,300 feet as communication loss will be incurred. Please refer to the AstroDrive controls manual for appropriate communications wiring configuration.

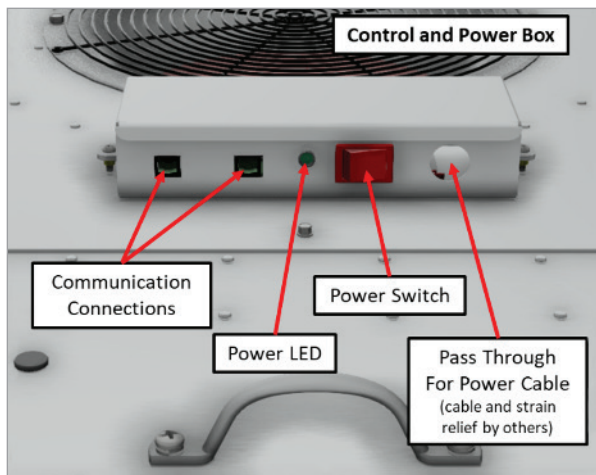

Fig. 12 Control Box

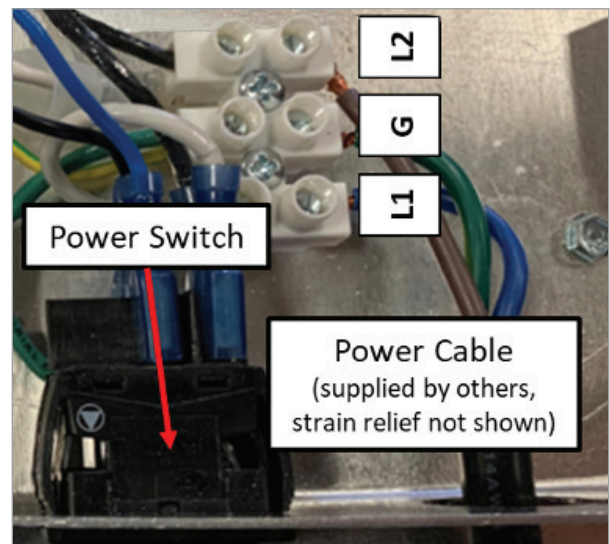
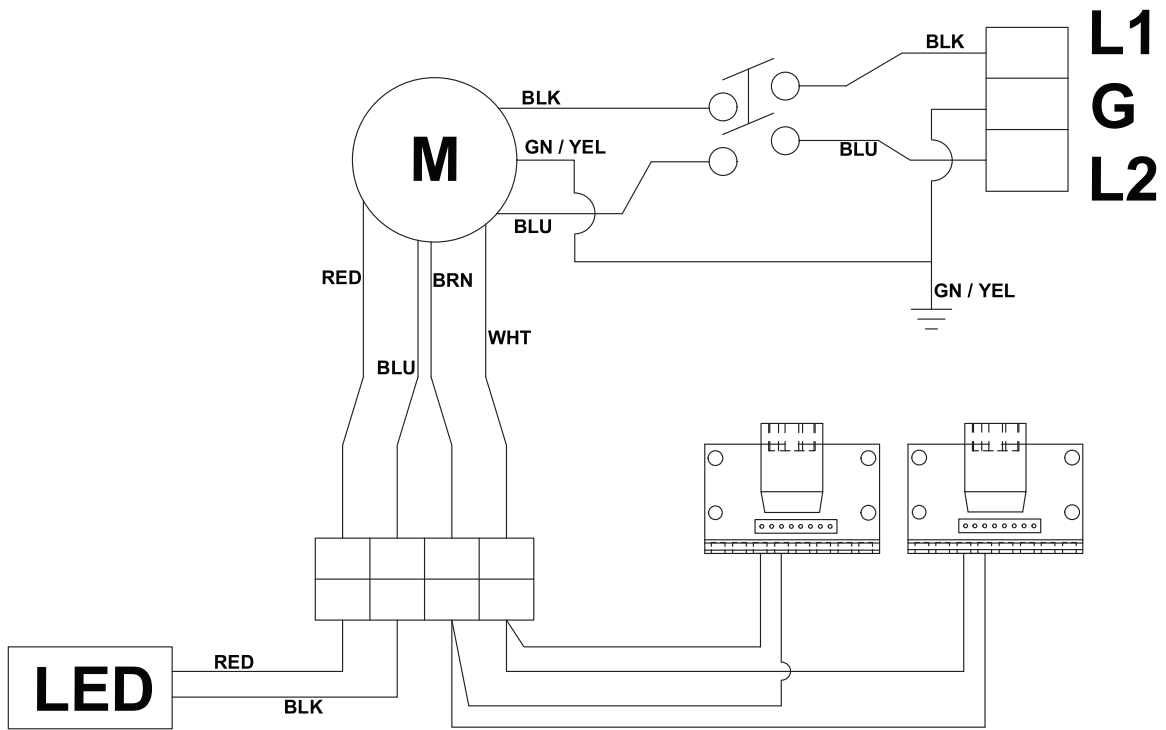

Fig. 13 Power Wiring

WIRING DIAGRAM FOR EBM BLOWERS AND AAF CONTROL INTERFACE



WIRING DIAGRAM

APPENDIX A – WARRANTY

AAF INTERNATIONAL LIMITED WARRANTY

The Seller warrants that it will provide free replacement parts in the event any product manufactured by the Seller proves defective in material or workmanship for a period of twelve (12) months from initial startup or eighteen (18) months from date of shipment, whichever expires sooner. Product(s) not manufactured by the Seller but also sold under this agreement are warranted only to the extent that the manufacturer warranted them to the Seller or directly to Buyer.

The Seller's liability to Buyer shall not exceed the lesser of the cost of correcting defects in the product(s) sold or the original purchase price of the product(s), and the Seller shall in no event be liable to Buyer or third parties for any delays. The Seller's warranty does not apply to any product(s) or goods which: (1) have been opened, disassembled, repaired, or altered by anyone other than the Seller or its authorized service representative; or (2) which have been subjected to misuse, misapplication, negligence, accidents, damage, abuse, improper storage, or abnormal use or service; or (3) have been operated or installed in a manner contrary to Seller's printed instructions; or (4) have been installed in an incorrect or improper application; or (5) have become corroded or subjected to abrasion. The Seller is not obligated to pay any costs or expenses in connection with the removal and re-installation of such product(s) or goods, including but not limited to labor, service costs, and shipping charges. The same obligations and conditions shall extend to replacement parts furnished by the Seller hereunder. This parts warranty and any optional extended warranties are granted only to the original user. Seller's duty to perform under this or any warranty may be delayed, at Seller's sole option, until Seller has been paid in full for all products or goods purchased by Buyer. No such delay shall extend the warranty period.

To obtain assistance under this limited warranty please contact the selling agency. To obtain information or to gain factory assistance, contact AAF International Warranty Claims Department, 9920 Corporate Campus Drive, Suite 2200, P.O. Box 35690, Louisville, Kentucky 40223-5000; Telephone (502) 637-0011, FAX (888) 223-6500.

THIS WARRANTY CONSTITUTES BUYER'S SOLE REMEDY. IT IS GIVEN IN LIEU OF ALL OTHER WARRANTIES, EXPRESS OR IMPLIED. THERE IS NO IMPLIED WARRANTY OF MERCHANTABILITY OR FITNESS FOR A PARTICULAR PURPOSE. NOTWITHSTANDING ANY OTHER TERMS OF ANY AGREEMENT BETWEEN THE SELLER AND BUYER, IN NO EVENT AND UNDER NO CIRCUMSTANCES SHALL SELLER BE LIABLE FOR INCIDENTAL, INDIRECT, SPECIAL, OR CONSEQUENTIAL DAMAGES, WHETHER THE THEORY BE BREACH OF THIS OR ANY OTHER WARRANTY, BREACH OF CONTRACT, NEGLIGENCE, OR STRICT LIABILITY.

No person (including any agent, salesman, dealer, or distributor) has the authority to expand the Seller's obligation beyond the terms of this express warranty, or to state that the performance of the product(s) is other than published by the Seller.

APPENDIX B – MANUAL REVISION HISTORY

Revision Version	Revision Date	Description of Change	Approval

For Technical or Application Questions:

Phone: 1 (888) 223-2003

Email: productsupport@aafintl.com



AAF International Plant Locations

AAF, the world's largest manufacturer of air filtration solutions, operates production, warehousing and distribution facilities in 22 countries across four continents. With its global headquarters in Louisville, Kentucky, AAF is committed to protecting people, processes and systems through the development and manufacturing of the highest quality air filters, filtration equipment, and associated housing and hardware available today.

Contact your local AAF representative for a complete list of AAF Air Filtration Product Solutions.

Americas

Louisville, KY
Atlanta, GA
Ardmore, OK
Bartow, FL
Columbia, MO
Fayetteville, AR
Hudson, NY
Momence, IL
Smithfield, NC
Tijuana, Mexico
Votorantim, Brazil
Washington, NC

Europe

Cramlington, UK
Gasny, France
Vitoria, Spain
Ecoparc, France
Trencin, Slovakia
Vadstena, Sweden
Vantas, Finland

Asia & Middle East

Riyadh, Saudi Arabia
Shah Alam, Malaysia
Suzhou, China
Shenzhen, China
Miaoli, Taiwan
Bangalore, India
Noida, India
Yuki, Japan (Nippon Muki)



9920 Corporate Campus Drive, Suite 2200, Louisville, KY 40223-5690
888.223.2003 Fax 888.223.6500 | aafintl.com

AAF has a policy of continuous product research and improvement. We reserve the right to change design and specifications without notice.

©2023 AAF International and its affiliated companies.

ISO Certified Firm

AFP-3-103 12/23