



HEGA Filters

**(Disposable, Replaceable, or Refillable Adsorbers for
the Control of Dangerous Gaseous Contaminants)**

TABLE OF CONTENTS

Table of Contents	2	Cinersorb	13
Important Message	3	Suggested Specifications and Ordering Info for Cinersorb	14
Quality Assurance	4	Diagram: Model Number Breakdown	
Introduction	5	Chart: Gel Seal Housings	
What is a HEGA?		Chart: Gasket Seal Housings	
Where are HEGAs Used?		Carbon Sampling Systems	17
How Does a HEGA Work?		Carbon Sampling Canisters	
HEGA Selection		Radioactive Iodine Performance Test	
Design	6	Types of Adsorption	
Design Considerations		Efficiency vs. Penetration	
Diagram: V-Bed Adsorber Applications		Residence Time	
V-Bed Adsorbers	7	Capacity	
Carbon Adsorbers		Decontamination Factor	
Residence Time		Design Principles for Filtering Dangerous Chemical Contaminants	
Applications		User Guide	22
Adsorber Design and Performance		Handling /Unpacking, Storage, Operating Conditions	
Stainless Steel Frame Adsorbers	8		
Adsorber Housings			
Type IV (V-Bed) Stainless Steel Frame Adsorbers			
Suggested Specifications for Type IV Stainless Steel Adsorbers	9		
Ordering Information			
Diagram: Model Number Breakdown			
Ordering Information	10		
Type IV (V-Bed) Stainless Steel Adsorbers			
Chart: Full-Size Gel Seal Adsorbers			
Chart: Full-Size Gasket Seal Adsorbers			
Type IV (V-Bed) Stainless Steel Adsorbers - Small Size			
Chart: Small Size Stainless Steel Gel Seal Adsorbers - Activated Carbon			
Chart: Small Size Stainless Steel Gasket Seal Adsorbers - Activated Carbon			
Chart: Small Size Stainless Steel Gel Seal Adsorbers - Nuclear Grade Carbon			
Chart: Small Size Stainless Steel Gasket Seal Adsorbers - Nuclear Grade Carbon			

IMPORTANT MESSAGE



NOTICE: Compliance with installation and operation standards must be met to ensure quality performance.

HEGA filters are factory-tested to meet the requirements of IES RP-CC-008- 84, "Recommended Practice for Gas Phase Adsorber Cells."

Test results appear on both the filter label and upon the filter carton label. An additional quality assurance test report is kept on file and is available on request.

AAF recommends that all HEGA and HEPA filters be tested in place by qualified personnel to ensure that the filters have been correctly installed in the containment housing.

AAF service personnel are available for installations, supervision of installation, testing, and certification of compliance with industry and government standards and instruction of the owner's personnel in testing and maintenance procedures.

AAF does not guarantee that its equipment will operate at the performance levels given on the identification labels or in the catalog specifications under all conditions of installation and use, nor does AAF guarantee the suitability of its product for the particular end use that may be contemplated by the buyer.

For best results, it is recommended that the buyer supply complete information about the operating conditions of the ventilation system to AAF for evaluation. When the system components are supplied to the buyer or an agent for final installation and assembly in the field, it should be under the supervision of factory-trained personnel.

When the system components are supplied to the buyer or an agent for final installation and assembly in the field, it should be under the supervision of factory-trained personnel.

Failure to adhere to this recommendation or failure of the buyer to have filters retested and serviced in a timely fashion with nullify or limit any warranties that might otherwise apply and may result in a compromised installation.

NOTE: Throughout the AAF product bulletins we make reference to standards that may appear old and/or revised. Our purpose in specifying the older versions of standards is due to the nature of these products and where they are typically used.

During the years and numerous revisions, these standards have become less stringent than their original versions. We believe in manufacturing and referencing the critical versions to help the owners maintain the stringent requirements this industry originally intended.

Quality Assurance Program

Any industry that has dangerous process or exhaust gases and/or particulates has a vital concern for the health and safety of personnel. In addition to corporate concern, the United States Government has dictated that safety equipment must meet minimum safety standards. Any equipment sold to meet these minimum standards has to be manufactured using accepted Quality Control procedures.

AAF has developed a Quality Assurance program to assure that the product or service provided meets these standards. This program addresses the entire range of AAF's involvement, including the purchase of raw materials, the storage of these raw materials, incorporation of these materials into a product or service, testing this product or service, and then shipping it to its destination.

The program of AAF has been audited many times, and each time the program has passed. An uncontrolled copy of the program manual is available with each request for Quality Assurance information. Like any dynamic document, the program is continually being revised to include recent issues of standards and specifications so that AAF may use the latest state-of-the-art methods in providing its products and services.

The Quality Assurance Program at AAF has been audited and approved several times by the Nuclear Utilities Procurement and Inspection Committee, NUPIC. This committee was established by nuclear electric utilities to ensure that suppliers of goods and services can meet all applicable regulatory and quality requirements.

Notes:

1. As part of our continuing program to improve the design and quality of all our products, we reserve the right to make such changes without notice or obligation.
2. AAF, through its limited warranty, guarantees that the products described herein will meet all specifications agreed to by the buyer and the seller.
3. ASME N509 *Nuclear Power Plant Air-Cleaning Units and Components*.
4. ASME N510 *Testing of Nuclear Air Treatment Systems*.

AAF HEGA Filters: Introduction

What is a HEGA?

To be called a High-Efficiency Gas Adsorber (HEGA), the adsorber must exhibit a minimum mechanical efficiency of 99.9% when tested in accordance with the Institute of Environmental Sciences designation: IES-RP-CC-008-84, "Recommended Practice for Gas Phase Adsorber Cell." In addition, the adsorber must be designed, built, filled, and packaged in accordance with the intent of this standard.

Since HEGA filters are manufactured in several different sizes and of several different materials, this standard is not always followed to the letter. It is the intent of the standard and the resulting performance of these adsorbers that is important. This type of adsorber is not intended to be used in odor control systems. However, if the user needs a very efficient odor control system and can justify the higher initial and operating costs, then this type of adsorber will do an excellent job. The following comparison between an odor control type adsorber vs. a HEGA may help:

Comparing an odor control type of adsorber to a HEGA is like comparing an ASHRAE type of particulate filter to a HEPA. The odor control type of adsorber (like the ASHRAE type of particulate filter) is less efficient, has a lower pressure drop, and costs less. On the other hand, the HEGA (like the HEPA) is more efficient, has a higher pressure drop, and costs more. Both adsorbers have their place in industry, but because of these major differences, they are not usually interchangeable.

How Does a HEGA Work?

A High Efficiency Gas Adsorber (HEGA) filters gaseous contaminants from an airstream by adsorbing the contaminants (see page 19, "Types of Adsorption"). With a properly designed system that includes proper adsorber selection, adsorbent, and resident time, any adsorbable contaminant can be filtered and contained. (see page 7 for "Adsorber Design and Performance." page 20, "Residence Time").

Where are HEGAs Used?

HEGAs are most often used in "containment" air filtration systems. Containment air filtration systems are very high-efficiency systems used to filter and contain dangerous particulate and/ or gaseous contaminants. Containment systems are most often designed to treat exhaust air from contaminated spaces but occasionally are used in supply and recirculated air systems. Examples of facilities using these systems are:

- Nuclear Power Plants
- Cancer Research Laboratories
- Toxicology Laboratories
- Animal Disease Research Facilities
- Chemical Agent Research Facilities
- Bomb Shelters (CBR)
- Radiopharmaceutical Plants
- HVAC Systems
- Laboratories Using Chemical Carcinogens
- Chemical Agent Munitions Disposal Facilities
- Hospital Isolation Suites
- Pharmacological Facilities
- Chemical Process Facilities
- Military Facilities
- Biological Research Facilities
- Department of Energy Facilities

HEGA SELECTION

When designing a system requiring HEGAs, consider:

1. Type: "Cinersorb" (p. 13), Type IV (V-Bed) (p. 7)
2. Type of carbon needed (p. 6 & 7)
3. Residence Time: (See pp. 7 & 20)
4. Need for sample canisters (See p. 19)

AAF HEGA Filters: Design Considerations

The following should be considered when designing a filtration system:

1. Any system that filters dangerous contaminants should incorporate bag-in/ bag-out housings to contain the contaminated filters and protect maintenance personnel during filter change-out
2. Particulate filtration must be provided upstream of HEGA filters to prevent the adsorber from trapping particulates, thereby increasing the adsorber's pressure drop and decreasing its efficiency.
3. Some applications require high-efficiency or HEPA filters located downstream of the adsorber to collect any fines (dust which might be contaminated) released from the adsorbent material and to act as a backup in case the first particulate filter should fail.
4. Filter trains can be easily constructed with any combination of roughing filters, high-efficiency filters, HEPA filters, and adsorbers (see illustration below).
5. An in-place test of both adsorbers and HEPA filters is recommended for nuclear containment systems and is becoming a more frequent requirement for many critical applications. The purpose of this in-place testing is to "validate" the installed system. The in-place test, if required, should be discussed with a AAF factory representative prior to the selection of equipment, so the system will be correctly designed to facilitate the test. In-place test equipment and service personnel are available from AAF to assist in the original installation and testing.
6. The filtration system should be manufactured under a quality assurance program that addresses all of the basic requirements of ASME NQA-1, "Quality Assurance Program Requirements for Nuclear Facilities."

V-Bed Adsorber Applications

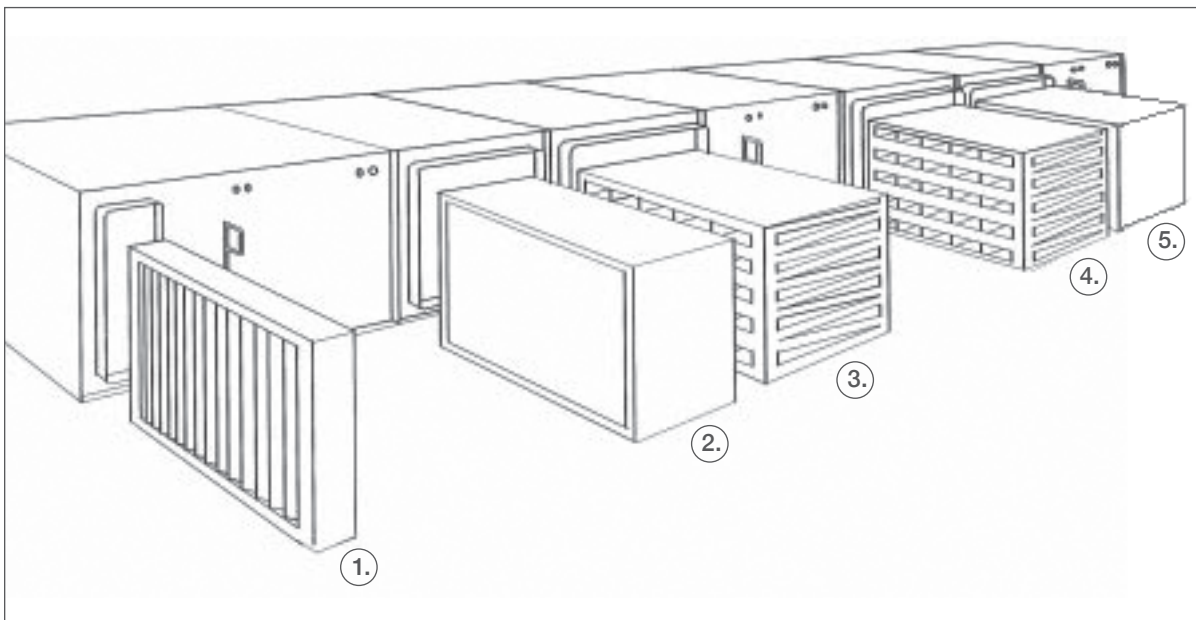

From left to right:

1. Prefilter, upstream in-place test section
2. HEPA filter
3. V-bed adsorber, in-place combination test section
4. V-bed adsorber
5. HEPA filter, downstream in-place test section

AAF HEGA Filters: V-Bed Adsorbers

Carbon Adsorbers

Carbon adsorbers use activated or impregnated /activated carbon as a filtering medium to remove gaseous emissions from nuclear, biological, and/or chemical process exhaust air. Due to the potentially hazardous nature of their end use, the customer should consult with AAF technical representatives as early as possible during the design phase of a project to assure proper specifications for the adsorbers and the filtration system. AAF personnel have many years experience with gas-phase and HEPA filtration systems and can provide assistance in adsorbent selection, residence time calculations, and system configuration.

All units are manufactured in accordance with AAF's quality assurance program, which meets the requirements of ASME-NQA-1, "Quality Assurance Program Requirements for Nuclear Facilities." AAF tests each adsorber to insure a minimum mechanical efficiency (the percentage of air that actually contacts the activated carbon in a system without penetrating voids or cracks) of 99.9% per IES-RP-CC-008-84, "Recommended Practice for Gas-Phase Adsorber Cells." This test of the adsorber's efficiency on test agents is used to determine if the adsorber is properly manufactured and filled, but not whether it is suitable for a given application.

Residence Time

Under actual operating conditions, the removal efficiency (the percentage of containment actually removed by the activated carbon during operation) of an adsorber is determined by the type and amount of contaminant in the gas stream, the type and amount of adsorbent, and the residence time (the time that the gas stream is in contact with the carbon). In most applications, a residence time of 0.125 second is sufficient. In other cases, residence time is a critical factor that must be calculated for the specific contaminant (see p. 20).

Applications

Type IV (V-Bed) adsorbers are designed for use in AAF BF-Series and BG-Series bag-in/bag-out housings, and for use in KF-Series high-efficiency side-service housings. Occasionally they are used in large "front and rear loading" built-up banks inside walk-in plenums, but the Type II Tray adsorber is usually best suited for that system design.

Adsorber Design and Performance

All units are made with beds of carbon mounted in a "V" configuration at various depths and residence times at rated airflow depending upon customer requirements. Various grades of carbon are available to meet specific removal requirements:

Designation A = Activated 8 x 16 mesh carbon is used to adsorb heavy solvents, elemental iodine, and most odors. This carbon is specified as follows:

The activated carbon shall be coconut shell base, 8 x 16 mesh and shall have a minimum carbon tetrachloride (CTC) activity of 60% when tested in accordance with ASTM D3467. The carbon shall meet the "base" carbon requirements for nuclear grade carbon.

Designation N = Nuclear grade 8 x 16 mesh carbon is specially impregnated activated carbon used to adsorb organic radioiodides. This carbon is specified as follows:

The nuclear grade carbon shall be coconut shell base, 8 x 16 mesh that meets the requirements of ASME N509-1996 "Reaffirmed," Section 5.2.

Designation T = ASZM-TEDA (Cooperite) 12 x 30 mesh carbon used to adsorb toxic warfare gases. Performs similar to Whetlerite. Impregnants do not include chromium.

The activated carbon shall be specially impregnated coal base that meets the requirements of EA-DTL-1704A.

Other media available to meet design requirements.

Note: Carbon adsorbers can be "poisoned" by paint fumes and other gases commonly found in many facilities, so they must be carefully protected when stored. The customer should consult the factory representative regarding storage precautions.

AAF HEPA Filters: Stainless Steel Frame Adsorbers

Adsorber Housings

V-Bed carbon adsorbers are manufactured in standard sizes for use in bag-in/bag-out and side-load housings, and are available in both gel seal and gasket seal designs. AAF manufactures a complete line of housings for adsorbers and HEPA filters. Contact the factory or your AAF representative for complete information on adsorbers and HEPA filter housings.

Type IV (V-Bed) Stainless Steel Frame Adsorbers

Description

The AAF Type IV (V-Bed) adsorber is designed with either 1-inch, 1 3/8-inch, or 2-inch thick beds arranged in a V-Bank configuration. This design allows a high airflow at a relatively low pressure drop. Adsorber frames are constructed of T-304 stainless steel with T-304 stainless steel perforated screens.

These adsorbers are designed for use in AAF G-Series, BF-Series, and BG-Series bag-in/bag-out housings, and for use in KF-Series efficiency side-serving housings.

These adsorbers are manufactured under stringent quality control procedures. Each adsorber is filled, tested, and packaged in accordance with IES Designation: RP-8 (IES-RP-CC-008, "Recommended Practice for Gas Phase Adsorber Cells"). Before shipping, each adsorber is tested in accordance with this standard to assure a minimum mechanical efficiency of 99.9%.



Type IV Stainless Steel Frame Adsorber

Features

- Minimum mechanical efficiency of 99.9% when tested in accordance with IES Designation: RP-8 (IES-RP-CC-008, "Recommended Practices for Gas-Phase Adsorber Cells"). Higher efficiencies available when required.
- Designed, manufactured and tested under a Quality Assurance Program that meets the basic requirements of ASME NQA-1, "Quality Assurance Program Requirements for Nuclear Facilities."
- Available in several standard sizes allowing use in standard filter housings.
- Corrosion resistant.
- Can be filled with appropriate adsorbent to capture any adsorbable contaminant.
- Many applications: Treat exhaust air from safety cabinets, glove boxes, and fume hoods; supply air to inhalation labs, etc.

AAF HEGA Filters: Suggested Specifications Type IV Stainless Steel Adsorbers

From the tables on Pages 9 - 12, fill in the blanks for adsorber requirements.

Adsorber shall be AAF model number _____.

Adsorber frame shall be constructed of 14-gauge T-304 stainless steel and have _____ beds that are _____ deep, arranged in a V-bank configuration.

The filter frame shall be size: _____" high x _____" wide x _____" deep, and have _____ (gel/gasket) seal on one side.

The rated flow shall be _____ CFM at approximatel _____" w.g. pressure drop and _____ -second residence time.

Adsorber screens shall be perforated 26 gauge T-304 stainless steel supported by external spacers to prevent distortion during filling with carbon. Adsorber shall exhibit a minimum mechanical efficiency of 99.9% when tested in accordance with IES-RP-CC-008-84, "Recommended Practice for Gas-Phase Adsorber Cells." Units shall be designed, manufactured, and tested under a Quality Assurance Program that meets the requirements of ASME NQA-1, "Quality Assurance Program Requirements for Nuclear Facilities."

Model Number Breakdown (Example)

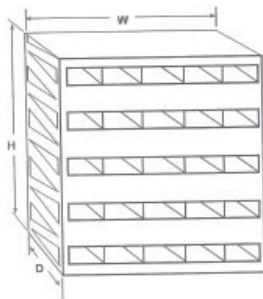
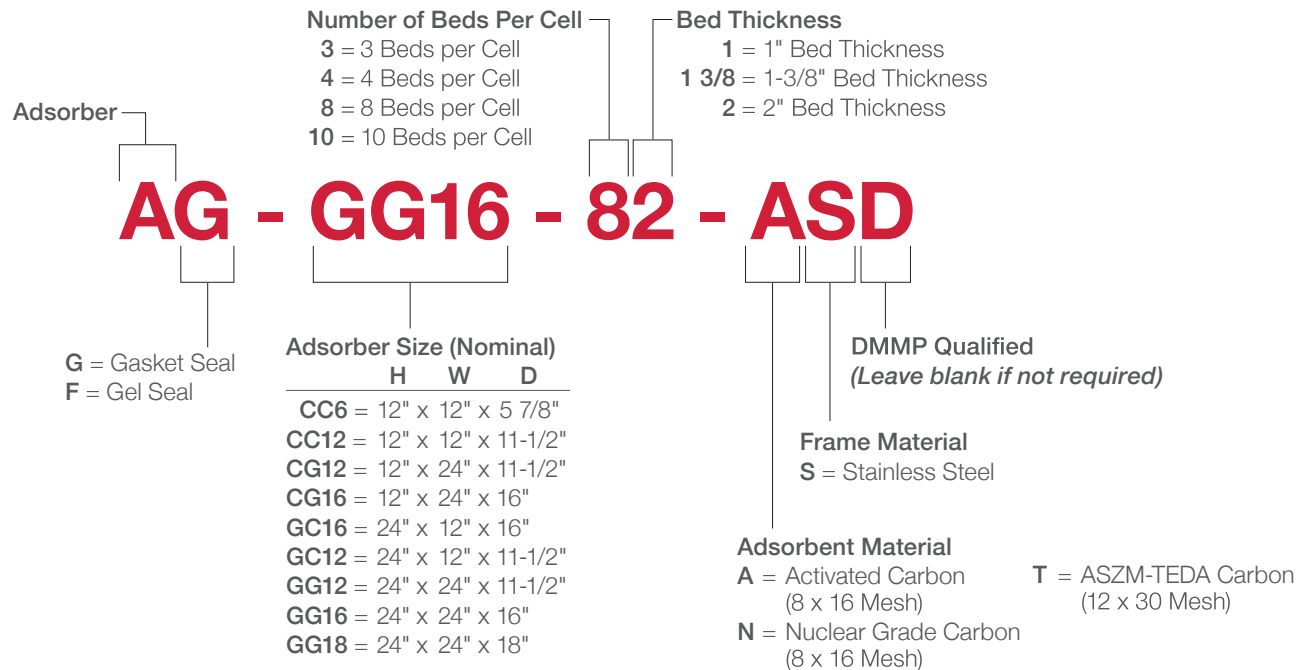

Notes:

- In the charts on the following pages, pressure drop and weight will vary slightly due to variations in carbon particle size distribution and packing density.
- Not all model number combinations above are available.

AAF HEGA Filters: Ordering Information

Ordering Information: Type IV (V-Bed) Stainless Steel Adsorber

Note: ΔP may vary by +/- 20% due to physical characteristics of the carbon. These variations must be considered when sizing fans.

Full Size Gel Seal Adsorbers

Model Number	Size H x W x D w/ Gel Seal Channel (Inches)	Rated Flow (CFM)	Approx. ΔP (In. W.G.)	Res. Time (Sec.)	No. of Beds	Bed Depth (Inches)	Max Temp.	Approx. Carbon Net Wt. (Lbs.)	Approx. Ship Wt. (Lbs.)
AF-GC12-101-AS	24x12x12-1/4	500	0.90	0.083	10	1	200°F	29	92
AF-GC12-101-NS	24x12x12-1/4	500	0.90	0.083	10	1	200°F	32	95
AF-GC12-101-TS	24x12x12-1/4	500	2.00	0.083	10	1	200°F	35	98
AF-GG12-101-AS	24x24x12-1/4	1000	0.90	0.083	10	1	200°F	58	153
AF-GG12-101-NS	24x24x12-1/4	1000	0.90	0.083	10	1	200°F	64	159
AF-GG12-101-TS	24x24x12-1/4	1000	2.00	0.083	10	1	200°F	70	165
AF-GG16-81-3/8-AS	24x24x16-3/4	1000	0.85	0.125	8	1-3/8	200°F	75	210
AF-GG16-81-3/8-NS	24x24x16-3/4	1000	0.85	0.125	8	1-3/8	200°F	80	215
AF-GG16-81-3/8-TS	24x24x16-3/4	1000	2.10	0.125	8	1-3/8	200°F	90	225
AF-GG12-62-AS	24x24x12-1/4	700	1.75	0.125	6	2	200°F	59	162
AF-GG12-62-NS	24x24x12-1/4	700	1.75	0.125	6	2	200°F	62	165
AF-GG12-62-TS	24x24x12-1/4	700	3.90	0.125	6	2	200°F	70	173
AF-GG16-62-AS	24x24x16-3/4	1000	1.75	0.125	6	2	200°F	79	205
AF-GG16-62-NS	24x24x16-3/4	1000	1.75	0.125	6	2	200°F	86	212
AF-GG16-62-TS	24x24x16-3/4	1000	3.90	0.125	6	2	200°F	98	224
AF-GG16-62-TSD	24x24x16-3/4	1000	3.90	0.125	6	2	200°F	100	226
AF-GG18-62-AS	24x24x18-3/4	1250	1.75	0.125	6	2	200°F	90	225
AF-GG18-62-NS	24x24x18-3/4	1250	1.75	0.125	6	2	200°F	96	231
AF-GG18-62-TS	24x24x18-3/4	1250	4.10	0.125	6	2	200°F	105	240

Ordering Information: Type IV (V-Bed) Stainless Steel Adsorber- Small Size Adsorbers

Ordering information below is for small size gel and gasket seal adsorbers, grouped by adsorbent materials (Activated Carbon, Nuclear Grade Carbon, and ASZM-TEDA Carbon).

Note: ΔP may vary by +/- 20% due to physical characteristics of the carbon. These variations must be considered when sizing fans.



Small Size Stainless Steel Gel Seal Adsorbers - Activated Carbon

Model Number	Size H x W x D w/ Gel Seal Channel (Inches)	Rated Flow (CFM)	Approx. ΔP (In. W.G.)	Res. Time (Sec.)	No. of Beds	Bed Depth (Inches)	Max Temp.	Approx. Carbon Net Wt. (Lbs.)	Approx. Ship Wt. (Lbs.)
AF-BB6-41-AS	8x8x6-5/8	40	0.45	0.083	4	1	200°F	3	16
AF-CC6-41-3/8-AS	12x12x 6-5/8	55	0.90	0.125	4	1-3/8	200°F	8	33
AF-CC12-41-3/8-AS	12x12x12-1/4	140	1.10	0.125	4	1-3/8	200°F	14	53
AF-CC16-41-3/8-AS	12x12x16-3/4	465	0.85	0.125	4	1-3/8	200°F	45	124

Small Size Stainless Steel Gasket Seal Adsorbers - Activated Carbon

Model Number	Size H x W x D w/ Gel Seal Channel (Inches)	Rated Flow (CFM)	Approx. ΔP (In. W.G.)	Res. Time (Sec.)	No. of Beds	Bed Depth (Inches)	Max Temp.	Approx. Carbon Net Wt. (Lbs.)	Approx. Ship Wt. (Lbs.)
AG-BB6-41-AS	8x8x5-7/8	40	0.45	0.083	4	1	200°F	3	15
AG-CC6-41-3/8-AS	12x12x 5-7/8	55	0.90	0.125	4	1-3/8	200°F	8	31
AG-CC12-41-3/8-AS	12x12x11-1/2	140	1.10	0.125	4	1-3/8	200°F	14	31
AG-CC16-41-3/8-AS	12x24x16	465	0.85	0.125	4	1-3/8	200°F	45	121

AAF HEGA Filters: Ordering Information

Ordering Information: Type IV (V-Bed) Stainless Steel Adsorber- Small Size Adsorbers (continued)

Small Size Stainless Steel Gel Seal Adsorbers - Nuclear Grade Carbon									
Model Number	Size H x W x D w/ Gel Seal Channel (Inches)	Rated Flow (CFM)	Approx. ΔP (In. W.G.)	Res. Time (Sec.)	No. of Beds	Bed Depth (Inches)	Max Temp.	Approx. Carbon Net Wt. (Lbs.)	Approx. Ship Wt. (Lbs.)
AF-BB6-41-NS	8x8x6-5/8	40	0.45	0.083	4	1	200°F	3	16
AF-CC6-41-3/8-NS	12x12x 6-5/8	55	0.90	0.125	4	1-3/8	200°F	8	33
AF-CC12-41-3/8-NS	12x12x12-1/4	140	1.10	0.125	4	1-3/8	200°F	15	54
AF-CC16-41-3/8-NS	12x12x16-3/4	465	0.85	0.125	4	1-3/8	200°F	48	127

Small Size Stainless Steel Gasket Seal Adsorbers - Nuclear Grade Carbon									
Model Number	Size H x W x D w/ Gel Seal Channel (Inches)	Rated Flow (CFM)	Approx. ΔP (In. W.G.)	Res. Time (Sec.)	No. of Beds	Bed Depth (Inches)	Max Temp.	Approx. Carbon Net Wt. (Lbs.)	Approx. Ship Wt. (Lbs.)
AG-BB6-41-NS	8x8x5-7/8	40	0.45	0.083	4	1	200°F	3	16
AG-CC6-41-3/8-NS	12x12x 5-7/8	55	0.90	0.125	4	1-3/8	200°F	8	31
AG-CC12-41-3/8-NS	12x12x11-1/2	140	1.10	0.125	4	1-3/8	200°F	15	52
AG-CC16-41-3/8-NS	12x12x16	465	0.85	0.125	4	1-3/8	200°F	48	124

AAF HEGA Filters: Cinersorb

Cinersorb: Incinerable High-Efficiency Gas Adsorber

The Cinersorb is the solution to problems associated with the disposal of carbon adsorbers contaminated with toxic, carcinogenic, microbiological, radioactive, or other dangerous contaminants.

Many facilities have a waste disposal problem regarding high-efficiency adsorbers that are loaded with dangerous contaminants. In the past, high-efficiency adsorbers (i.e., adsorbers that exhibit a mechanical efficiency of 99.9%) have been manufactured with metal frames. Since these metal frame adsorbers cannot always be safely refilled with fresh carbon, their disposal becomes a problem.

The AAF Cinersorb, which has a combustible frame constructed of high-impact polystyrene plastic, solves this problem.

Incineration guidelines vary from contaminant to contaminant. The customer should determine that incineration meets the requirements governed by type of contaminant in question and local regulations.

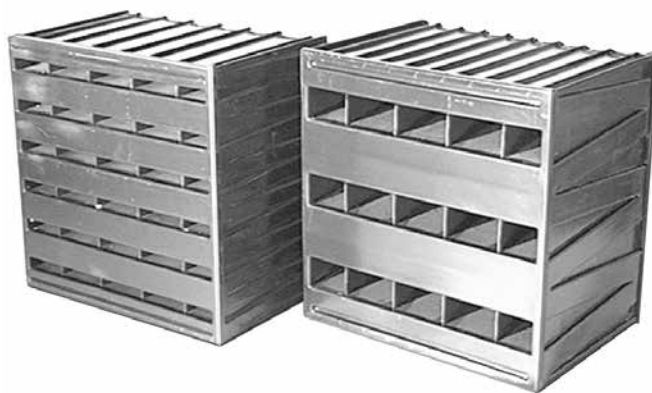

Features

- Polystyrene frame allows disposal by incineration (volume reduction exceeds 95%)
- Mechanical efficiency of 99.9% when tested in accordance with IES-RP-CC-008-84, "Recommended Practice for Gas-Phase Adsorber Cells"
- Available in many sizes (See pp. 15-16), allowing use in most standard filter housings
- Easier to handle, weighs 40-50% less than metal frame adsorbers
- Less expensive than metal frame adsorbers
- Corrosion resistant
- Can be filled with any adsorbent to capture almost any contaminant
- Many applications, including safety cabinet, glove box, and fume hood exhaust; laboratory supply air; and odor control
- Designed, manufactured, and tested under a Quality Assurance Program that meets the requirements of ASME-NQA-1, "Quality Assurance Program for Nuclear Facilities"

AAF HEGA Filters: Suggested Specifications Cinersorb Disposable Carbon Adsorbers

From the tables on Pages 15 - 16, fill in the blanks for adsorber requirements.

Adsorber shall be AAF model number _____.

Adsorber frame shall be constructed of high-impact polystyrene to allow disposal of spent adsorber by incineration. Adsorbers shall have _____ beds that are _____ deep, arranged in a V-bank configuration.

The filter frame shall be size: _____" high x _____" wide x _____" deep, and have _____ (gel/gasket) seal on one side.

The rated flow shall be _____ CFM at _____" w.g. pressure drop and _____ -second residence time.

Adsorber screens shall be perforated plastic supported by external spacers to prevent distortion during filling with carbon. Adsorber shall exhibit a minimum mechanical efficiency of 99.9% when tested in accordance with IES-RP-CC-008-84, "Recommended Practice for Gas-Phase Adsorber Cells."

Model Number Breakdown (Example)

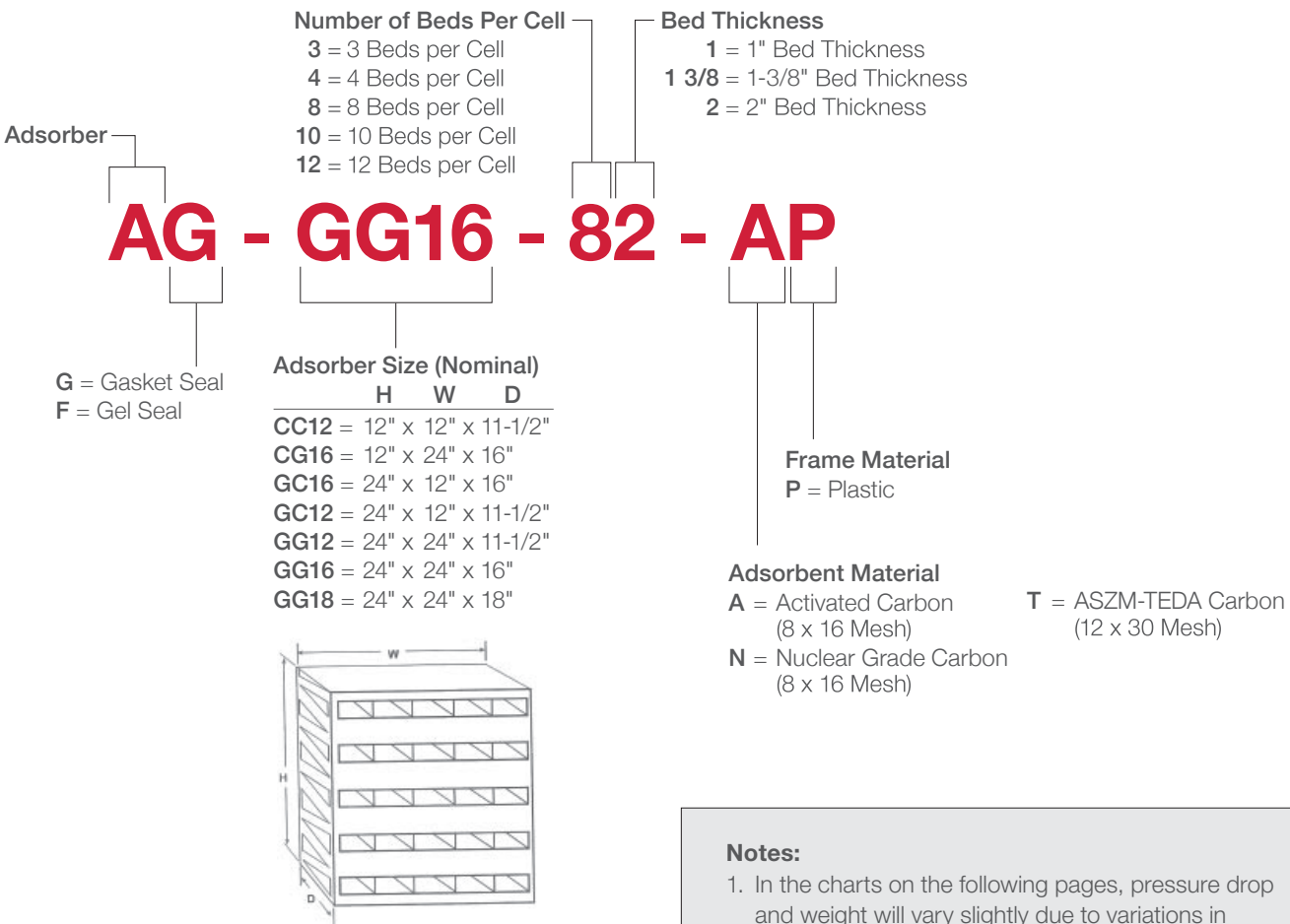

Notes:

- In the charts on the following pages, pressure drop and weight will vary slightly due to variations in carbon particle size distribution and packing density.
- Not all model number combinations above are available.

AAF HEGA Filters: Ordering Information

Ordering Information: Cinersorb Disposable Carbon Adsorber

These adsorbers are designed as disposable units. DO NOT refill with fresh carbon for reuse. NOT recommended for use in systems above 120° F, or in which contaminants will attack the polystyrene plastic frame material.

Note: ΔP may vary by +/- 20% due to physical characteristics of the carbon. These variations must be considered when sizing fans.

Gel Seal Housings									
Model Number	Size H x W x D w/ Gel Seal Channel (Inches)	Rated Flow (CFM)	Approx. ΔP (In. W.G.)	Res. Time (Sec.)	No. of Beds	Bed Depth (Inches)	Max Temp.	Approx. Carbon Net Wt. (Lbs.)	Approx. Ship Wt. (Lbs.)
AF-GC12-101-AP	24x12x12-1/4	500	0.90	0.083	10	1	120°F	23	92
AF-GC12-101-NP	24x12x12-1/4	500	0.90	0.083	10	1	120°F	25	95
AF-GC12-101-TP	24x12x12-1/4	500	2.00	0.083	10	1	120°F	26	98
AF-GG12-101-AP	24x24x12-1/4	1000	0.90	0.083	10	1	120°F	43	153
AF-GG12-101-NP	24x24x12-1/4	1000	0.90	0.083	10	1	120°F	49	159
AF-GG12-101-TP	24x24x12-1/4	1000	2.00	0.083	10	1	120°F	52	165
AF-GG12-62-AP	24x24x12-1/4	700	1.75	0.125	6	2	200°F	59	162
AF-GG12-62-NP	24x24x12-1/4	700	1.75	0.125	6	2	200°F	59	162
AF-GG16-81-3/8-AP	24x24x16-3/4	1000	0.85	0.125	8	1-3/8	120°F	74	113
AF-GG16-81-3/8-NP	24x24x16-3/4	1000	0.85	0.125	8	1-3/8	120°F	79	118
AF-GG16-81-3/8-TP	24x24x16-3/4	1000	2.10	0.125	8	1-3/8	120°F	88	127
AF-GG16-121-AP	24x24x16-3/4	1000	0.5	0.125	12	1	120°F	78	120
AF-GG16-121-NP	24x24x16-3/4	1000	0.5	0.125	12	1	120°F	78	120
AF-GG16-62-AP	24x24x16-3/4	1000	1.75	0.125	6	2	120°F	80	115
AF-GG16-62-NP	24x24x16-3/4	1000	1.75	0.125	6	2	120°F	84	119
AF-GG16-62-TP	24x24x16-3/4	1000	3.90	0.125	6	2	120°F	96	131
AF-GG18-62-AP	24x24x18-3/4	1250	1.75	0.125	6	2	120°F	79	127
AF-GG18-62-NP	24x24x18-3/4	1250	1.75	0.125	6	2	120°F	86	131
AF-GG18-62-TP	24x24x18-3/4	1250	4.10	0.125	6	2	120°F	100	140

AAF HEGA Filters: Ordering Information

Ordering Information: Cinersorb Disposable Carbon Adsorber (continued)

Note: ΔP may vary by +/- 20% due to physical characteristics of the carbon. These variations must be considered when sizing fans.

Gasket Seal Housings

Model Number	Size H x W x D w/ Gel Seal Channel (Inches)	Rated Flow (CFM)	Approx. ΔP (In. W.G.)	Res. Time (Sec.)	No. of Beds	Bed Depth (Inches)	Max Temp.	Approx. Carbon Net Wt. (Lbs.)	Approx. Ship Wt. (Lbs.)
AG-GC12-101-AP	24x12x12-1/4	500	0.90	0.083	10	1	120°F	23	42
AG-GC12-101-NP	24x12x12-1/4	500	0.90	0.083	10	1	120°F	25	44
AG-GC12-101-TP	24x12x12-1/4	500	2.00	0.083	10	1	120°F	26	45
AG-GG12-101-AP	24x24x12-1/4	1000	0.90	0.083	10	1	120°F	43	77
AG-GG12-101-NP	24x24x12-1/4	1000	0.90	0.083	10	1	120°F	49	83
AG-GG12-101-TP	24x24x12-1/4	1000	2.00	0.083	10	1	120°F	52	86
AG-GG12-62-AP	24x24x12-1/4	700	1.75	0.125	6	2	200°F	59	162
AG-GG12-62-NP	24x24x12-1/4	700	1.75	0.125	6	2	200°F	59	162
AG-GG16-81-3/8-AP	24x24x16-3/4	1000	0.85	0.125	8	1-3/8	120°F	74	113
AG-GG16-81-3/8-NP	24x24x16-3/4	1000	0.85	0.125	8	1-3/8	120°F	79	118
AG-GG16-81-3/8-TP	24x24x16-3/4	1000	2.10	0.125	8	1-3/8	120°F	88	127
AG-GG16-121-AP	24x24x16-3/4	1000	0.5	0.125	12	1	120°F	78	120
AG-GG16-121-NP	24x24x16-3/4	1000	0.5	0.125	12	1	120°F	78	120
AG-GG16-62-AP	24x24x16-3/4	1000	1.75	0.125	6	2	120°F	80	115
AG-GG16-62-NP	24x24x16-3/4	1000	1.75	0.125	6	2	120°F	84	119
AG-GG16-62-TP	24x24x16-3/4	1000	3.90	0.125	6	2	120°F	96	131
AG-GG18-62-AP	24x24x18-3/4	1250	1.75	0.125	6	2	120°F	79	127
AG-GG18-62-NP	24x24x18-3/4	1250	1.75	0.125	6	2	120°F	86	131
AG-GG18-62-TP	24x24x18-3/4	1250	4.10	0.125	6	2	120°F	100	140

AAF HEGA Filters: Carbon Sampling Systems

Carbon Sampling Canisters

In nuclear applications, *US Reg. Guide 1.52 details the frequency of having carbon tested for ability to remove methyl iodide. The sampler devices shown simplify the sample-taking procedure. The sampler is removed, the sampler space is blanked off, and the sample is sent to the lab for analysis. No in-place test is required.

Existing systems can use the compatible AAF sampling system for easy conversion.

Note: If a filter is removed to provide a sample, an in-place test must be performed after the filter is replaced.



Carbon Sampler Blank Off Plug and Canister/Plug Removal Tool (furnished)

Radioactive Iodine Performance Test

AAF can provide radioiodine testing services on samples of carbon to determine if the samples meet customer specifications. Tests can be expedited to prevent extended downtime of the customer's air filtration system. Tests are performed to latest versions of ASTM-D3803, ASME N509, and ASME AG-1, but any standard radioiodine testing can be performed. Customer can also specify custom test parameters, if required.

Types of Adsorption

There are three types of adsorption that concern us:

1. Kinetic
2. Isotopic Exchange
3. Chemisorption

Kinetic: Kinetic adsorption of a gas molecule or chemical vapor is the physical attraction of the molecule to the carbon granule by electrostatic forces. These forces, as they apply to small particles, are governed by van der Waals' theories, and these attraction forces are termed van der Waals' forces. Since these forces are physical in nature, the forces can be undone by physical effort. Thus, high temperature, high humidity, or other natural causes may cause an adsorbed contaminant to desorb.

Generally, the higher the boiling point, the larger the molecule size, and the lower the melting temperature, the easier the molecule is to kinetically adsorb, and the stronger it is held once it is adsorbed.

Isotopic Exchange: A second "adsorption" mechanism is isotopic exchange. Radioactive materials usually have a family of isotopes. If a stable isotope is adsorbed on the carbon initially, an unstable isotopic compound will, when it comes into contact with the stable form of the element, exchange the isotopes. The stable form is now on the airborne molecule, and the radioactive form is on the molecular structure of the impregnant. An example of this is carbon impregnated with KI3. The radioactive form of iodine in the organic form $\text{CH}_3\text{I}-131$ will isotopically exchange with the iodine on the carbon. This exchange is non directional, meaning the adsorbed (exchanged) radioactive species of iodine may very well exchange again. The result will be a different airborne radioactive methyl iodide molecule. This new radioactive molecule may again isotopically exchange with stable iodides on the carbon in the KI3 impregnant, and so on, until the radioactive iodine is delayed long enough to decay into stable xenon.

AAF HEGA Filters: Carbon Sampling Systems

Types of Adsorption (continued)

Chemisorption: A third capture mechanism is chemisorption. This is the chemical attachment of a radioactive iodine species to a stable impregnant that has the ability to share electrons. Once the iodine is complexed, it does NOT desorb similarly to isotopic exchange. An example of this is to impregnate the carbon with triethylenediamine (TEDA) or some other tertiary amine.

To take advantage of both impregnants and capture mechanisms, carbon can be co-impregnated. This allows the carbon to be used as a kinetic adsorber, an isotopic exchange medium, and a chemisorption agent. As long as the operating conditions are kept within normal bounds, the carbon will perform as required. It will perform under high-humidity conditions and under high-temperature conditions better than a carbon with a single impregnant.

Efficiency vs. Penetration

There is often confusion between “efficiency” and “penetration” of contaminants through a carbon bed.

Efficiency is the ability for the carbon to remove a desired contaminant. Methyl iodide efficiency, for example, is determined by challenging the carbon with an actual radioactive methyl iodide vapor. The amount of the contaminant upstream of the carbon is known, and the amount that is collected on backup beds is measured. The efficiency of that carbon sample to remove methyl iodide is easily calculated by comparing the counts of the carbon sample to the counts on the backup beds. Test parameters such as temperature and relative humidity greatly affect the efficiency.

Penetration, on the other hand, is a term used to indicate the degree of leak tightness for installed carbon systems. The installed system is subjected to a test gas that is easily adsorbed, such as R-11 (trichlorofluoromethane). The penetration, or by-pass of the R-11, is measured downstream of the filter, and that amount is compared to the amount measured upstream of the filter. A penetration value in percent is easily calculated from the collected data. This is also termed mechanical efficiency.

Residence Time

Chemisorption: Residence time is the term given to the time that a gas stream contacts a carbon bed. For example, if a carbon bed were a foot thick, and the air stream moved at one foot per minute, the residence time would be one minute. It would take one minute for the air to move through the bed.

Typically, the carbon bed is 1 inch thick and the air velocity is 40 feet per minute. What would the residence time be in that situation? (0.125 seconds) The residence time can be calculated easily from the following relationships:

$$RT = 5 \times \frac{D}{V}$$

Where:

RT = Residence time (seconds)

D = Depth of carbon bed (inches)

V = Velocity of gas through bed (feet/min.)

Most of the time, the velocity will not be given and must be calculated from the relationship:

$$V = \frac{Q}{A}$$

Where:

V = Velocity of gas through bed (feet/min.)

A = Unbaffled area of carbon bed (sq. ft.)

Q = Quantity of gas flowing through bed (CFM)

Let's take an example from real life: Assume that Q=1,000 CFM and that a single 6-panel, 16-inch deep (in direction of air flow), 2-inch bed depth filter is to be used. To calculate the residence time, first determine the area of the carbon bed. The total area is 12.5 sq. ft. The 12.5 sq. ft. is determined by actual measurements of the unbaffled bed area on one side of the carbon filter. Therefore:

$$V = \frac{Q}{A}$$

$$V = \frac{1000 \text{ CFM}}{12.5 \text{ ft.}}$$

$$V = 80 \text{ ft./min.}$$

And:

$$RT = 5 \times \frac{D}{V}$$

$$RT = \frac{5 \times 2}{80}$$

$$RT = \frac{10}{80}$$

$$RT = 0.125 \text{ second}$$

Residence Time (continued)

The concept of residence time is very important from the designer's point of view. That is why AAF is taking a lot of time to explain it fully. AAF cannot design a system unless we know either the actual residence time required, or all of the parameters that determine the optimum residence time (flow rate, contaminants, concentrations, temperature, humidity, required efficiency, etc.)

The residence time is critical to the chemisorption or complexing phenomena. As the gas enters the bed, it must have time to interact with the impregnants on the carbon. Too little time will mean that the contaminants will not interact completely with the carbon or impregnants. Too much time means that the system is not designed efficiently.

In summary, you need to be aware of the important of residence time because the first question we ask about an inquiry for any carbon system is, "What is the residence time requirement?" Without this information, our engineering staff cannot design the best system for your application

Capacity

The capacity of activated carbon is the percentage of its own weight that an activated carbon can adsorb of a given vapor under certain conditions. Some of these conditions are vapor concentration, temperature, humidity, air velocity, and defined breakthrough.

Example: If 100 pounds of activated carbon adsorbs 15 pounds of benzene before it reaches a customer-defined breakthrough point of 5 ppm, then the capacity of that activated carbon for benzene is 15%.

Decontamination Factor

The Decontamination Factor is the ratio of the concentration of a contaminant in the untreated air to the concentration of the contaminant in the treated air.

If anyone asks what the Decontamination Factor (DF) of a filter is, the answer can be obtained by calculating the RECIPROCAL of the penetration expressed as a fraction, or

$$DF = \frac{1}{\text{Pen.}}$$

Example

Penetration	Calculation	Result
40%	$DF = \frac{1}{0.40}$	DF = 2.5
0.1%	$DF = \frac{1}{0.001}$	DF = 1,000
5%	$DF = \frac{1}{0.05}$	DF = 20

Design Principles for Filtering Dangerous Chemical Contaminants

It is generally acknowledged that a properly designed filtration system for the removal of dangerous chemical contaminants should be as follows:

1. HEPA filters should be used to trap dangerous particulates and protect the carbon filters from collecting particulates, thereby increasing the adsorber's pressure drop.
2. Carbon filters must:
 - a. Exhibit a minimum mechanical efficiency of 99.9% (i.e., HEGA).
 - b. Use high-quality coconut shell activated carbon.
 - c. Be sized for approximately 0.125-second residence time.
3. All filters should be installed in "Bag-in/Bag-out" housings to protect maintenance personnel and the environment.
4. Filtration system designs should have provisions for pulling samples of air or carbon for laboratory analysis (to assist in determining when carbon adsorbers need changing).
5. The disposal of hazardous waste (i.e., spent HEPA and HEGA filters) should also be considered. Any HEPA or HEGA filter containing regulated chemicals should be disposed of in accordance with federal, state, and local restrictions.
6. The filtration system must be manufactured under a quality control program that addresses the requirements of ASME NQA-1, "Quality Assurance Program Requirements for Nuclear Facilities."

General Information on Carbon and Adsorption Materials

The following are thoughts and information that will help you form a general idea about carbon filter technology. These comments are to be considered as general axioms, and the reader should be able to “fill in” some of the unknown factors when unusual situations arise. However, there is no substitute for expert advice and opinion, and the reader is urged to contact AAF Flanders for answers to any technical problem, specific questions, or additional information.

1. Elemental iodine is adsorbed by attraction of the iodine to the carbon. This is called kinetic adsorption.
2. Methyl iodide, which comes from elemental iodine (I_2) combining with methane, must be adsorbed by chemisorption, usually in the form of isotopic exchange when KI carbon is used or chemisorption when TEDA carbon is used.
3. The recommended residence time for methyl iodide is 0.25 seconds residence time per 2-inch bed. Tests have shown that the carbon will perform as required at twice that velocity or half that residence time for a limited time period.
4. As the humidity increases, the ability of the carbon to the performance of the carbon is adversely affected. However, the carbon must perform at 95% relative humidity in order to meet ASME AG-1 requirements.
5. The heavier the molecular weight of a material, the easier it is to adsorb.
6. The higher the boiling temperature of a material, the easier it is to adsorb.
7. The converse of 5 and 6 is true.
8. One gram of 60% active carbon (as measured by carbon tetrachloride) has a surface area of about 1,000 square meters.
9. The adsorption coefficient of carbon is the amount of a given material that the carbon will adsorb by weight.
10. Some hard-to-adsorb materials can be displaced by easier-to-adsorb materials. For example, acetic anhydride may displace acetone. Acetone may displace acetaldehyde, and acetaldehyde may displace acetylene.
11. The lower the concentration of a material, the harder to achieve a high removal percentage.
12. One gram of carbon will adsorb one milligram of iodine. The potential inventory of radioiodine in a nuclear power system is very small.
13. Since carbon will adsorb anything adsorbable, it can be *poisoned* by harmless materials and rendered unable to adsorb the material that it was designed to control. That is why the carbon should always be protected from vapors that will harm it.
14. Shelf life of carbon in properly packaged drums or in filters having a vapor barrier of some kind can be as long as five (5) years. AAF Flanders recommends that carbon over three (3) years old be retested to ensure that it meets the efficiency requirements of the original specifications.
15. Methyl iodide adsorbs-desorbs-adsorbs through the bed, exchanging iodine at each juncture. That is to say, methyl iodide can be radioactive-stable-radio-active-stable until it decays into harm-less xenon.
16. Elemental iodine, once adsorbed, usually stays adsorbed.

AAF HEGA User Guide: Handling /Unpacking, Storage, and Operating Conditions

Background

AAF Flanders High Efficiency Gas Adsorbers (HEGA) are sensitive, high purity elements and should be handled and installed using proper and attentive techniques. Special care must be taken in the selection of a carrier for transport, and in the training of installation and facilities personnel.

Receiving/Handling Procedures

1. Carefully check each pallet of adsorbers before accepting shipment from the carrier. Pallets of adsorbers that have been damaged or broken down should not be accepted without a thorough inspection and appropriate comments noted on the shipping documentation.
2. Pallets of adsorbers or individual adsorbers should never be subjected to excessive shock, vibration, or extreme temperatures. The shock caused by dropping an adsorber can cause serious damage.
3. Pallets of adsorbers should not be stacked.



To remove the adsorber(s) from the carton(s), follow these steps:

Individually Packaged

1. Carefully open the top of the box.
2. If the adsorbers come packaged with suitcase-style cardboard sleeves, simply reach into the box and grab the handles.

If the adsorber is in a cardboard liner, the adsorber must be oriented so that the open ends of the liner are facing outward (i.e., to your left and right rather than upward). Carefully cut the packing tape that holds the adsorber in the liner. Always check for torn or deflected liner edges. If any are found, straighten or flatten such edges prior to liner removal to prevent damage.

One person should carefully hold the plastic bag(s) while the other person carefully pulls the liner, sliding it away from the adsorber. Remove adsorbers without liners or sleeves by carefully inverting the carton 180° with the carton flaps flush against a clean floor. Slowly pull up on the carton until the carton has cleared the adsorber.

3. The adsorber should now be handled with extreme care to prevent damage to the face screens and sealing surfaces. While the bag is still present, carry the adsorber in the bag. Be careful to keep the adsorber away from any objects in your path. If the bag is not present, always handle the adsorber from the frame, avoiding contact with the media and the face screen. Adsorbers should always be transported vertically (face perpendicular to the floor) to help keep the chemical media from shifting and abrading.
4. Additional precautions for gel seal adsorbers: Care is taken at the factory to prevent the bag from contacting the gel. Be very careful when unpacking gel seal adsorbers to remove the bag slowly and carefully. If the bag comes in contact with the gel, pull the bag off the gel slowly. Quick removal of the bag may cause damage to the gel and possible separation of gel from the gel channel.

Note: It is recommended that adsorber handling be carried out by two people.

Bulk Packaged (multiple adsorbers in a single carton)

1. Carefully lift and remove top of the carton.
2. To remove adsorbers from the carton:
 - a) Each person should carefully insert one hand into the top of the protective liner.
 - b) Gently lift the adsorber out of the carton by the liner.
 - c) Care must be taken during this process, since the remaining adsorbers in the carton tend to tip within the carton. Position the remaining adsorbers to prevent tipping.
3. After the adsorber has been removed from the carton, the adsorber must be oriented so that the open ends of the liner are pointing upward. Carefully cut the packing tape that holds the adsorber in the liner. Always check for torn or dented liner edges. If any are found, straighten or flatten such edges prior to liner removal to prevent damage. One person should carefully hold the plastic bag(s) while the other person carefully pulls the liner, sliding it away from the liner.
4. The adsorber should now be handled with extreme care to prevent damage to the face screens and sealing surfaces. While the bag is still present, carry the adsorber in the bag. Be careful to keep the adsorber away from any objects in your path. If the bag is not present, always handle the adsorber from the frame, avoiding contact with the media and the face screen. Adsorbers should always be transported vertically (face perpendicular to the floor) to help keep the chemical media from shifting and abrading.
5. Remove the bag carefully.
6. Additional precautions for gel seal adsorbers: Care is taken at the factory to prevent the bag from contacting the gel. Be very careful when unpacking gel seal adsorbers by removing the bag slowly and carefully. If the bag comes in contact with the gel, pull the bag off the gel slowly. Quick removal of the bag may cause damage to the gel and possible separation of gel from the gel channel.

Guidelines for Storing, Operating and Installing

AAF HEGA Adsorbers

1. Storage
 - a) Location: Adsorbers should be stored in their original cartons in a climate-controlled environment, protected from inclement weather.
 - b) Temperature Limits: Maximum temperatures of 125°F (38°C). Minimum temperature is -4°F (-20°C).
 - c) Adsorbers should be oriented with media beds horizontal to the ground and stacked no more than two cartons (or over 5 ft.) high, unless intermediate bracing or flooring is provided to prevent the weight of the upper tier from bearing on the lower tier.
 - d) Unless there is obvious damage to the cartons, adsorbers should not be opened prior to use, nor removed from shipping pallets or skids until immediately prior to installation.
 - e) Adsorbers should not be exposed to ultraviolet (UV) rays, ozone-depleting sources and or contaminated environments prior to use.
 - f) If the above storage requirements are met, adsorbers should have a shelf life of three (3) years from gasket cure date or three (3) years from manufacturing date for fluid seal filters.
2. Operating Conditions
 - a) Temperature: The maximum operating temperature is determined by the adsorber configuration. Consult the adsorber submittal drawing for the specific maximum operating temperature.
 - b) Humidity: 99% relative humidity, non-condensing is acceptable. However, condensation must be avoided to prevent degradation of performance and potential media failure.
 - c) Adsorbers should not be operated in any environment they were not specifically designed to operate in.
 - d) Adsorbers should not be operated in excess of the rated flow rate. In case of elevated airflows, contact the factory.
3. Installation
 - a) Adsorbers should be installed with the media beds parallel to the ground, with horizontal airflow.
 - b) Do not allow any solid object (e.g., hands, tools, etc.) to come in contact with the media or the media screens during or after installation. Failure to prevent contact can damage the adsorber. Be sure to handle the adsorber only by its frame.

Important Notice

For best results in the application of AAF products, it is recommended that the buyer supply complete information about the operating conditions of the ventilation system to AAF for prior evaluation.

AAF does not guarantee that its equipment will operate at the performance levels given on the identification labels, or in the catalog specifications under all conditions of installation and use, nor does AAF guarantee that suitability of its product for the particular end use that may be contemplated by the buyer. When the system components are supplied to the buyer or an agent for final installation and assembly in the field, it should be under the supervision of factory-trained personnel who are equipped to test the installation and certify its performance and conformance to industry-accepted specifications. Failure to follow these procedures may result in a compromised installation.



9920 Corporate Campus Drive, Suite 2200, Louisville, KY 40223-5690
888.223.2003 Fax 888.223.6500 | aafintl.com

AAF has a policy of continuous product research and improvement. We reserve the right to change design and specifications without notice.

©2023 AAF International and its affiliated companies.

ISO Certified Firm

CSP-3-108E 1/23