

SureSeal™

(Two-Stage Prefilter & Secondary)

SIDE ACCESS FILTER HOUSINGS

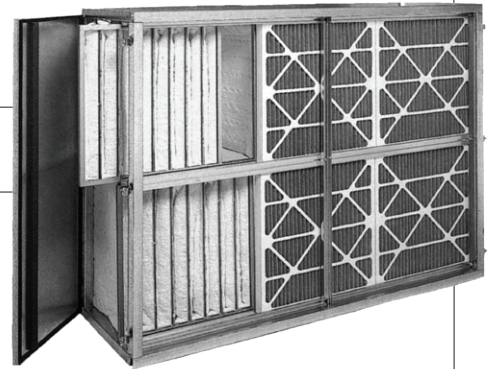

- Units are constructed of durable 16-gauge galvanized steel
- “Z” channel support members reinforce all four corners
- All tracks and doors are fully gasketed
- Holding frames or fasteners are not required

Options

- Double-walled insulation on doors only or on entire housing
- Flanges to connect with air handlers
- 4" thick prefilter track
- Aluminum or 304 stainless steel construction

SureSeal side access filter housings are two-stage units designed to accommodate ASHRAE rated filters that are 6" to 36" in depth. They are factory assembled flanged units suitable for installation in a duct or attached to an air handling unit. As little as 22" of inline depth is required, with no need for holding frames or fasteners.

SureSeal housings accommodate prefilters and primary filters of different types and efficiencies. Filters are easily serviced through quick-opening access doors. Factory-gasketed filters, channels, and doors ensure positive sealing. The efficiency of fully-loaded housings is equal to that of the individual filters. The recommended system static pressure range for standard housings is -4.0 in. w.g. to +3.0 in. w.g. The leakage rate is less than 0.5% of airflow at 6.0" w.g. internal static pressure.

Versatility

SureSeal housings include 2" prefilter tracks for AAF's pleated or fiberglass filters. SureSeal units are available in sizes up to 8 feet high and 12 feet wide. If large units are not practical to install, smaller units are available with modifications to facilitate stacking.

Construction

Housings are constructed of 16-gauge galvanized steel with upstream and downstream outwardly-turned flanges. Units wider than 4 feet include intermediate support channels. Filter tracks are extruded aluminum. The primary track accepts nominal 1" thick filter headers, and the prefilter track accepts 2" or 4" thick panel filters. Both tracks are gasketed with replaceable polypropylene pile air seals.

Standard units are 22½" deep and are available with optional extensions to accommodate deeper filters. SureSeal housings can be manufactured to a maximum depth of 44". Doors are equipped with 1½" positive sealing knobs made of UV-resistant plastic with corrosion resistant brass inserts. Housings are equipped with two access doors that are sealed with neoprene gasketing on the perimeter. Gasketing also seals the filter edge to the door. Construction of the top pan allows rainwater to drain off so that additional weatherproofing is rarely required.

SureSeal™ Side Access Filter Housings

Performance Data

Height Code	Overall Flange Height (inches)	Face Velocity (FPM)	CFM Capacities and Dimensions										
			Width Code										
			10W	15W	20W	25W	30W	35W	40W	45W	50W	55W	60W
			Overall Flange Width										
			23 ³ / ₈	34 ³ / ₄	46 ³ / ₄	58 ¹ / ₈	70 ¹ / ₈	81 ¹ / ₂	93 ¹ / ₂	104 ⁷ / ₈	116 ⁷ / ₈	128 ¹ / ₄	140 ¹ / ₄
05H	15	375	750	–	1500	–	2250	–	3000	–	–	–	–
		500	1000	–	2000	–	3000	–	4000	–	–	–	–
		625	1250	–	2500	–	3750	–	5000	–	–	–	–
10H	27	375	1500	2250	3000	3750	4500	5250	6000	6750	7500	8250	9000
		500	2000	3000	4000	5000	6000	7000	8000	9000	10000	11000	12000
		625	2500	3750	5000	6250	7500	8750	10000	11250	12500	13750	15000
15H	39	375	2250	–	4500	–	6750	–	9000	–	11250	–	13500
		500	3000	–	6000	–	9000	–	12000	–	15000	–	18000
		625	3750	–	7500	–	11250	–	15000	–	18750	–	22500
20H	51	375	3000	4500	6000	7500	9000	10500	12000	13500	15000	16500	18000
		500	4000	6000	8000	10000	12000	14000	16000	18000	20000	22000	24000
		625	5000	7500	10000	12500	15000	17500	20000	22500	25000	27500	30000
25H	62 ¹ / ₂	375	3750	–	7500	–	11250	–	15000	–	25000	–	22500
		500	5000	–	10000	–	15000	–	20000	–	30000	–	30000
		625	6250	–	12500	–	18750	–	25000	–	31250	–	37500
30H	74 ¹ / ₂	375	4500	6750	9000	11250	13500	15750	18000	20250	22500	24750	27000
		500	6000	9000	12000	15000	18000	21000	24000	27000	30000	33000	36000
		625	7500	11250	15000	18750	22500	26250	30000	33750	37500	41250	45000
35H	86 ¹ / ₂	375	5250	–	10500	–	15750	–	21000	–	26250	–	31500
		500	7000	–	14000	–	21000	–	28000	–	35000	–	42000
		625	8750	–	17500	–	26350	–	35000	–	43750	–	52500
40H	98 ¹ / ₂	375	6000	9000	12000	15000	18000	21000	24000	27000	30000	33000	36000
		500	8000	12000	16000	20000	24000	28000	32000	36000	40000	44000	48000
		625	10000	15000	20000	25000	30000	35000	40000	45000	50000	55000	60000

Notes:

1. Height and width code: The first numeral represents the number of 24" x 24" filters high or wide. If 24" x 12" filters are also used in the height or width, the second numeral is "5".
2. Dimensions are based on using nominal size 24" x 24" and 24" x 12" filters.
3. For capacities other than those shown, ratio the face velocities.

Construction details

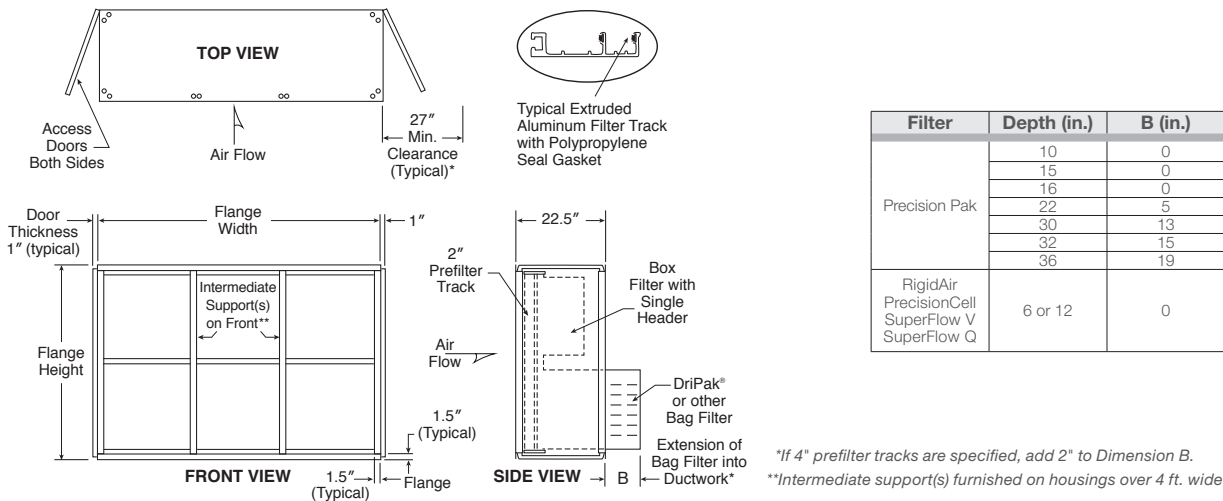

9920 Corporate Campus Drive, Suite 2200, Louisville, KY 40223-5690
888.223.2003 Fax 888.223.6500 | aafintl.com

AAF International has a policy of continuous product research and improvement. We reserve the right to change design and specifications without notice.

©2024 AAF International and its affiliated companies.

ISO Certified Firm

AFP-1-349A 06/24