

REVISIONS

A	REVISED INITIAL RESISTANCE		
	GAC 31MAY2024 - GC 03JUN2024 - SH 06JUN2024		

AAF PART NUMBER	NOMINAL SIZE inches			ACTUAL SIZE inches			POCKETS PER FILTER	GROSS MEDIA AREA (SQ. FT.)	FACE VELOCITY (FPM)	AIRFLOW (CFM)	INITIAL RESISTANCE (inch W.G.)	AAF PART NUMBER	NOMINAL SIZE inches			ACTUAL SIZE inches			POCKETS PER FILTER	GROSS MEDIA AREA (SQ. FT.)	FACE VELOCITY (FPM)	AIRFLOW (CFM)	INITIAL RESISTANCE (inch W.G.)
	A (WIDTH)	B (HEIGHT)	C (DEPTH)	A (WIDTH)	B (HEIGHT)	C (DEPTH)							A (WIDTH)	B (HEIGHT)	C (DEPTH)	A (WIDTH)	B (HEIGHT)	C (DEPTH)					
709-110-36X	24	24	36	23 5/16	23 5/16	36	10	130		2500	0.35	709-110-21X	24	24	21	23 5/16	23 5/16	21	10	75		2000	0.39
709-119-36X	24	24	36	23 5/16	23 5/16	36	9	117		2500	0.35	709-118-21X	24	24	21	23 5/16	23 5/16	21	8	60		2000	0.40
709-136-36X	20	24	36	19 5/16	23 5/16	36	6	78		2075	0.36	709-188-21X	24	20	21	23 5/16	19 5/16	21	8	53		1675	0.39
709-116-19X	24	24	19	23 5/16	23 5/16	19	6	41		2500	0.44	709-136-21X	20	24	21	19 5/16	23 5/16	21	6	45		1675	0.40
709-186-19X	24	20	19	23 5/16	19 5/16	19	6	37		2075	0.43	709-146-21X	20	20	21	19 5/16	19 5/16	21	6	40		1400	0.39
709-135-19X	20	24	19	19 5/16	23 5/16	19	5	34		2075	0.44	709-125-21X	12	24	21	11 5/16	23 5/16	21	5	37		1000	0.38
709-145-19X	20	20	19	19 5/16	19 5/16	19	5	30		1750	0.43	709-124-21X	12	24	21	11 5/16	23 5/16	21	4	30		1000	0.39
709-123-19X	12	24	19	11 5/16	23 5/16	19	3	21		1250	0.43	709-116-15X	24	24	15	23 5/16	23 5/16	15	8	43		2000	0.44
709-118-36X	24	24	36	23 5/16	23 5/16	36	8	104		2000	0.33	709-186-15X	24	20	15	23 5/16	19 5/16	15	6	29		1675	0.44
709-117-36X	24	24	36	23 5/16	23 5/16	36	7	91		2000	0.34	709-135-15X	20	24	15	19 5/16	11 5/16	15	5	27		1675	0.44
709-116-36X	24	24	36	23 5/16	23 5/16	36	6	78		2000	0.34	709-145-15X	20	20	15	19 5/16	19 5/16	15	5	24		1400	0.43
709-186-36X	24	20	36	23 5/16	19 5/16	36	6	69		1675	0.33	709-123-15X	12	24	15	11 5/16	23 5/16	15	3	16		1000	0.44
709-135-36X	20	24	36	19 5/16	23 5/16	36	5	65		1675	0.34	709-116-12X	24	24	12	23 5/16	23 5/16	12	6	26		2000	0.47
709-145-36X	20	20	36	19 5/16	19 5/16	36	5	58		1400	0.33	709-186-12X	24	20	12	23 5/16	19 5/16	12	6	23		1675	0.46
709-124-36X	12	24	36	11 5/16	23 5/16	36	4	52		1250	0.35	709-176-12X	20	25	12	19 5/16	24 5/16	12	6	27		1750	0.47
709-123-36X	12	24	36	11 5/16	23 5/16	36	3	39		1000	0.33	709-135-12X	20	24	12	19 5/16	23 5/16	12	5	22		1675	0.47
709-110-30X	24	24	30	23 5/16	23 5/16	30	10	107		2000	0.35	709-145-12X	20	20	12	19 5/16	19 5/16	12	5	19		1400	0.46
709-118-30X	24	24	30	23 5/16	23 5/16	30	8	85		2000	0.36	709-165-12X	16	25	12	15 5/16	24 5/16	12	5	22		1400	0.46
709-116-30X	24	24	30	23 5/16	23 5/16	30	6	64		2000	0.36	709-154-12X	16	20	12	15 5/16	19 5/16	12	4	15		1100	0.46
709-186-30X	24	20	30	23 5/16	19 5/16	30	6	54		1675	0.36	709-123-12X	12	24	12	11 5/16	23 5/16	12	3	13		1000	0.46
709-136-30X	20	24	30	19 5/16	23 5/16	30	6	64		1675	0.36	709-116-21X	24	24	21	23 5/16	23 5/16	21	6	45		1500	0.38
709-135-30X	20	24	30	19 5/16	23 5/16	30	5	53		1675	0.36	709-186-21X	24	20	21	23 5/16	19 5/16	21	6	40		1250	0.37
709-146-30X	20	20	30	19 5/16	19 5/16	30	6	57		1400	0.35	709-135-21X	20	24	21	19 5/16	23 5/16	21	5	37		1250	0.38
709-125-30X	12	24	30	11 5/16	23 5/16	30	5	53		1000	0.34	709-145-21X	20	20	21	19 5/16	19 5/16	21	5	33		1050	0.37
709-124-30X	12	24	30	11 5/16	23 5/16	30	4	43		1000	0.35	709-123-21X	12	24	21	11 5/16	23 5/16	21	3	22		750	0.37
709-123-30X	12	24	30	11 5/16	23 5/16	30	3	32		1000	0.35	709-110-15X	24	24	15	23 5/16	23 5/16	15	10	53		1500	0.40
709-118-26X	24	24	26	23 5/16	23 5/16	26	8	74		2000	0.37	709-116-15X	24	24	15	23 5/16	23 5/16	15	6	32		1500	0.42
709-116-26X	24	24	26	23 5/16	23 5/16	26	6	55		2000	0.38	709-125-15X	12	24	15	11 5/16	23 5/16	15	5	27		750	0.39
709-124-26X	12	24	26	11 5/16	23 5/16	26	4	37		1000	0.36	709-123-15X	12	24	15	11 5/16	23 5/16	15	3	16		750	0.41
709-123-26X	12	24	26	11 5/16	23 5/16	26	3	28		1000	0.37												

HEADER: 13/16" DEEP

HEADER MATERIAL:  
26 GAUGE GALVANIZED STEEL

POCKETS:  
ULTRASONICALLY WELDED POCKET SPACERS AND EDGES

FINAL RESISTANCE:  
1.0 IN. W.G. FOR ALL MODELS

INSTALLATION:  
RECOMMENDED INSTALL FILTER WITH POCKETS IN VERTICAL POSITION (AS SHOWN)

MEDIA:  
LAYERED, MELTBLOWN SYNTHETIC, PROTECTED BY A SCRIM ON THE AIR LEAVING SIDE

GASKET LOCATION OPTION: (LAST DIGIT OF AAF PART NUMBER)

- 0 - NO GASKET
- 1 - VERTICAL SIDES
- 2 - HORIZONTAL SIDES
- 3 - ALL FOUR SIDES
- 4 - FRONT FACE
- 5 - REAR FACE
- 6 - ALL FOUR SIDES & REAR FACE
- 7 - VERTICAL SIDES (ECONOMY)
- 8 - HORIZONTAL SIDES (ECONOMY)
- 9 - ONE (1) VERTICAL SIDE

OPERATING TEMPERATURE:  
OPERATING WITH FAN ON, ARE DESIGNED FOR A CONTINUOUS OPERATING TEMPERATURE OF 200°F (93°C)

TOLERANCES:  
DEPTH: ±1/4"  
HEIGHT AND WIDTH: ±1/8"

DriPak  A REGISTERED TRADEMARK

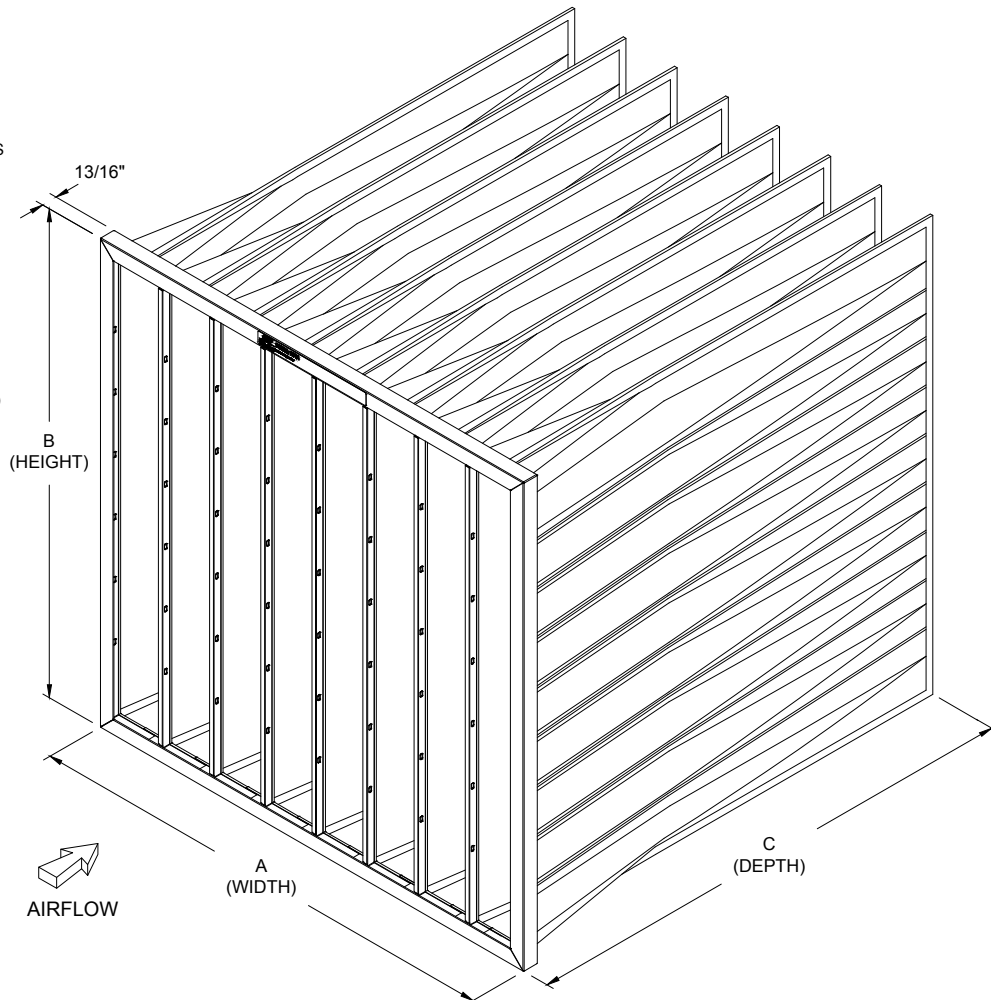

FORM 1297 REV. 5/00

DRAWN GAC	DATE 15APR2021	CHECKED GC	DATE 16APR2021	APPR. SH	DATE 19APR2021	SUPERSEDES
 <p style="text-align: center;">FILTER ASSEMBLY, DRIPAK MAX MERV 15 (90-95%)</p>						DRAWING NO.
						3177971
						REV A
P.O. Box 35690 Louisville, KY. 40232-5690 www.aafintl.com						SHEET 1 OF 1