

REVISIONS

| | | |
|---|---|--|
| A (A02607) REVISED NAMEPLATE GRAPHICS GAC 21NOV2023 - GC 21NOV2023 - KM 21NOV2023 | C (A02679) REVISED ALL 3184627-6XX MERV RATING, WAS 14 GAC 21MAR2025 - GC 21MAR2025 - KM 21MAR2025 | |
| B (A02662) ADDED MERV 11 PART NUMBERS GAC 19NOV2024 - GC 19NOV2024 - KM 14JAN2025 | D (A02734) REVISED 3184627-611, -811, AND -911 MEDIA AREA; WAS 09.8 GAC 08MAY2026 - GC 08MAY2026 - KM 11MAY2026 | |

| AAF PART NUMBER | NOMINAL SIZE | | ACTUAL SIZE | | RATED AIRFLOW (CFM) | MEDIA AREA (ft²) | RATED INITIAL RESISTANCE @ 500 FPM (in. W.G.) | RECOMMENDED FINAL RESISTANCE (in. W.G.) | ASHRAE 52.2 MERV | CONTINUOUS OPERATING TEMPERATURE LIMITS | | FILTERS PER CARTON |
|-----------------|--------------|----------|--------------|--------------|---------------------|------------------|---|---|------------------|---|-------|--------------------|
| | W | H | W | H | | | | | | DEG F | DEG C | |
| 3184627-601 | 12 [305] | 24 [610] | 11 3/8 [289] | 23 3/8 [593] | 1000 | 22.2 | 0.27 | 1.50 | 11 | 150 | 66 | 4 |
| 3184627-602 | 16 [406] | 20 [508] | 15 3/8 [390] | 19 3/8 [492] | 1100 | 25.4 | | | | | | |
| 3184627-603 | 16 [406] | 25 [635] | 24 3/8 [619] | 15 3/8 [390] | 1400 | 32.3 | | | | | | |
| 3184627-604 | 18 [457] | 24 [610] | 17 3/8 [441] | 23 3/8 [593] | 1500 | 36.3 | | | | | | |
| 3184627-605 | 20 [508] | 20 [508] | 19 3/8 [492] | 19 3/8 [492] | 1400 | 32.8 | | | | | | |
| 3184627-606 | 20 [508] | 24 [610] | 19 3/8 [492] | 23 3/8 [593] | 1650 | 40.4 | | | | | | |
| 3184627-607 | 20 [508] | 25 [635] | 24 3/8 [619] | 19 3/8 [492] | 1750 | 41.9 | | | | | | |
| 3184627-608 | 24 [610] | 24 [610] | 23 3/8 [593] | 23 3/8 [593] | 2000 | 49.4 | | | | | | |
| 3184627-611 | 12 [305] | 12 [305] | 11 3/8 [289] | 11 3/8 [289] | 500 | 9.8 | | | | | | |
| 3184627-801 | 12 [305] | 24 [610] | 11 3/8 [289] | 23 3/8 [593] | 1000 | 22.2 | | | | | | |
| 3184627-802 | 16 [406] | 20 [508] | 15 3/8 [390] | 19 3/8 [492] | 1100 | 25.4 | | | | | | |
| 3184627-803 | 16 [406] | 25 [635] | 24 3/8 [619] | 15 3/8 [390] | 1400 | 32.3 | | | | | | |
| 3184627-804 | 18 [457] | 24 [610] | 17 3/8 [441] | 23 3/8 [593] | 1500 | 36.3 | | | | | | |
| 3184627-805 | 20 [508] | 20 [508] | 19 3/8 [492] | 19 3/8 [492] | 1400 | 32.8 | | | | | | |
| 3184627-806 | 20 [508] | 24 [610] | 19 3/8 [492] | 23 3/8 [593] | 1650 | 40.4 | | | | | | |
| 3184627-807 | 20 [508] | 25 [635] | 24 3/8 [619] | 19 3/8 [492] | 1750 | 41.9 | | | | | | |
| 3184627-808 | 24 [610] | 24 [610] | 23 3/8 [593] | 23 3/8 [593] | 2000 | 49.4 | | | | | | |
| 3184627-811 | 12 [305] | 12 [305] | 11 3/8 [289] | 11 3/8 [289] | 500 | 9.8 | | | | | | |
| 3184627-901 | 12 [305] | 24 [610] | 11 3/8 [289] | 23 3/8 [593] | 1000 | 22.2 | | | | | | |
| 3184627-902 | 16 [406] | 20 [508] | 15 3/8 [390] | 19 3/8 [492] | 1100 | 25.4 | | | | | | |
| 3184627-903 | 16 [406] | 25 [635] | 24 3/8 [619] | 15 3/8 [390] | 1400 | 32.3 | | | | | | |
| 3184627-904 | 18 [457] | 24 [610] | 17 3/8 [441] | 23 3/8 [593] | 1500 | 36.3 | | | | | | |
| 3184627-905 | 20 [508] | 20 [508] | 19 3/8 [492] | 19 3/8 [492] | 1400 | 32.8 | | | | | | |
| 3184627-906 | 20 [508] | 24 [610] | 19 3/8 [492] | 23 3/8 [593] | 1650 | 40.4 | | | | | | |
| 3184627-907 | 20 [508] | 25 [635] | 24 3/8 [619] | 19 3/8 [492] | 1750 | 41.9 | | | | | | |
| 3184627-908 | 24 [610] | 24 [610] | 23 3/8 [593] | 23 3/8 [593] | 2000 | 49.4 | | | | | | |
| 3184627-911 | 12 [305] | 12 [305] | 11 3/8 [289] | 11 3/8 [289] | 500 | 9.8 | | | | | | |

FRAME:
HIGH IMPACT POLYSTYRENE, COLOR - BLACK

MEDIA:
100% SYNTHETIC FIBER UNIFORM MEDIA
WITH CONTROLLED FIBER SIZE AND BLEND

SEPARATOR:
EMBOSSED FILTER MEDIA - SELF SPACING

ASSEMBLY ADHESIVE:
POLYURETHANE

TOLERANCES:
DEPTH: ±1/16"
HEIGHT AND WIDTH: ±1/8"

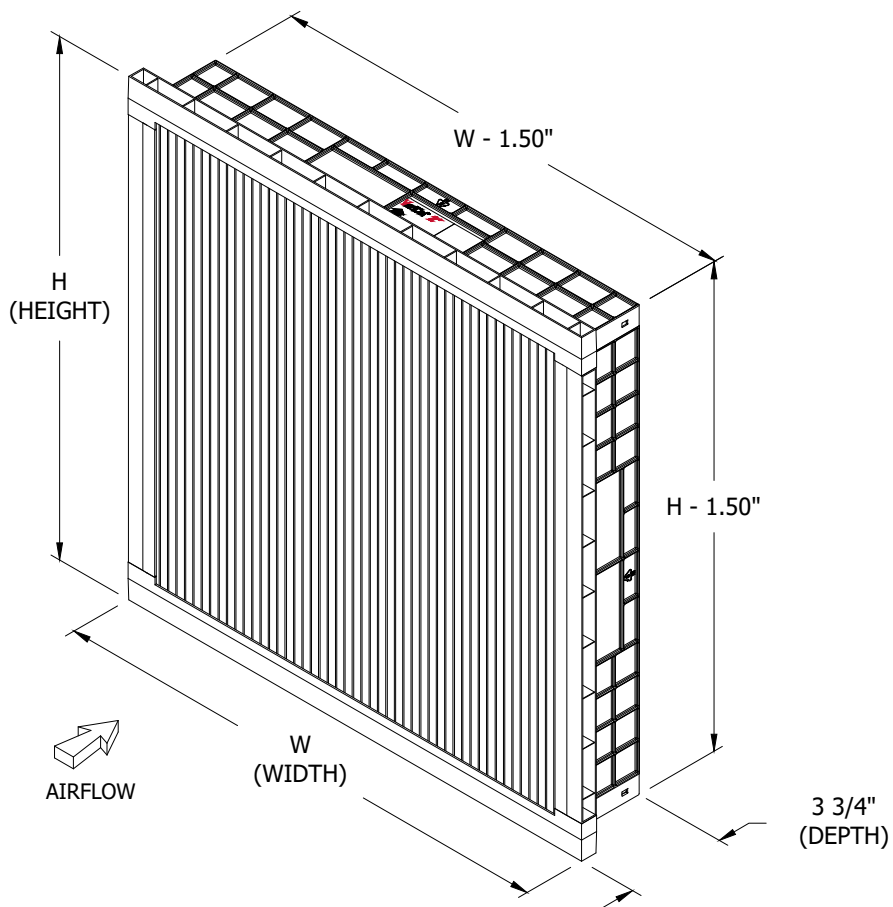

FORM I297 REV. 5/00

| | | | | | | | |
|---|-------------------|---------------|-------------------|-------------|-------------------|--|----------|
| DRAWN GAC | DATE 27FEB2023 | CHECKED GC | DATE 27FEB2023 | APPR. KM | DATE 28FEB2023 | DRAWING NO. 3185565 | REV D |
|  P.O. Box 35690 Louisville, KY. 40232-5690 www.aafintl.com | | | | | | FILTER ASSEMBLY, VARICEL 2+ (SH STD AF) (SUBMITTAL) | |
| | | | | | | SHEET 1 OF 1 | |