

REVISIONS

PART NUMBER	NOMINAL SIZE	ACTUAL SIZE (H x W x D)	MEDIA AREA (Sq. Ft.)	RATED AIRFLOW CAPACITY (SCFM)		GASKET LOCATION	RATING
				LOW - 0.15" WG	HIGH - 0.20" WG		
3192759-001	24 x 12 x 12	11.375 x 23.375 x 12.00	88	350	460	X	MERV 16
3192759-002	24 x 20 x 12	19.375 x 23.375 x 12.00	161	620	770		
3192759-003	24 x 24 x 12	23.375 x 23.375 x 12.00	200	700	930		
3192759-004	24 x 12 x 12	11.375 x 23.375 x 12.00	88	350	460	ALS	
3192759-005	24 x 20 x 12	19.375 x 23.375 x 12.00	161	620	770		
3192759-006	24 x 24 x 12	23.375 x 23.375 x 12.00	200	700	930		

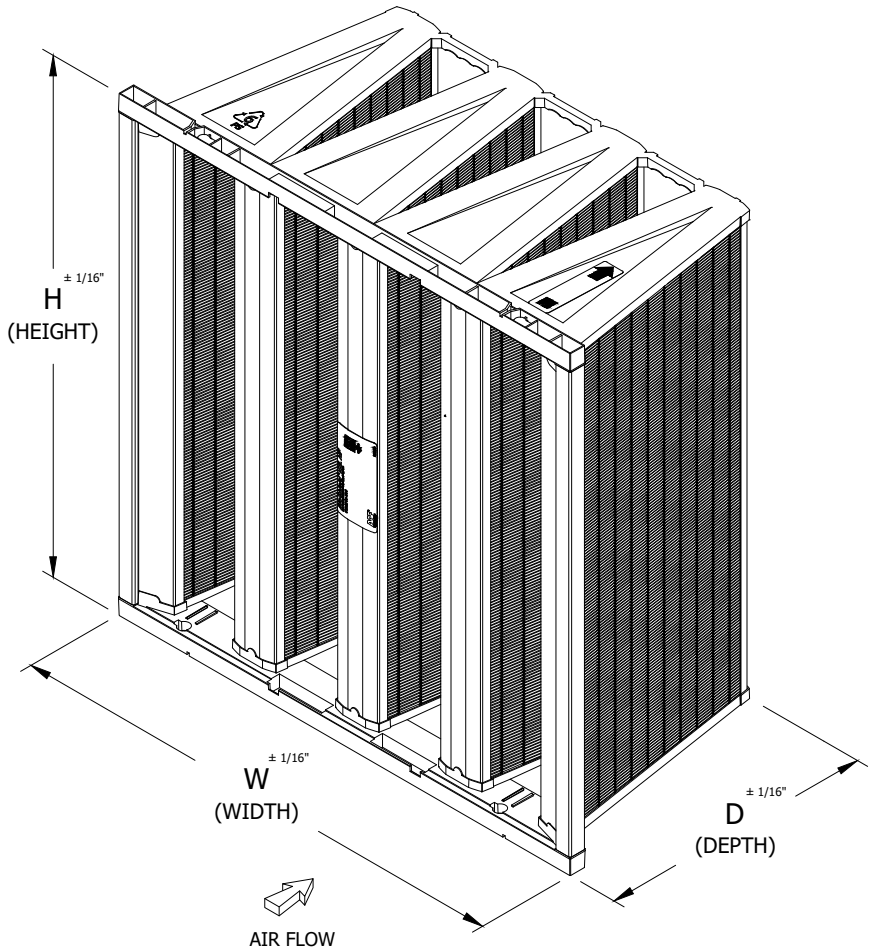

GENERAL NOTES:

- 1 Materials of Construction:
 - A. Media: Single density, Microglass Paper
 - B. Separators: Adhesive bead separators
 - C. Frame: Recycled high impact polystyrene
 - D. Sealant: Polyurethane

- 2 ASHRAE ratings/resistance at 500 FPM

MERV 16 0.49" W.G.

Testing in accordance with ASHRAE Standard 52.2
Maximum recommended final resistance is 2" W.G.

- 3 Maximum operating temperature 176° F (80° C)
- 4 Recommended Final Resistance 1.5" W.G.
- 5 Fully Incinerable

FORM I297 REV. 5/00

DRAWN GAC	DATE 27MAY2026	CHECKED GC	DATE 27MAY2026	APPR. KM	DATE 01JUN2026
--------------	-------------------	---------------	-------------------	-------------	-------------------



P.O. Box 35690
Louisville, KY.
40232-5690
www.aafintl.com

FILTER ASSEMBLY, BioShield VXL HF
(SALES)

DRAWING NO.	REV
3193032	--
SHEET 1 OF 1	