

***Use and Maintenance Manual for
winch with 6000 kg capacity
- W 6 -***

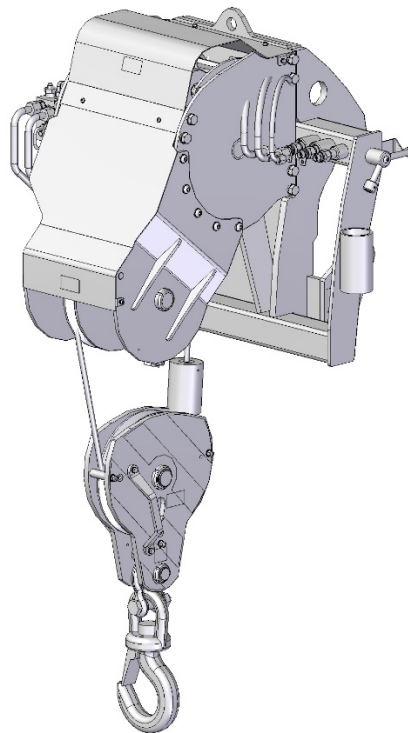

-- TRANSLATION OF THE ORIGINAL INSTRUCTIONS --

Prepared in compliance with the essential requirement for the protection of health and safety 1.7.4 of annex I of directive 2006/42/EC

Magni Telescopic Handlers Srl

Via Magellano, 22 - 41013 Castelfranco Emilia (MO) - ITALY

Tel. +39 059 8031000 • Fax +39 059 8638012 • P. IVA/C.F. IT03353620366 • SDI: XMXAUP4 • Capitale Sociale 1.262.500 Euro i.v.
www.magnith.com

Instructions and warnings for safe use

Introduction

The user must strictly follow the indications given below:

- ✓ The Manufacturer has designed the accessory accurately, with the help of appropriate tools and technologies to ensure its safety; however, it is difficult to assess all the work situations the equipment may be subject to in different operating conditions. Consequently, the user is responsible not only for following the indications given in this *Use and Maintenance Manual*, but also for adopting the methods for use that take into account the provisions and legislation on occupational health and safety in force in the country in which the equipment is used, associated with responsible use of the equipment, capable of foreseeing and preventing potential danger situations generated by special logistic, climatic, visibility and health conditions of the user.
- ✓ Operations or movements not described in this Use and Maintenance Manual must be avoided; the person using methods other than those recommended must first ensure his own safety, the safety of others and correct handling of the equipment;
- ✓ **Failure to comply with the safety regulations listed in the Use and Maintenance Manual for the use, maintenance and repair of the accessory can result in serious accidents, sometimes even fatal.**

User obligations

- ✓ **Read the Use and Maintenance Manual carefully;**
- ✓ **Before using the equipment, ensure its compatibility with the forklift truck with which it is to be used;**
- ✓ **Become acquainted with the operating area: quality of the road surface, obstacles on the ground or high up;**
- ✓ **Operating temperature: min -15 °C; max +45 °C;**
- ✓ **Comply with the data indicated on the load charts. Do not attempt to lift weights exceeding those permitted on the load charts attached to the vehicle, under any circumstances whatsoever;**
- ✓ **If the lifting capacity of the accessory is different from that of the crane, take the lesser of the two as the maximum limit;**
- ✓ **It is strictly forbidden to tamper with the safety devices provided on the equipment;**
- ✓ **The equipment must not be modified to increase its lifting capacity;**
- ✓ **Keep the load low and with the telescopic boom completely retracted;**
- ✓ **Adjust the forklift truck speed to the ground conditions;**
- ✓ **Avoid sudden movements while handling the load;**
- ✓ **Do not use the equipment in the vicinity of overhead electricity lines; always keep at a safety distance of at least 5 m, especially where these are powered, or their state is not known;**
- ✓ **Prevent the possibility of outsiders moving around in the work areas by means of warning signs and barriers in compliance with the regulations, provisions and laws on the matter of work safety established in the different countries in which the equipment is used;**
- ✓ **Only transport loads that are properly balanced;**
- ✓ **The equipment must be lowered to the ground in a hazard-free area devoid of obstacles;**
- ✓ **The empty hook must be lowered gently, to prevent abnormal stresses on the rope which can damage the rope itself or the equipment structure;**
- ✓ **Never leave the forklift truck parked with a raised load;**
- ✓ **The operator must stop using the vehicle if visibility and lighting conditions are poor;**
- ✓ **While working at a height, constantly check that the wind speed never exceeds 45 km/h. In case of strong wind, retract the equipment immediately, as the specific wind pressure on hanging loads can overload the forklift truck and affect its stability;**
- ✓ **Do not use the equipment in particularly adverse weather conditions (storms with lightning);**
- ✓ **The forklift truck, carrying equipment fitted with ropes, must be inspected periodically as envisaged for lifting equipment, in compliance with legislation, provisions and regulations applicable in the country of use. The user alone is responsible for ensuring compliance with the legislation in force;**
- ✓ **Before starting work with the equipment or other lifting equipment with hook, inform the authorities responsible for inspections in your area (INAIL in Italy only);**
- ✓ **Contact the Local Health Authority for your area for yearly inspections (in Italy only).**

Conditions for using the forks in case of wind

- ✓ The forks can also be used if wind is present, provided they do not exceed Grade 6 of the Beaufort Scale (speed 49 km/h; 27 nodes; 13.8 m/s);
- ✓ For visual identification of this speed, refer to the Beaufort Scale below for empiric evaluation of the wind speed.

BEAUFORT WIND SCALE					
force	speed (km/h)	speed (mi/h)	speed (m/s)	wind type	wind effects
0	0 - 1	0 - 1	> 0.3	calm	smoke rises vertically; sea surface mirror-like.
1	1 - 5	1 - 4	0.3 - 1.5	light air	wind causes smoke to drift; ripples on water.
2	6 - 11	5 - 7	1.6 - 3.3	light breeze	leaves rustle; small wavelets.
3	12 - 19	8 - 11	3.4 - 5.4	gentle breeze	leaves and twigs constantly moving; large wavelets, crests begin to break.
4	20 - 28	12 - 18	5.5 - 7.9	moderate breeze	the wind raises dust, dry leaves, small tree branches constantly moving; small waves becoming longer.
5	29 - 38	19 - 24	8 - 10.7	fresh breeze	small trees in leaf begin to sway; small waves formed in internal waters; waves become moderately longer.
6	39 - 49	25 - 31	10.8 - 13.8	strong breeze	larger tree branches moving, whistling in telegraph wires; whitecaps on the sea surface and spray.
7	50 - 61	32 - 38	13.9 - 17.1	near gale	whole trees moving, resistance when walking against wind; sea heaps up, white foam streaks of breakers.
8	62 - 74	39 - 46	17.2 - 20.7	gale	twigs breaking off trees, walking against wind becomes impossible, moderately high waves of greater length, edges of crests begin to break into spindrift.
9	75 - 88	47 - 54	20.8 - 24.4	strong gale	shingles and tiles blown away; high waves, dense streaks of foam and spray, raised by wind, reduce the visibility.
10	89 - 102	55 - 63	24.5 - 28.4	storm	seldom experienced on land, trees uprooted, considerable damage to dwellings; very high waves with long overhanging crests.
11	103 - 117	64 - 73	28.5 - 32.6	violent storm	rare, severe devastation; enormous high waves, which can conceal medium sized ships; poor visibility.
12	beyond 118	74 +	32.7 +	hurricane	destruction of buildings, constructions etc.; foam and sprays in the seas reduce visibility to a very great extent.

Instructions for using the equipment

Positioning and hooking to the boom

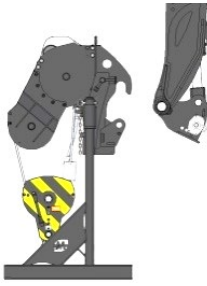
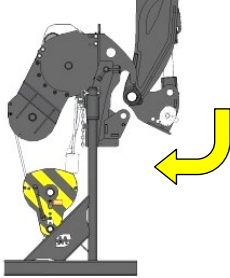
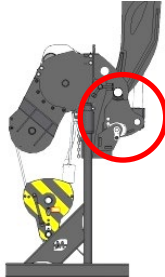
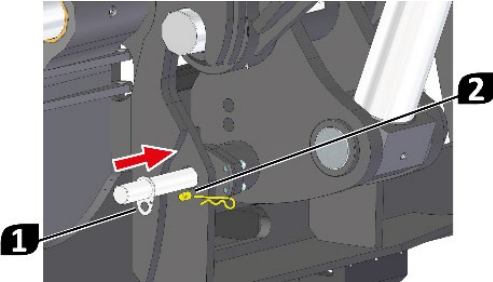
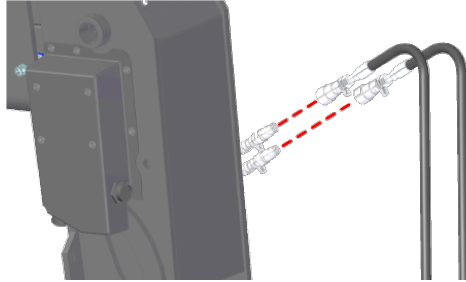
<ul style="list-style-type: none"> ✓ position the equipment on a stable level surface; ✓ bring the forklift truck near the equipment, positioning the end part of the boom with the quick-fit coupling retracted suitably to fit it in the hooking seat; 	
<p>Potential risks during the operation:</p> <ul style="list-style-type: none"> ✓ make sure that there is no one in the areas near the vehicle and the equipment. 	
<ul style="list-style-type: none"> ✓ fit the equipment with the boom head quick-fit coupling; ✓ tilt the boom head coupling round to the equipment frame to insert the shear pin; 	
<ul style="list-style-type: none"> ✓ align the hole present on the connecting flange of the boom with that present on the equipment hooking structure; 	
<ul style="list-style-type: none"> ✓ insert the retainer pin [1] into the hole present on the connecting flange of the boom aligned with the hole present on the equipment hooking structure; ✓ insert the shear pin [2] in the hole present on the pin which is integral with the equipment structure in such a manner as to prevent it from coming loose; 	
<p>Potential risks during the operation:</p> <ul style="list-style-type: none"> ✓ Attention! crushing of the upper limbs. 	
<ul style="list-style-type: none"> ✓ insert the quick-release couplings of the accessory's hydraulic system in the connectors on the boom; 	
<p>Potential risks during the operation:</p> <ul style="list-style-type: none"> ✓ Attention! crushing of the upper limbs. 	

<ul style="list-style-type: none"> ✓ When the forklift truck starts up, the display shows the information regarding the accessory detected, with the descriptive text and photo: ✓ press the GREEN button to confirm recognition of the accessory; ✓ press the RED button if a different accessory to that attached is recognised. 	
---------------------------------------------------------------------------------------------------------------------------------------------------------------------------------------------------------------------------------------------------------------------------------------------------------------------------------------------------------------------	--

If the accessory is not recognised, check the state of preservation of the transmitter present on the accessory and of the receiver present at the head of the boom. If there is no evident damage, contact Magni Telescopic Handlers Assistance Service.
If the RED button is pressed, the forklift truck will have limited operation and load capacity for safety reasons.

<ul style="list-style-type: none"> ✓ Before using the accessory, remove the supporting base after removing the retainer pins. 	
----------------------------------------------------------------------------------------------------------------------------------------------	--

Managing the accessory's controls from the cab

	<p>The accessory, like the entire vehicle, can only be operated by the operator seated correctly in the cab.</p> <p>If this condition is not present, all the commands imparted are inhibited and this fault is signalled by means of a flashing light on the control panel on the side of the seat.</p>	
	<p>Inside the grip of each servo control there is a button with the "movement enable" function: press this button to impart a command to the forklift truck or accessory attached.</p> <p>Absence of the procedure is displayed on the control panel.</p>	

Managing the accessory's controls from the RTH

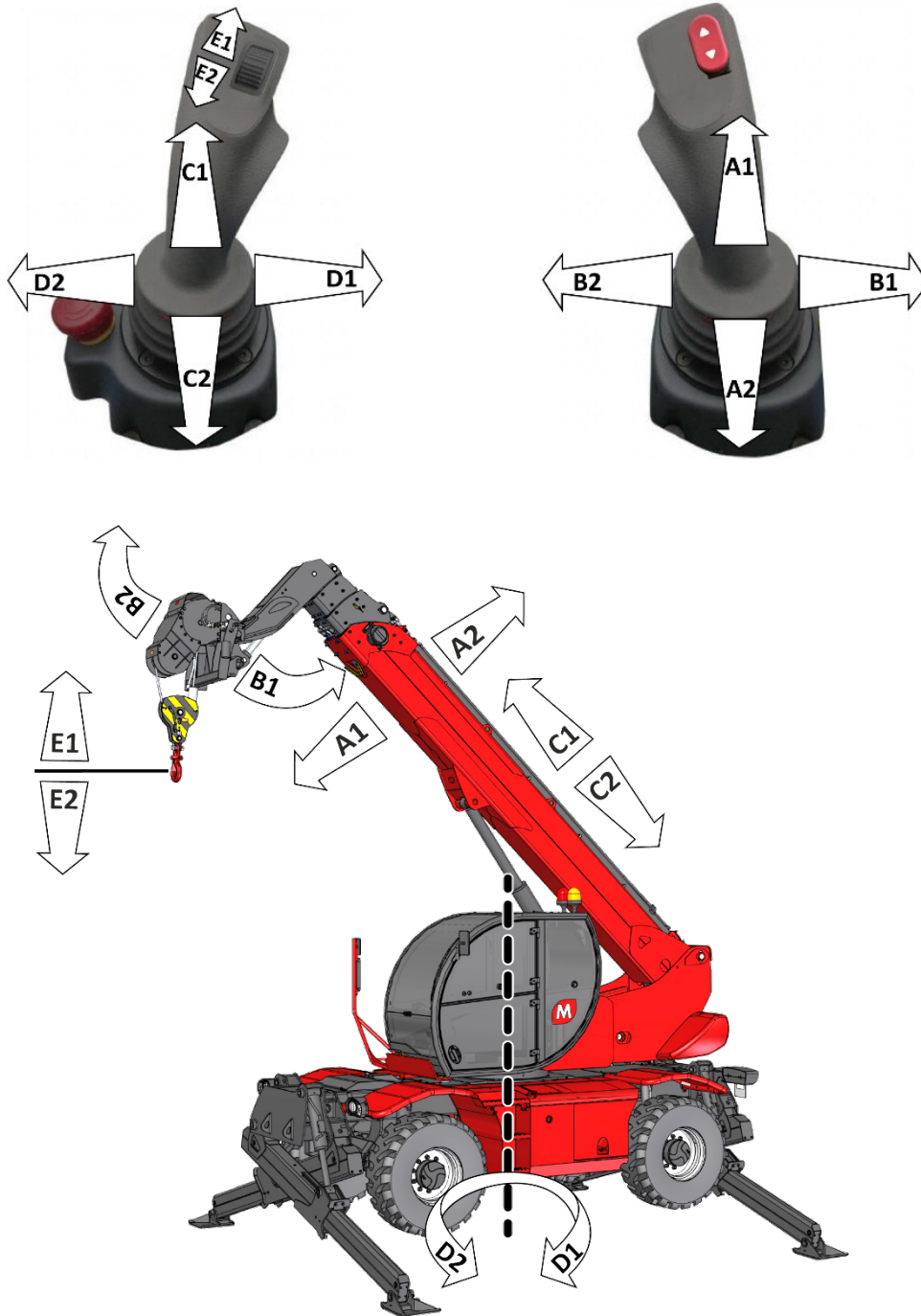

- A1:** move the right joystick forward to lower the telescopic boom;
- A2:** move the right joystick backward to raise the telescopic boom;
- B1:** move the right joystick to the right to tilt the accessory downward;
- B2:** move the left joystick to the right to tilt the accessory upward;
- C1:** move the left joystick forward to extend the telescopic boom;
- C2:** move the left joystick backward to retract the telescopic boom;
- D1:** move the left joystick to the right to rotate the vehicle's turret clockwise;
- D2:** move the left joystick to the left to rotate the vehicle's turret anticlockwise;
- E1:** rotate the roller forward to wind the rope / lift the hook;
- E2:** rotate the roller backward to unwind the rope / drop the hook.

Managing the accessory's controls from the TH

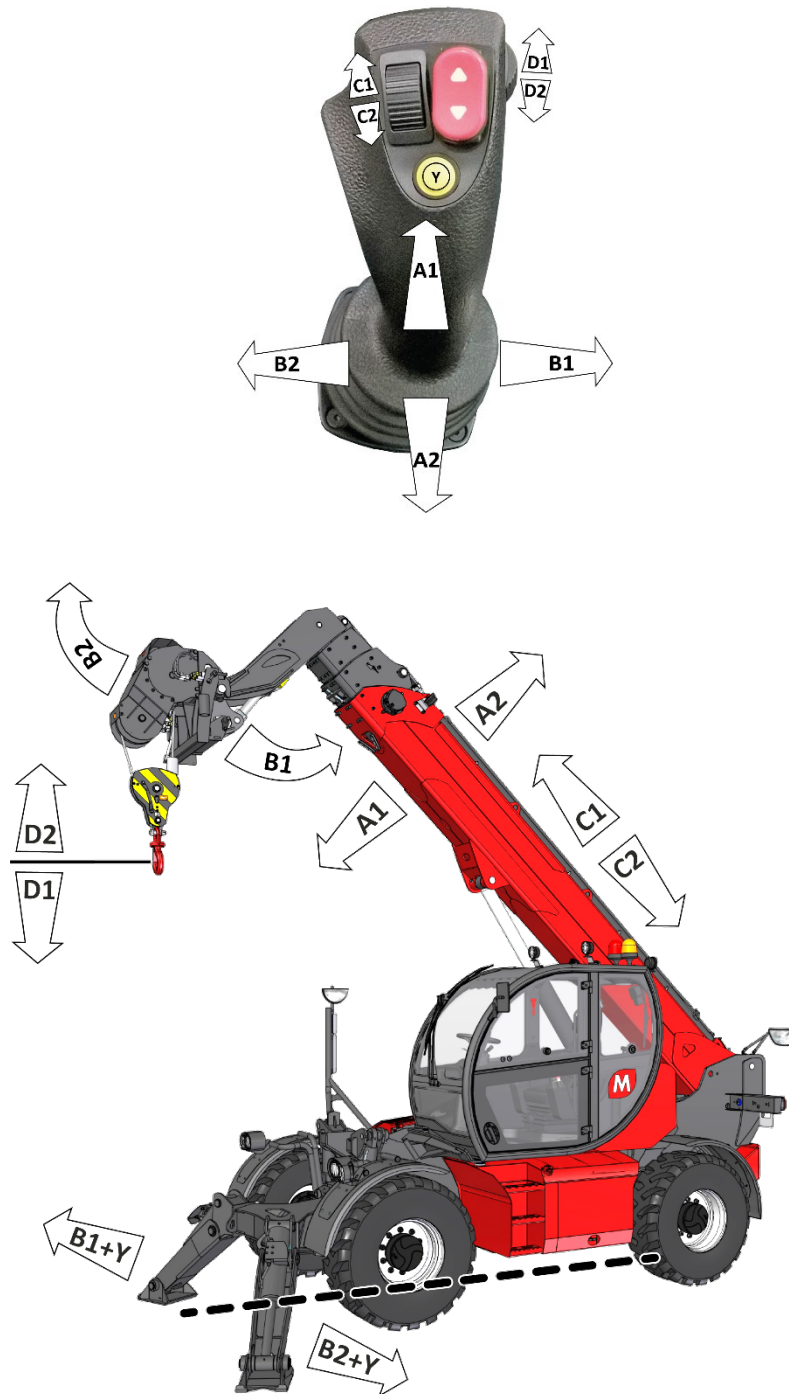

A1: move the joystick forward to lower the telescopic boom;

A2: move the joystick backward to raise the telescopic boom;

B1: move the joystick to the right to tilt the accessory downward;

B2: move the joystick to the left to tilt the accessory upward;

B1 + Y button: move the joystick to the right to move the carriage to the right;

B2 + Y button: move the joystick to the left to move the carriage to the left;

C1: rotate the upper roller forward to extend the telescopic boom;

C2: rotate the upper roller backward to retract the telescopic boom;

D1: rotate the side roller forward to unwind the rope / drop the hook;

D2: rotate the side roller backward to wind the rope / lift the hook.

Controls on the radio control

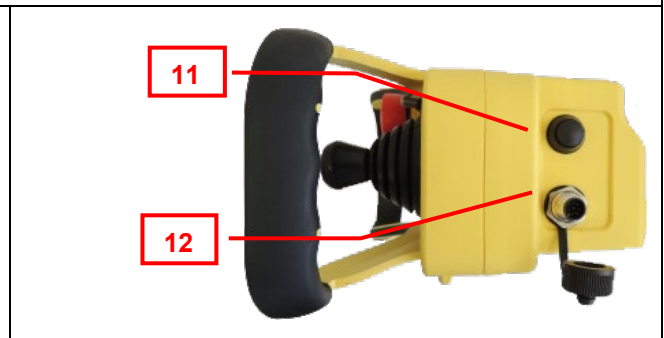
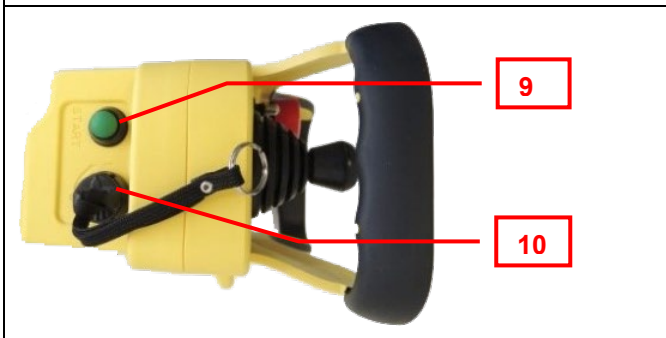
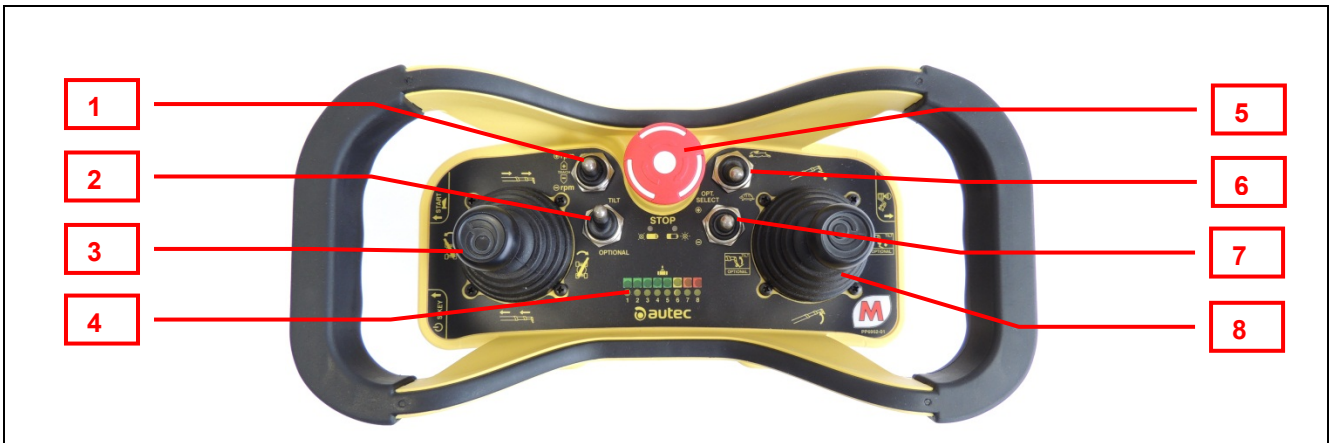

1. RPM switch;
2. TILT - OPTIONAL switch: swaps the controls from the machine to the accessory;
3. left joystick;
4. OPTIONAL program selected / load limits indication LED;
5. emergency stop button;
6. hare/tortoise button;
7. OPT.SELECT button for selecting operation of accessories with greater degree of freedom;
8. right joystick;
9. button to activate connection with the machine;
10. radio control switch;
11. emergency pump activation button;
12. socket for overhead platform wiring connector.

Activation procedure for using the radio control panel

When the equipment is already connected to the forklift truck, proceed as follows:

<ul style="list-style-type: none"> ✓ start the vehicle and confirm the accessory, ✓ position the vehicle on stabilisers. 	
<ul style="list-style-type: none"> ✓ make sure that the reverse gear is in NEUTRAL, ✓ engage the vehicle's parking brake by pressing the button under the steering wheel, ✓ check that the specific indicator lights up. 	
<ul style="list-style-type: none"> ✓ activate the forklift truck connection with the radio control by pressing the key on the "stabilisers page" or "controls page". 	 <p style="text-align: center;"> Stabilisers page Controls page </p>
<ul style="list-style-type: none"> ✓ turn the radio control on by turning the key on the left side, ✓ make sure that the red emergency button is not locked in the safety position: check by turning it clockwise. 	
<ul style="list-style-type: none"> ✓ press the green button (once) for recognition of the radio-control by the system; ✓ when the connection has been made the vehicle horn makes a warning sound. 	

After this sequence of operations, the radio-control is operative.

If connection between the radio control and the forklift truck has been interrupted by the red emergency button being pressed (for the vehicle or radio control), reactivate it as follows:

- 1- reset the red mushroom-shaped button by rotating it counter-clockwise,
- 2- press the green radio control button once to reactivate the radio control/forklift truck connection, confirmed by the vehicle horn making a warning sound,
- 3- press the green radio control button again to start the vehicle's I.C. engine, confirmed by the vehicle horn making a warning sound.

After this sequence of operations, the radio-control is operative.

Management of the controls from the radio control

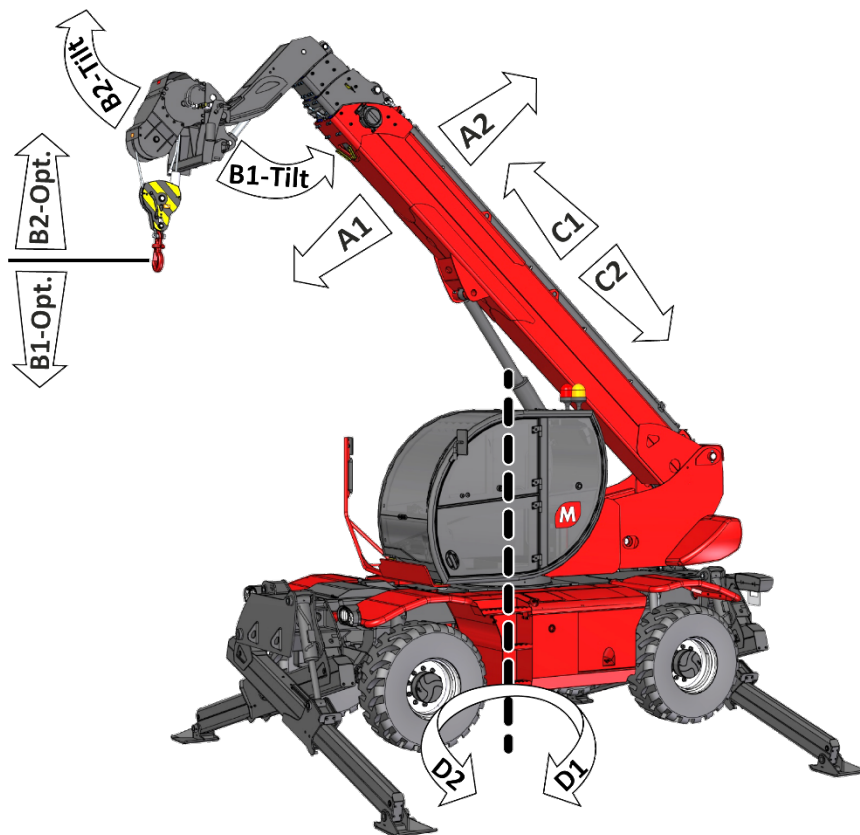
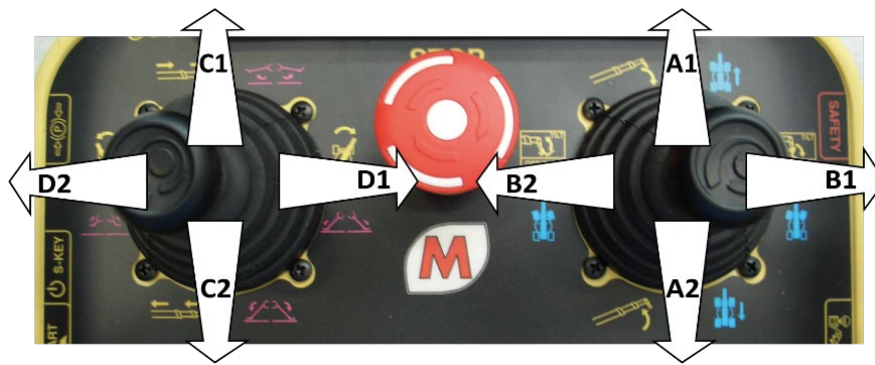

A1: move the right joystick forward to lower the telescopic boom;

A2: move the right joystick backward to raise the telescopic boom;

B1 with TILT function: move the right joystick to the right to tilt the accessory downward;

B2 with TILT function: move the right joystick to the left to tilt the accessory upward;

C1: move the left joystick forward to extend the telescopic boom;

C2: move the left joystick backward to retract the telescopic boom;

D1: move the left joystick to the right to rotate the vehicle's turret clockwise;

D2: move the left joystick to the left to rotate the vehicle's turret anticlockwise;

B1 with Optional function: move the right joystick to the right to unwind the rope / drop the hook;

B2 with Optional function: move the right joystick to the left to wind the rope / lift the hook.

Emergency stop



In dangerous conditions, press the red emergency button either inside the vehicle's cab next to the left joystick (**RTH**) or right dashboard (**TH**) and in the centre of the radio control to stop every forklift truck and accessory movement.



RTH



TH



Radio control

To re-enable vehicle/accessory movements, reset the red emergency button by turning it clockwise, then restart the vehicle and/or reconnect the radio control.