

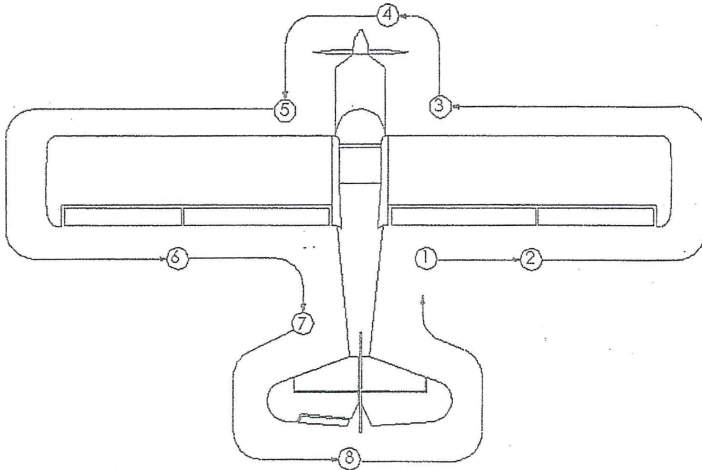

PREFLIGHT INSPECTION - LN-SDB



PREFLIGHT INSPECTION

1. Release controls.
2. Check ignition switches "OFF."
3. Check fuel quantity on fuel gauges.
4. Fuel valve "ON,"
5. Inspect seat belt for condition.
6. Secure rear seat belts and all other loose or hanging objects if not in use.
7. Emergency locator transmitter armed.
8. Check right wing root cover for security.
9. Check aileron for freedom of movement and security.
10. Check wing & struts for general condition.
11. Check right main wheel for proper inflation.
12. Visually check fuel quantity, then check filler cap security.

13. Check pitot-static tube for stoppage.
14. Check oil level and secure dip stick.
15. Inspect engine compartment for general condition, fuel leaks, oil leaks, etc.
16. On first flight each day, drain fuel from gascolator.
17. Check that the oil dip stick access door is properly latched.
18. Check windshield for cleanness.
19. Check prop for nicks and prop spinner for security.
20. Check prop blade shanks for evidence of excessive bearing grease leakage.
21. Check air filter for cleanliness and security
22. Check left main wheel for proper inflation.
23. Check left fuel tank quantity, and then check filler cap security.
24. Inspect stall warning vane for freedom.
25. Inspect fuel vent for stoppage.
26. Check pitot tube for stoppage.
27. Check wing root cover for security.
28. Check aileron for freedom of movement and security.
29. Check wing & struts for general condition.

* Determine that the rear seat folding back has restrainer cables to prevent back from folding completely forward and interfering with rear stick movement.++

30.11.2015