

INSIDE OF DOOR

OUTSIDE OF DOOR

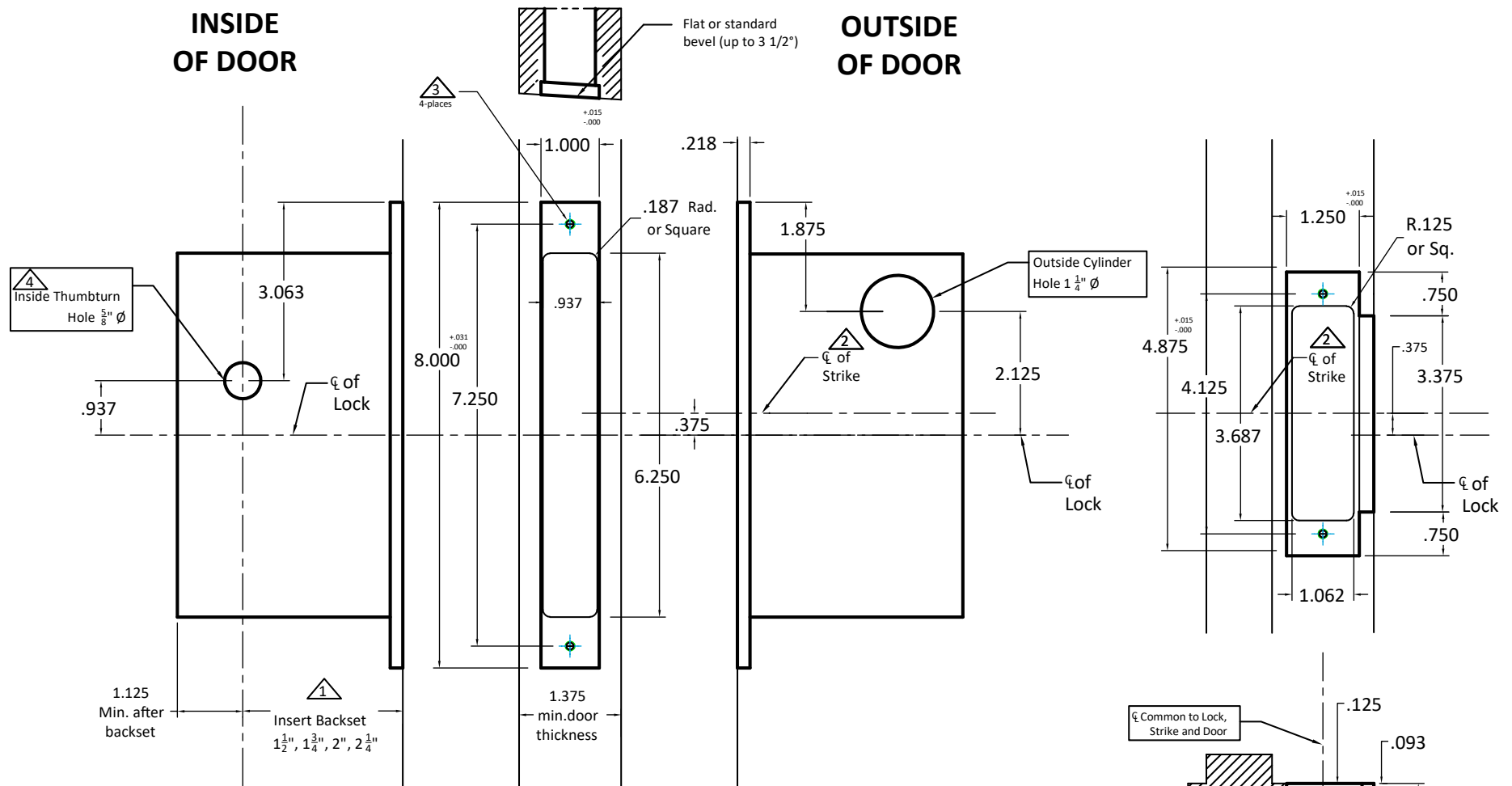

Important Notes:

- ① Insert backset here $1\frac{1}{2}$ ", $1\frac{3}{4}$ ", 2", $2\frac{1}{4}$ "
- ② ASA strike mounted $\frac{3}{8}$ " ABOVE centerline of lock
- ③ Prep for #12 wood or 12-24 machine screws (Lock and Strike)
- ④ Thumbturn hole may vary from different trim manufacturers. Please refer to their templates to confirm these dimensions.

Additional Notes:

- a) **Responsibility:** Door and frame manufacturers are responsible for providing adequate construction or re-inforcement for proper installation of hardware shown.
- b) Please contact us if a double lip strike is needed - for a proper template
- c) See catalog / spec sheets for additional lock details



ACCURATE
LOCK & HARDWARE
AMERICAN CRAFTED SINCE 1972

Standard 8724ARL
All Backsets

T-ALH.8724ARL