



SMARTENTRY<sup>TM</sup>  
by ACCURATE

Smart Mortise Lock User Manual

---

## TABLE OF CONTENTS

### Getting Started

Download SmartEntry App.....	3
Create and Account.....	4-5
Set Up Product.....	6-7
Transfer Ownership.....	8-9
Enter Payment.....	10

### SmartEntry App

Features + Functions.....	11
Control Lock Settings.....	12
About Product.....	13
Events.....	14
User Management.....	15
Setting Up a Schedule.....	16-17
Edit Schedule.....	18
Adding a Keyfob.....	19-20
Editing a Keyfob User.....	21-22
Keypad Info.....	23-28
Hardwiring Instructions.....	29
Help Center.....	30
Menu.....	31-32

### Ethernet Bridge

Features + Functions.....	33
Plug In + Power Up.....	34
Register Server.....	35-36

### Range Extender

Features + Functions.....	37
Plug In + Power Up.....	38
Register Server.....	39-40

**GETTING STARTED: DOWNLOAD THE APP**

**PACKAGE CONTENTS**

- + Smart Mortise Lock
- + CPU Unit
- + Battery Pack

Scan this QR code to download the SmartEntry app



Download the app from the Apple store or the Google Play store by searching “Accurate Lock Smart Entry” and look for this logo



## GETTING STARTED: CREATE AN ACCOUNT

After downloading the app, the first step is to create a SmartEntry account.

**Installer:** Please email [smartentry@accuratelockandhardware.com](mailto:smartentry@accuratelockandhardware.com) to become an approved installer and bypass payment process. (Lock will be fully activated when transferred to homeowner and payment is made. There is a 7 day window to complete the transfer. If not completed, process must be restarted).

**Homeowner:** If the homeowner is present during the install, please follow prompts and provide payment information accordingly (no need to email or bypass payment).



1/5

- Open SmartEntry app

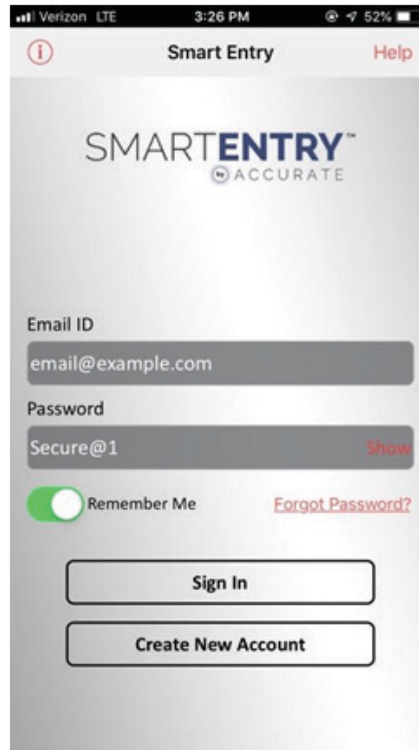

2/5

- Tap on Create an Account

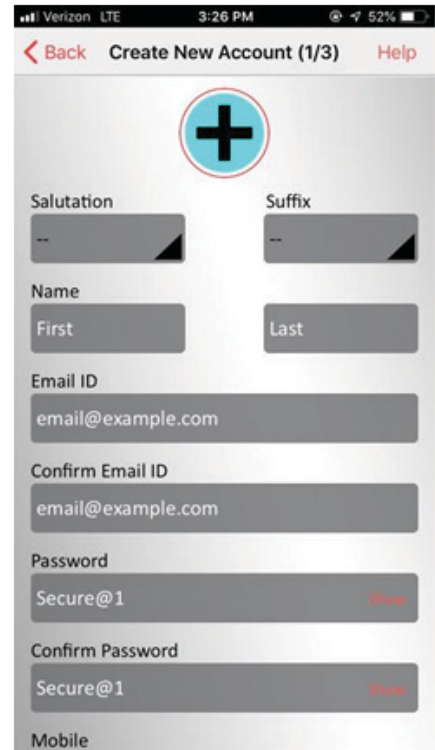

3/5

- Provide information requested

**GETTING STARTED: CREATE AN ACCOUNT** (continued)



4/5

- Click on red locator icon to populate current address automatically or you can also enter it manually

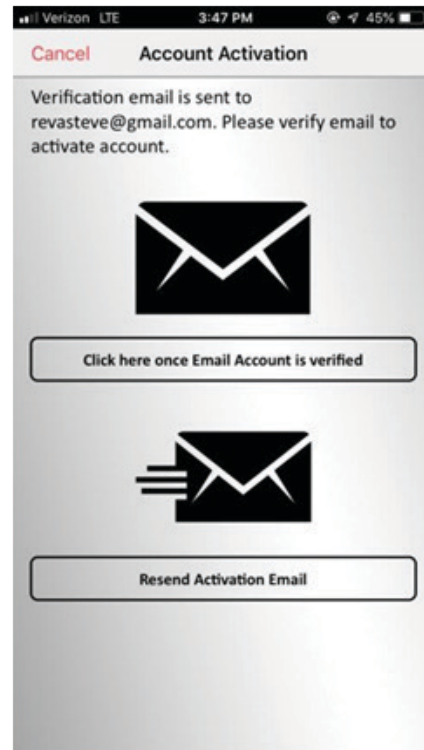

5/5

- You will receive a verification email once you have created an account
- Please check spam folder if you don't see in inbox.

## GETTING STARTED: SET UP PRODUCT

Keep Bluetooth on and stay in range.



1/7

- To set up your SmartEntry lock for the first time, click on + sign on middle of the screen.

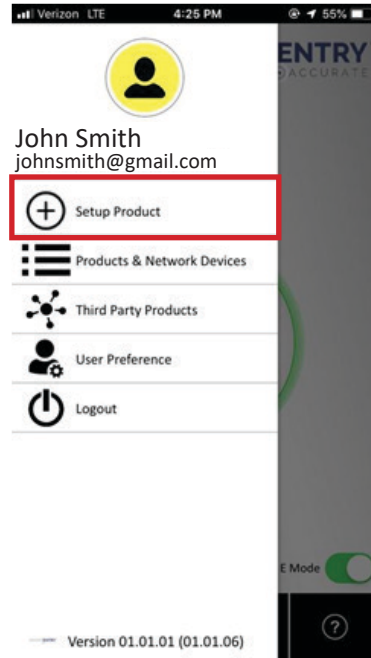

2/7

- Select the Setup Product option from upper left corner slider menu.



3/7

- Select SmartEntry Lock from product list.



4/7

- Review these links for proper installation information.

**GETTING STARTED: SET UP PRODUCT (continued)**

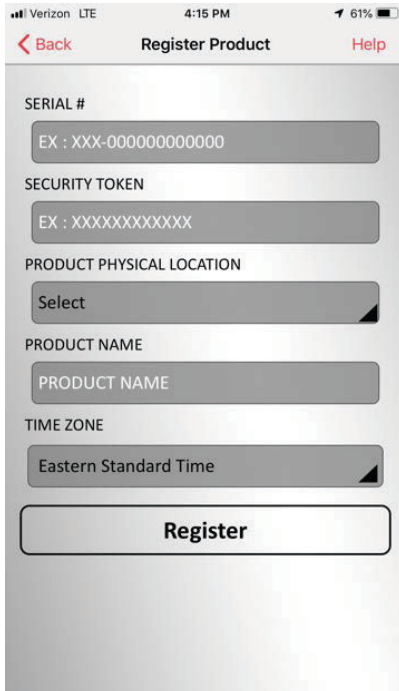

5/7

- Select your SmartEntry Lock from the list by its serial number.
- If your device is not showing, add it by scanning its QR code or enter it manually. (QR code label will be in the package the lock comes in)

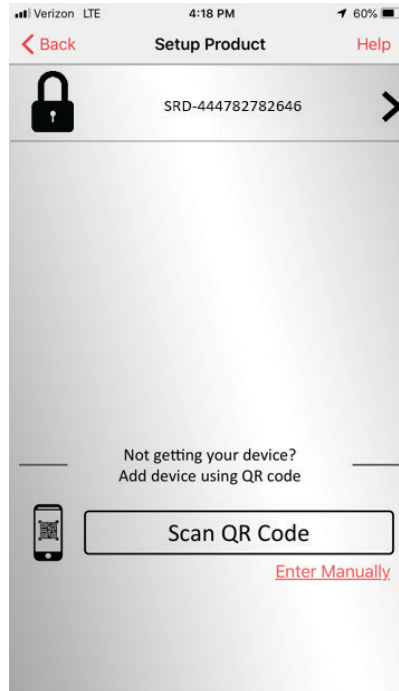

6/7

- After successful registration, you will see the home screen of the app.

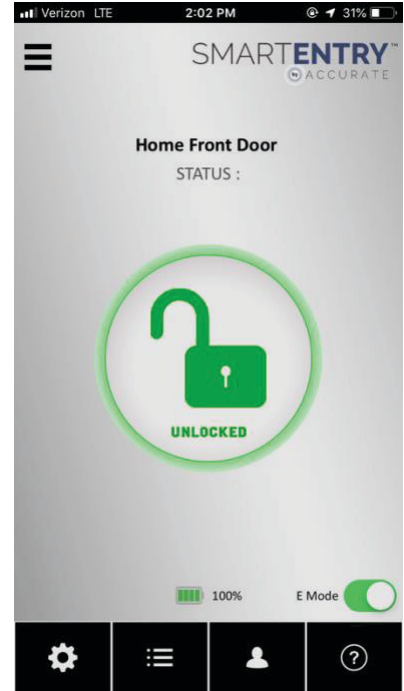

7/7

- Choose Product Physical Location from the list or you may give the location a name by selecting the Other option.
- Choose Product Name (Lock Name) from the list or you may give your choice of name by selecting Other option.
- Select Time Zone of the lock. This is required for user schedules.

## GETTING STARTED: TRANSFER OWNERSHIP

This is only necessary when an installer downloads the app and installs the SmartEntry lock on his/her phone (not the homeowner's phone). Additionally, these steps can be followed if the existing homeowner needs to transfer ownership to a new homeowner.

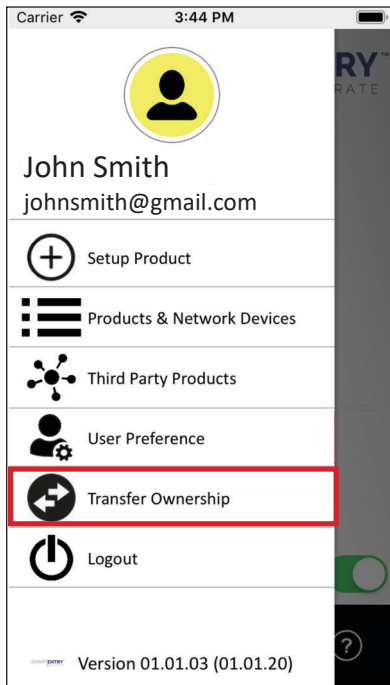

1/6

- Select Transfer Ownership from drop down menu.

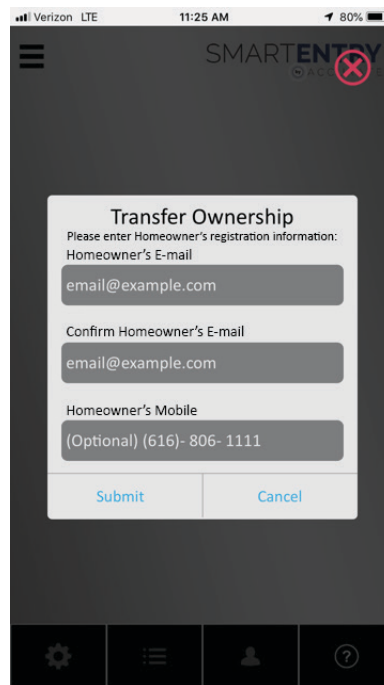

2/6

- Enter homeowner's registration information as required.

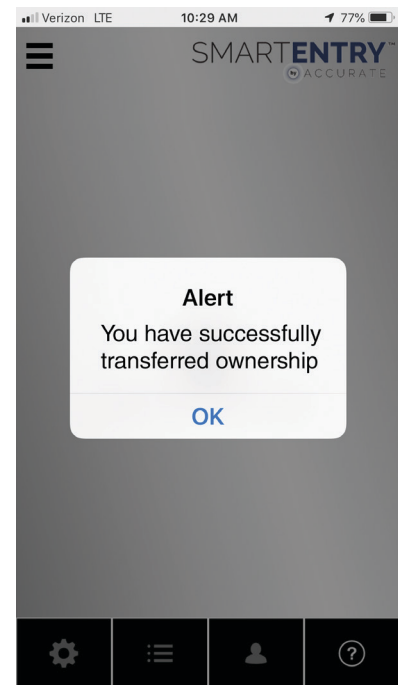

3/6

- Homeowner will be notified via contact information provided and will be prompted to download app and create an account.



## GETTING STARTED: TRANSFER OWNERSHIP (continued)

In the event the homeowner's contact information was entered incorrectly by the installer, or needs to be updated, this can be edited prior to the ownership transfer.

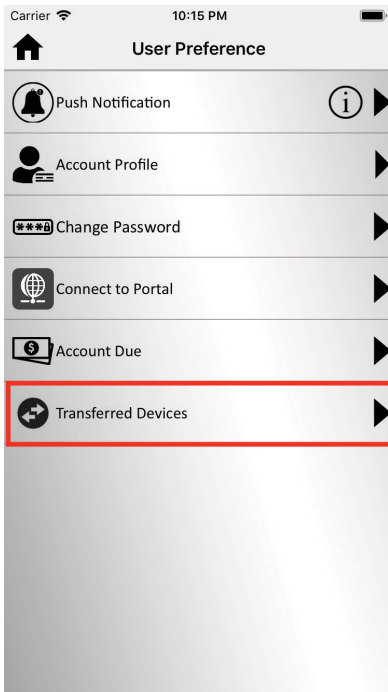

1/6

- Select Transferred Devices from the User Preference menu.

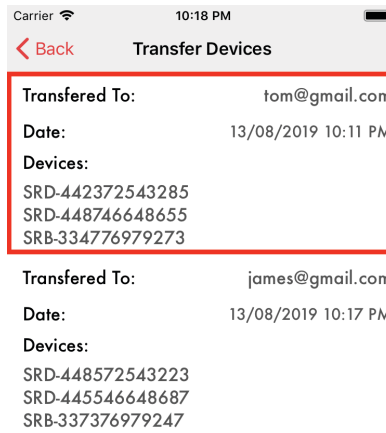

2/6

- Select appropriate record from the list.

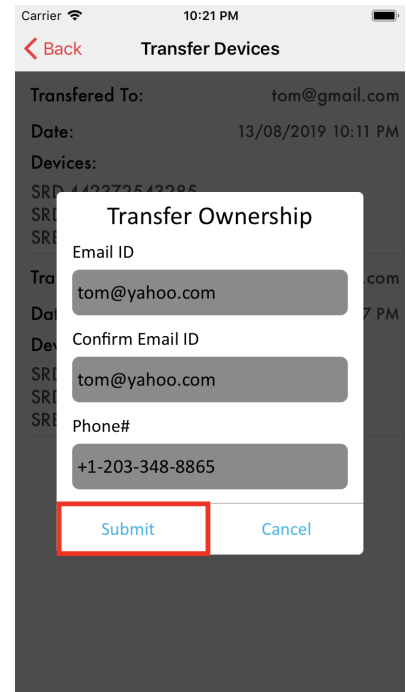

3/6

- Correct email add/or mobile number and then click submit.

## GETTING STARTED: ENTER PAYMENT

Once the installer has transferred ownership, the homeowner will be notified via email and SMS (when applicable) and be asked to download the app and create an account (per steps on page 4).

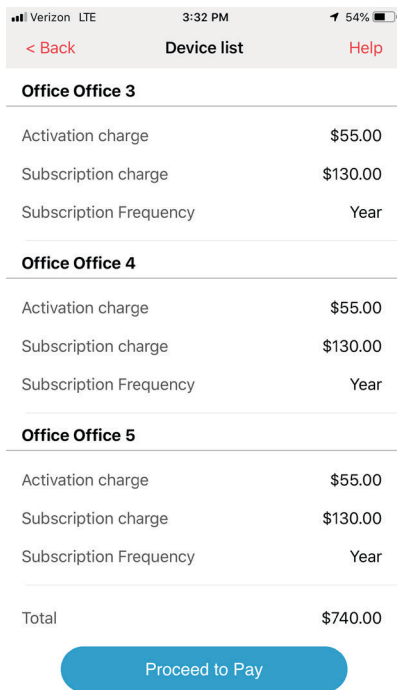

1/3

- Review payment requirements.

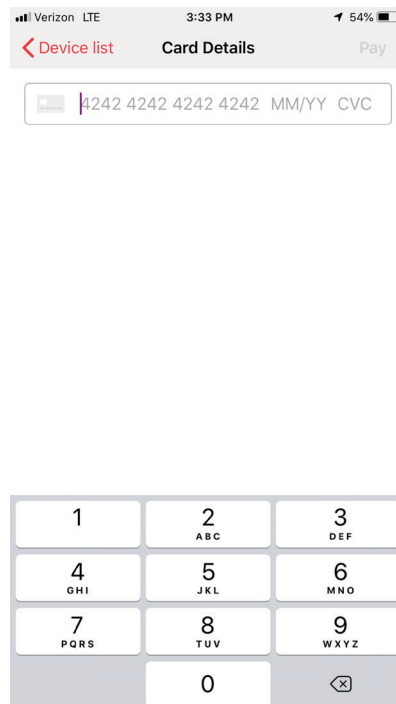

2/3

- Enter payment information and submit.

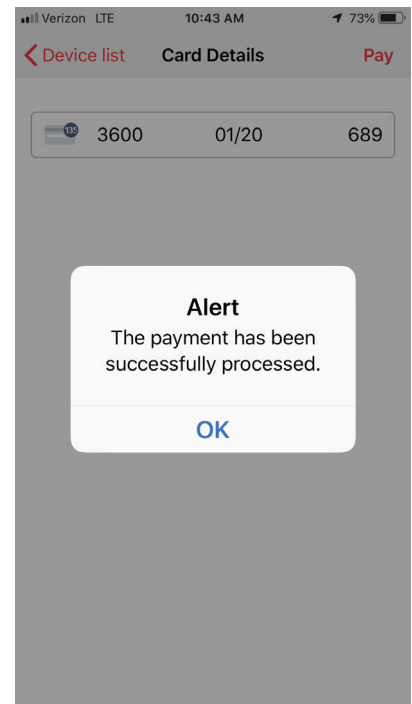

3/3

- Once payment has been completed, the SmartEntry Lock is ready for use.

## SMARTENTRY APP: FEATURES + FUNCTIONS

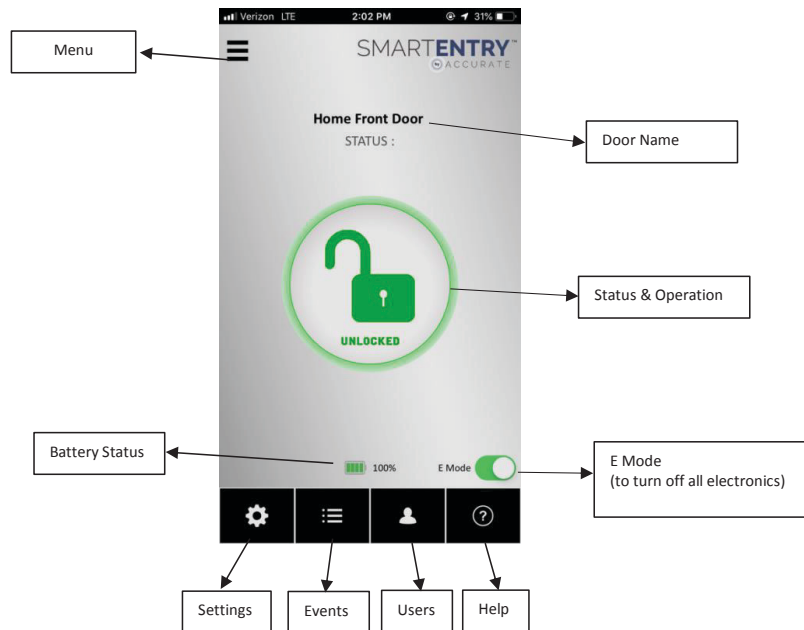

Menu	This menu provides options for third party product integration, user preferences and log out
Door Name	This is name given by Admin to the lock while setting up the product. This can be changed by tapping on it
Status & Operation	This shows current status of lock. Lock can be operated by tapping this button. Exclamation point (!) pops up above and to the right of the Status/Operation button indicating that latch is not fully extended and may mean that door is not closed.
Battery	Current battery status of the lock. We recommend changing it when battery life drops to 20%.
E Mode	Instantly turns off lock operation by phone, key fob or other electronic device. When this mode is set to off, outside handle automatically locks and stays locked. From the outside, the key is required for entry while on the inside the lever is always free for egress.
Settings	Device settings can be accessed or modified from here. This also has an option for Firmware Upgrades when available.
Events	All operations are recorded and can be viewed from here. More events can be viewed on portal by scrolling at end of page and tapping on option to view events on server.
Users	Easily allow access to friends and family in this section of the app. They can be scheduled to have access to operate at specific times and intervals.
Help	This section of the app offers user guides, FAQs, feedback, Submitting an issue and more.

## SMARTENTRY APP: CONTROL LOCK SETTINGS

SmartEntry lock provides different device settings which can be configurable per your needs.

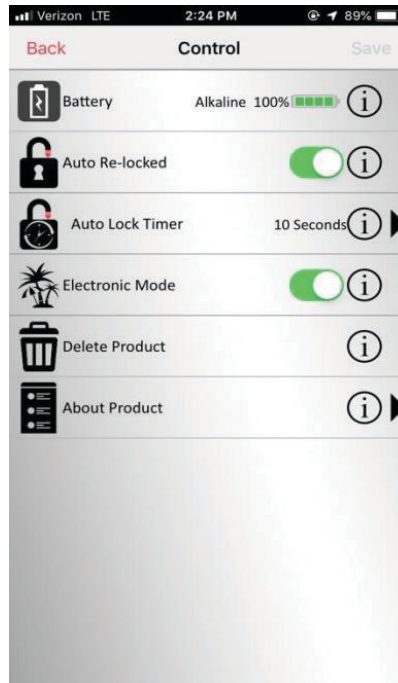

Battery	Battery type and current percentage is displayed.
Auto Re-locked	When Auto-Relocked is enabled, SmartEntry will relock door after you unlock it.
Auto Lock Timer	If Auto Re-locked is enabled, door will relock after this time. The timer value can be changed.
Electronic Mode	Instantly turns off lock operation by phone, key fob or other electronic device. Key required to gain entry from outside.
Delete Product	Deletes the product from account and device will be factory reset. It is desirable that you stay in Bluetooth range of the lock while deleting in order to delete fob users.
About Product	This option has details about SmartEntry Products and other options explained in next section.
Transferring Ownership	Provides details of how to transfer ownership from one party to another.

**SMARTENTRY APP: ABOUT PRODUCT**



Product Name	This is name that you give to your SmartEntry lock. This can be edited in this section of the app or you may also change it from home screen by tapping on the Product Name.
Set Location	You may set location of the product manually from here. Note that location is automatically set while setting up the lock.
Firmware Upgrade	Whenever new firmware is available, it can be upgraded from here. This requires connection via Bluetooth.
Factory Reset	If you want to reset lock as factory default, then click here. Caution: This will erase all settings and users.
Device Information	Device Serial Number, Hardware Version, Software Version

## SMARTENTRY APP: EVENTS

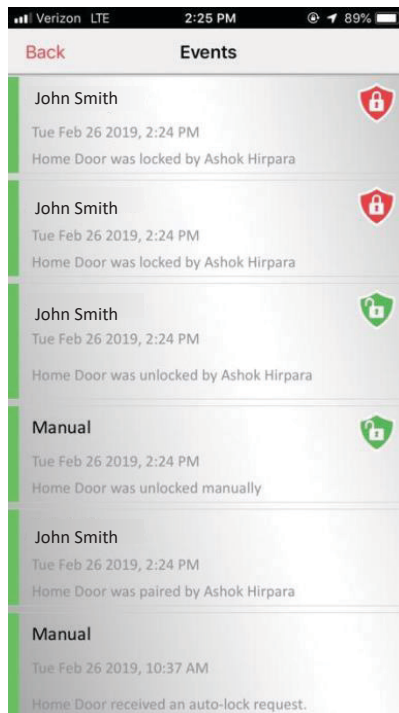

This section keeps a log of those who electronically accessed SmartEntry with corresponding time stamps. The app shows recent list of events. When you click on **Tap Here to See More Events**, app will take you to **SmartEntry Portal** where you can see a list of all events. The portal can also be accessed through <https://portal accuratelockandhardware.com>.

## SMARTENTRY APP: USER MANAGEMENT

Keep Bluetooth on and stay in range.

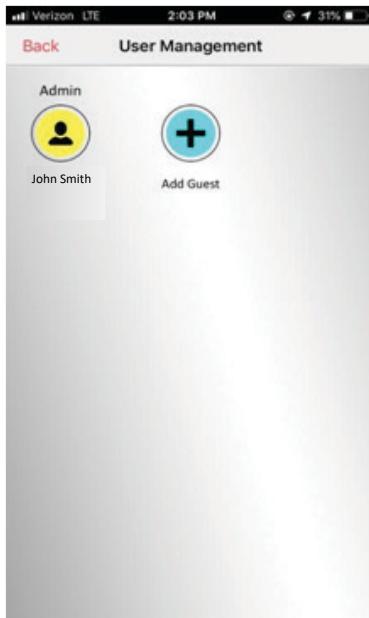

1/4

- Inviting friends and family to access the lock is easy. Users can be scheduled to operate during specific times and days.



2/4

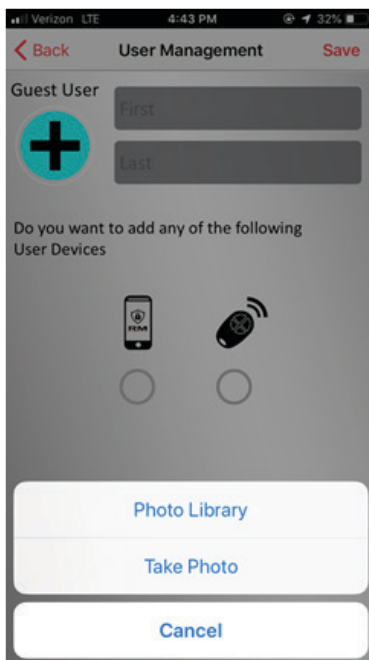

3/4

- By clicking on + sign, you can add a profile picture of the user.

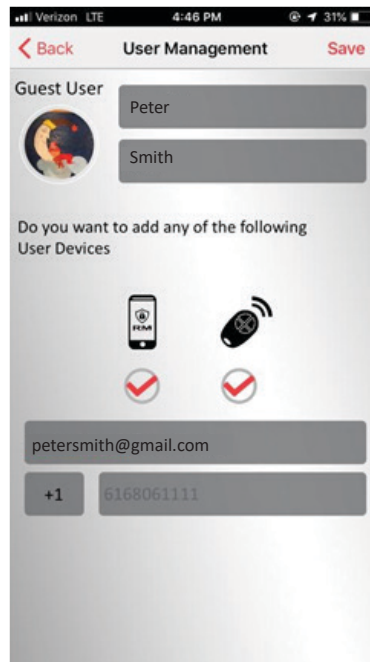

4/4

- Select Devices you want to give access to
- When you select mobile, you must provide email address and guest user to create an account with this same email address.

## SMARTENTRY APP: USER MANAGEMENT

Keep Bluetooth on and stay in range.

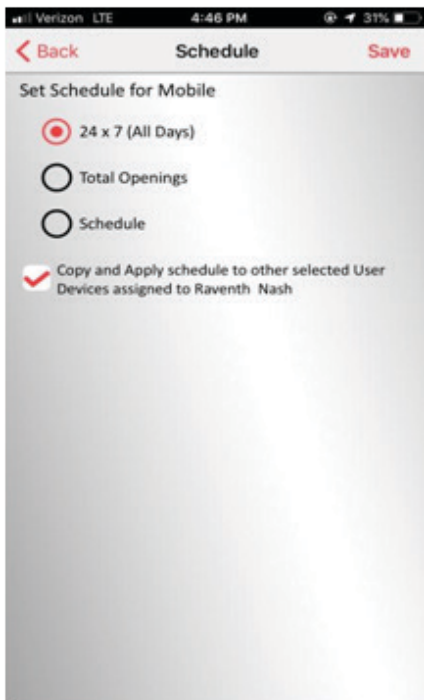

1/6

- Select the schedule for guest user
- You may provide 24/7 access to guest user
- Select Schedule and mark the bottom checkbox if you want to use same schedule for all user devices for this user

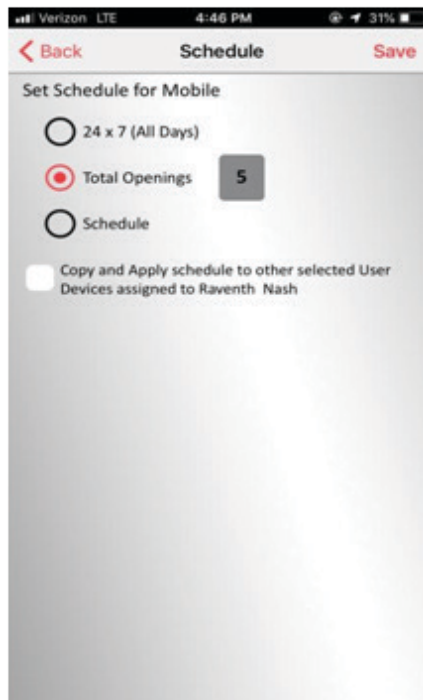

2/6

- You may set user to operate SmartEntry a limited number of times.

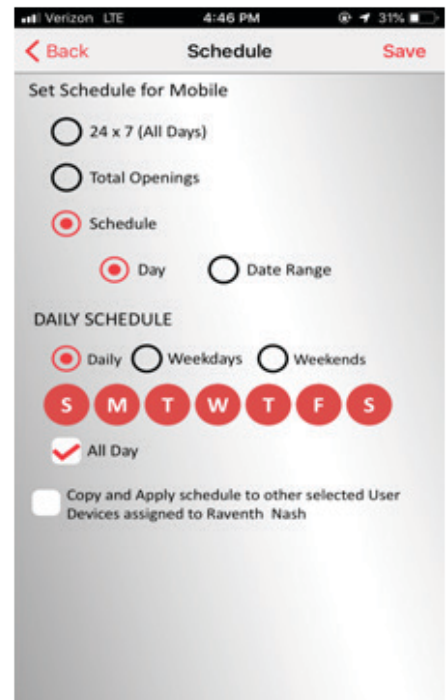

3/6

- You may set a user to operate all day or specific times a day.



## SMARTENTRY APP: USER MANAGEMENT (continued)

Keep Bluetooth on and stay in range.

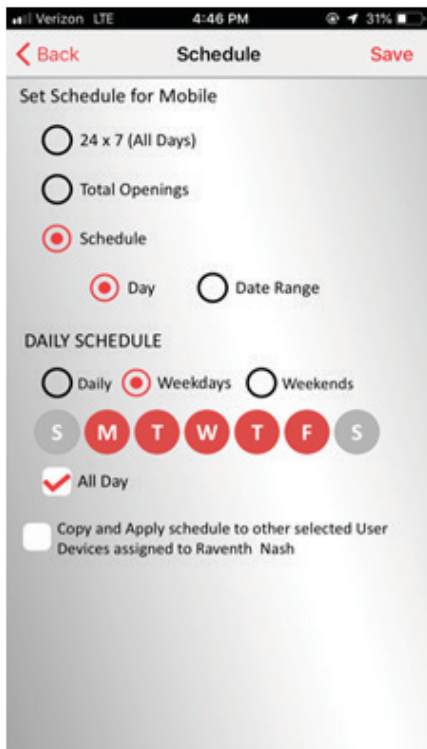

4/6

- You may set a user to operate on week days or just weekends.

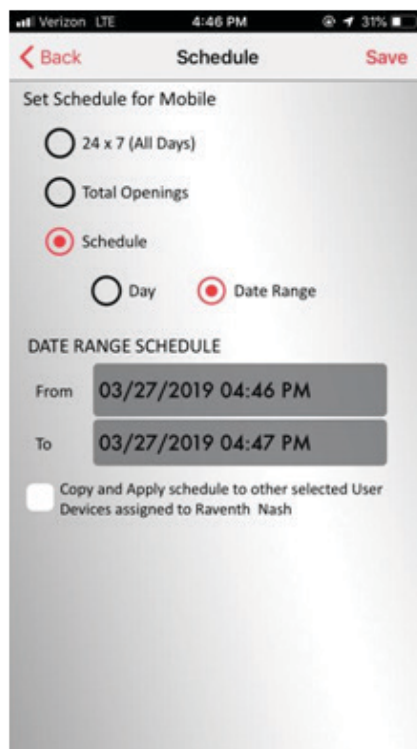

5/6

- You may schedule a user's access for specific date duration



6/7

- Upon tapping Save, the app will start User Registration process.

**SMARTENTRY APP: EDIT A SCHEDULE**

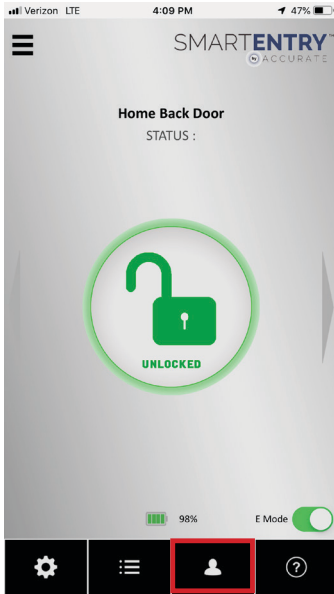

1/5

- Select the User Management on bottom menu.

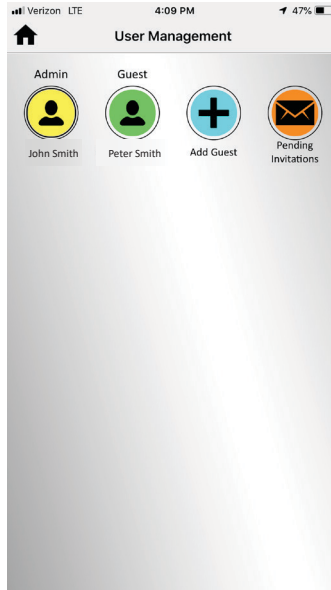

2/5

- Select appropriate user to edit access schedule.

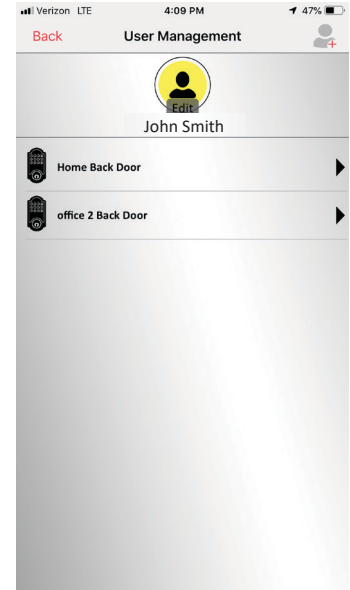

3/5

- Select the SmartEntry device you would like to edit.

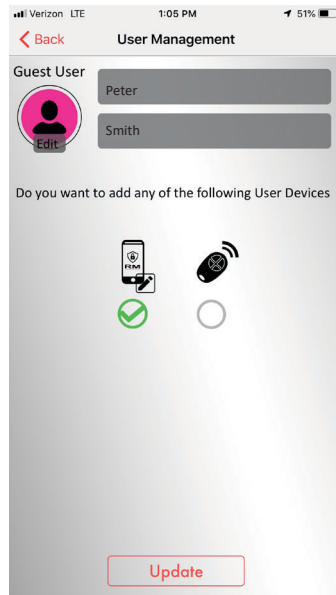

4/5

- Select phone icon and click update.

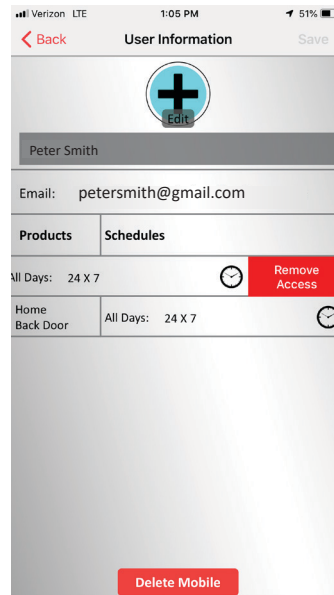

5/5

- In the user's profile, you can edit the schedule by tapping the clock icon, or swiping left to delete all access.

SMARTENTRY APP: ADDING A KEYFOB

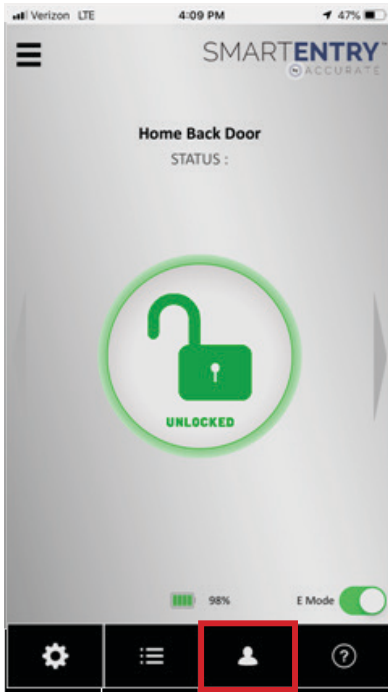

1/8

- Select the User Management on the bottom menu.

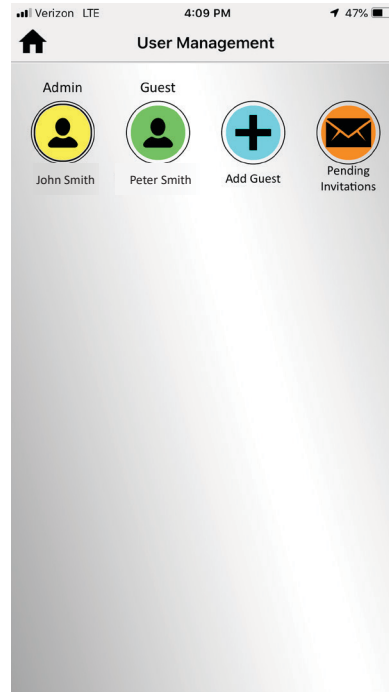

2/8

- Select appropriate user to assign keyfob to.

Note: Keyfob access can be scheduled the same way phone access can, see page 15.

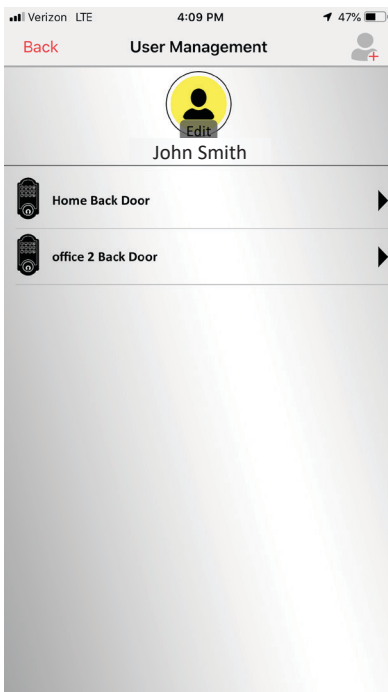

3/8

- Select the SmartEntry device you would like to configure with the keyfob.

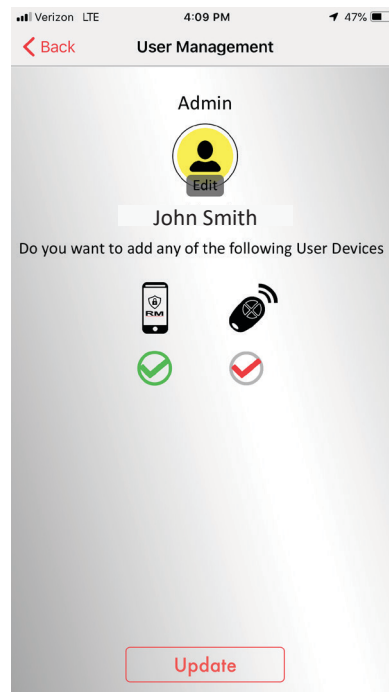

4/8

- Select keyfob and click update.

SMARTENTRY APP: ADDING A KEYFOB (continued)

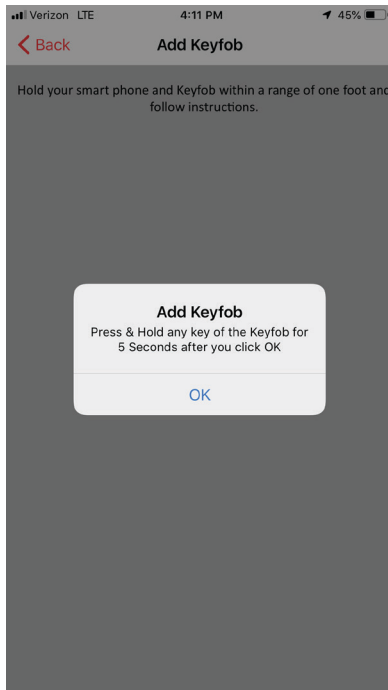

- 5/8
- Add Keyfob by clicking OK.

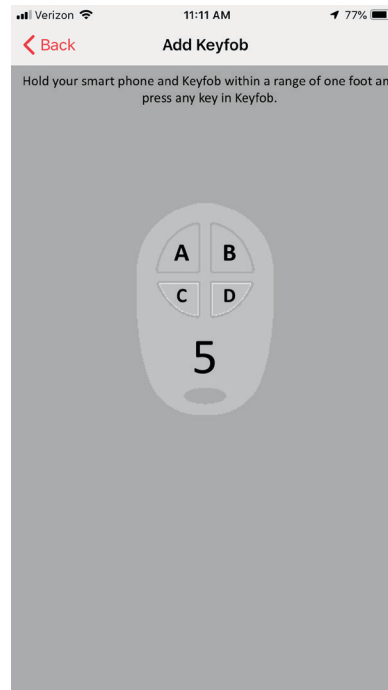

- 6/8
- Press and hold any key on the keyfob to start the configuration process and there will be a countdown on the screen.

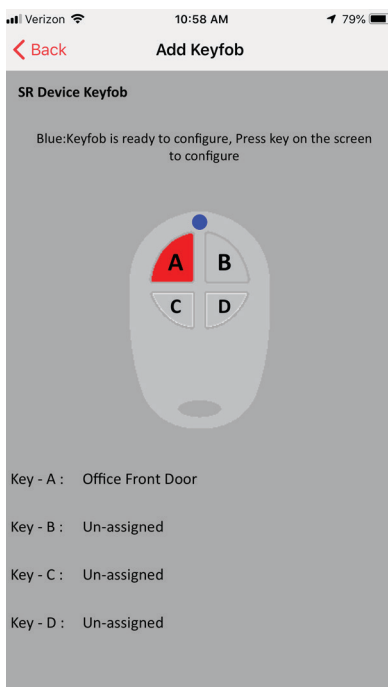

- 7/8
- All keys will be listed with their current assignment of the lock. Tap the desired available key on the image of the keyfob on screen to assign device. You can choose any available key from the list. If you choose a key that is already assigned to a lock, it will be overridden with new assignment.

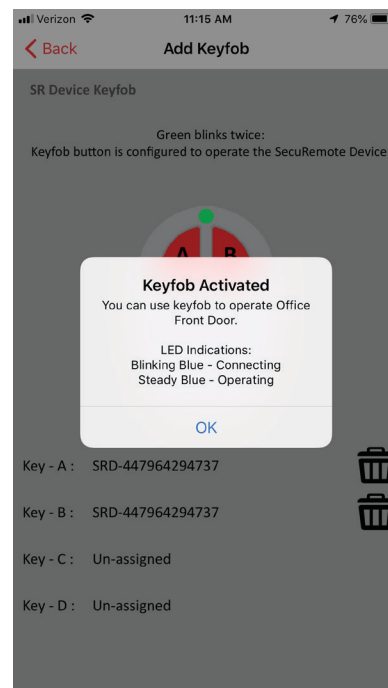

- 8/8
- Once you select the key and Fob will be ready to operate lock.

## SMARTENTRY APP: EDITING KEYFOB USERS

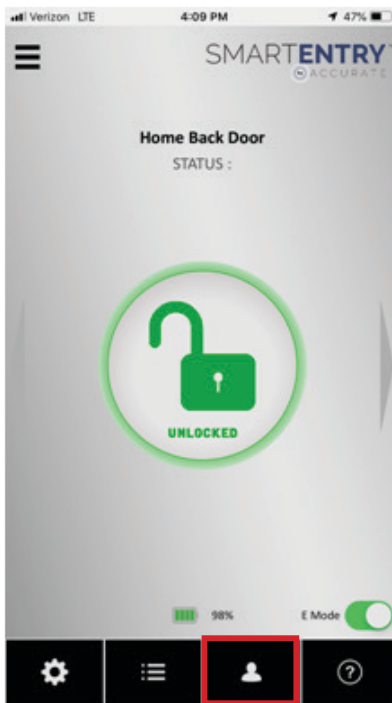

1/6

- Select the User Management on the bottom menu.

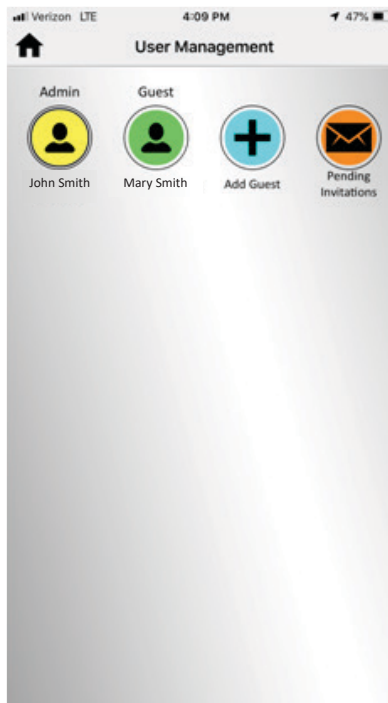

2/6

- Select appropriate user to assign keyfob to.

Note: Keyfob access can be scheduled the same way phone access can, see page 15.

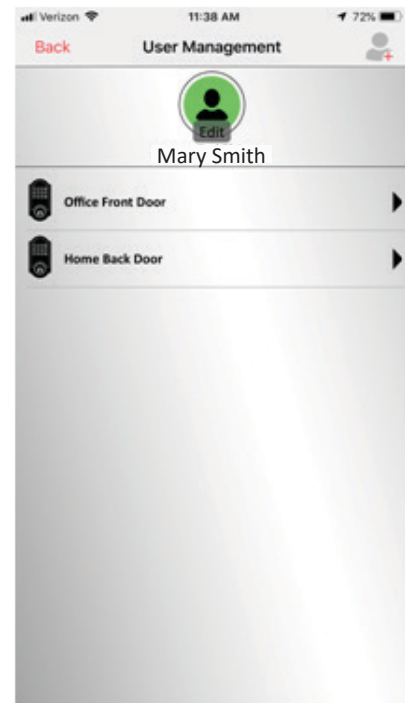

3/6

- Select the user and SmartEntry device to edit.

SMARTENTRY APP: EDITING KEYFOB USERS (continued)

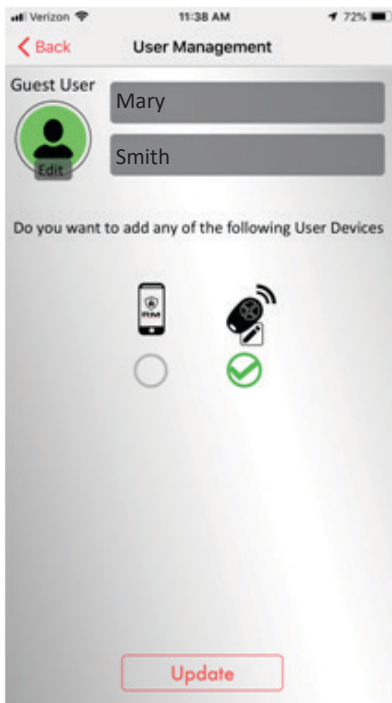

4/6

- Select pencil icon next to the keyfob.

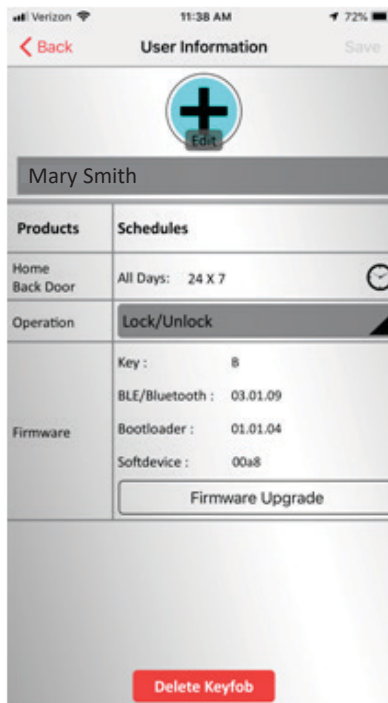

5/6

- Select Delete Keyfob.

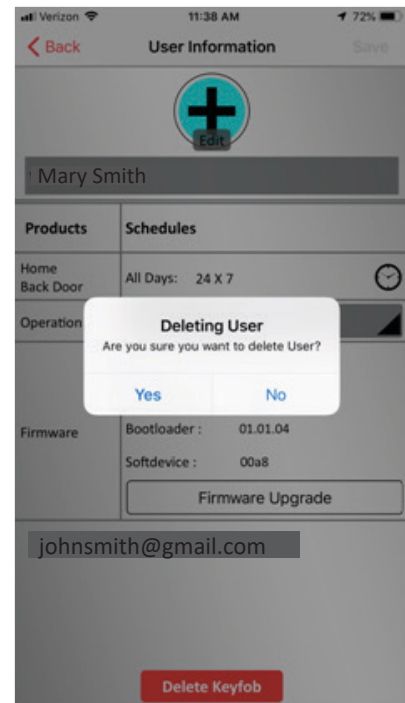

6/6

- A warning message will pop up, select Yes. Note: this will only delete the user's keyfob from the device.

## SMARTENTRY APP: ADDING A KEYPAD

After installing the keypad, make sure the phone app is closed when using. Per standard Bluetooth operation, only one device can operate the lock at any given time. The app can be open in the background but it cannot be opened on the phone screen when operating the keypad.

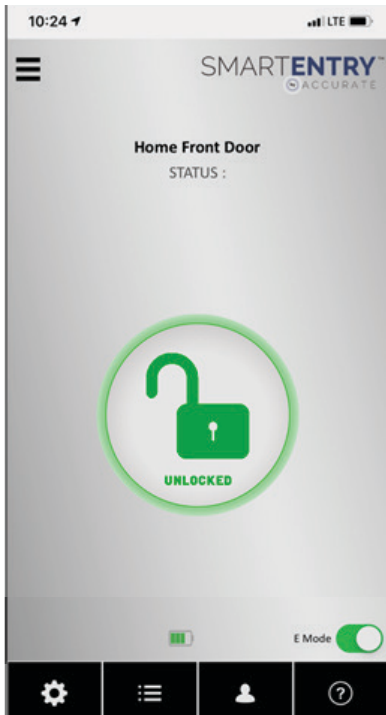

- 1/8
- Select the User Management on the bottom menu.

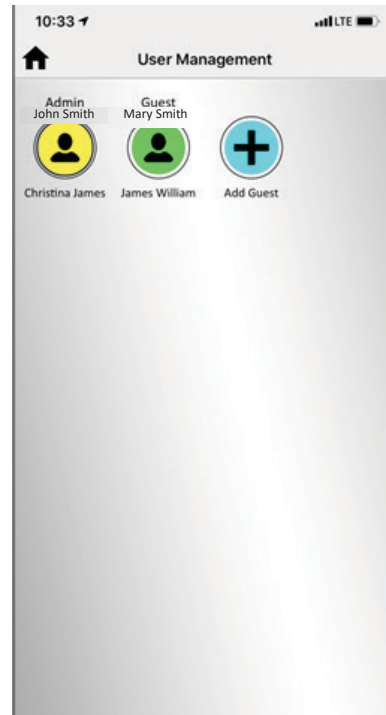

- 2/8
- Select Admin from the list

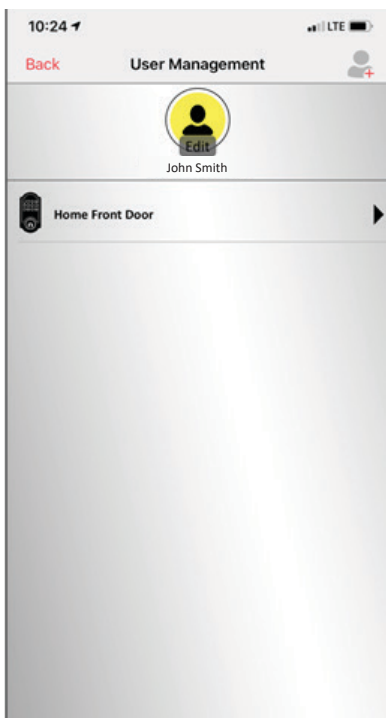

- 3/8
- Select the SmartEntry device you would like to configure with the keypad.

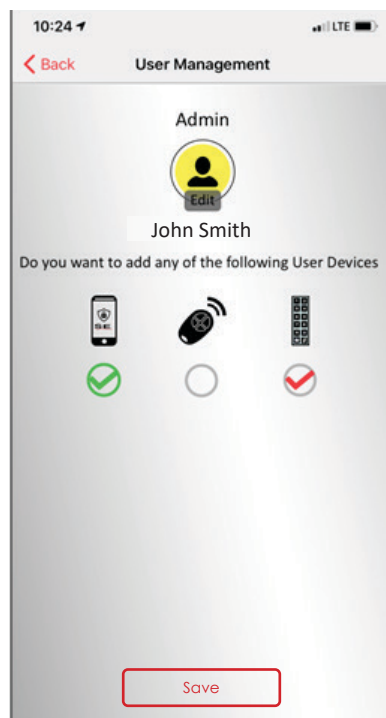

- 4/8
- Select keypad and click SAVE.

**SMARTENTRY APP: ADDING A KEYPAD (continued)**

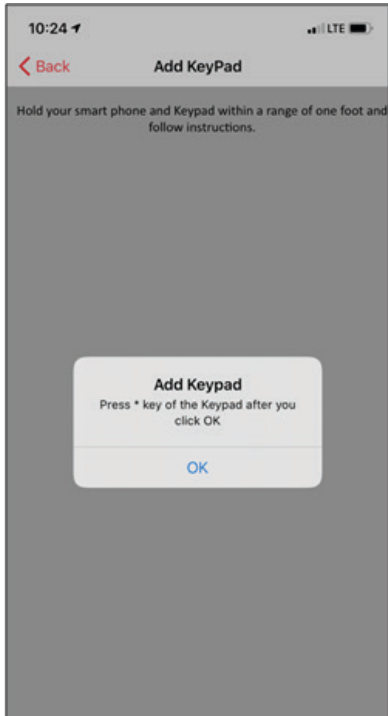

**5/8**

- Tap OK and then press \* on the keypad

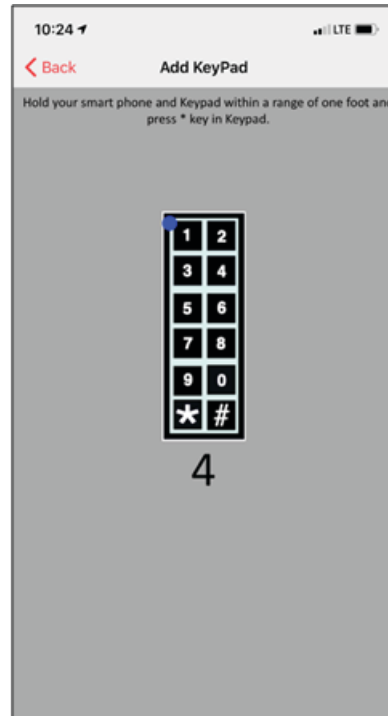

**6/8**

- The app will find the nearby keypad and will start configuration process

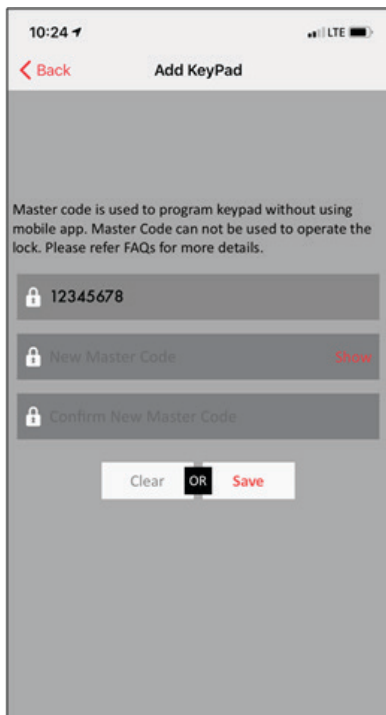

**7/8**

- Change the Master Code of the keypad. (This will be used for the keypad settings change)

**Master Code must be a minimum of 8 digits.**

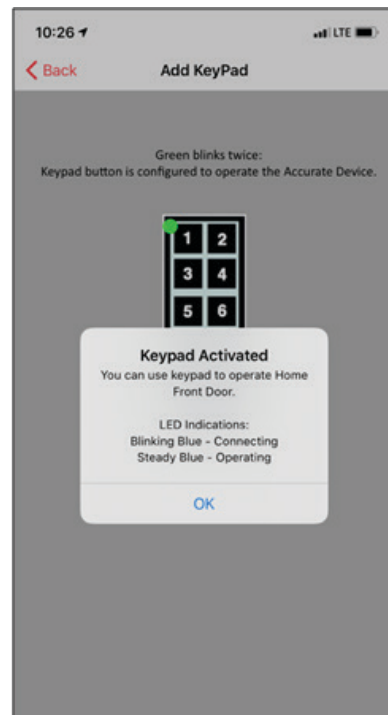

**8/8**

- Once the keypad is ready, the app will show confirmation.



## SMARTENTRY APP: ADDING KEYPAD USERS

Once the keypad is associated with the SmartEntry lock, the app will show the option to add a keycode in user management. You can add a keycode to existing user or create a new user.

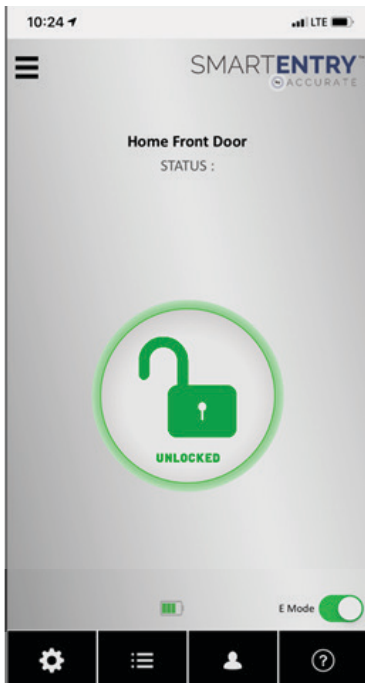

- 1/4**
- Select the User Management on the bottom menu.

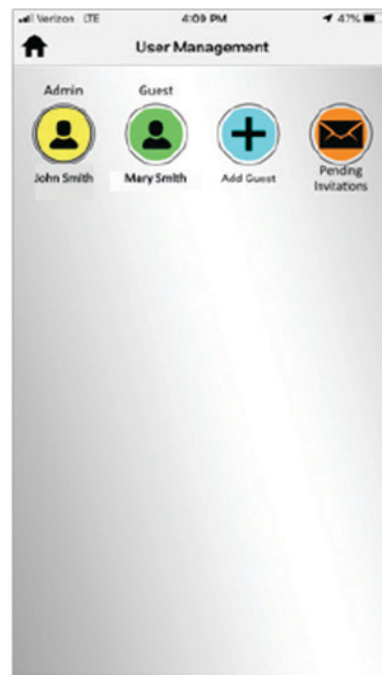

- 2/4**
- Select appropriate user to assign keypad to, or press "+" to add a new user.

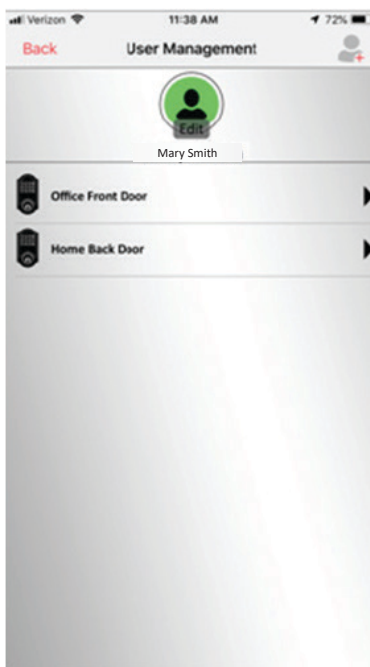

- 3/4**
- Select the user and SmartEntry device to edit.

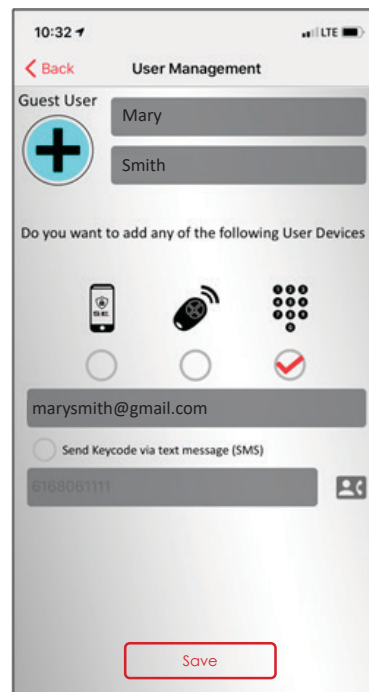

- 4/4**
- Select the keypad icon and assign a 4 digit code.
- Note: Keypad access can be scheduled the same way phone access can, see page 16.

## SMARTENTRY APP: EDITING KEYPAD USERS

After installing the keypad, make sure the phone app is closed when using. Per standard Bluetooth operation, only one device can operate the lock at any given time. The app can be open in the background but it cannot be opened on the phone screen when operating the keypad.

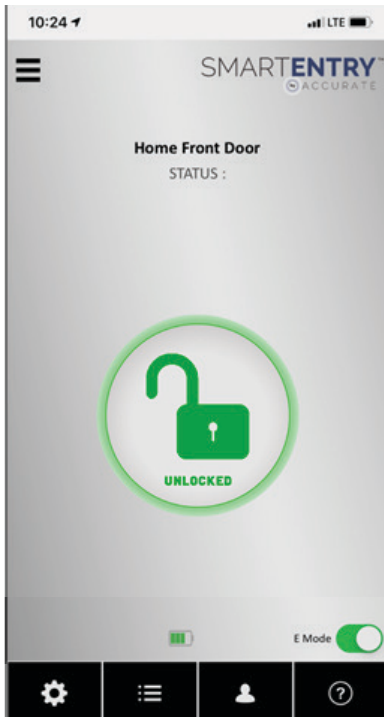

- 1/4
- Select the User Management on the bottom menu.



- 2/4
- Select appropriate user to edit.

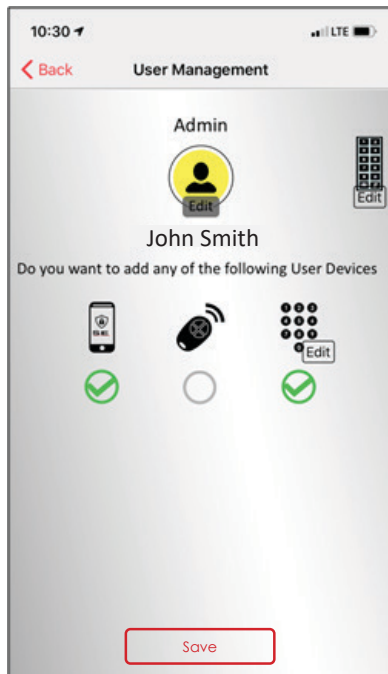

- 3/4
- Notice the keypad icon beside the user name. Click on EDIT on the keypad icon below.

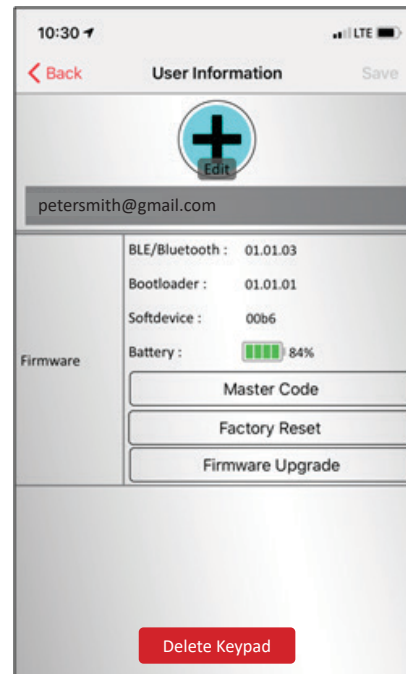

- 4/4
- Change current Master Code, upgrade the firmware or factory reset the keypad.

## SMARTENTRY APP: KEYPAD LED INDICATIONS

Accurate Keypad has LED (light) indications and buzzer indication to notify different situation. You may refer this table for more detail.

Description	Blue	Green	Red	White	Cyan	Yellow	Magenta	Buzzer
Power ON	Blink Once	Blink Once	Blink Once	Blink Once				Once
Firmware Upgrade Mode					Blinking			
Bluetooth Connection on Firmware Upgrade Mode	Solid							
Looking for Bluetooth Connection	Blinking							
Bluetooth Connection Is On	Solid							
Unlock		Solid						Once
Error while Unlocking			Solid					Once
Programming Code has to be changed					Blink Twice			Twice
Keycode user is not added to lock							Blink Twice	Twice
User is disabled				Solid				Once
Lock is disabled					Solid			Once
User does not exist							Solid	Once
User is not allowed to operate this time						Solid		Once
Pass Code mismatch			Solid					Once
Operation failed			Solid					Once
Key Pressed		Solid						Once
Low Battery			Solid (When Key is Pressed)					Once
Configuration Key Pressed								Once
Configuration Completed					Solid			Once
BLE Discovery Fail							Blinking	
Error while Configuring			Blinking					

## SMARTENTRY APP: OPERATE/PROGRAM USING KEYPAD

Once the keypad is added to your account, these functions are available from keypad.

### TO OPERATE:

Operation	Command
Unlock	User Code (4 digits)

### TO CHANGE SETTINGS:

Settings	Command	Notes
Change Programming/ Master Code	*FC*10*8-digit New Programming (master) code #	Note: Once Programming is set, Factory pre-set code will not work
Add user code (limit 49 user codes)	*Programming (Master) Code*20*(4 digits user code) #	Cannot add schedule when adding user code using keypad.
Delete user code	*Programming (Master) Code *30*(4 digits user code) #	Delete user code using actual user
Configuration Mode	Press *	Keypad Will start advertising for configuration mode.
Factory Reset	*Programming (Master) Code*40#	Programming code Default

## SMARTENTRY APP: HARDWIRING INSTRUCTIONS

SmartEntry by Accurate offers the option to be hardwired. Polarized leads (red positive, black negative) requires 24VDC power. The CPU can be hardwired and simultaneously have battery power for backup. The system will default to using power from the hardwire when both are connected.

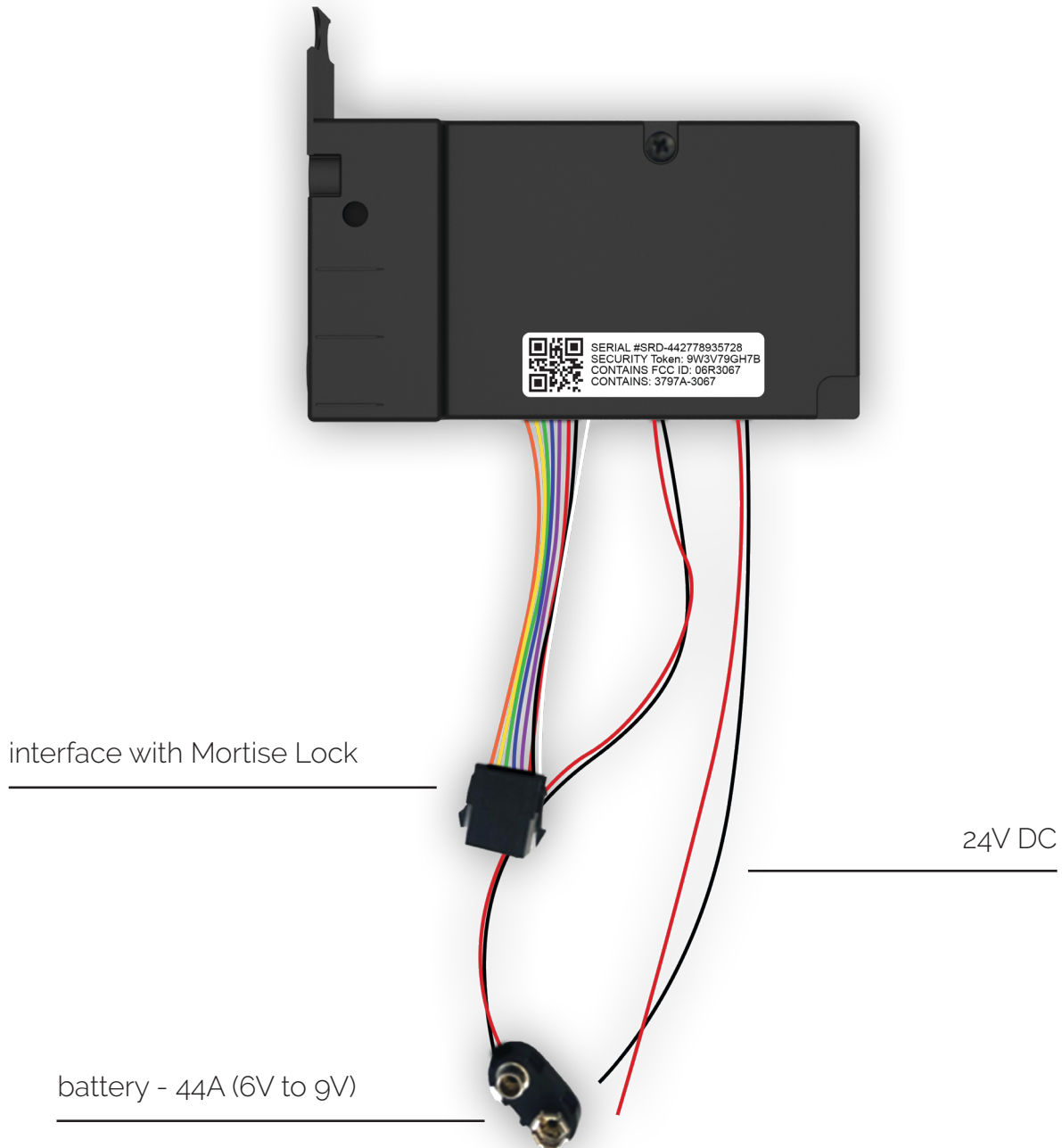

**SMARTENTRY APP: HELP CENTER**

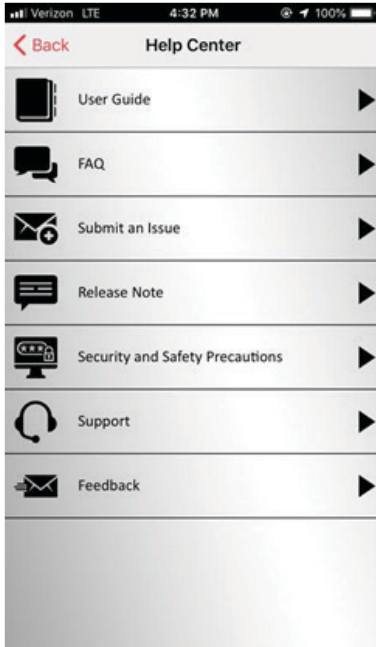

**1/4**

- Help Center provides options to troubleshoot problems or contact support.

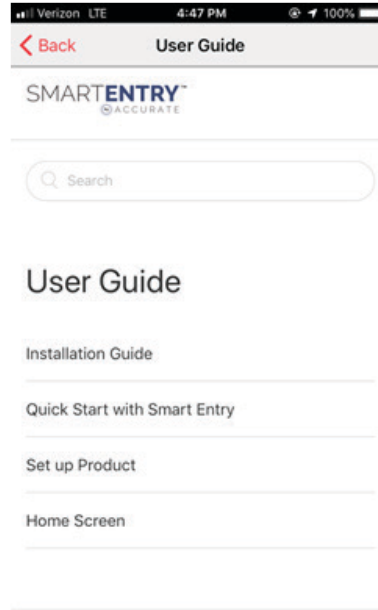

**2/4**

- User Guide includes: Installation Instructions, Quick Start Guide, and more.

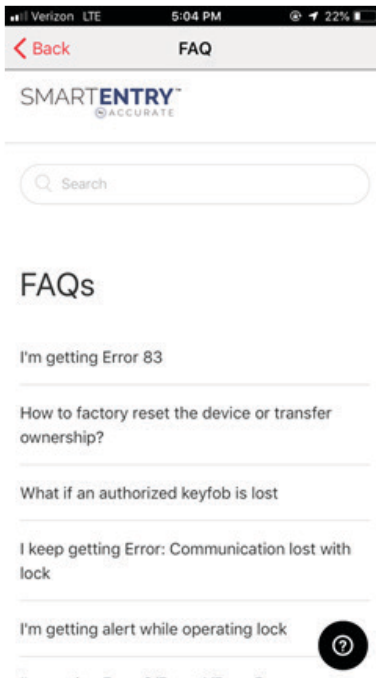

**3/4**

- Explore Frequently Asked Questions and Answers.

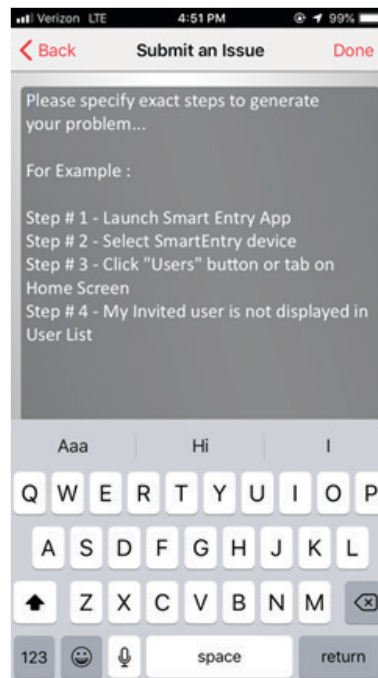

**4/4**

- If you run into a problem, tap on Submit an Issue, provide brief description and tap "Send".

**SMARTENTRY APP: MENU**

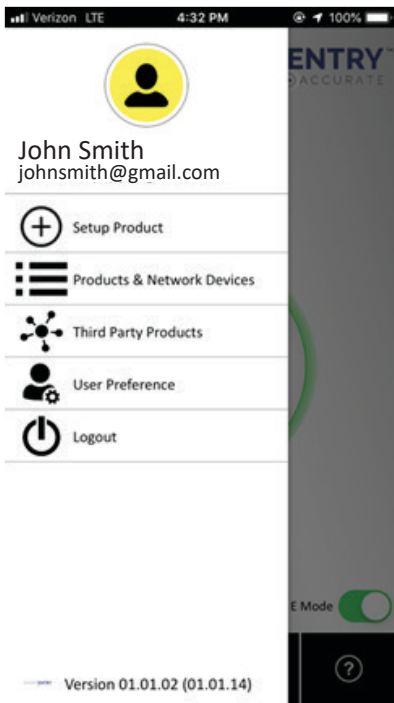

1/6

- The upper left corner with three bars is the menu.
- Tap to reveal your name, email address and product setup information.

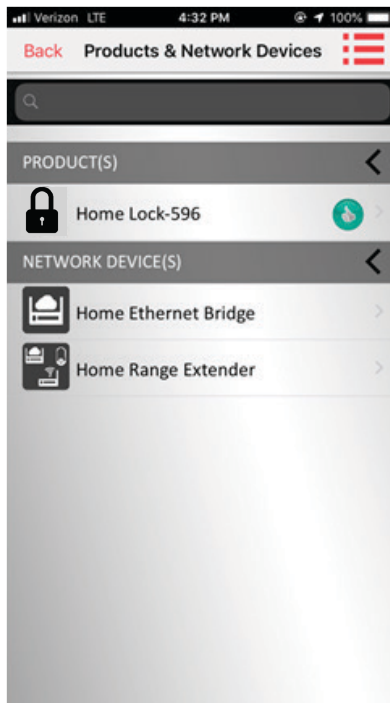

2/6

- Here you can find the list of Products in your account.

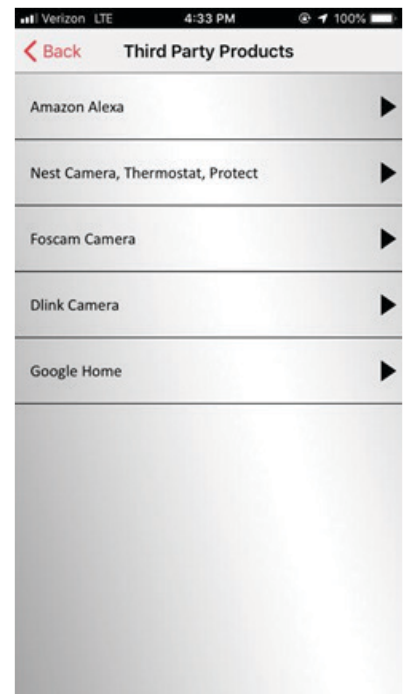

3/6

- Support of third-party products integration can be done from here.

**SMARTENTRY APP: MENU (continued)**

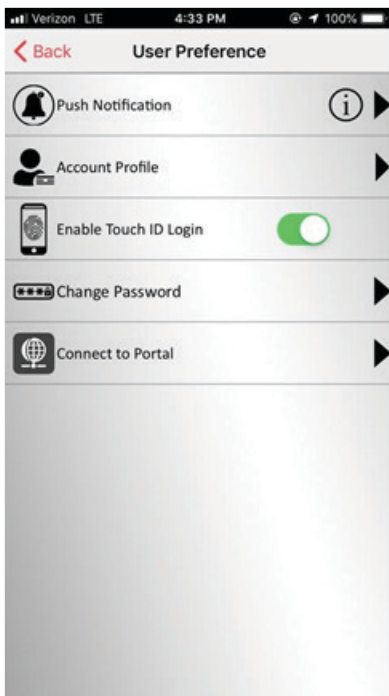

4/6

- User Preference includes app related settings.

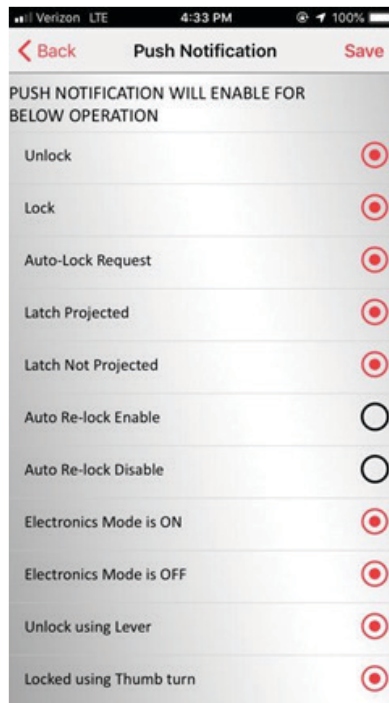

5/6

- Notifications can be received for the events which are subscribed for this lock.



6/6

- Account Profile and picture can be updated here.



## SMARTENTRY ETHERNET BRIDGE

### PACKAGE CONTENTS

- + SmartEntry Ethernet Bridge
- + Ethernet Cable (3 feet long)
- + BLE Antenna
- + Power Supply 5V@1A
- + Product Information Label

### VERIFY PREREQUISITES

- + Install SmartEntry Lock app on smartphone
- + Register and add at least one SmartEntry Lock to your account

### LED Indications:

EVENT	RED	WHITE	BLUE
Power On	Blinks 3 times	Blinks 3 times	Blinks 3 times
Bluetooth Connection	-	-	Blinking
Connected with SmartEntry portal	OFF	OFF	OFF
Remote operation request is in process	-	Blinking	-
Remoteoperationcompleted	-	Solid for 3 sec	-
Ethernet Cable is unplugged	Solid	-	Solid
IP Address is not assigned	-	-	Solid
Bridge is not registered with SmartEntry portal	Blinking	-	Solid
Cannot communicate with SmartEntry portal	Blinking	-	-

## SMARTENTRY ETHERNET BRIDGE: PLUG IN + POWER UP

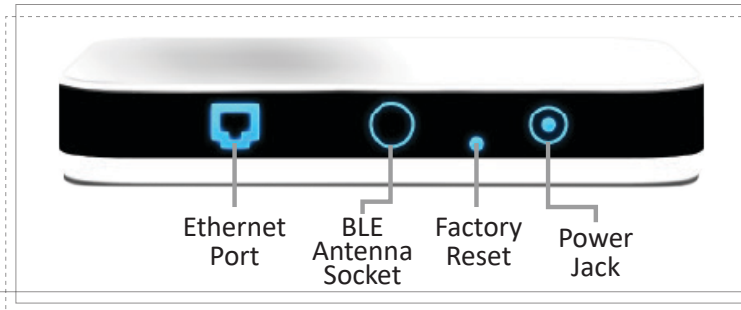

1. Fully tighten the BLE Antenna to the back of the Bridge, pivoting in the upright position.



2. Plug Ethernet cable into Bridge from your Internet Router.

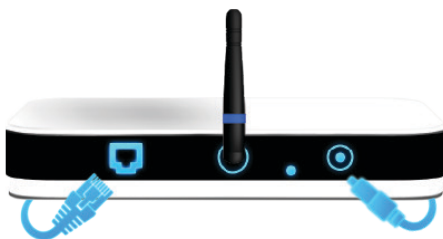

3. Plug the Power Jack end into the Bridge and the power adapter into a power outlet.

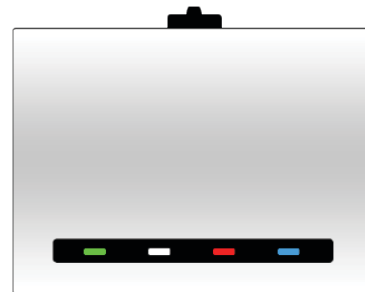

4. Verify the green LED in ON, see the LED chart\* if any other light blinks or remains solid.

\*LED chart is shown in the previous sheet

SMARTENTRY ETHERNET BRIDGE: REGISTER TO SERVER 1/2

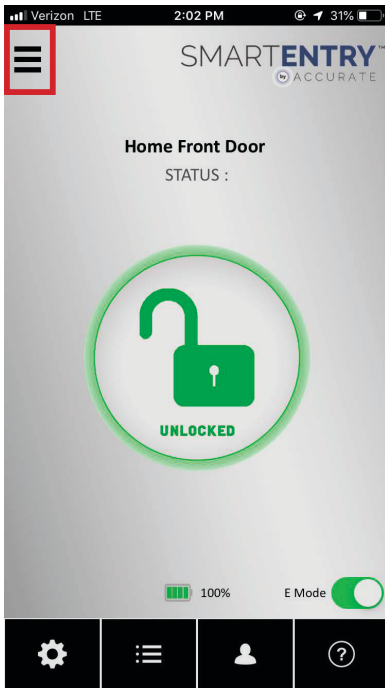

1/4

- Launch the SmartEntry app on smartphone.
- Click the **slider menu**.

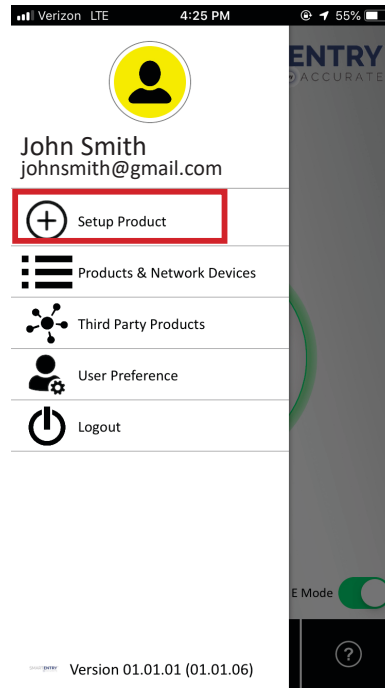

2/4

- Select **Setup Product** option.

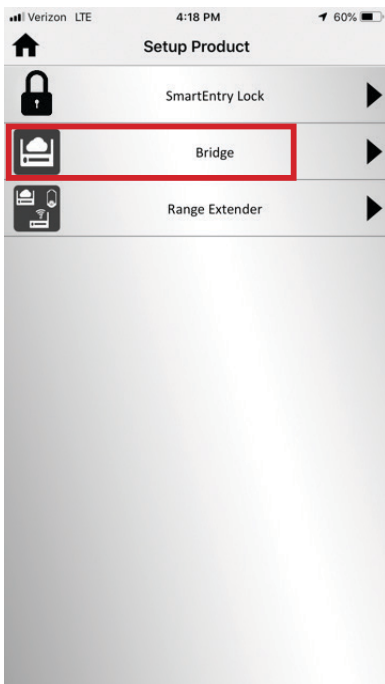

3/4

- Select **Setup Product** option

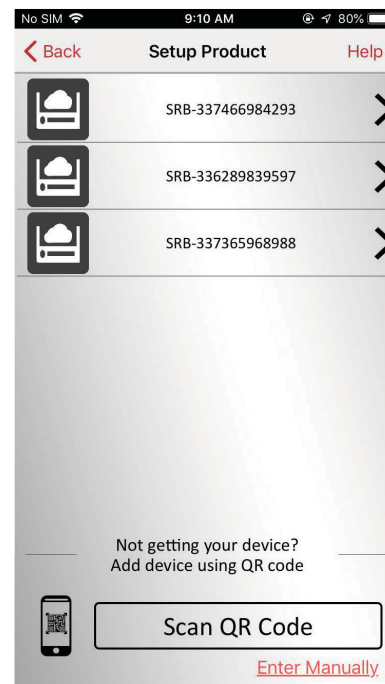

4/4

- Select your Bridge from the list.

SMARTENTRY ETHERNET BRIDGE: REGISTER TO SERVER 2/2

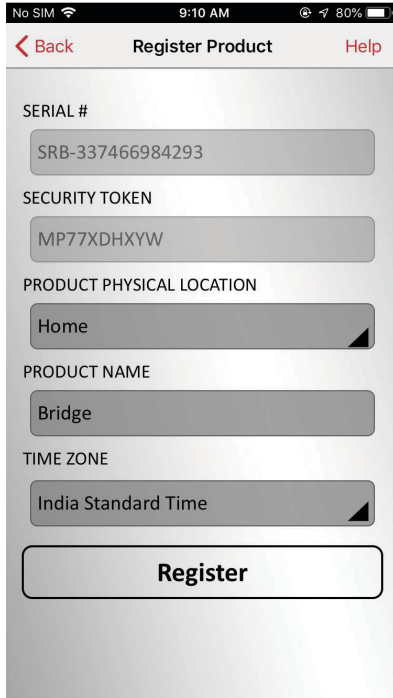

1/4  
• Provide **Name, Location, and Time Zone**

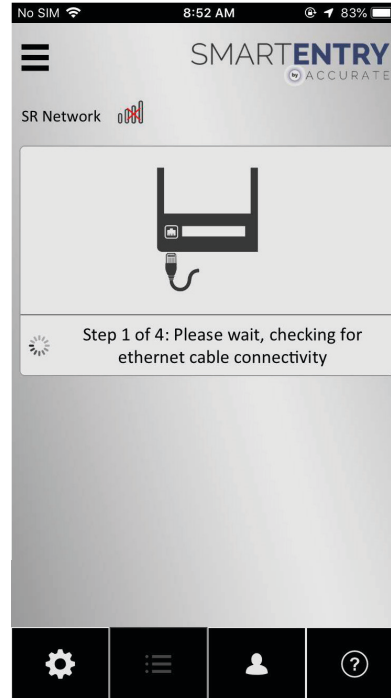

2/4  
• The Bridge will start the set up process.

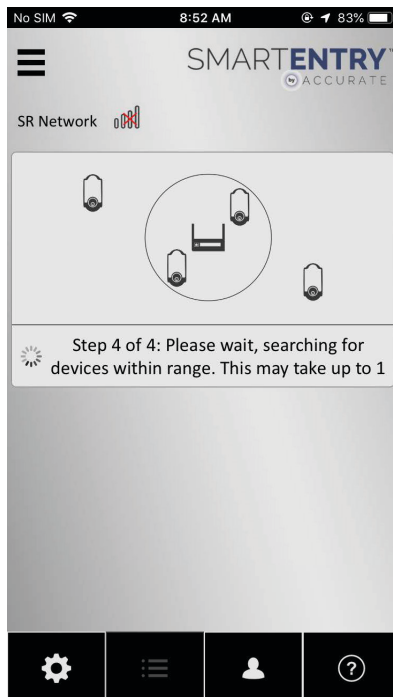

3/4  
• The Bridge will search nearby device and connect.

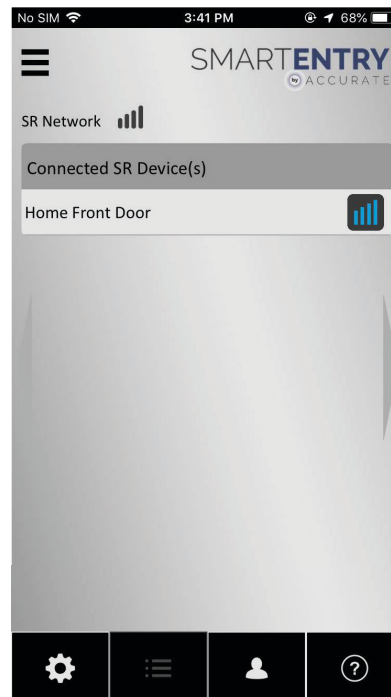

4/4  
• List of connected devices and their status.

## SMARTENTRY RANGE EXTENDER

### PACKAGE CONTENTS

- + SmartEntry Range Extender
- + BLE Antenna
- + Power Supply 5V@1A
- + Product Information Label

### VERIFY PREREQUISITES

- + Install SmartEntry Lock app on smartphone
- + Register and add at least one SmartEntry Lock to your account

### LED Indications:

EVENT	RED	WHITE	BLUE
Power On	Blinks 3 times	Blinks 3 times	Blinks 3 times
Bluetooth Connection	-	-	Blinking
Connected in network	OFF	OFF	OFF
Not Connected in network	-	-	Solid
Network request is in process	-	Blinking	-
Network request executed successfully	-	Solid for 3 seconds	-
Network request fail	Blinks for 3 seconds	-	-
Not getting Network ID from Smartphone	Solid	-	-

## SMARTENTRY RANGE EXTENDER: PLUG IN + POWER UP

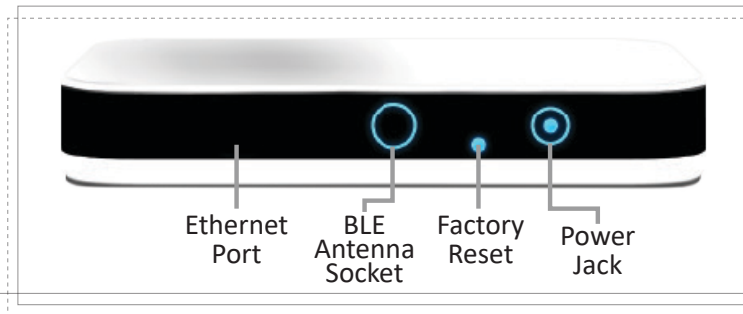

1. Fully tighten the BLE Antenna into the BLE Antenna socket in the back of the Range Extender and align in upright position.



2. Plug the power jack end into the Range Extender and the power adapter into a power outlet.

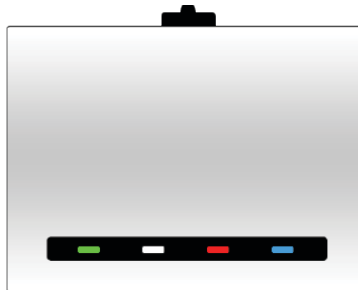

3. Verify the green LED is ON, see the LED chart\* if any other light blinks or remains solid.

\*LED chart is shown in the back of this sheet

SMARTENTRY RANGE EXTENDER:

REGISTER TO SERVER 1/2

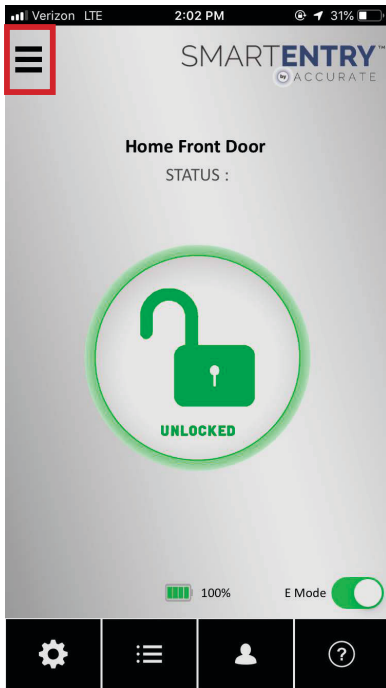

1/4

- Launch the SmartEntry app on smartphone.
- Click the **slider menu**.

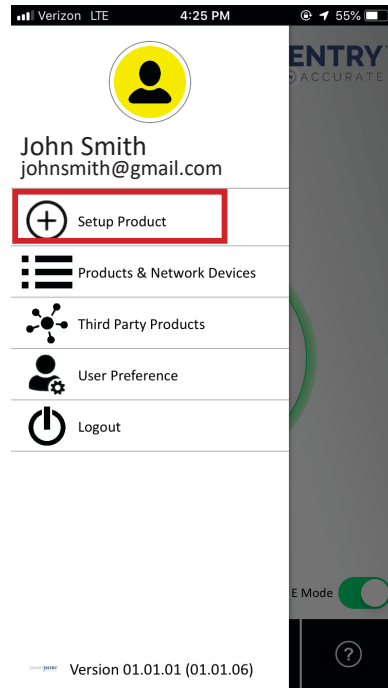

2/4

- Select **Setup Product** option.

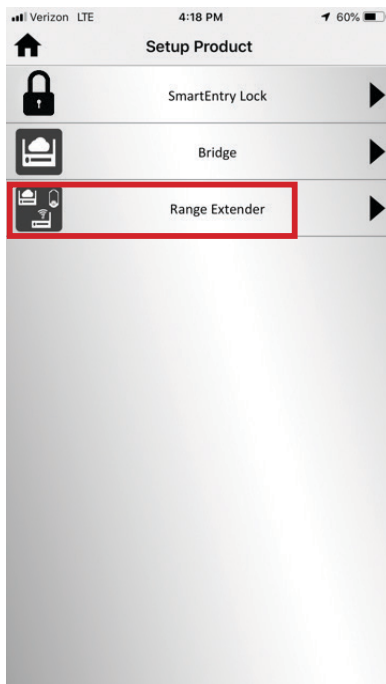

3/4

- Select **Range Extender** from the list.

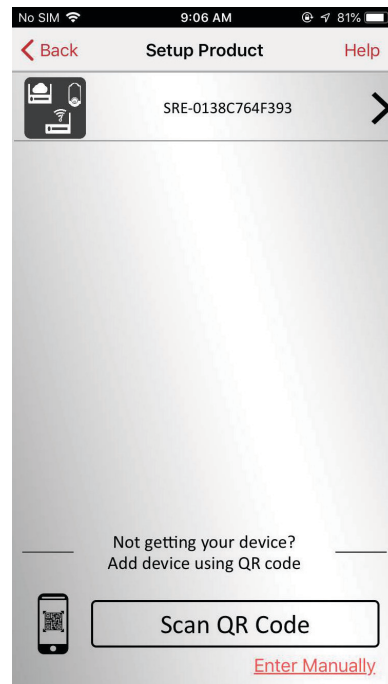

4/4

- Select your **Range Extender** from the list.
- If your device is not showing, add it by scanning its QR code or entering it manually.

**SMARTENTRY RANGE EXTENDER: REGISTER TO SERVER 2/2**

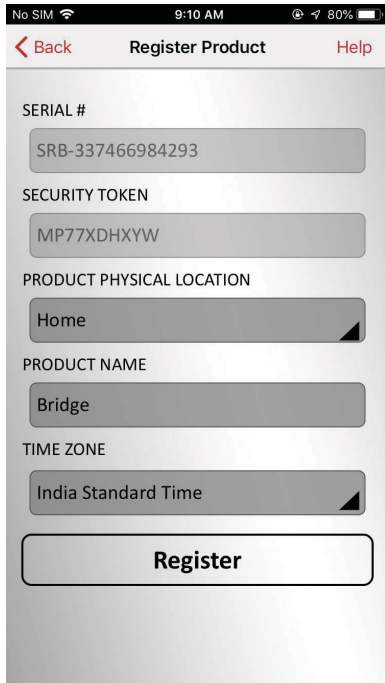

**1/4**  
• Provide **Name, Location, and Time Zone**

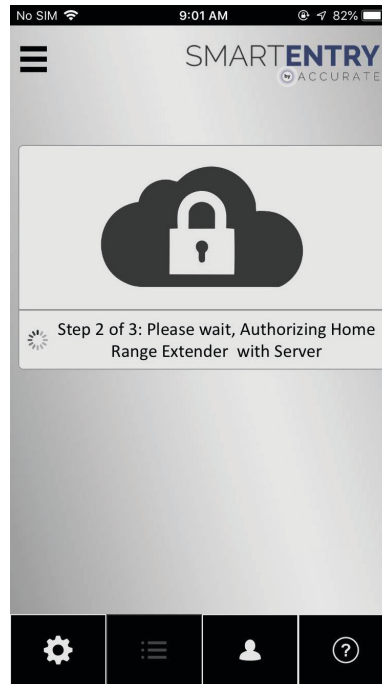

**2/4**  
• The Range Extender will start the set up process.

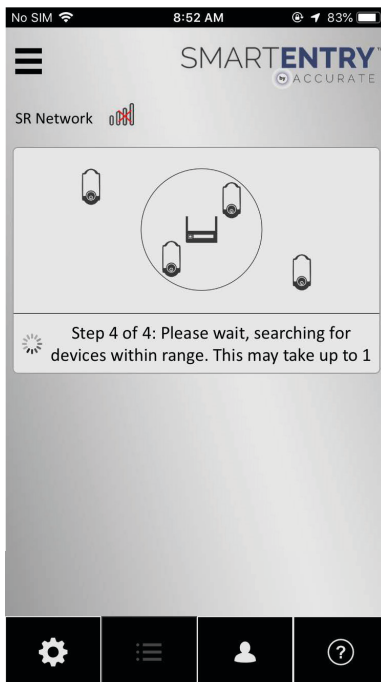

**3/4**  
• The Range Extender will search nearby device and connect

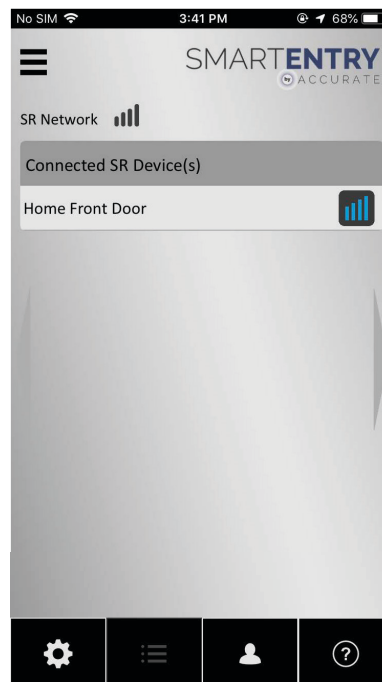

**4/4**  
• List of connected devices and their status.