

INSIDE OF DOOR

OUTSIDE OF DOOR

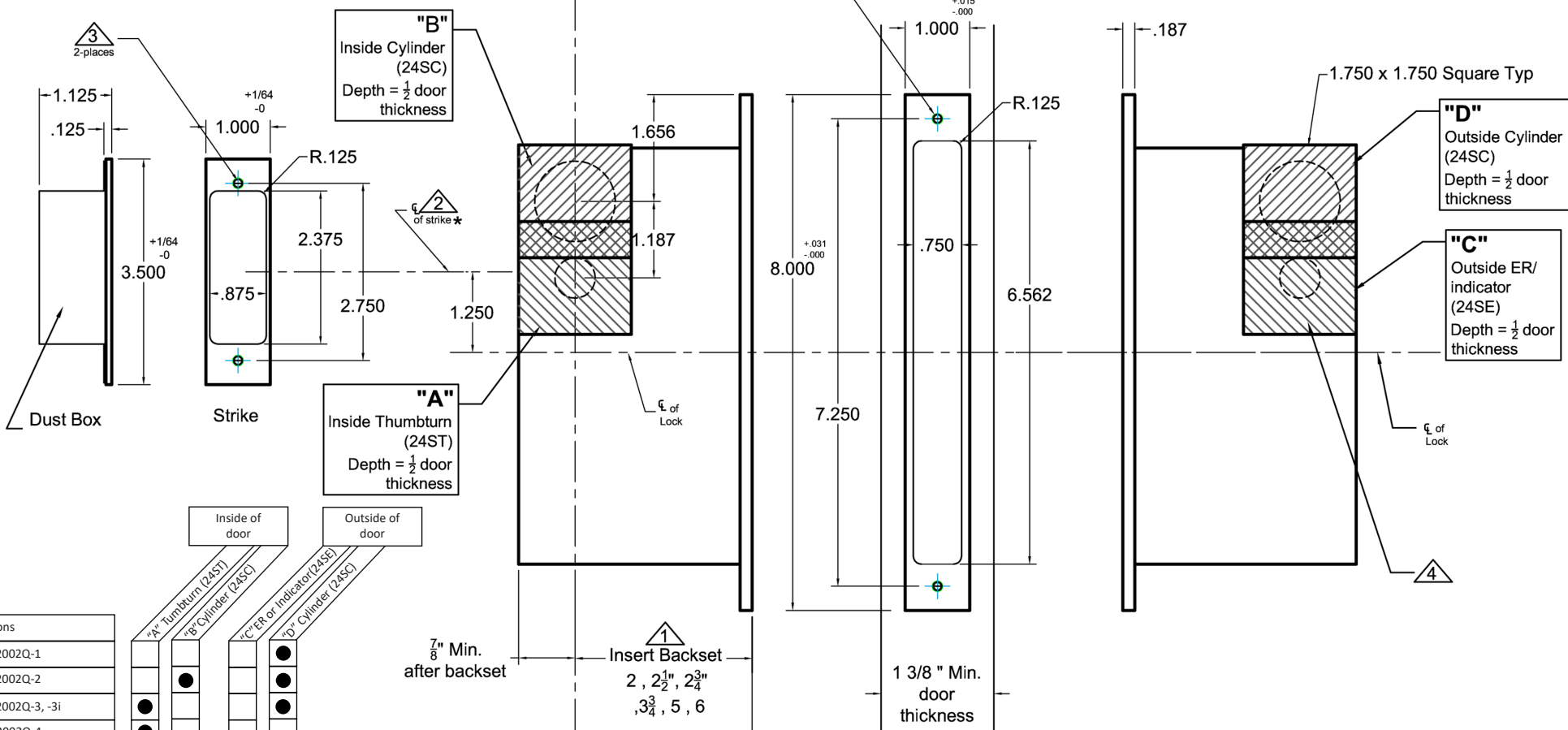

Lock Functions
2002CPDL/2002Q-1
2002CPDL/2002Q-2
2002CPDL/2002Q-3, -3i
2002CPDL/2002Q-4
2002CPDL/2002Q-5, -5i

● Requires Hole

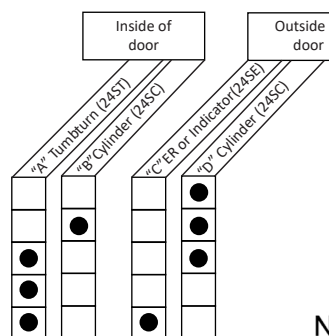

Notes:

- 1** Insert backset here 2", 2 1/2", 2 3/4", 3 3/4", 5", 6"
- 2** Strike is 1 1/4" above centerline of lock
- 3** Prep for #8 wood or 8-32 machine screws
- 4** After the lock is installed and works properly. Pre-drill screw holes for the flush pulls. Then mount the flush pulls with the provided screws.

Additional Notes:

- a) **Responsibility:** Door and frame manufacturers are responsible for providing adequate construction or re-inforcement for proper installation of hardware shown.
- b) See Spec.2002CPDL/2002Q and Spec.24ST/24SC/24SE for additional details.



Standard 2002CPDL/2002Q - 24ST, 24SC, 24SE Flush Pull - All Backsets

T-ALH.2002CPDL.2002Q.24S