



# ACCURATE LOCK & HARDWARE

AMERICAN CRAFTED SINCE 1972

---

## 2011PDP + 2011PDP-Q

POCKET DOOR EDGE PULL WITH LARGE BALE

## 2011PDP POCKET DOOR EDGE PULL WITH LARGE BALE

The 2011PDP is a Pocket Door Edge Pull featuring a large bale designed for passage, non-locking applications on space-saving doors. Also available as 2011PDP-Q Quiet Pocket Door Edge Pull featuring a quiet, slow-release edge pull. Pair with Blank Flush Pulls.



**2011PDP PASSAGE SET  
EXPOSED FASTENERS**

# Pocket Door Hardware Sets 2011PDP + 2011PDP-Q



**2011PDP**



**2011PDP-Q**

## 2011PDP + 2011PDP-Q POCKET DOOR EDGE PULL WITH LARGE BALE

- For passage, non-locking pocket doors (pair with Blank Flush Pulls)
- Available with Quiet Pocket Door Pull that features a Quiet slow release edge pull pops out of the lock with press of a button allowing for comfortable operation to pull door out of pocket.

# 2011PDP: Technical Details

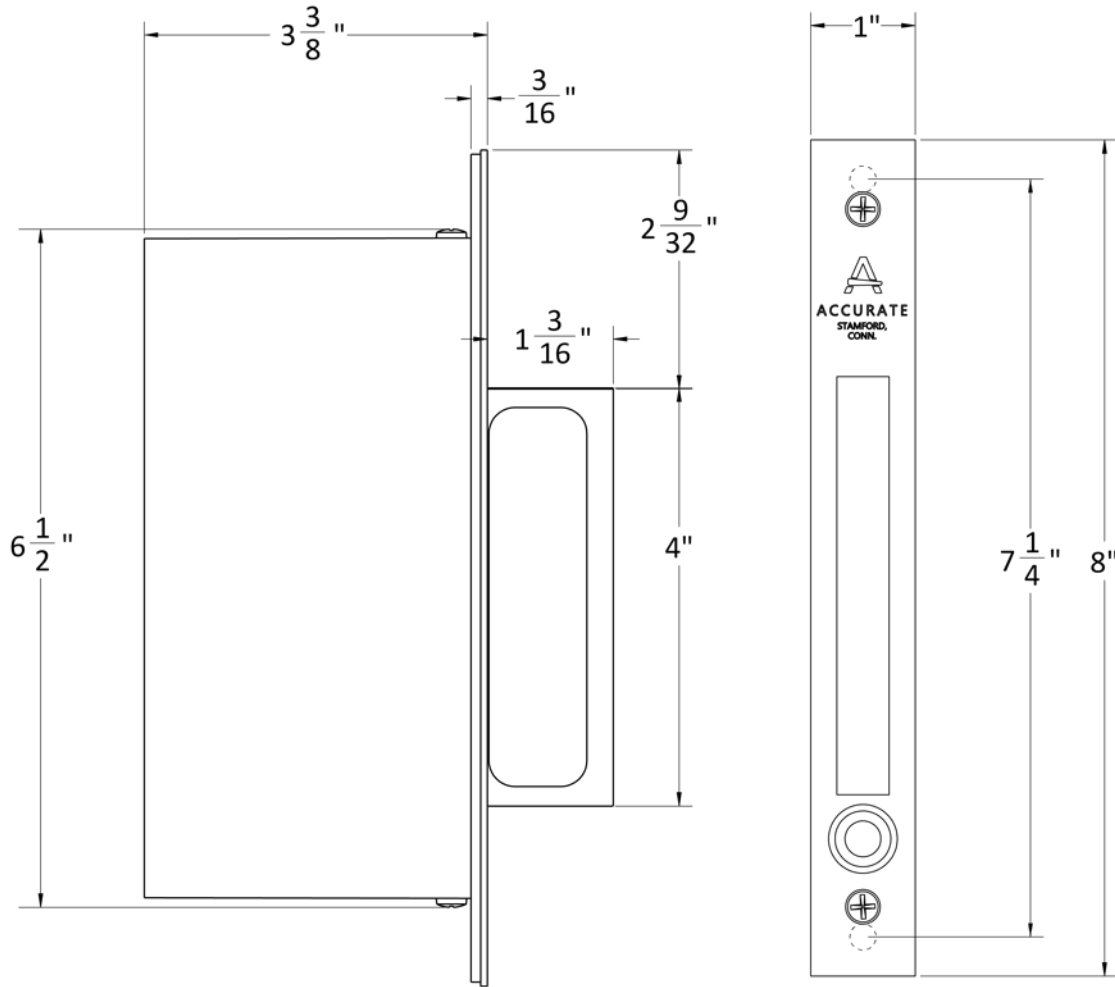

$3 \frac{3}{8}$ " overall depth standard

**CASE:** Heavy gauge, wrought ( $1 \frac{1}{16}$ " thick)

**ARMOR FRONT:**  $1$ " wide,  $8$ " standard made from brass, bronze or stainless steel and finished as required

**PULL:**  $\frac{1}{2}$ " thick,  $4$ " high,  $1 \frac{3}{16}$ " throw

# HOW TO SPECIFY

## LOCK. FINISH.OPTIONS

### LOCK

2011PDP  
2011PDP-Q

### OPTIONS

Finished bolts/buttons/bales/backplates  
where applicable for an upcharge

## EXAMPLES

Quiet Pocket Door Edge Pull with Large Bale

E.g.: 2011PDP-Q.**US26D**

Pocket Door Edge Pull with Large Bale

E.g.: 2011PDP.**US3**

Pocket Door Edge Pull with Large Bale | All Bolts Finished

E.g.: 2011PDP.**US19.US19BOLTS**

## FINISHES

**GROUP 1:** US4, US4NL, US32D\*, US26D

**GROUP 2:** US3, US3NL, US26, US32\*, US9\*, US10\*, US10B, US14, US15, US19

**GROUP 3:** BN, BB, TN, TB, DURO, ESN, US15A, US5

Applicable finishes come standard with [Cerakote Premium Protective Coating](#). Available in gloss or matte.

\* Trim options (including Accurate Levers) may not be available in US32D, US32, US9, or US10 finish. Please call for assistance.

To view example of finishes visit: [Accurate Finishes](#).

**ACCURATE LOCK & HARDWARE  
MANUFACTURERS OF LOCKS AND  
CUSTOM ARCHITECTURAL HARDWARE**

1 Annie Place | Stamford, CT 06902

**P:** 203.348.8865

**F:** 203.348.5234

**E:** sales@accuratelockandhardware.com

**www.accuratelockandhardware.com**



**AMERICAN CRAFTED  
— SINCE 1972 —**