



ACCURATE

LOCK & HARDWARE

AMERICAN CRAFTED SINCE 1972

M9100E Motor Drive Electrified Mortise Locks

FOR EFFICIENT + FLEXIBLE ACCESS CONTROL SYSTEM DESIGN

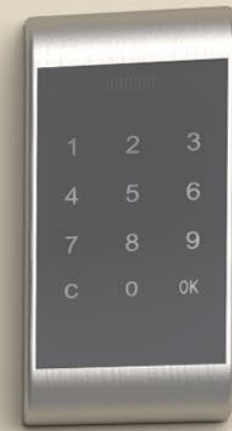

M9100E MOTOR DRIVE ELECTRIC MORTISE LOCKS

GET IT RIGHT ALL THE TIME

The modern upgrade to last generation's solenoid-driven locks has more flexibility, monitoring features, and options for efficient and flexible access control system design.

Additional functions offered allow for a seamless switch between electronic access and mechanical passage (M9145E via cylinder or M9156E via toggle action).

M9100E Product Benefits

IMPROVED FLEXIBILITY

- Universal output voltage (accepts between 11V – 30V, versus solenoid versions that are 12V, 24V, VAC, and VDC specific)
- Can easily be changed from FAIL SECURE to FAIL SAFE to adapt to design variations

MORE FUNCTIONALITY

- State-of-the-art monitor functions starting at a 2-1/2" backset include: **AE** (Authorized Egress/Request to Exit), **AM** (Auxiliary Latch Monitor), **LM** (Latch Bolt Monitor), **LB** (Locking Bar Monitor), **SM** (Combined AM + LB Monitoring) **DPS** (Door Position Monitoring), and **LPF** (Lock-out privacy)

LONGER LIFE

- Adaptable to new technology

SAVE POWER, SAVE MONEY

- A motor drive lock costs significantly less per year to operate at \$0.25, compared to a solenoid lock that costs \$8.33*

STAY COOL

- Low current draw produces minimal heat, eliminating "hot levers"

BE GREEN

- Low power requirement is ideal for environmentally friendly access control systems

IN GOOD COMPANY

- The same motor functionality is used by other trusted manufacturers including: Schlage, Sargent, Corbin Russwin, Hager, etc.

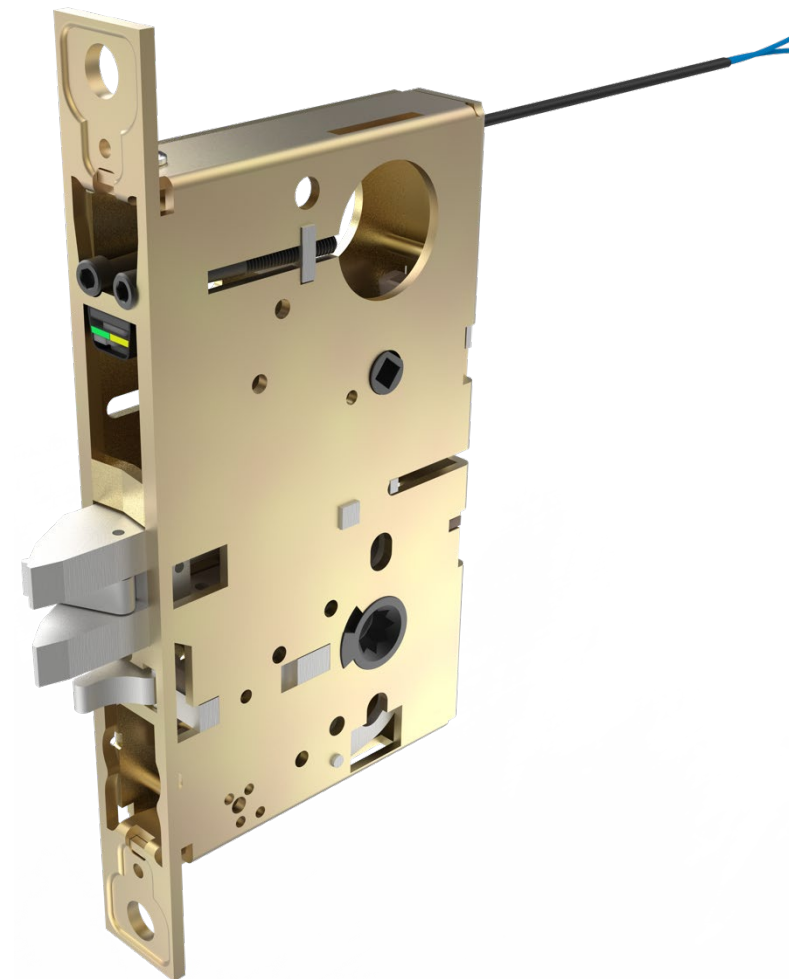



M9100E Dimensions

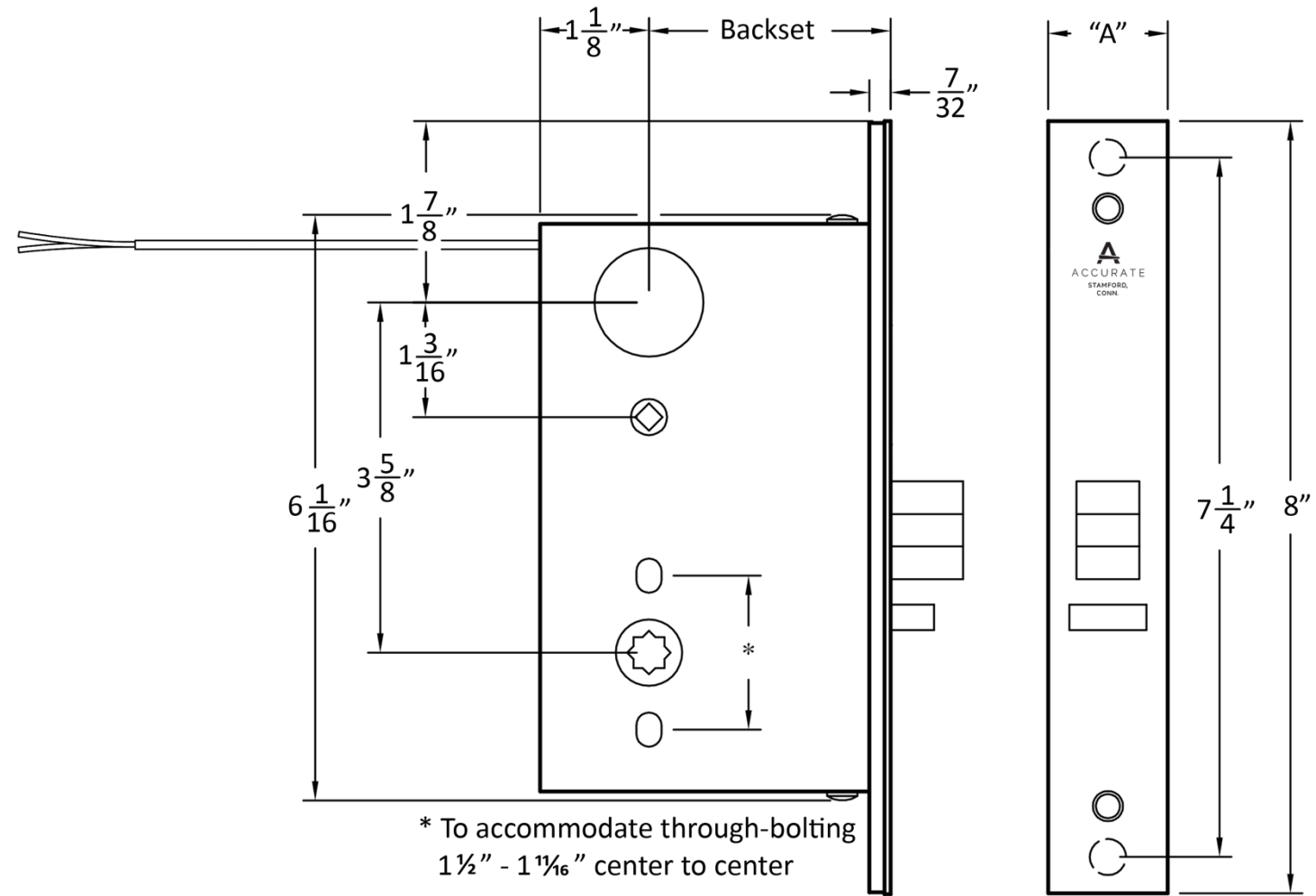

"A" M9100E SERIES - 1 1/4"
M9000E SERIES - 1"

M9100E Technical Details

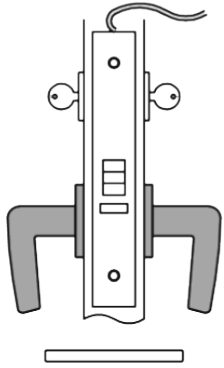

M9158E
INSTITUTION / ASYLUM

Latch bolt by key either side.
Auxiliary latch deadlocks
latch bolt.

FAIL SECURE OPERATION*: Inside and outside trim unlocked when power is applied and locked when power is removed.

FAIL SAFE OPERATION: Inside and outside trim locked when power is applied and unlocked when power is removed. Lockset will unlock in the event of power failure.

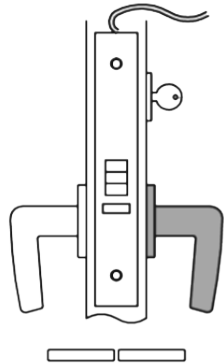

M9159E
STOREROOM

Inside trim always free.
Latch bolt by key outside.
Auxiliary latch deadlocks latch bolt.

FAIL SECURE OPERATION*: Outside trim unlocked when power is applied and locked when power is removed.

FAIL SAFE OPERATION: Outside trim locked when power is applied and unlocked when power is removed. Lockset will unlock in the event of power failure.

M9058E/M9059E for doors $1\frac{3}{8}$ minimum (1" armor front)
M9158E/M9159E for doors $1\frac{3}{4}$ minimum (1 $\frac{1}{4}$ " armor front)

UL Listed 3 Hour (Mechanics R13846/R27504 and Electronics R10121)

Grade 1 Certified to ANSI/BHMA A156.13.2005 Standard

BACKSETS: $2\frac{1}{2}$ " , $2\frac{3}{4}$ " , $3\frac{3}{4}$ " , 5" or 6"

OPERATION: Key Cylinder (by others) allows for mechanical entry via manual latch bolt retraction.

12-24V AC/DC (11V-30V Operating Range)
250mA MAX Inrush
10mA MAX Holding
Non-polarized Leads

**Lock is furnished as FAIL SECURE and can easily be changed to FAIL SAFE via the switch on the front.*

Optional Allegion and Assa Abloy Molex connectors available.

Longer lead wires available by the foot.

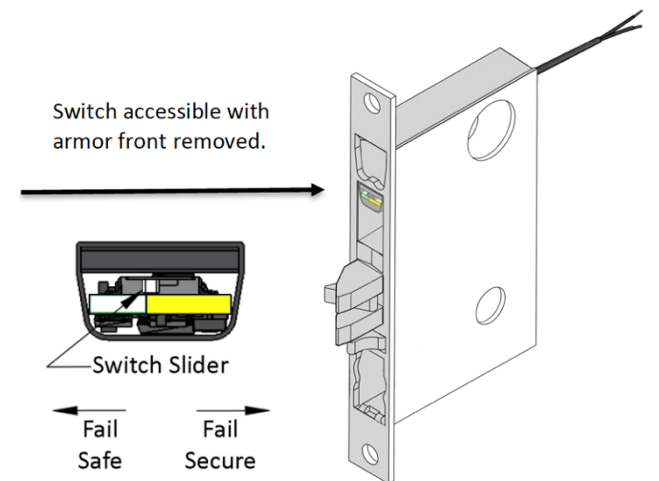

M9100E Technical Details

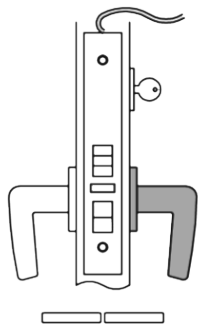

M9156E ENTRANCE

Inside trim always free.
Latch bolt by key outside.

Key Cylinder (by others) allows for mechanical entry via manual latch bolt retraction.

Auxiliary latch deadlocks latch bolt.

For passage mode, toggle can be set to keep outside lever unlocked. After unlocking lever with toggle, lever can only be re-locked by toggle, not by electronics.

FAIL SECURE OPERATION*: Outside trim unlocked when power is applied and locked when power is removed.

FAIL SAFE OPERATION: Outside trim locked when power is applied and unlocked when power is removed. Lockset will unlock in the event of power failure.

M9056E for doors $1\frac{3}{8}$ minimum (1" armor front)
M9156E for doors $1\frac{3}{4}$ minimum (1 $\frac{1}{4}$ " armor front)

UL Listed 3 Hour (Mechanics R13846/R27504 and Electronics R10121)

Grade 1 Certified to ANSI/BHMA A156.13.2005 Standard

BACKSETS: $2\frac{1}{2}$ ", $2\frac{3}{4}$ ", $3\frac{3}{4}$ ", 5" or 6"

12-24V AC/DC (11V-30V Operating Range)
250mA MAX Inrush
10mA MAX Holding
Non-polarized Leads

**Lock is furnished as FAIL SECURE and can easily be changed to FAIL SAFE via the switch on the front.*

Optional Allegion and Assa Abloy Molex connectors available.

Longer lead wires available by the foot.

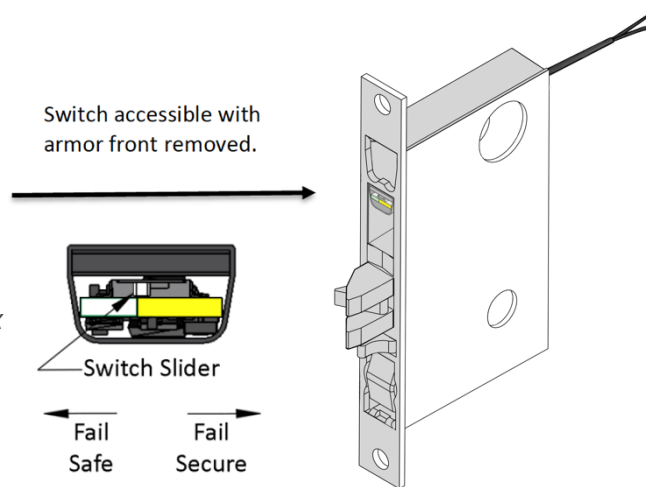

M9100E Technical Details

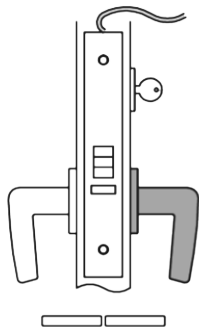

M9145E CLASSROOM LOCK

Inside trim always free.

Latch bolt by key outside.

Key Cylinder (by others) allows for mechanical entry via manual latch bolt retraction.

Auxiliary latch deadlocks latch bolt.

Rotating the key in one direction would place the lock in “unlocked” state (passage), blocking the electrified function.

Rotating the key in the opposite direction would return the lock to standard electrified operation.

FAIL SECURE OPERATION*: Outside trim unlocked when power is applied and locked when power is removed.

FAIL SAFE OPERATION: Outside trim locked when power is applied and unlocked when power is removed. Lockset will unlock in the event of power failure.

M9045E for doors $1\frac{3}{8}$ minimum (1” armor front)

M9145E for doors $1\frac{3}{4}$ minimum (1 $\frac{1}{4}$ ” armor front)

UL Listed 3 Hour (Mechanics R13846/R27504 and Electronics R10121)

Grade 1 Certified to ANSI/BHMA A156.13.2005 Standard

BACKSETS: $2\frac{1}{2}$ ”, $2\frac{3}{4}$ ”, $3\frac{3}{4}$ ”, 5” or 6”

12-24V AC/DC (11V-30V Operating Range)

250mA MAX Inrush

10mA MAX Holding

Non-polarized Leads

**Lock is furnished as FAIL SECURE and can easily be changed to FAIL SAFE via the switch on the front.*

Optional Allegion and Assa Abloy Molex connectors available.

Longer lead wires available by the foot.

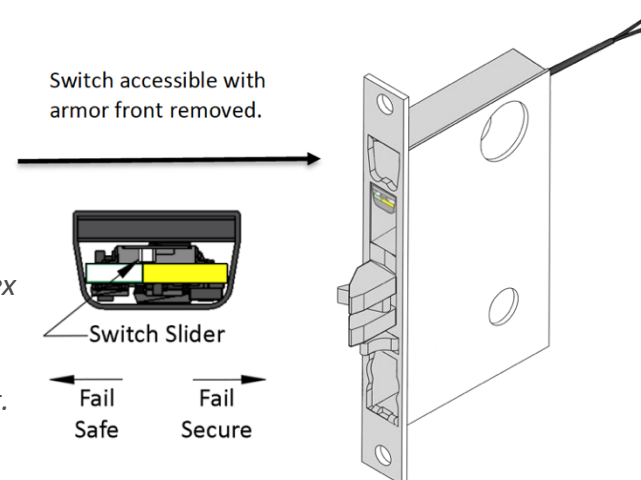

M9100E Monitoring Functions

AE - AUTHORIZED EGRESS

Also referred to as REQUEST TO EXIT (or REX switch), monitors the use of the INSIDE trim when the OUTSIDE trim is locked.

ELECTRICAL SPECIFICATIONS:

SPDT Mechanical switch

Voltage	Current
125 VAC	1 AMP
30 VDC	0.5 AMP

LM – LATCH BOLT MONITORING

Monitors the full extension of the main latch.

ELECTRICAL SPECIFICATIONS:

SPDT Mechanical switch

Voltage	Current
125 VAC	1 AMP
30 VDC	0.5 AMP

AM – DEAD LATCH MONITORING

Monitors the position of the dead latch. To activate switch, the lockset must be in the closed position with the auxiliary latch depressed and main latch extended.

ELECTRICAL SPECIFICATIONS:

SPDT Mechanical switch

Voltage	Current
125 VAC	1 AMP
30 VDC	0.5 AMP

LB – LOCKING BAR MONITORING

Monitors the position of the locking bar.

ELECTRICAL SPECIFICATIONS:

SPDT Mechanical switch

Voltage	Current
125 VAC	1 AMP
30 VDC	0.5 AMP

M9100E Monitoring Functions

SM – SECURITY MONITORING

A combination of AM and LB, SM monitors IN SERIES* the status of the locking bar (locked or unlocked position) and the status of the auxiliary latch (dead latch position).

Lockset must be locked with the main latch extended and the auxiliary latch depressed to get a secure signal. If any of the conditions are not met, lockset goes into an unsecure mode.

ELECTRICAL SPECIFICATIONS:

2 each SPDT Mechanical switches wired in series

Voltage	Current
---------	---------

125 VAC	1 AMP
---------	-------

30 VDC	0.5 AMP
--------	---------

** If independent monitoring is required (not in series), please specify as SM2 (this is a combination of AM and LB)*

DPS – DOOR POSITION SENSOR

Monitors the door position. A magnetic sensor mounted in the mortise lock reacts to the proximity of a magnet mounted behind the ASA strike.

ELECTRICAL SPECIFICATIONS:

SPDT Magnetic Reed switch

Voltage	Current
---------	---------

28 VDC	0.3 A
--------	-------

SM2 – SECURITY MONITORING

Independent monitoring of the deadlatch (AM) and the locking bar (LB) positions.

M9100E Monitoring Functions

FOR M9059E/M9159E ONLY

LPF – LOCK OUT PRIVACY MONITORING

For **FAIL SECURE** locks only: Engaging safe side turn piece disables remote access control unlocking (keypad or card reader) or scheduled unlock.

LPF OPTIONS:

- 1. LPF-Manual:** When LPF is engaged via thumb turn, it remains in this position until manually undone. Turning the inside lever does not reset the hub. After egress and closing the door, the card reader will not allow access and a key must be used.
 - Allows the user to first engage LPF while the door is closed, then egress without having a to then use a key to re-engage.
- 2. LPF-Reset Mode:** Turning the inside lever resets the LPF to off position. Similar to simultaneous deadbolt and latch retraction, the LPF hub goes back to home position (off) when inside lever is rotated.
 - This mode is better for bedrooms or residences where the user will not get locked out

APPLICATIONS:

Enhanced security in office buildings after hours, SCIF/rooms housing sensitive information and opening subject to authorized access on a temporary basis.

Enhanced privacy in commercial buildings (for shared staff showers, restrooms, office, etc.) or for private residences with multiple service provider access (e.g. lock-out during vacation or need to immediately lock out specific user until system updates).

M9100E Monitoring Function Matrix

M9158E/M9159E Allowable Monitoring Combinations

APPLICABLE FUNCTIONS	M9058E/M9059E & M9158E/M9159E
LOCK CONFIGURATIONS	Standard, Upside Down (USD), B (Baldwin) Configurations
BACKSETS	2-1/2", 2-3/4", 3-3/4", 5", 6"
TRIM CONFIGURATIONS	LxL, KxK, KxL, TPxK, TPxL, TPxTP

FOR MONITOR COMBINATIONS, READ CHART LEFT TO RIGHT

AE Authorized Egress	AM Auxillary Latch Monitor	LB Locking Bar Monitor	SM Security Monitoring <i>AM+LB in Series (3 wires)</i>	SM2 Security Monitoring <i>AM+LB (6 wires)</i>	LM Latch Bolt Monitor	DPS Door Position Sensor
●	●	●			●	●
●			●		●	●
●				●	●	●
●					●	●

M9100E Monitoring Function Matrix

M9158E/M9159E Allowable Monitoring Combinations

APPLICABLE FUNCTIONS	M9058E/M9059E & M9158E/M9159E Functions (Lockout Privacy Function Built-in) (Fail Secure Locks Only)					
LOCK CONFIGURATIONS	Standard, Upside Down (USD), B (Baldwin) Configurations					
BACKSETS	2-1/2", 2-3/4", 3-3/4", 5", 6"					
TRIM CONFIGURATIONS	LxL, KxK, KxL, TPxK, TPxL, TPxTP					
FOR MONITOR COMBINATIONS, READ CHART LEFT TO RIGHT						
AE Authorized Egress	AM Auxillary Latch Monitor	LB Locking Bar Monitor	SM Security Monitoring <i>AM+LB in Series (3 wires)</i>	SM2 Security Monitoring <i>AM+LB (6 wires)</i>	LM Latch Bolt Monitor	DPS Door Position Sensor
●					●	●

Not TP x TP

M9100E Monitoring Function Matrix

M9145E Allowable Monitoring Combinations

APPLICABLE FUNCTIONS	M9045E/M9145E Functions (Key Activated Passage Function Built-in)		
LOCK CONFIGURATIONS	Standard, Upside Down (USD), B (Baldwin) Configurations		
BACKSETS	2-1/2", 2-3/4", 3-3/4", 5", 6"		
TRIM CONFIGURATIONS	LxL, KxK, KxL, TPxK, TPxL, TPxTP		
FOR MONITOR COMBINATIONS, READ CHART LEFT TO RIGHT			
AE Authorized Egress	LM Latch Bolt Monitor	DPS Door Position Sensor	
●	●	●	

M9100E Monitoring Function Matrix

M9156E Allowable Monitoring Combinations

APPLICABLE FUNCTIONS	M9056E/M9156E Functions (Toggle for Passage Function Built-in)
LOCK CONFIGURATIONS	Standard, Upside Down (USD), B (Baldwin) Configurations
BACKSETS	2-1/2", 2-3/4", 3-3/4", 5", 6"
TRIM CONFIGURATIONS	LxL, KxK, KxL, TPxK, TPxL, TPxTP

FOR MONITOR COMBINATIONS, READ CHART LEFT TO RIGHT

AE Authorized Egress	AM Auxillary Latch Monitor	LB Locking Bar Monitor	SM Security Monitoring <i>AM+LB in Series (3 wires)</i>	SM2 Security Monitoring <i>AM+LB (6 wires)</i>	LM Latch Bolt Monitor	DPS Door Position Sensor
●	●	●			●	●
●			●		●	●
●				●	●	●

Accurate Lever Trim

15L LEVER

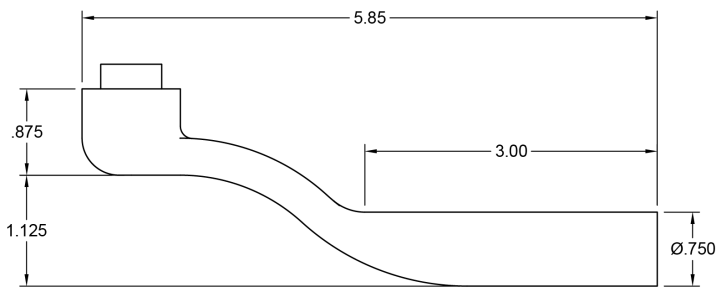

16L LEVER

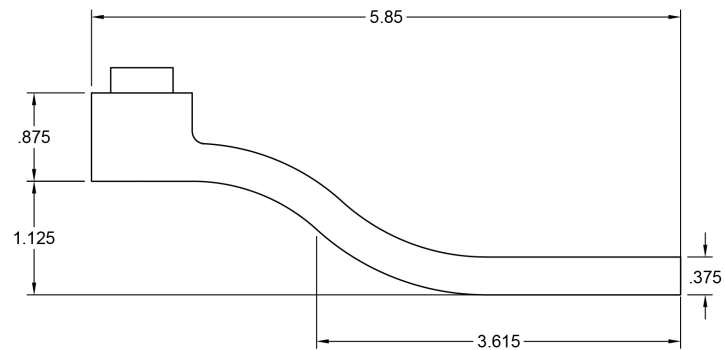

17L LEVER

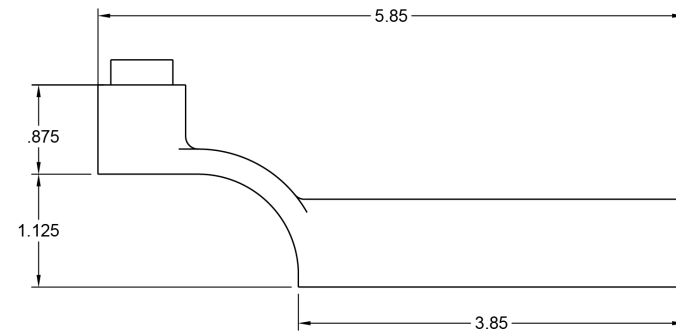

Accurate Lever Trim

18L LEVER

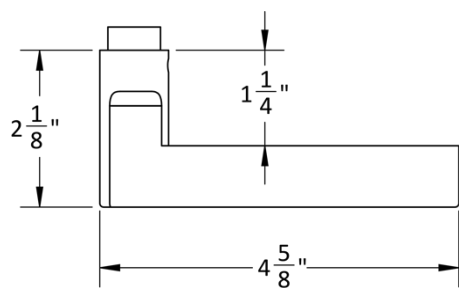

19L LEVER

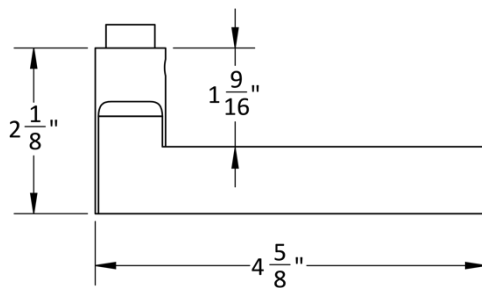

20L LEVER

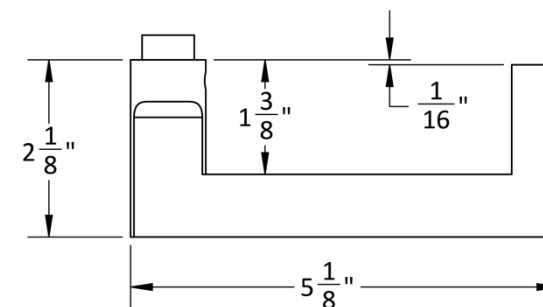
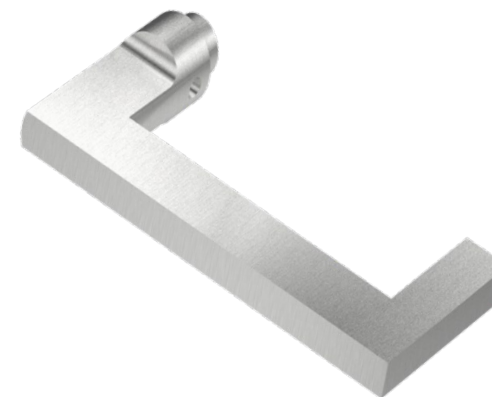

Accurate Lever Trim

21L LEVER

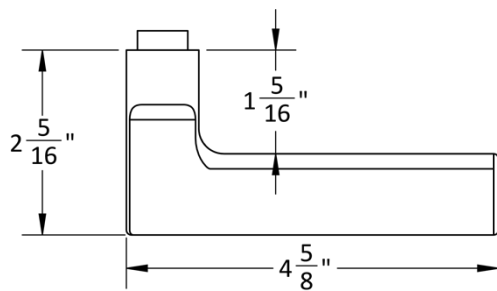

24L LEVER

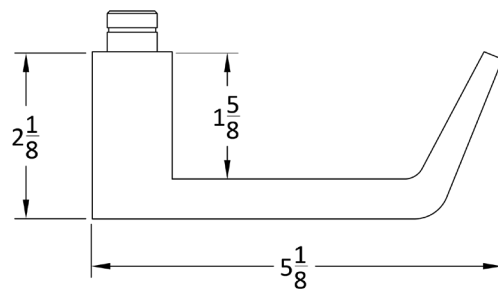
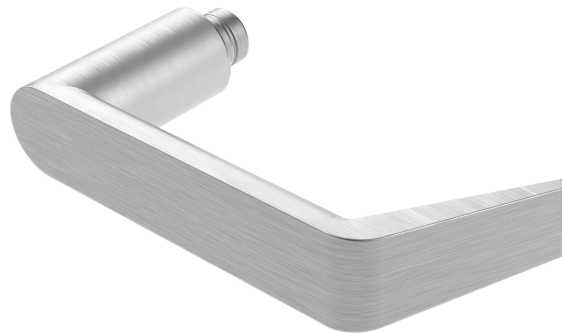

29L LEVER

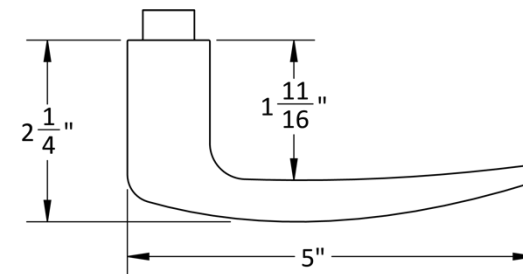

Accurate Lever Trim

39L LEVER

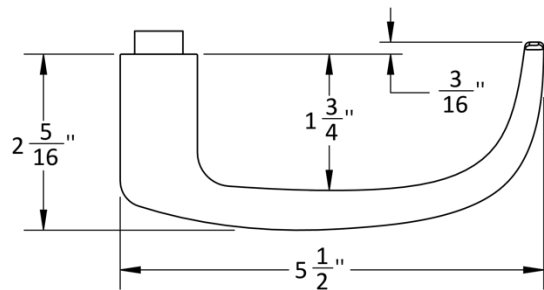

72L LEVER

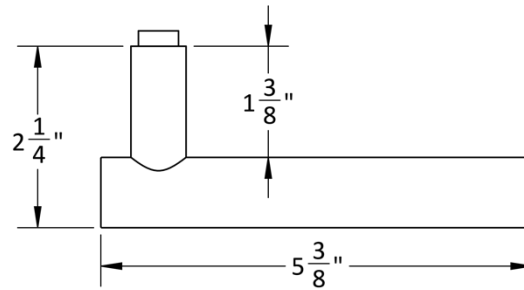

84L LEVER

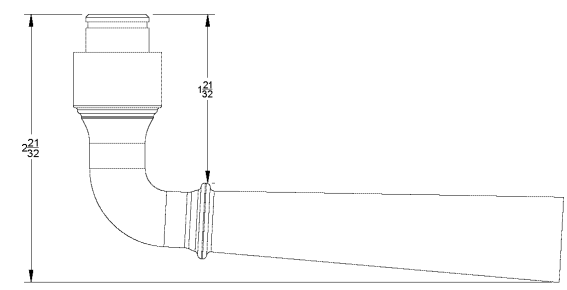

Accurate Rose Options

1R ROSE

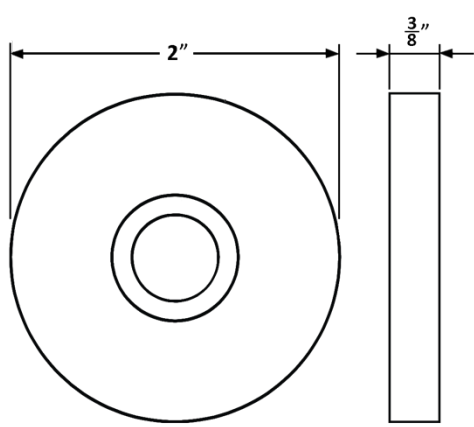
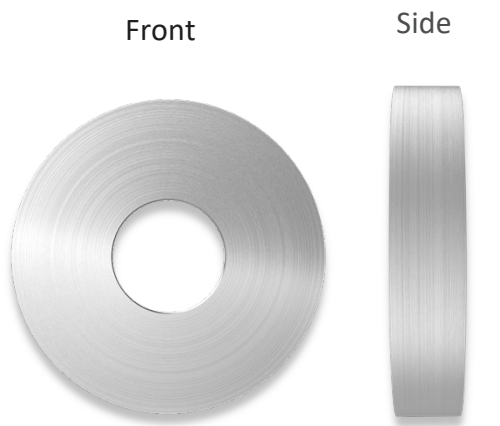

SILENTPAC™ LEVER DAMPENING DISC CAN BE SPECIFIED WITH THE 1R ROSE VISIT SILENTPACSOLUTIONS.COM

2R ROSE

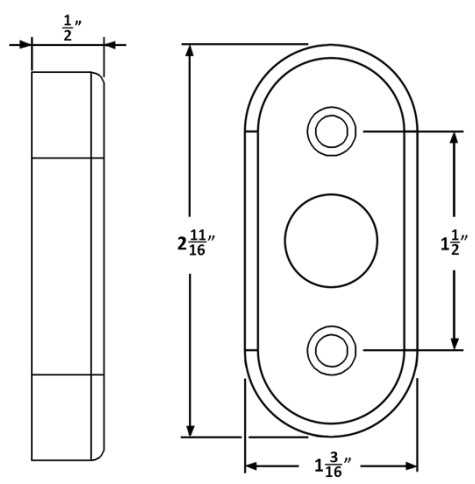
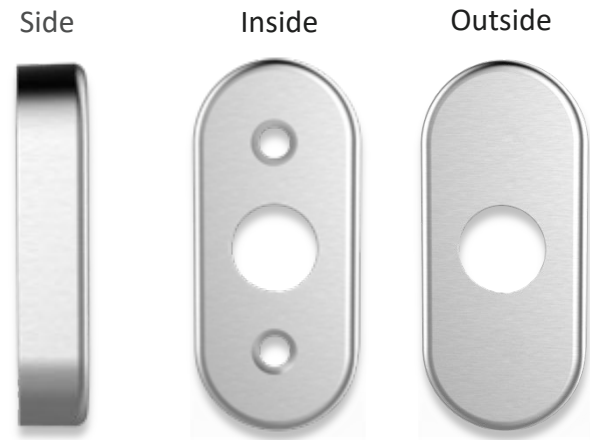

4R ROSE

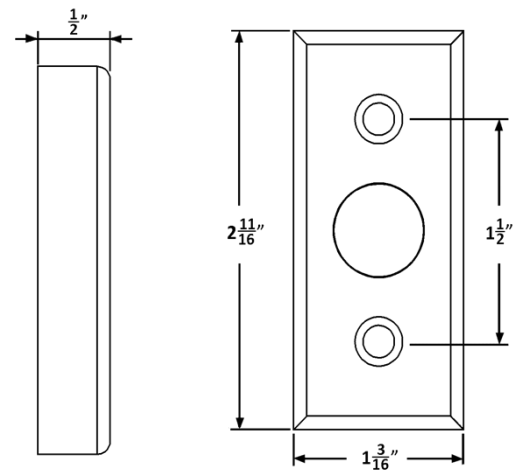
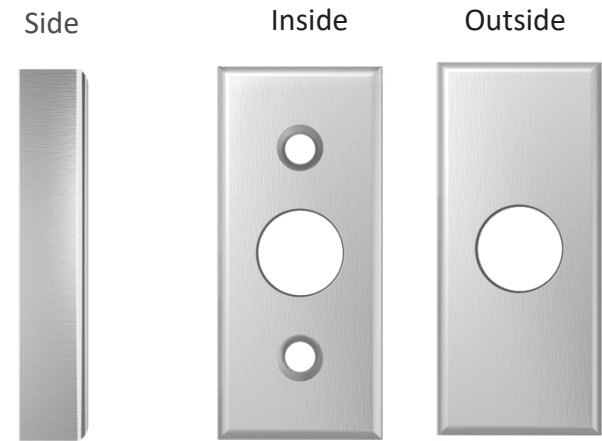

Accurate Escutcheon Options

POSSIBLE ESCUTCHEON COMBINATIONS*:

1E-B x 1E-C Blank x Cylinder Cutout

1E-C x 1E-C Cylinder Cutout x Cylinder Cutout



1E-B
Blank

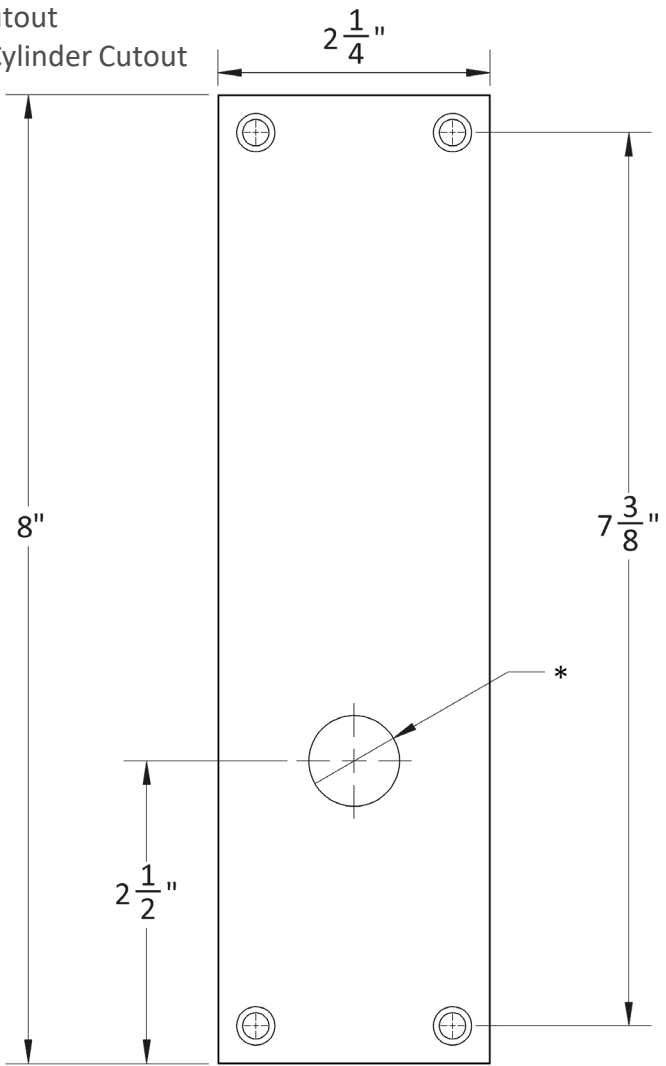

* Dimensions may vary depending on trim



1E-C
Cylinder Cutout

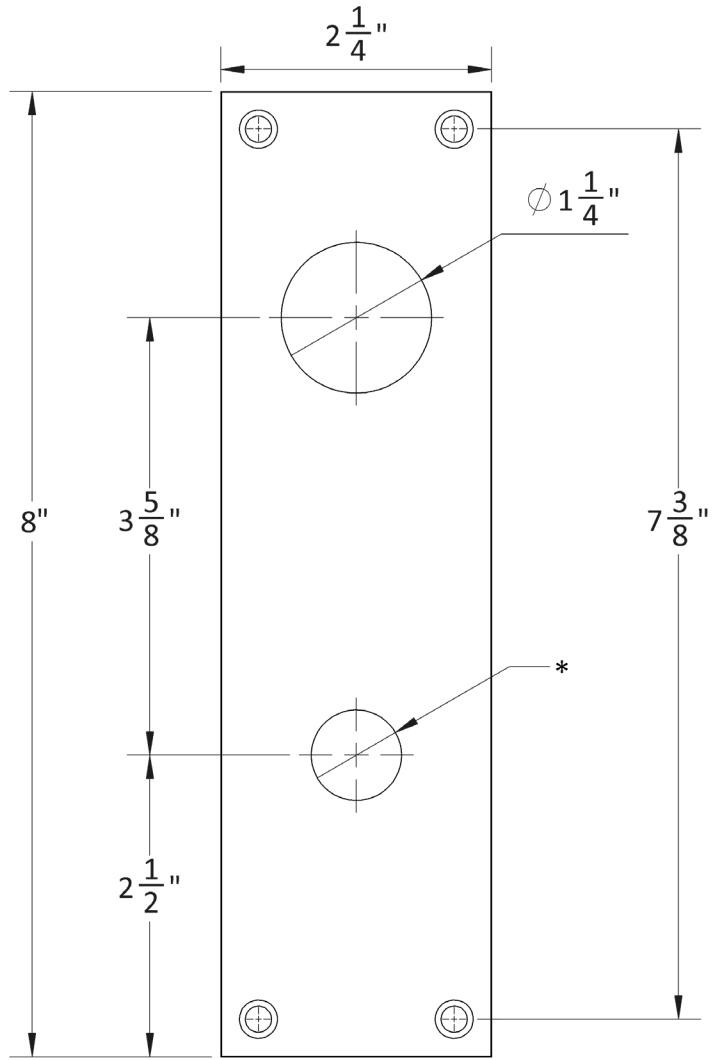

* Dimensions may vary depending on trim

*Additional trim options available for LPF Monitoring (see pg. 17-18)

Trim Options for LPF Lock Out Privacy Function

GF1106



7200Sci



7200ADA

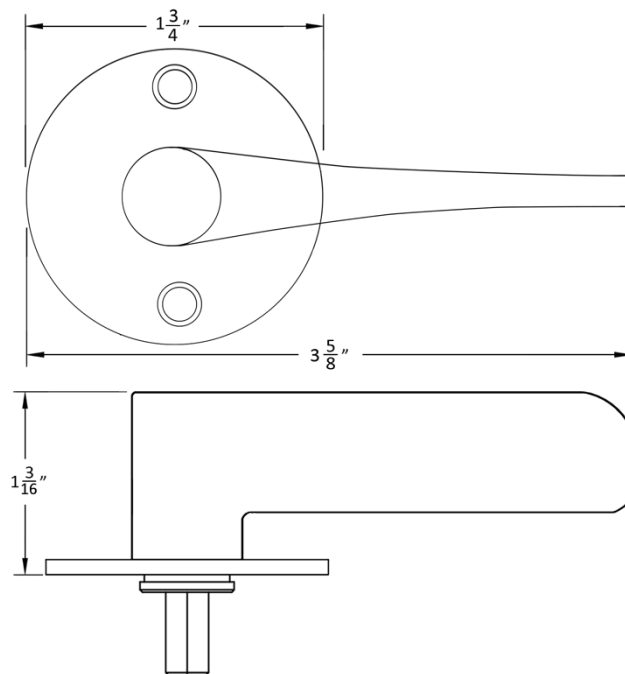
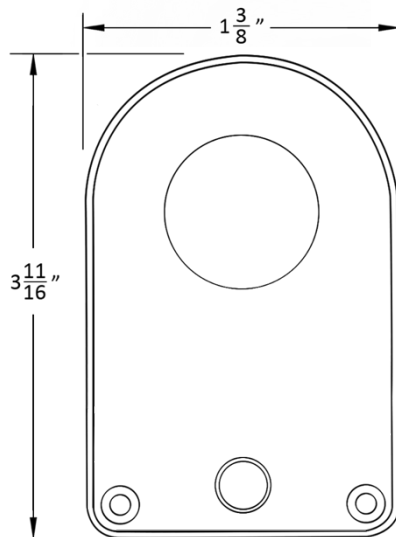
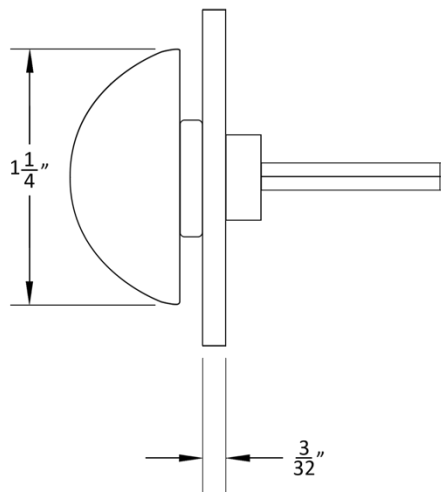
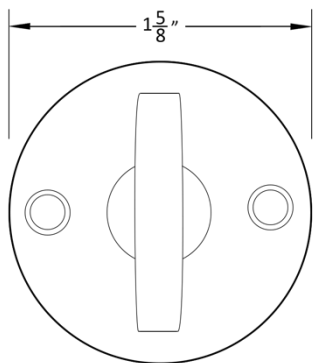

Trim Options for LPF Lock Out Privacy Function

POSSIBLE ESCUTCHEON COMBINATIONS*:

1E-C x 1E-T Cylinder Cutout x Thumb Turn

1E-Ci x 1E-T Cylinder Cutout with Indicator x Thumb Turn

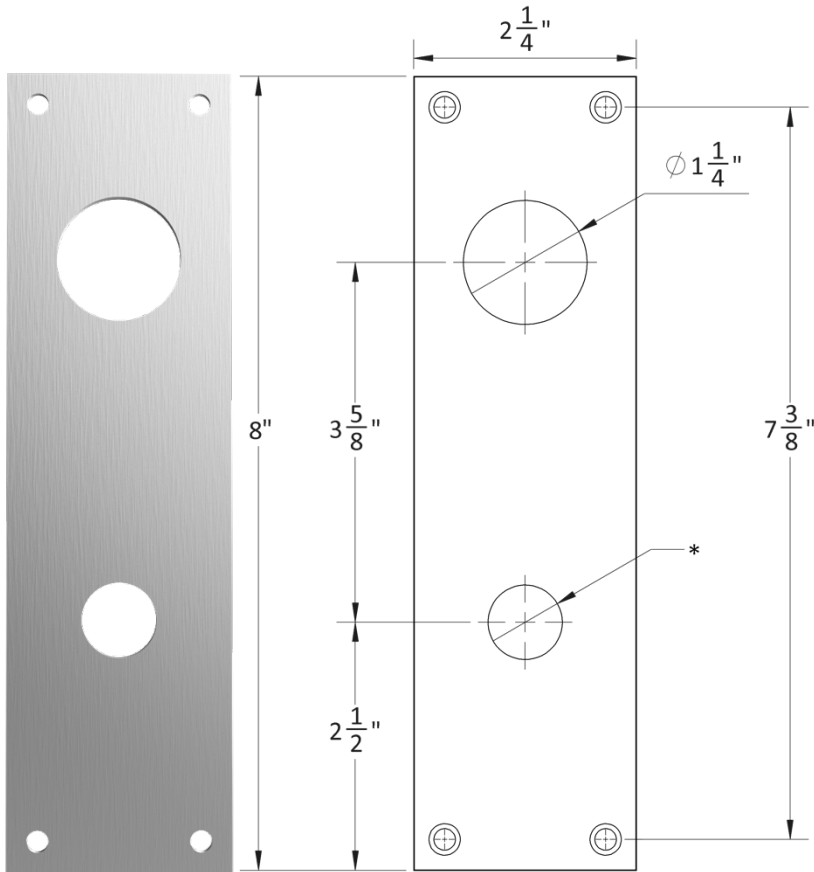

1E-B

Cylinder
Cutout

* Dimensions may vary depending on trim

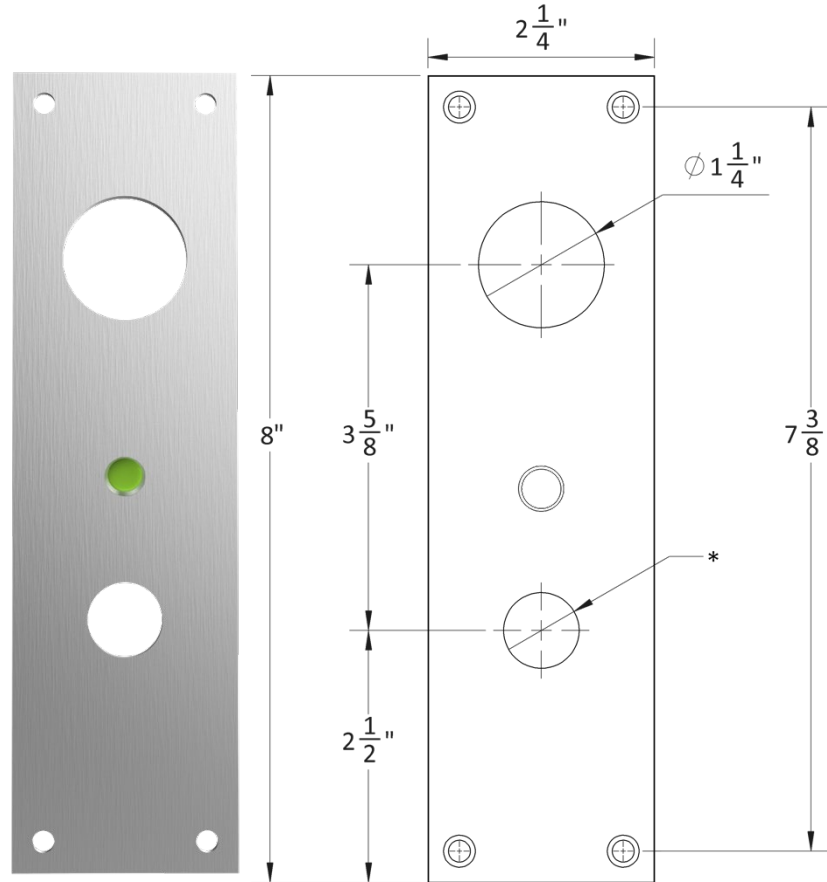

1E-Ci

Cylinder Cutout
with Indicator

* Dimensions may vary depending on trim

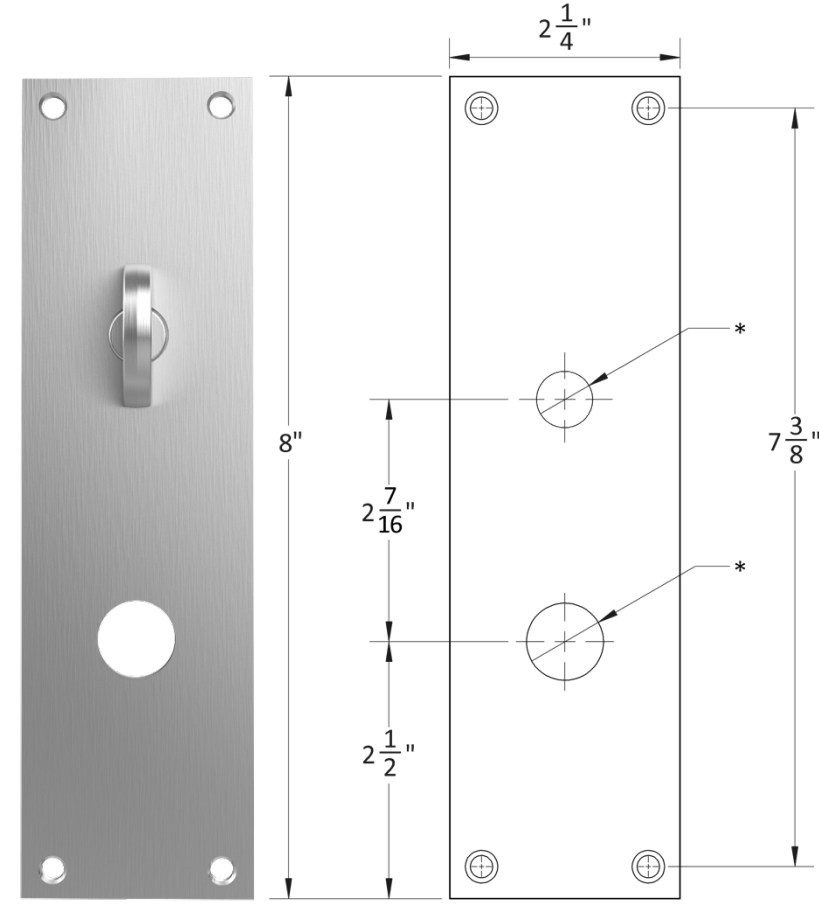

1E-T

With GF1106 Thumb Turn
(for ADA thumb turn,
please specify 1E-T-ADA)

* Dimensions may vary depending on trim

5000TG Thumb Grip Entry Set Trim

INTERIOR TRIM

Shown with 19L Lever

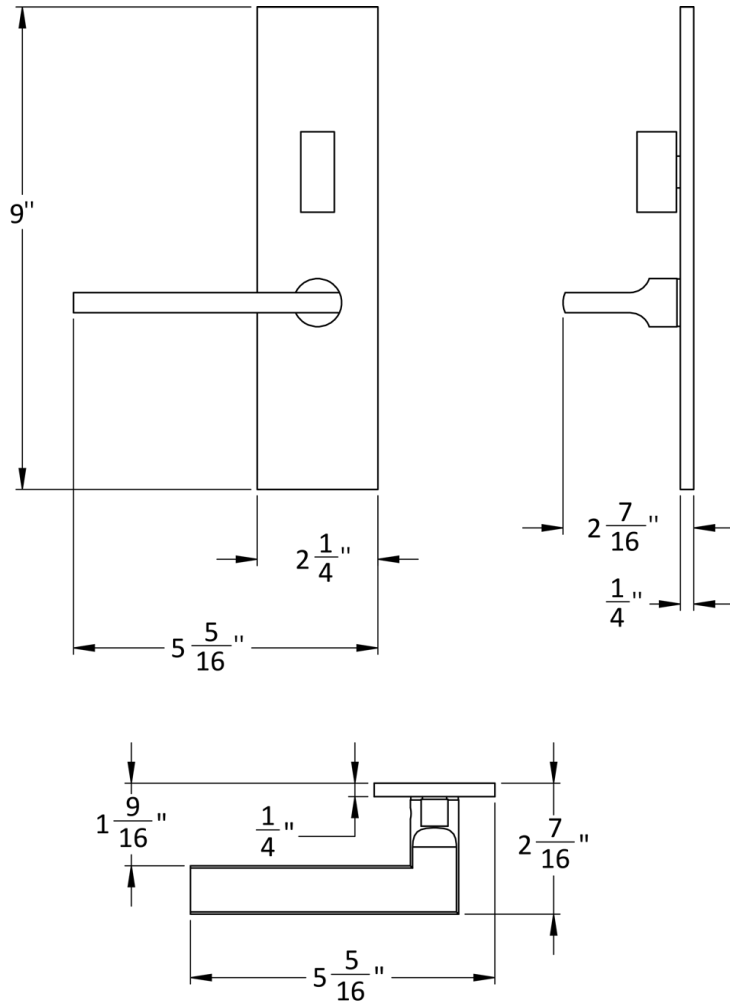

EXTERIOR TRIM

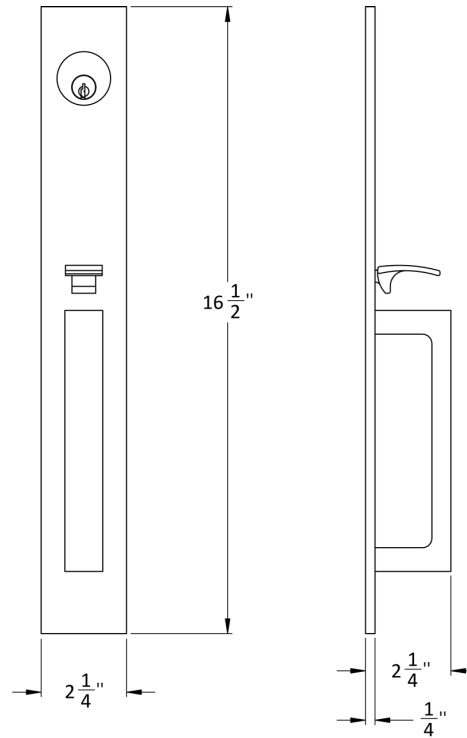

SCAN TO LEARN MORE

HOW TO SPECIFY

HANDING

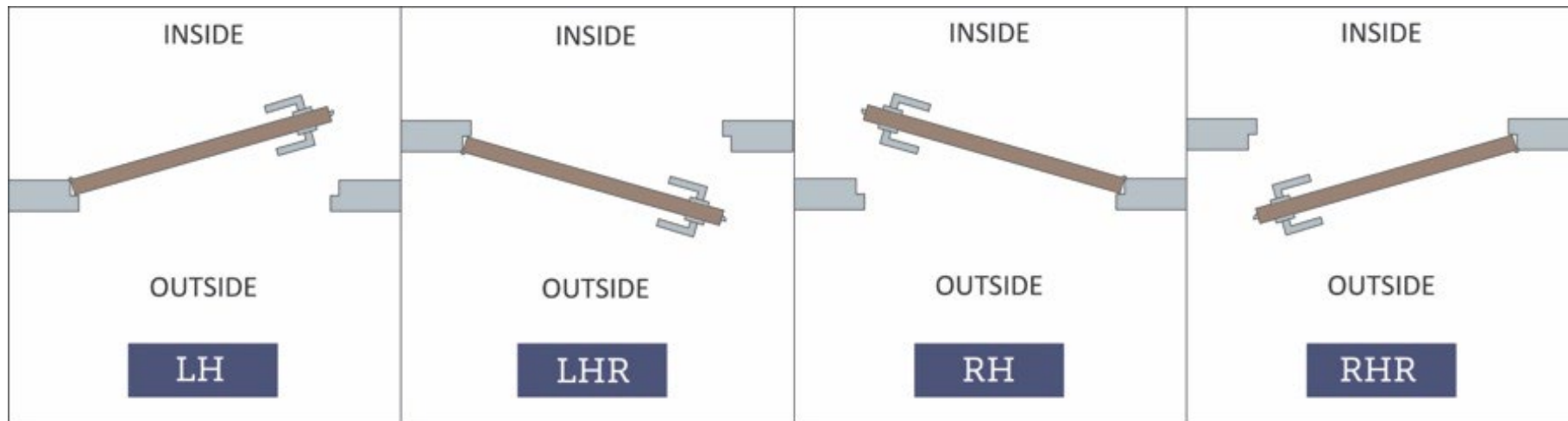

FINISHES

GROUP 1: US4, US4NL, US32D*, US26D

GROUP 2: US3, US3NL, US26, US32*, US9*, US10*, US10B, US14, US15, US19

GROUP 3: BN, BB, TN, TB, DURO, ESN, US15A, US5

* Trim options (including Accurate Levers) may not be available in US32D, US32, US9, or US10 finish. Please call for assistance.

To view example of finishes visit: [Accurate Finishes](#).

CYLINDERS & KEYING

M9100E Series locks accept any standard American mortise cylinder. For details on required cams and compatibility with other manufacturers' cylinders, please visit: [Accurate Support](#).

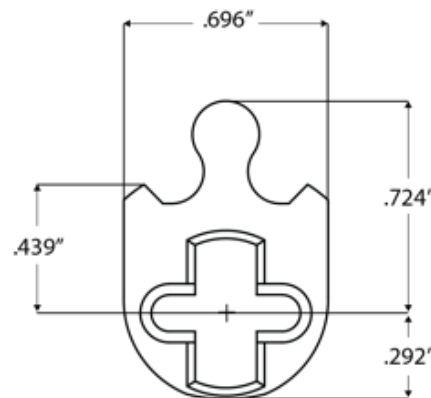

HOW TO SPECIFY

FUNCTION-MONITOR.BACKSET.TRIM.FINISH.HAND.DOORTHICKNESS

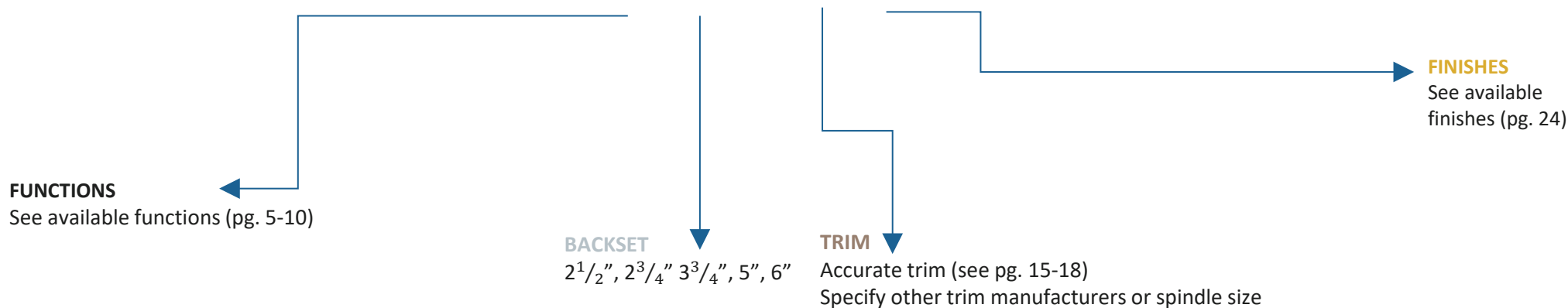

EXAMPLES

Electrified Lock for use with Double Cylinder | Authorized Egress | Accurate Trim

E.g.: M9158E-AE.212.29L/2R.US26D.RH.134

Electrified Lock | Dead Latch Monitoring | Accurate Trim

E.g.: M9159E-AM.234.19L/1R.US4.LH.134

Electrified Lock | Passage Mode by Authorized Personnel Only | Accurate Trim

E.g.: M9145E.234.20L/1E.US26D.RH.134

Electrified Lock with Party Function (leave in passage mode for periods of time) and Request to Exit | Other Manufacturers' Trim*

E.g.: M9156E-AE.212.7mm.US3NL.RH.134

*Note: For compatibility with other manufacturers' trim please call for assistance.

SPECIAL OPTIONS AVAILABLE

- SS-Security Strikes
- USD K x K Upside Down (cylinder/thumb turn below knobs)
- USD L x L Upside Down (cylinder/thumb turn below levers)
- SLB Solid Latch Bolt (not available for SilentPac™ Quiet Lock)
- K x L Knob Outside, Lever Inside
- L x K Lever Outside, Knob Inside
- TP x L Thumbpress Outside, Lever Inside
- TP x K Thumbpress Outside, Knob Inside
- TP x TP Thumbpress Outside, Thumbpress Inside
- Compatible with the following add-ons: SilentPac™ Quiet Lock, SilentPac™ Lever Dampening Disc, High Security Solutions

**ACCURATE LOCK & HARDWARE
MANUFACTURERS OF LOCKS AND
CUSTOM ARCHITECTURAL HARDWARE**

1 Annie Place | Stamford, CT 06902

P: 203.348.8865

F: 203.348.5234

E: sales@accuratelockandhardware.com

www.accuratelockandhardware.com



**AMERICAN CRAFTED
— SINCE 1972 —**