

X30 125cc RL-C TAG

		FEATURES - CARACTERISTIQUES	
		Cylinder volume <i>Volume du cylindre</i>	123.67 cm ³
		Bore <i>Alésage</i>	54 mm
		Max. bore <i>Alésage max.</i>	54.28 mm
		Stroke <i>Course</i>	54 mm
		Cooling system <i>Système de refroidissement</i>	Water <i>À Eau</i>
		Inlet system <i>Système d' admission</i>	Reed valve <i>À clapets</i>
		Cylinder / crankcase transfers n° <i>N° de canaux cylindre / carter</i>	3 / 3
Carburetor Tillotson <i>Carburateur Tillotson</i>	HW-27A (Ø27 Venturi)	Inlet / exhaust ports number <i>N° lumières admiss. / échapp.</i>	3 / 3
Number of piston rings <i>Nombre de segments</i>	1	Combustion chamber shape <i>Forme chambre de combustion</i>	Spherical <i>Sphérique</i>
Big end conr. bearing diam. <i>Diamètre roulement tête de bielle</i>	20x26x15	Selettra or PVL ignition <i>Allumage Selettra ou PVL</i>	Digital
Crankshaft bearing diam. <i>Diamètre roulement du vilebrequin</i>	30x62x16	Distance between conrod centers <i>Longueur (entraxe) de la bielle</i>	102 mm
Small end conr. bearing diam. <i>Diamètre roulement pied de bielle</i>	14x18x17.5	RPM limiter <i>Limiteur de régime</i>	Yes <i>Oui</i>
Balancing shaft <i>Arbre d'équilibrage</i>	Yes <i>Oui</i>	Electric starter <i>Démarrreur électrique</i>	Yes <i>Oui</i>

DESCRIPTION OF THE MATERIAL DESCRIPTION DES MATERIAUX		PISTON	
Conrod material <i>Matériau de la bielle</i>	Steel <i>Acier</i>	 <p>Piston min. weight (ring incl.) 128 g Poids min. piston (avec segment) 128g</p>	
Crankshaft material <i>Matériau du vilebrequin</i>	Steel <i>Acier</i>		
Balancing shaft material <i>Matériau de l'arbre d'équilibrage</i>	Steel <i>Acier</i>		
Gears material <i>Matériau des engrenages</i>	Steel <i>Acier</i>		
Starter ring material <i>Matériau de la couronne démarreur</i>	Steel <i>Acier</i>		
Head material <i>Matériau de la culasse</i>	Aluminium		DISTANCE BETWEEN CONROD CENTERS ENTRAXE DE LA BIELLE
Cylinder material <i>Matériau du cylindre</i>	Aluminium	 <p>Min. weight 110 g Poids min. 110 g</p>	
Liner material <i>Matériau de la chemise</i>	Iron <i>Fonte</i>		
Crankcase material <i>Matériau du carter</i>	Aluminium		
Piston material <i>Matériau du piston</i>	Aluminium		
Piston rings material <i>Matériau des segments</i>	Iron <i>Fonte</i>		
Exhaust muffler material <i>Matériau du pot d'échappement</i>	Sheet-steel <i>Tôle acier</i>		
Ball-bearings <i>Roulements</i>	Type 6206		
CRANKSHAFT - VILEBREQUIN			BALANCING SHAFT ARBRE D'EQUILIBRAGE
 <p>Piston pin min. weight 28 g Poids min. axe de piston 28 g</p> <p>Crankpin min. weight 116 g Poids min. axe de vilebrequin 116 g</p> <p>49.8^{+0.2}/_{-0.1} Bearing Seat Distance Distance du siège de roulement</p> <p>Complete crankshaft min. weight 2150 g Poids min. du vilebrequin complet 2150 g</p>			 <p>Min. weight 315 g Poids Min. 315 g</p>
			CRANKSHAFT BALL BEARINGS ROULEMENTS À BILLES DU VILEBREQUIN
		 <p>Ø30.02 max</p>	

DIMENSIONS OF ALTERNATIVE CRANKSHAFT WITH ROLLER MAIN BEARINGS
DIMENSIONS DU VILEBREQUIN ALTERNATIF AVEC ROULEMENTS A ROULEAUX

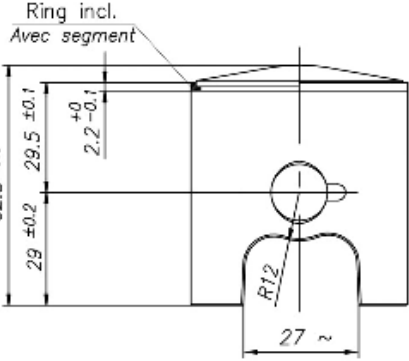
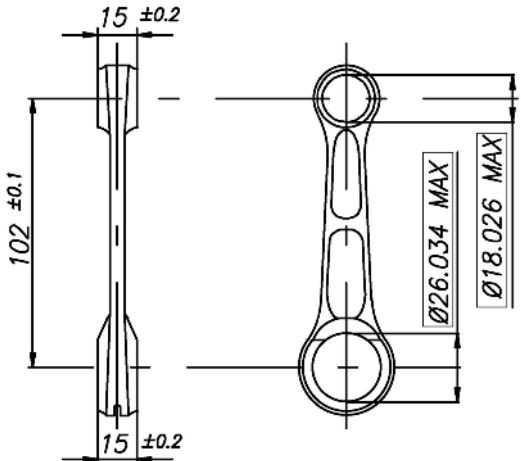
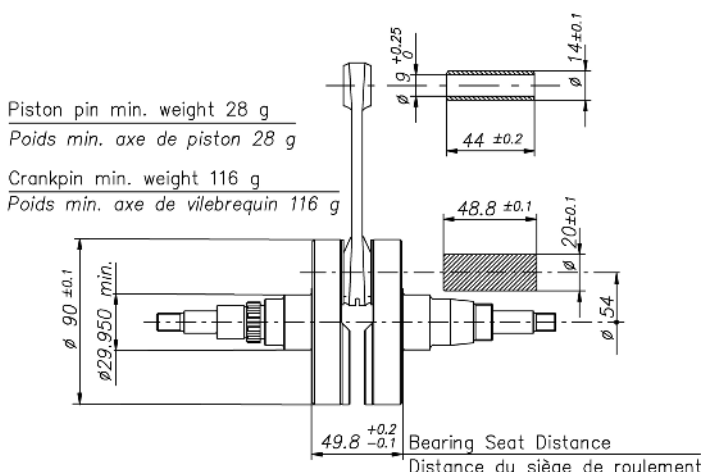
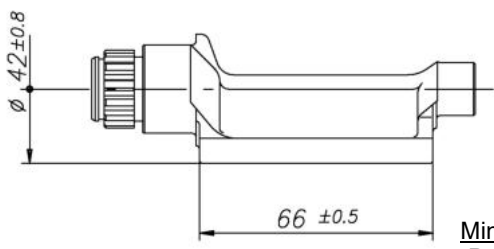
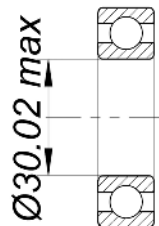
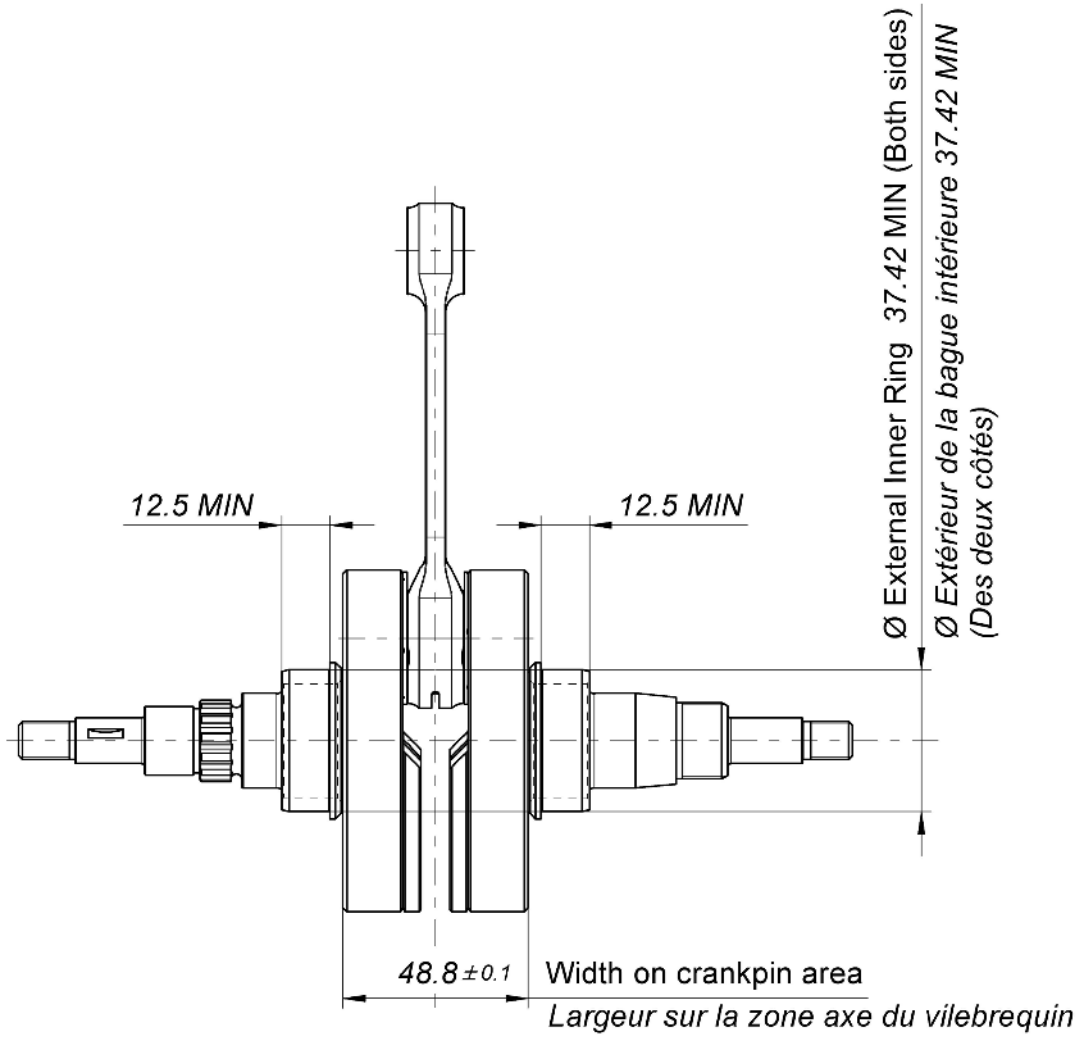

Crankshaft complete min. Weight 2220 g
Poids min. du vilebrequin

ROLLER MAIN BEARING
ROULEMENTS À ROULEAUX DU VILEBREQUIN

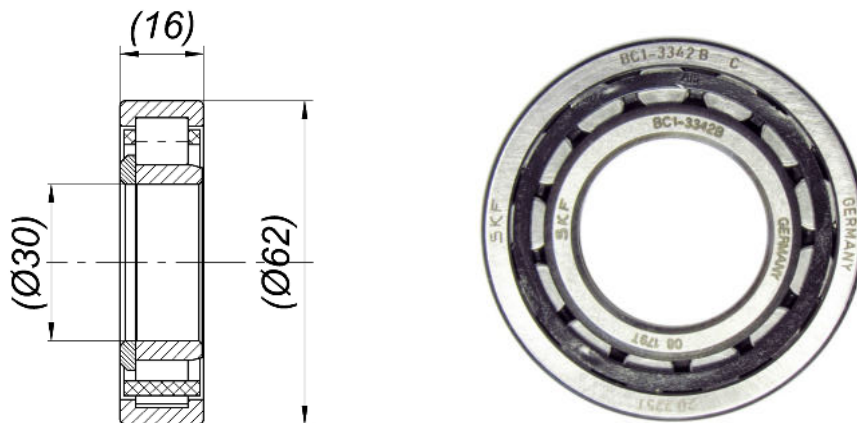

CYLINDER DEVELOPMENT - DEVELOPPEMENT DU CYLINDRE

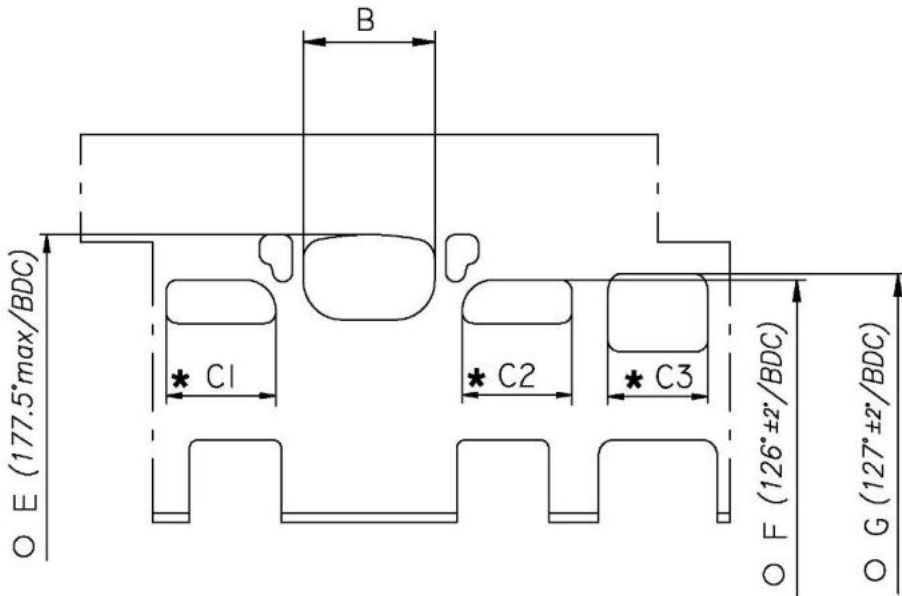

B	≤ 36.5 mm
C1 = C2	≤ 30 mm
C3	≤ 28.5 mm
E	177.5° max
F	126° ± 2°
G	127° ± 2°

*** CHORDAL READING**
LECTURE CORDALE

○ ANGULAR READING BY INSERTING A 0.2x5 mm GAUGE
LECTURE ANGULAIRE PAR INSERTION D'UNE CALE DE 0.2x5 mm

CYLINDER BASE VIEW
VUE DE LA BASE DU CYLINDRE

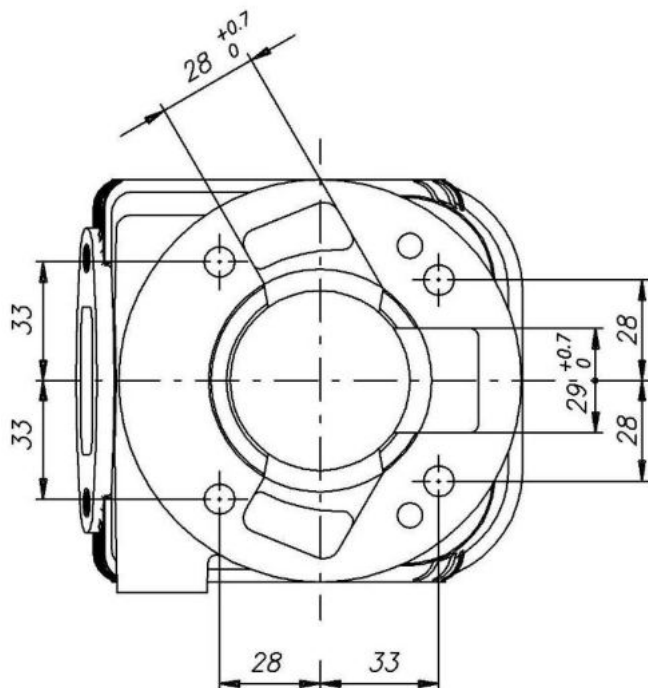

CYLINDER CROSS SECTION VIEW
VUE EN SECTION DU CYLINDRE

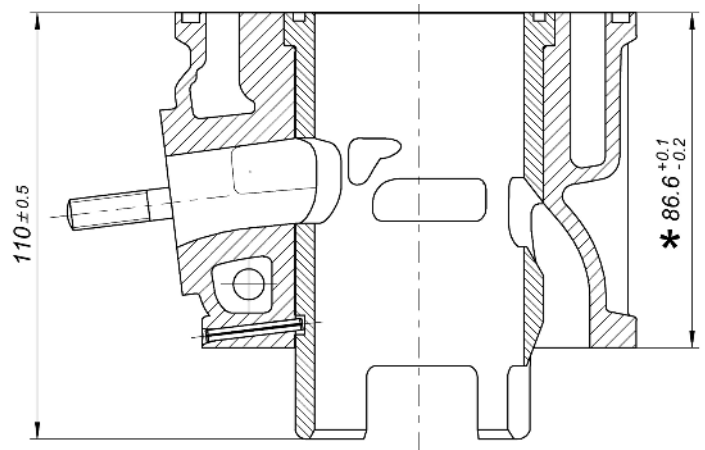

***** from the base plane of the cylinder
to the top plane of the liner
à partir du plan de base du cylindre
jusqu'au plan supérieur de la chemise

COMBUSTION CHAMBER VIEW
VUE DE LA CHAMBRE DE COMBUSTION

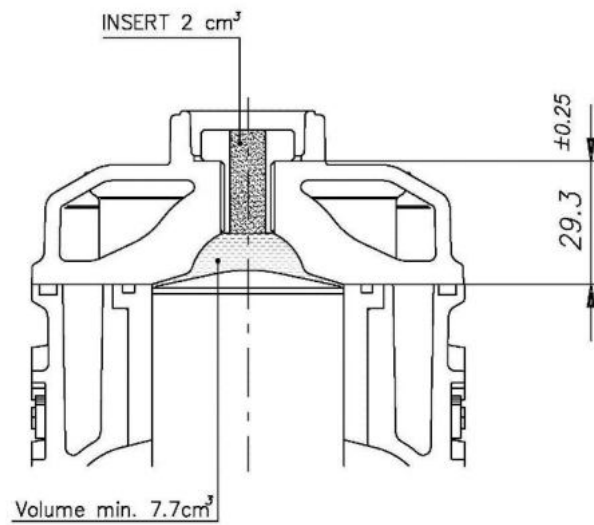

COMBUSTION CHAMBER VOLUME TOT. = 9.7 cm³ min.
VOLUME CHAMBRE COMBUSTION TOT. = 9.7 cm³ min.

ATT. : SQUISH MIN. = 0.90 mm
(measured with Ø1.5mm TIN - mesurée avec de l'étain Ø1.5mm)

CRANKCASE INSIDE VIEW
VUE A' L' INTERIEUR DU CARTER

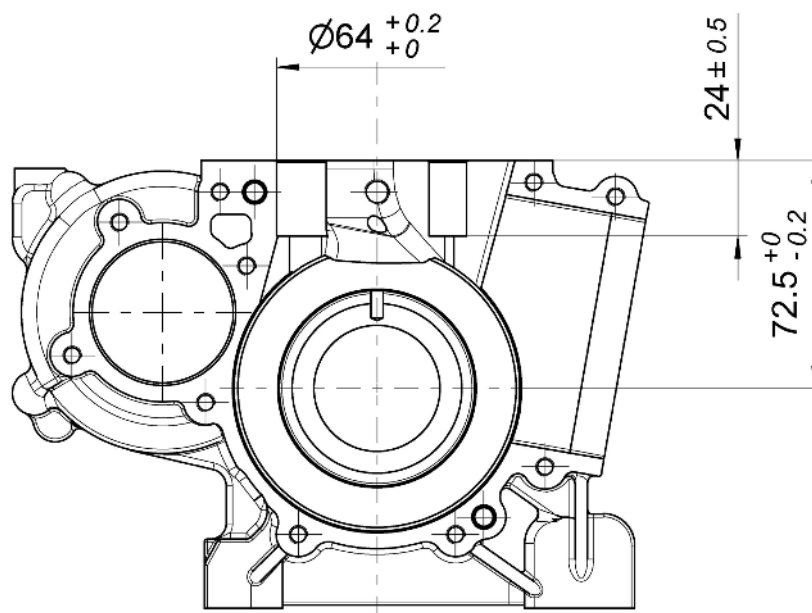

TILLOTSON HW-27A VENTURI CARBURETTOR DIMENSIONS
 DIMENSIONS DU VENTURI DU CARBURATEUR TILLOTSON HW-27A

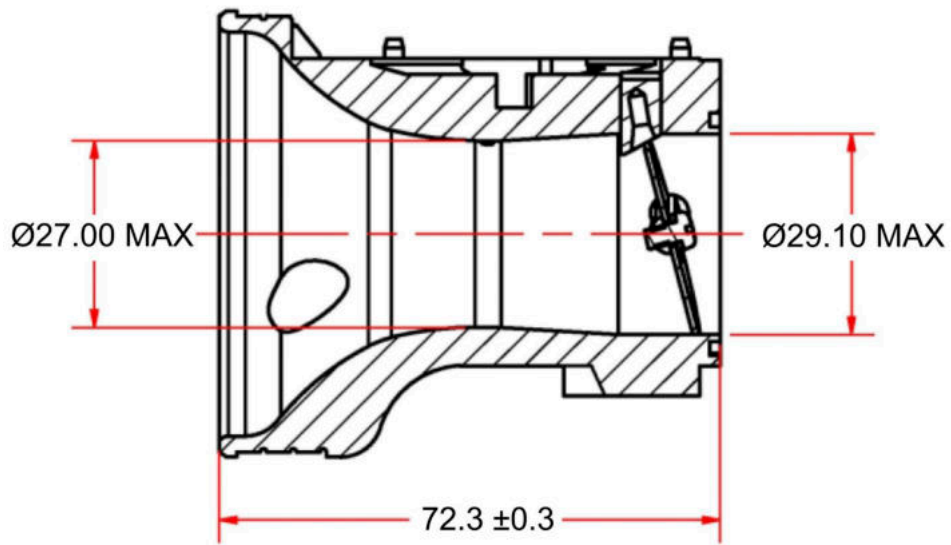

INLET CONVEYOR DIMENSIONS
 CONVOYEUR D'ADMISSION

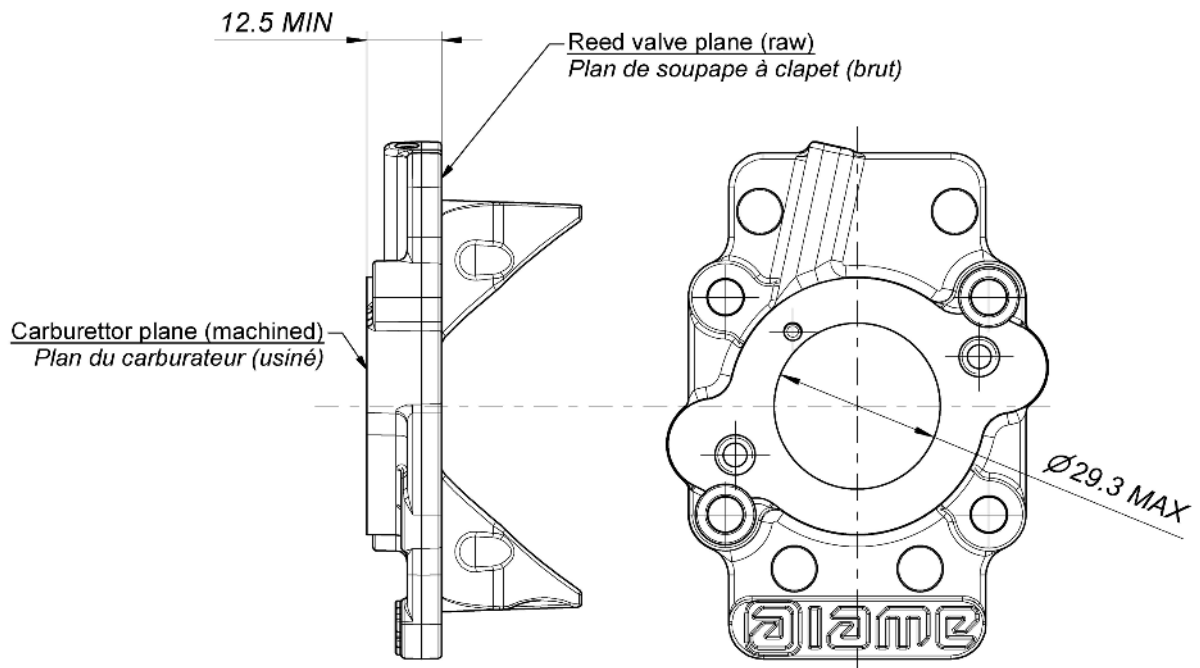

REED VALVE - DIMENSIONS AND MARKING
BOÎTE À CLAPETS - DIMENSIONS ET MARQUAGE

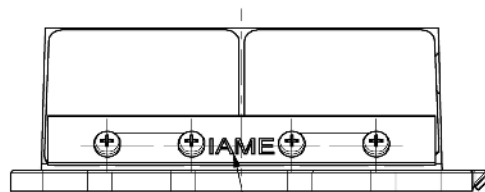
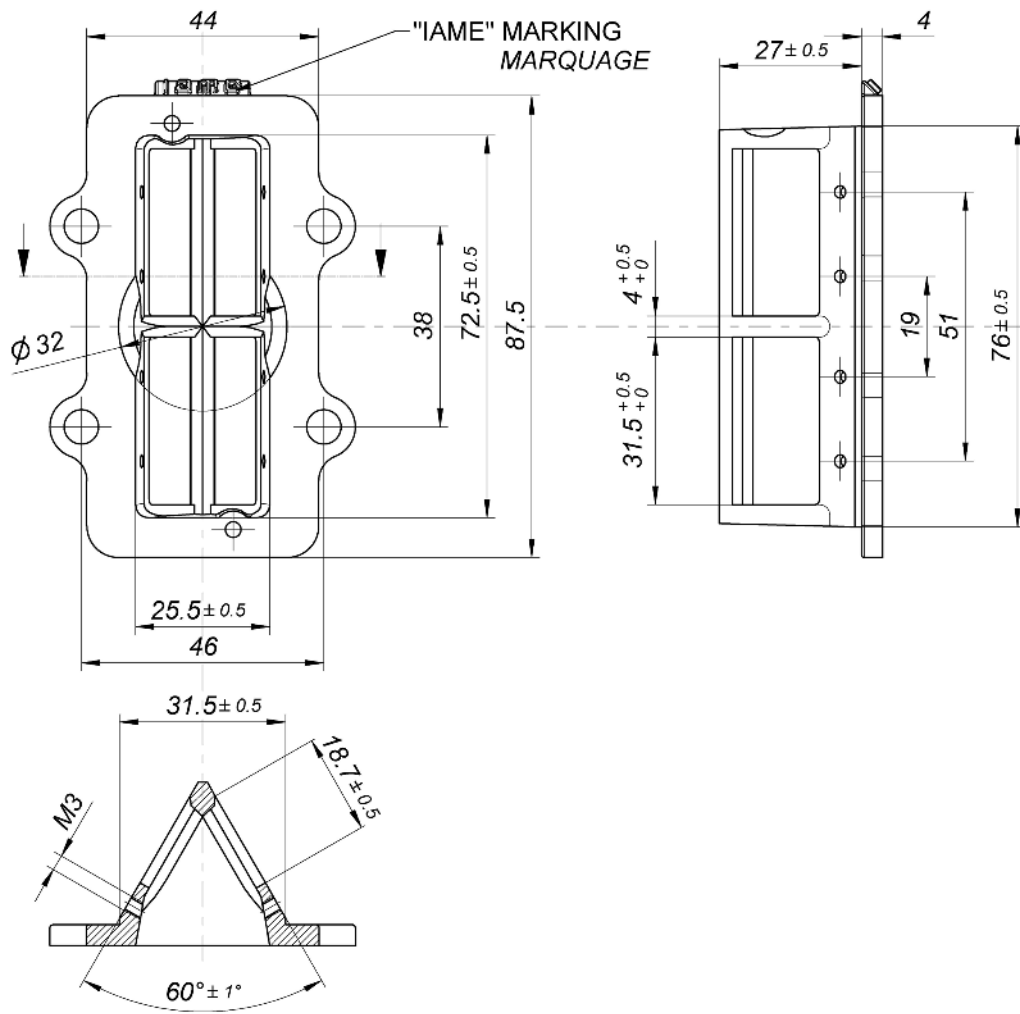

"IAME"
MARKING / MARQUAGE

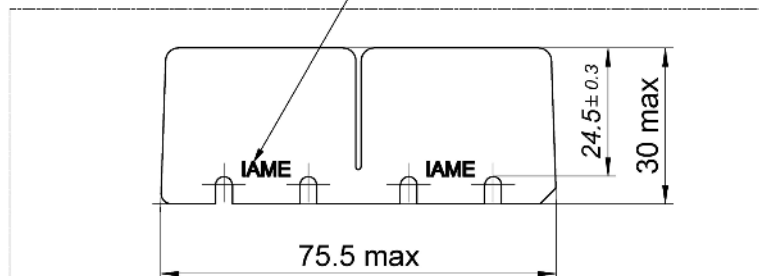

Genuine IAME vetronite reeds min. thickness 0.30mm
Clapets IAME authentique en fibre de verre 0.30mm épaisseur mini

Genuine IAME carbon fiber reeds min. thickness 0.24mm
Clapets IAME authentique en fibre de carbone 0.24mm épaisseur mini

INLET SILENCER – DRAWING
DESSIN DU SILENCIEUX D'ADMISSION

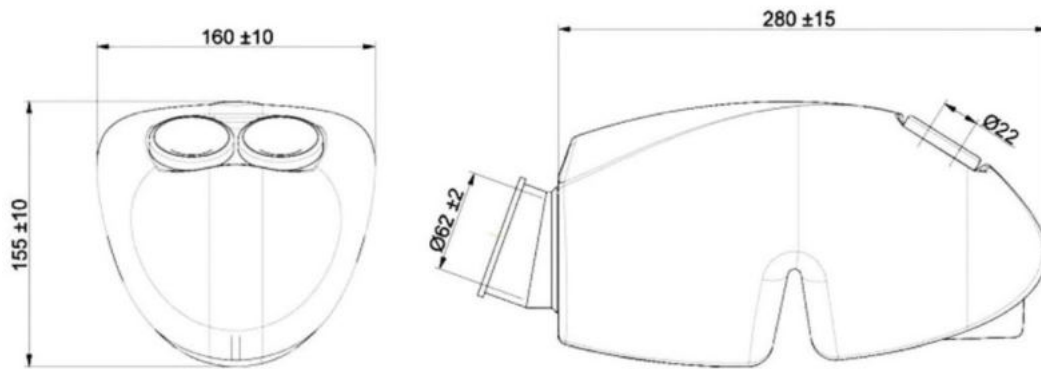

WITH SPONGE AIR FILTER
AVEC MANCHON COMPLET ET FILTRE À AIR

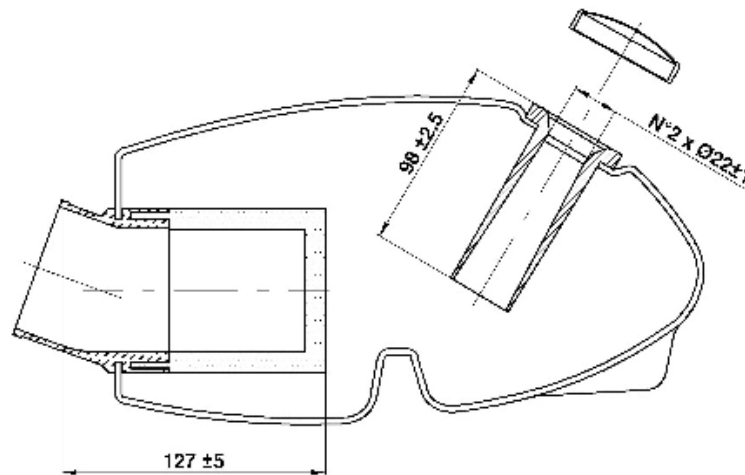

INLET SILENCER - PHOTO
PHOTO - SILENCIEUX D'ADMISSION



RAIN COVER INLET SILENCER – DRAWING
DESSIN DU COUVERTURE POUR LA PLUIE DU SILENCIEUX D'ADMISSION

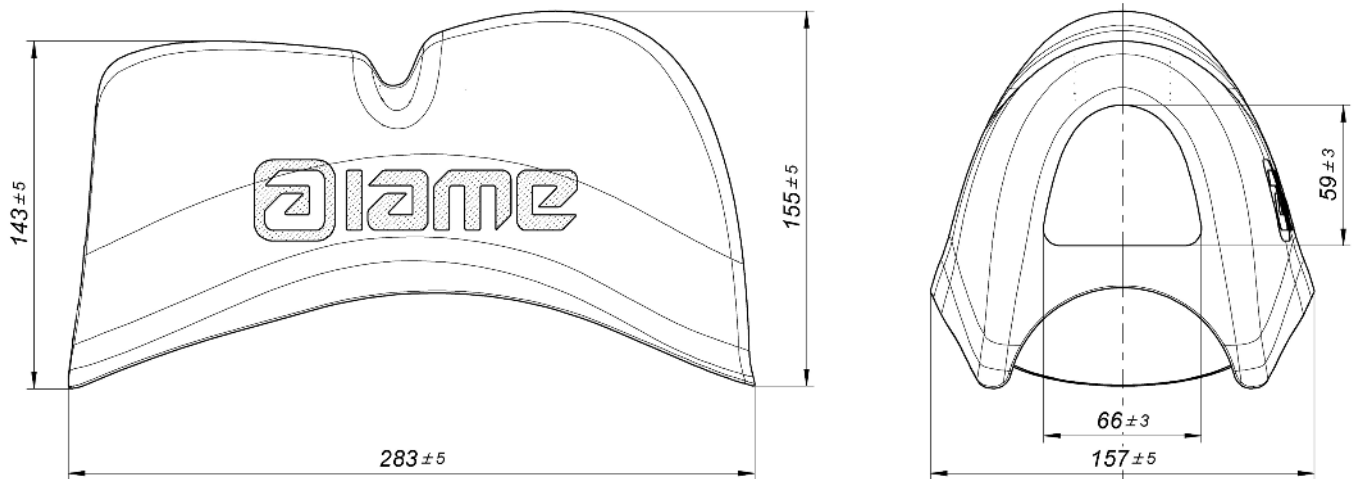

RAIN COVER INLET SILENCER - PHOTO
PHOTO - COUVERTURE POUR LA PLUIE DU SILENCIEUX D'ADMISSION



DESCRIPTION OF THE CLUTCH - DESCRIPTION DE L'EMBRAYAGE

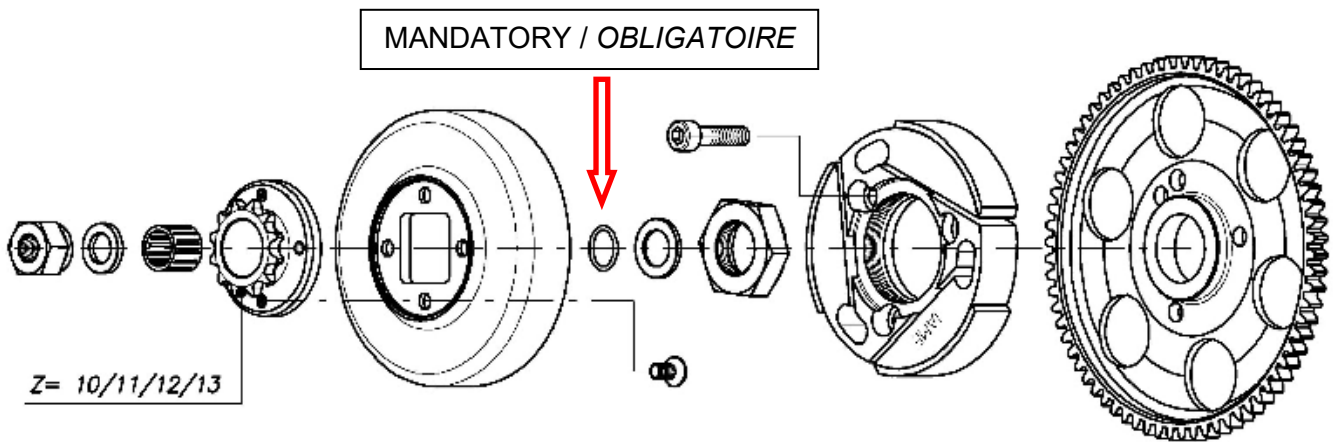

COMPONENTS OF THE CLUTCH – COMPOSANTS DE L'EMBRAYAGE

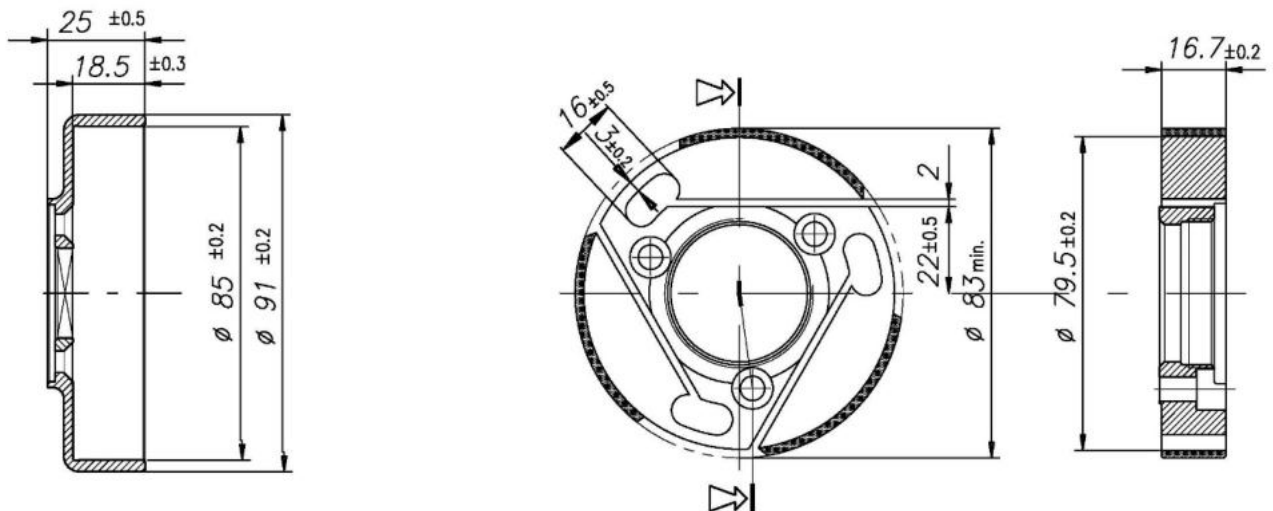

Min. weight 225 g
Poids min. 225g

Min. weight 375 g
Poids min. 375g

EXHAUST MUFFLER VIEW AND DIMENSIONS
VUE ET DIMENSIONS DU SILENCIEUX D'ÉCHAPPEMENT

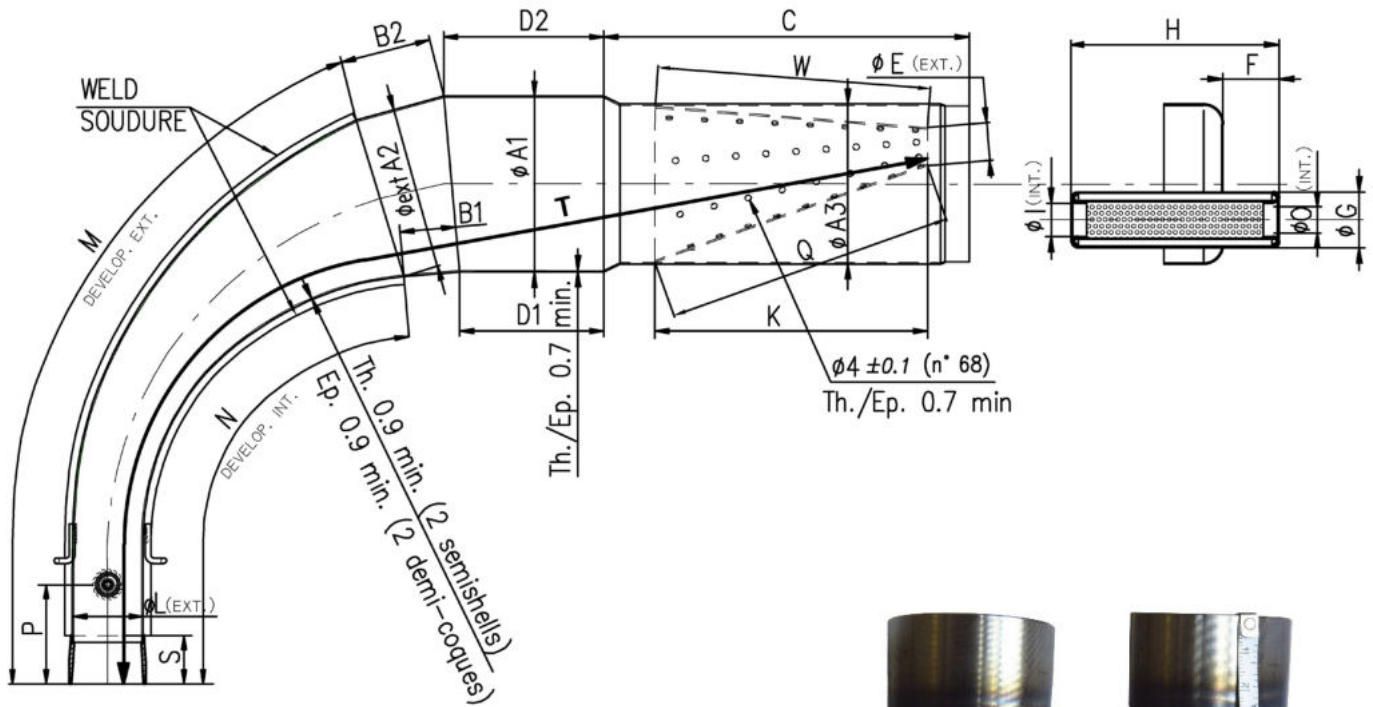

The tape must follow the centerline of the weld at all points.

Le ruban doit suivre l'axe de la soudure en tous points.

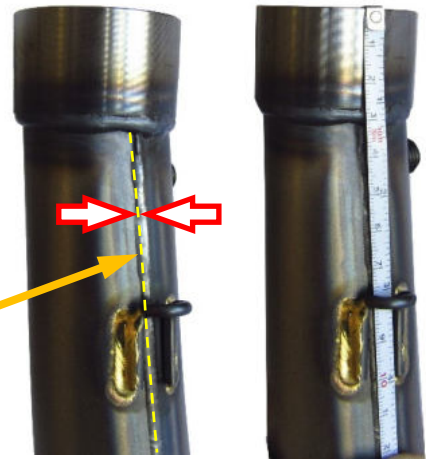

Min. Weight 1.780 g
Poids min. 1.780 g

ØA1: 110 ±1.5 Øext.	B2: 60 ±3	ØE: 23.5 ±2 Øext.	ØI: 21 ±1 Øint.	N: 341 ±3	T: 690 ±3
ØA2: 102 ±1.5 Øext.	C: 219 ±3	F: 36 ±2	K: 170 ±3	ØO: 21 ±1 Øint.	W: 170 ±3
ØA3: 100 ±1.5 Øext.	D1: 90 ±3	ØG: 35 ±1 Øext.	ØL: 42.5 ±1.5 Øext.	P: 50 ±10	Q: 182 ±3
B1: 60 ±3	D2: 109 ±3	H: 132 ±3	M: 439 ±3	S: 29 ±1.5	

ATTENTION:

The dimensions "M", "N" and "T" must be taken by steel tape measure 6mm wide.
The dimensions "M" and "N" must be taken on the weld centerline.

Les dimensions « M », « N » et « T » doivent être prises à l'aide d'un ruban à mesurer en acier 6 mm de large.

Les dimensions « M », « N » doivent être prises sur l'axe de la soudure.

The dimensions "Q" and "W" must be taken by steel tape measure 12mm wide.

Les dimensions « Q » et « W » doivent être prises à l'aide d'un ruban à mesurer en acier 12 mm de large.

SENIOR EXHAUST FITTING
RACCORD D'ÉCHAPPEMENT SENIOR

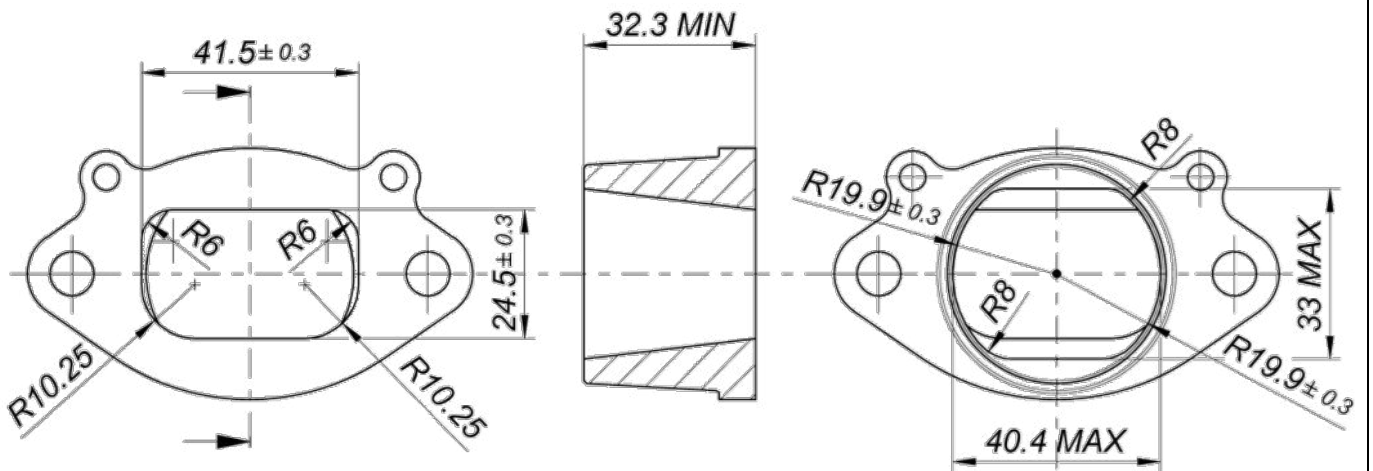

SENIOR EXHAUST INSTALLATION
INSTALLATION DE L'ÉCHAPPEMENT SENIOR

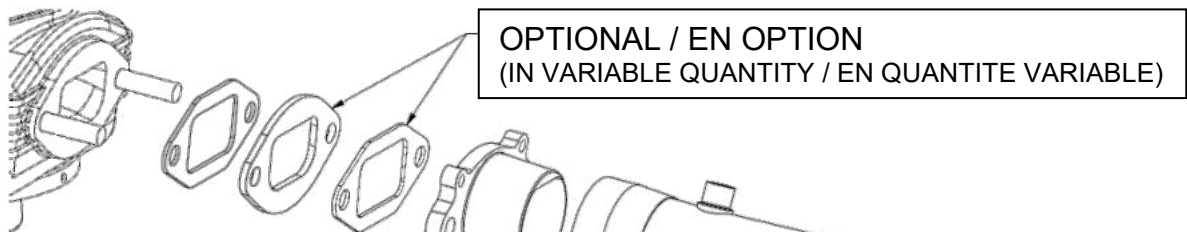

OPTIONAL / EN OPTION
Part n° cod. X30125375

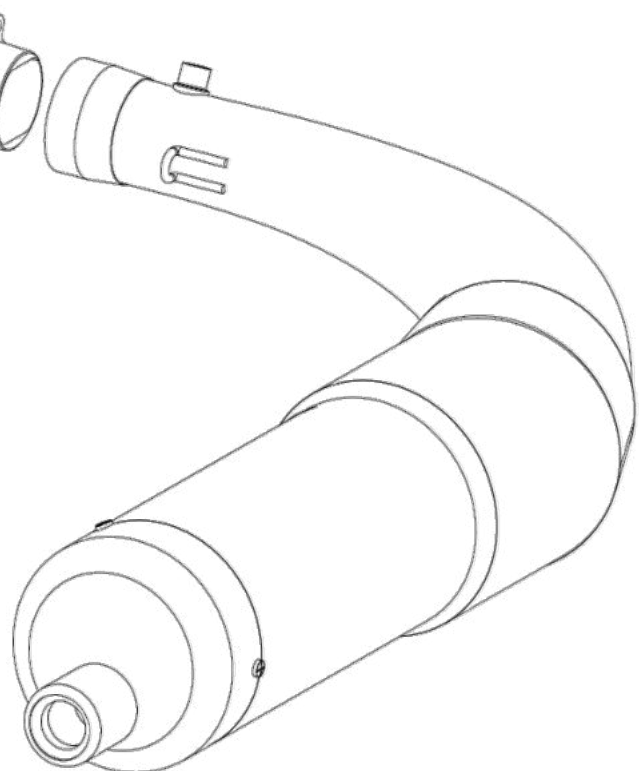
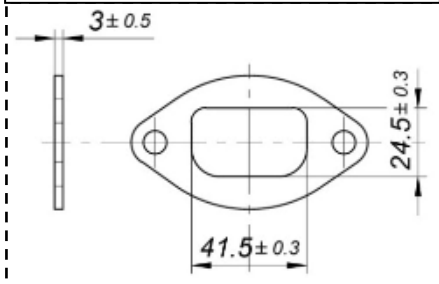

EXHAUST FITTING WITH Ø24 RESTRICTOR
 RACCORD D'ÉCHAPPEMENT AVEC RESTRICTEUR Ø24

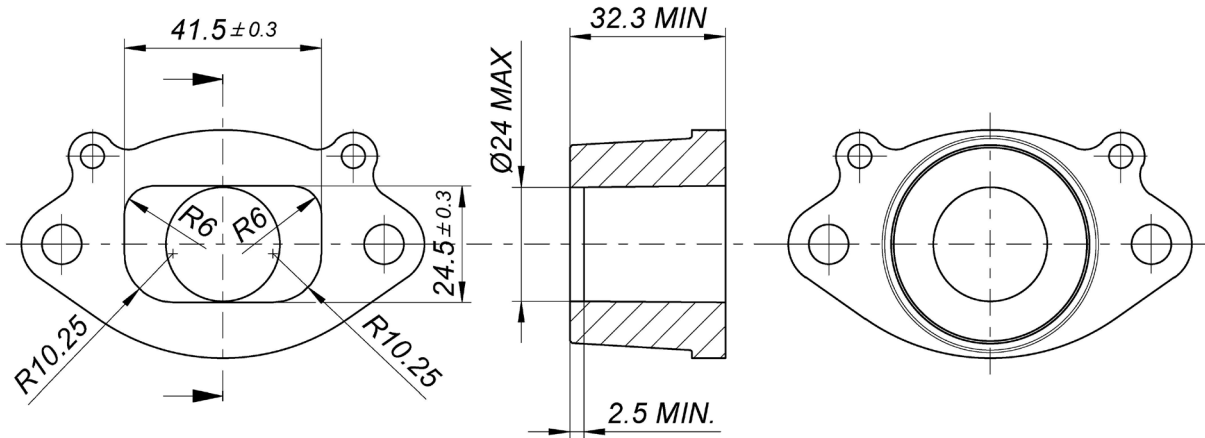

EXHAUST FITTING WITH Ø24 RESTRICTOR MARKING
 MARQUAGE D'IDENTIFICATION DU RACCORD D'ÉCHAPPEMENT AVEC RESTR. Ø24



EXHAUST WITH Ø24 RESTRICTOR INSTALLATION
 INSTALLATION DE L'ÉCHAPPEMENT AVEC RESTRICTEUR Ø24

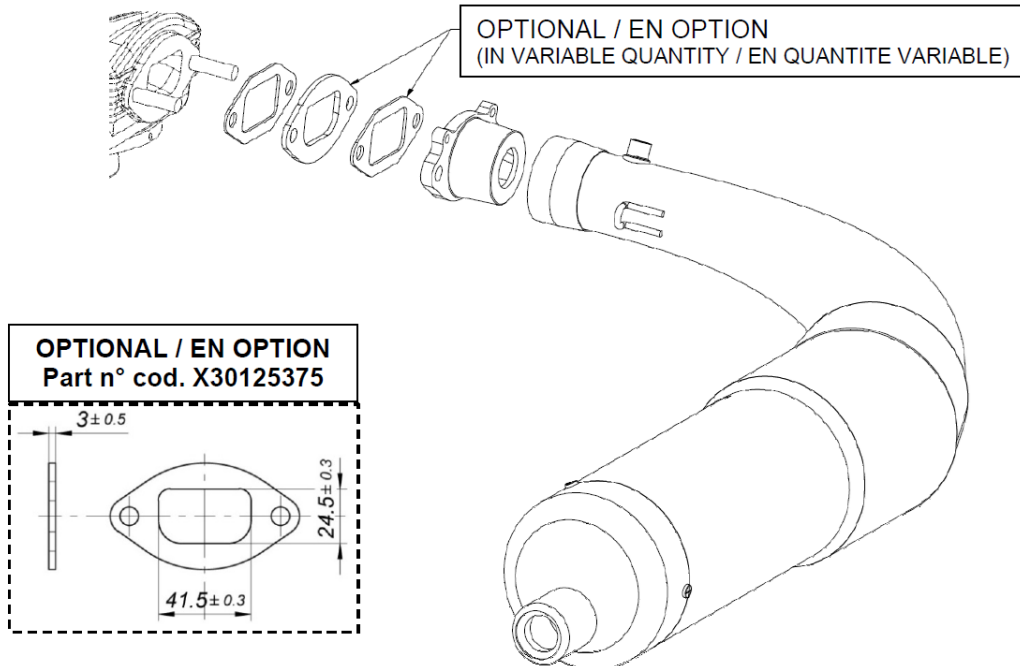

WIRING DIAGRAM (SELETTRA DIGITAL "K" IGNITION)
 SCHEMA CIRCUIT ELECTRIQUE (ALLUMAGE SELETTRA DIGITAL "K")

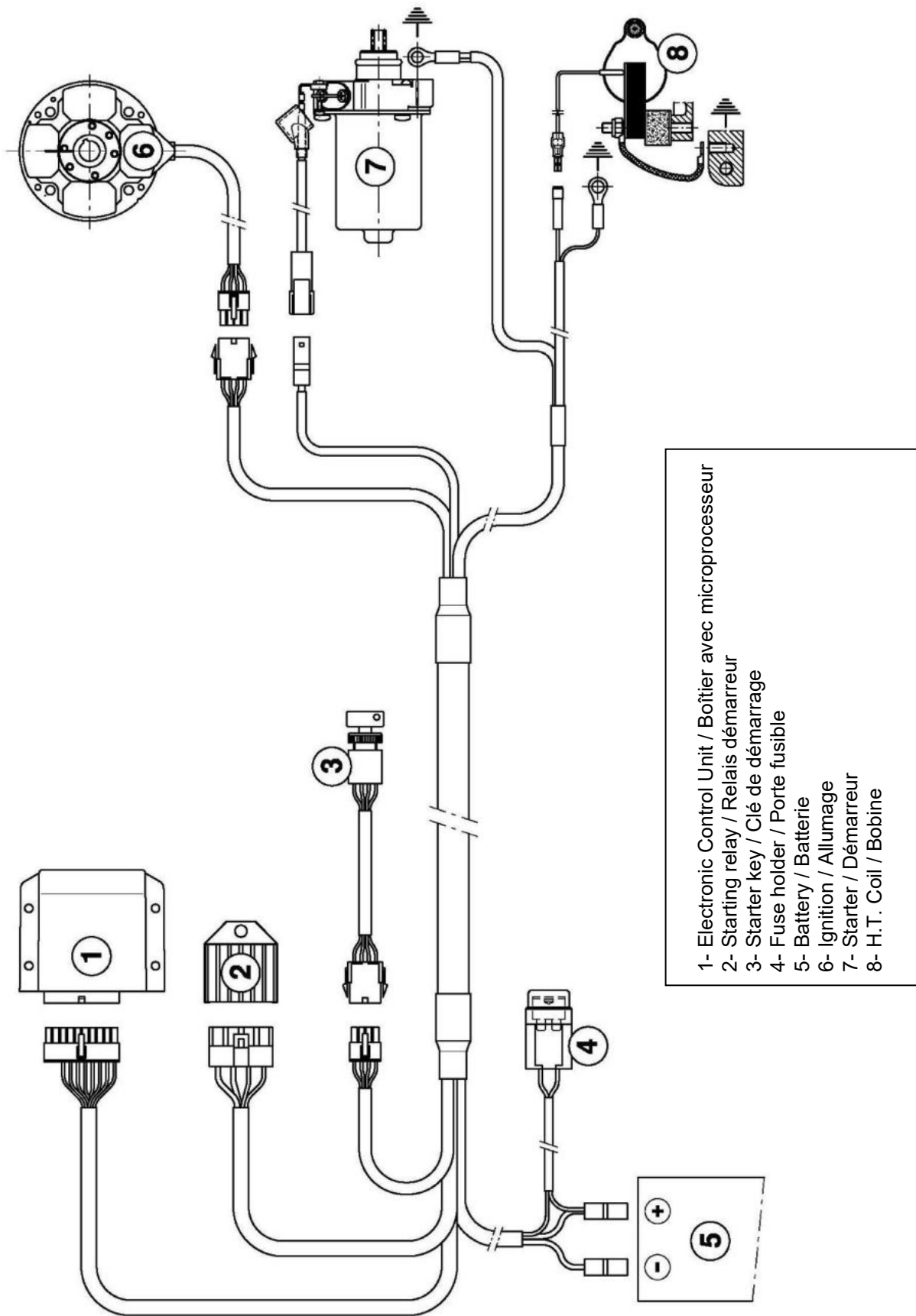

- 1- Electronic Control Unit / Boîtier avec microprocesseur
- 2- Starting relay / Relais démarrage
- 3- Starter key / Clé de démarrage
- 4- Fuse holder / Porte fusible
- 5- Battery / Batterie
- 6- Ignition / Allumage
- 7- Starter / Démarreur
- 8- H.T. Coil / Bobine

SCHEME FOR ADVANCE CONTROL
 SCHEMA POUR LE CONTROLE DE L'AVANCE

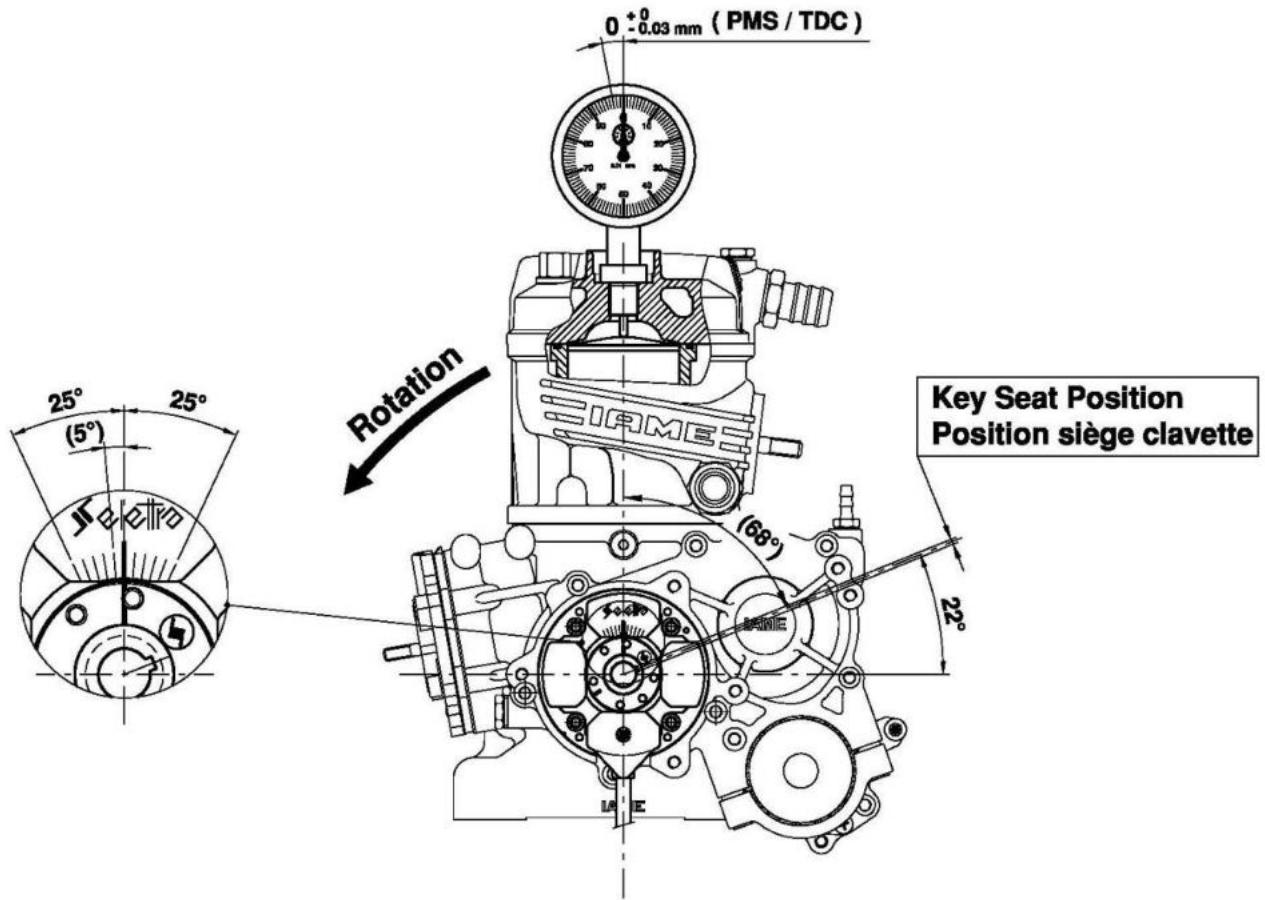

ADVANCE CURVE GRAPHS / GRAPHIQUES DE LA COURBE D'AVANCE

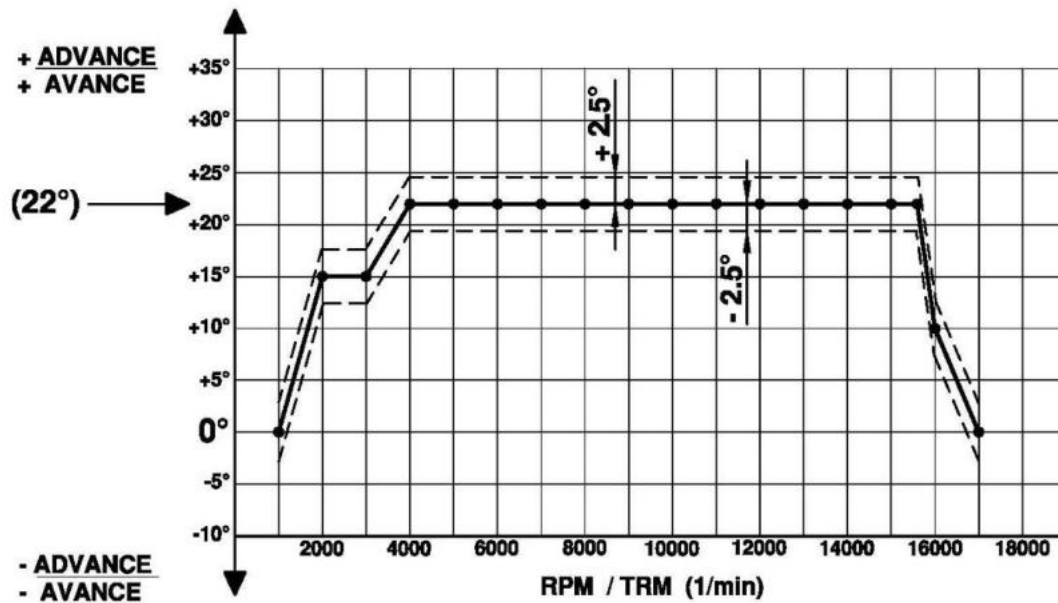

ELECTRONIC BOX MARKING
MARQUAGE DU BOITIER ELECTRONIQUE

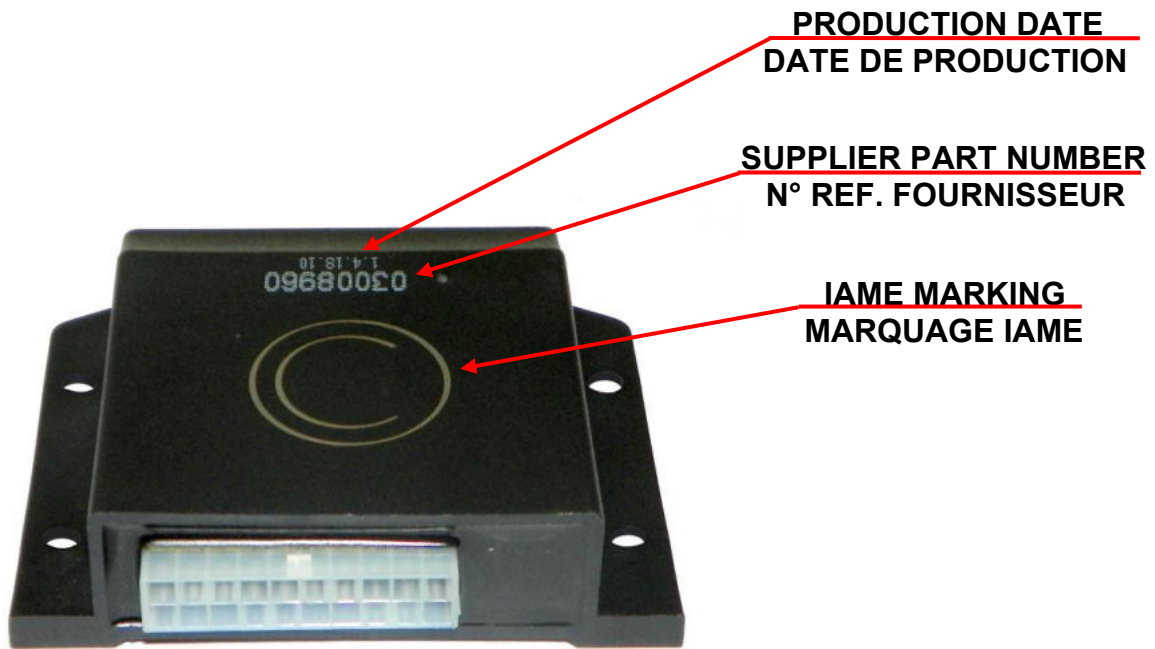

GEAR ALTERNATIVE FIXING
FIXATION ALTERNATIVE DE L'ENGRENAGE

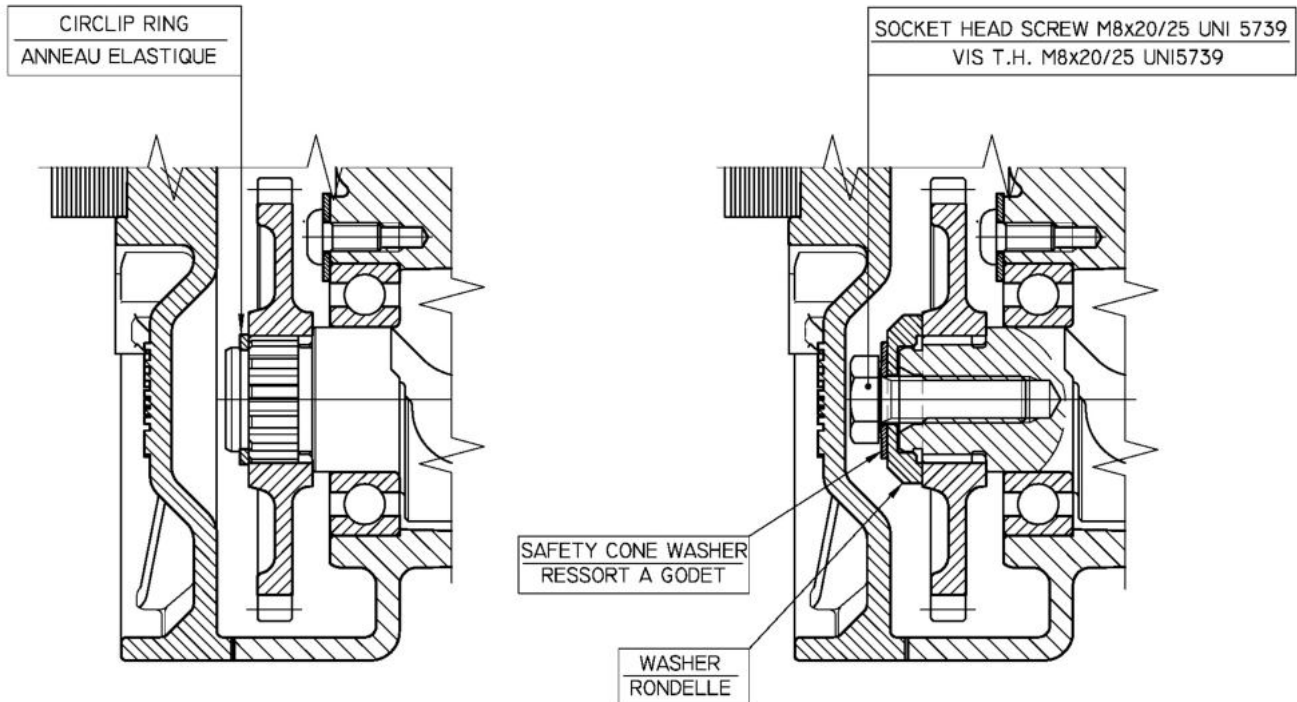

DESCRIPTION OF THE CLUTCH - *DESCRIPTION DE L' EMBRAYAGE*

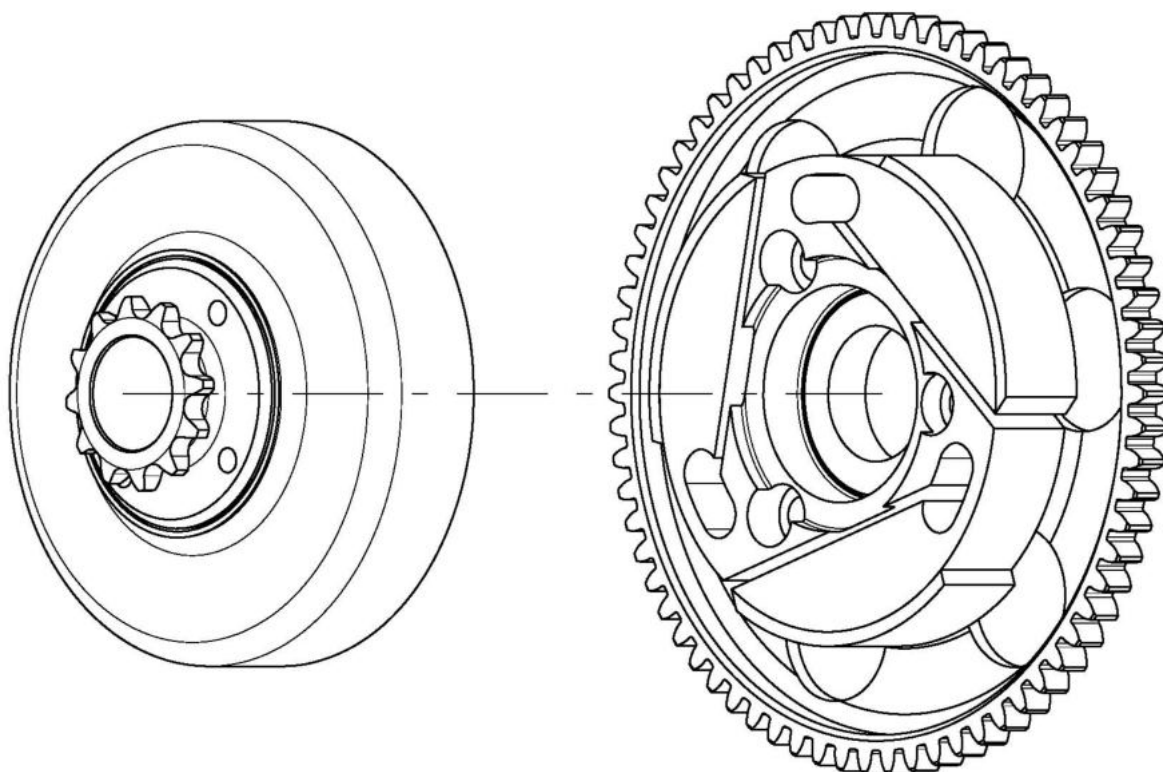

Min. weight 300 g
Poids min. 300 g

Min. weight 680 g
Poids min. 680 g

RADIATOR DESCRIPTION AND SKETCH OF PARTS
 DESCRIPTION DU RADIATEUR ET SCHEMA ILLUSTRANT LES ELEMENTS

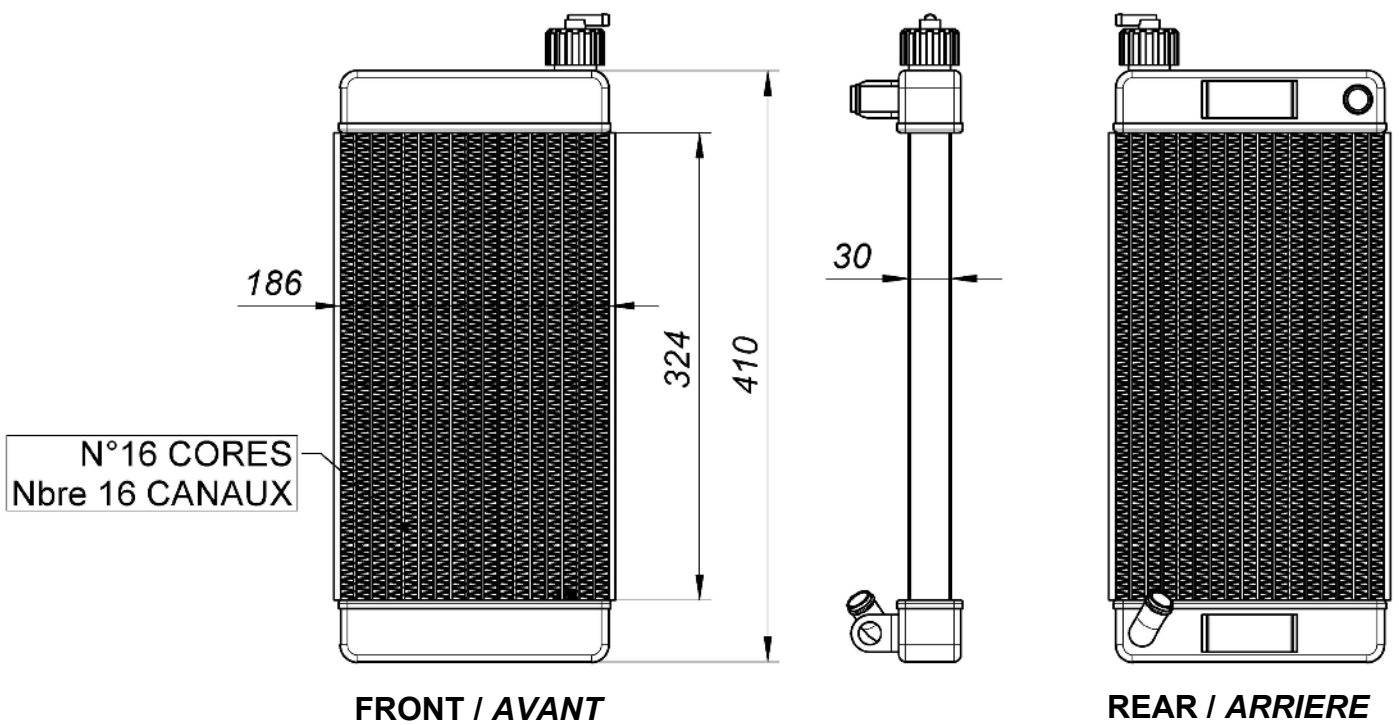

PAINTED AND NOT PAINTED
PEINT ET PAS PEINT

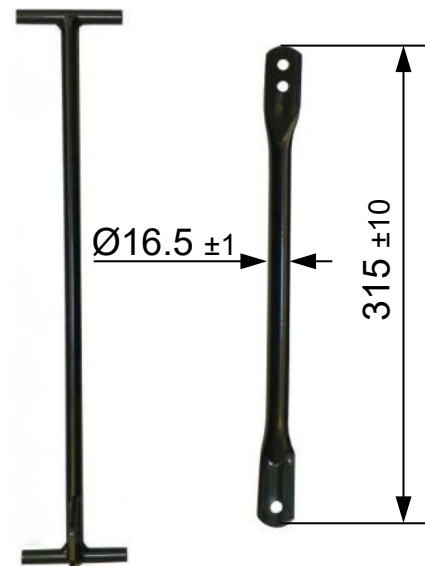

RADIATOR ALTERNATIVE DESCRIPTION AND SKETCH
 DESCRIPTION DU RADIATEUR ALTERNATIF

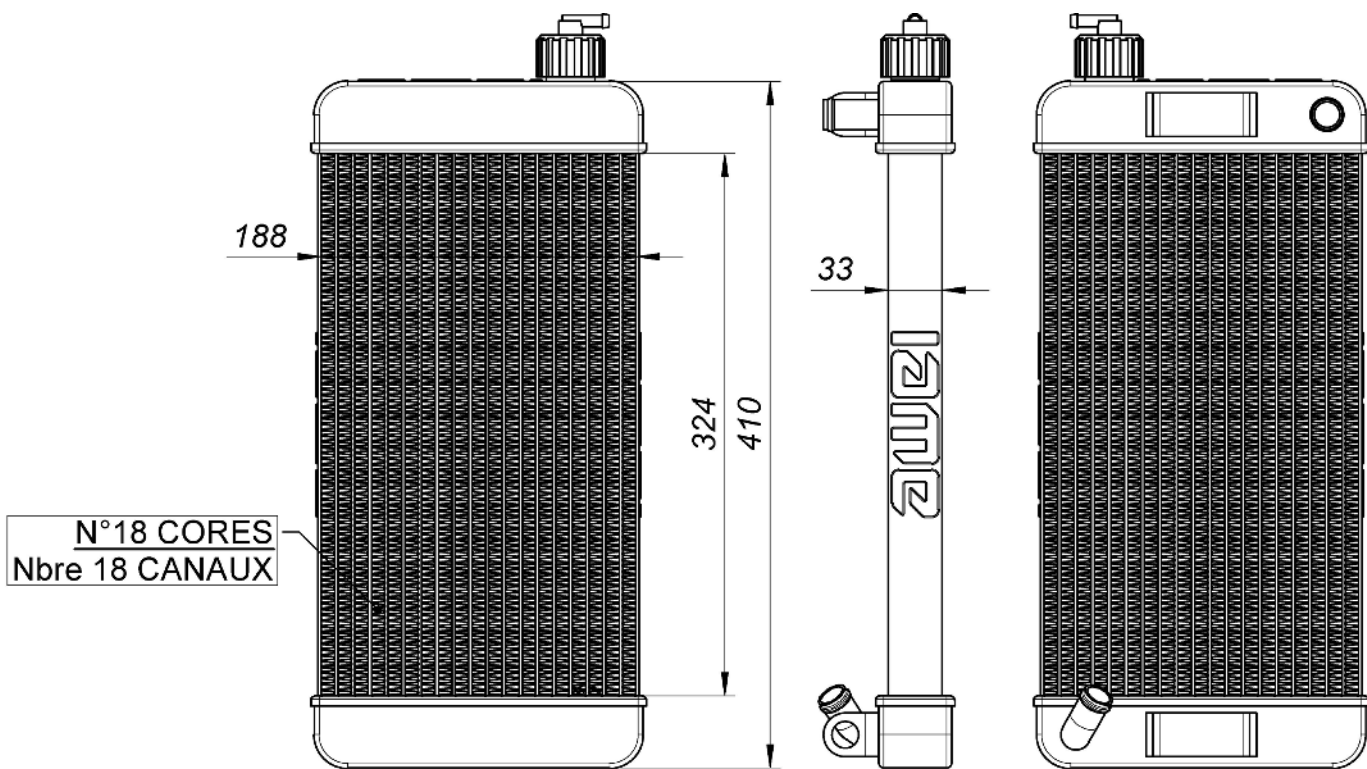

FRONT / AVANT

REAR / ARRIERE



FRONT / AVANT

REAR / ARRIERE



RADIATOR ALTERNATIVE DESCRIPTION AND SKETCH
 DESCRIPTION DU RADIATEUR ALTERNATIF

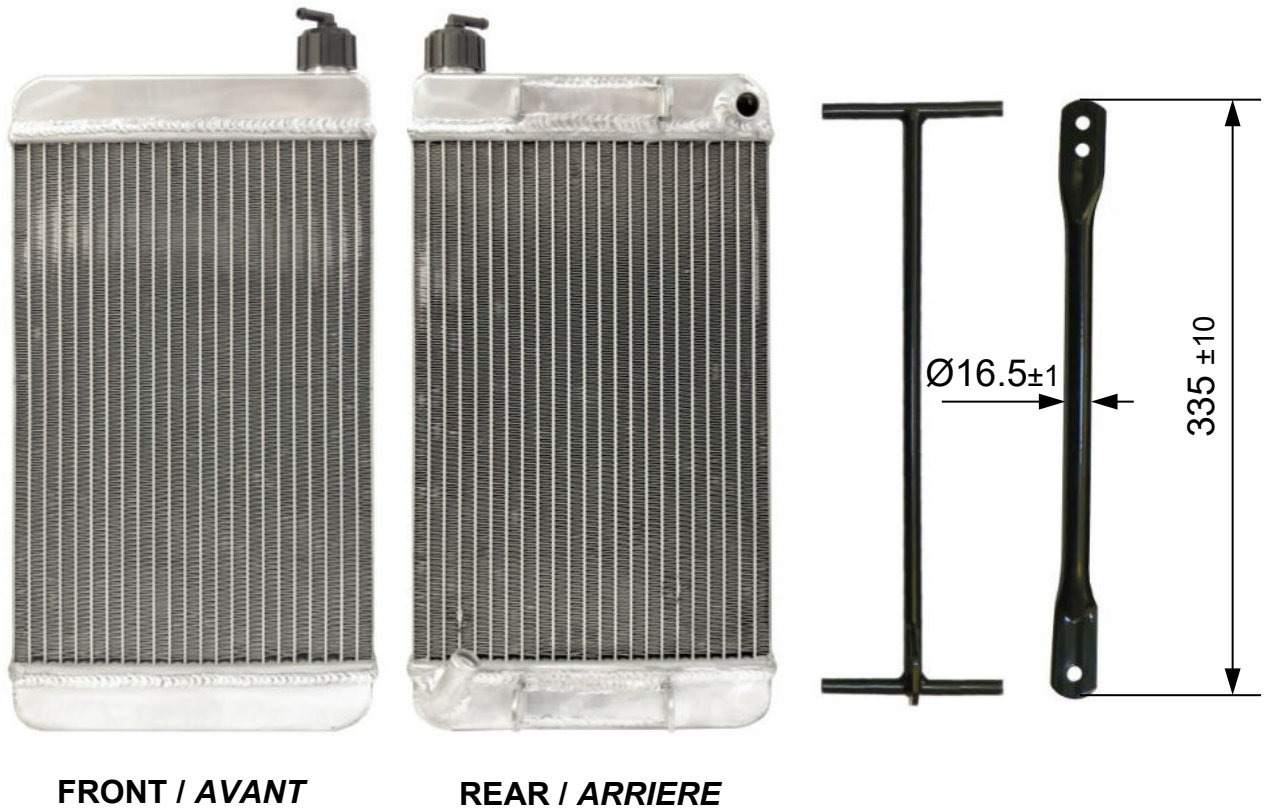
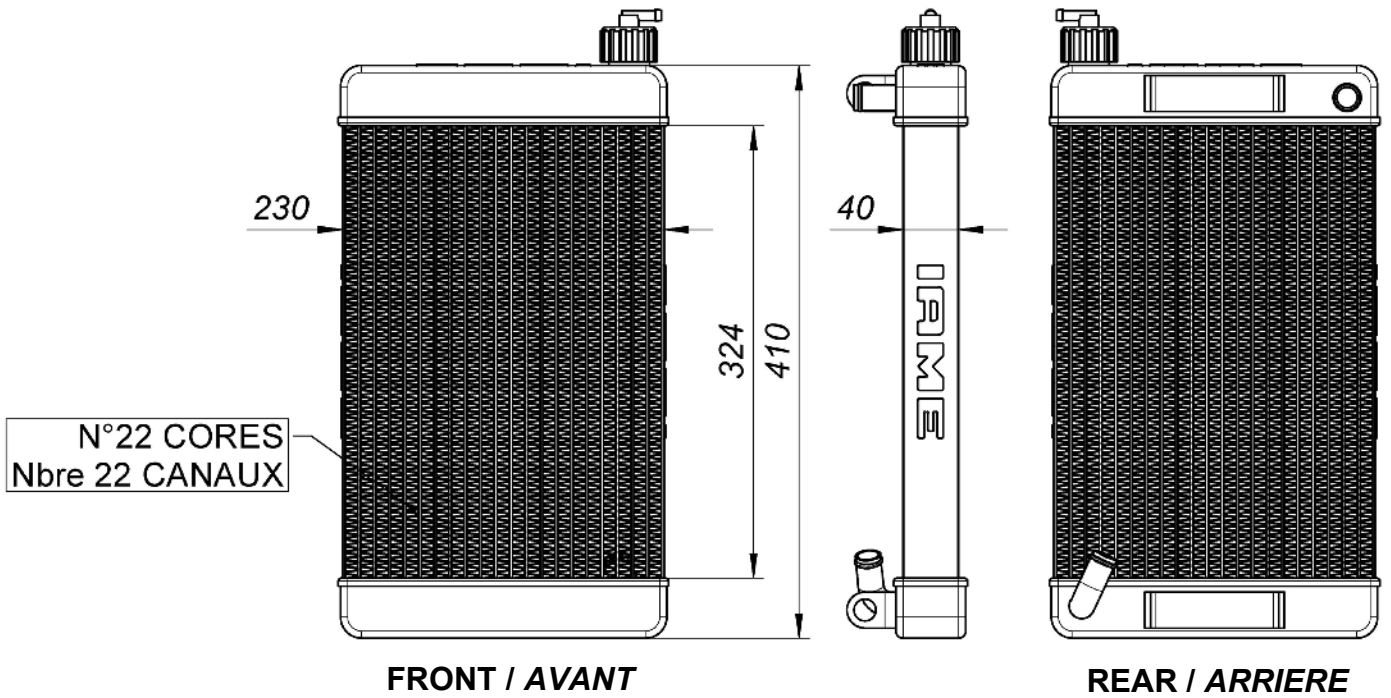

RADIATOR AND ITS SUPPORTS
 RADIATEUR ET SES SUPPORTS

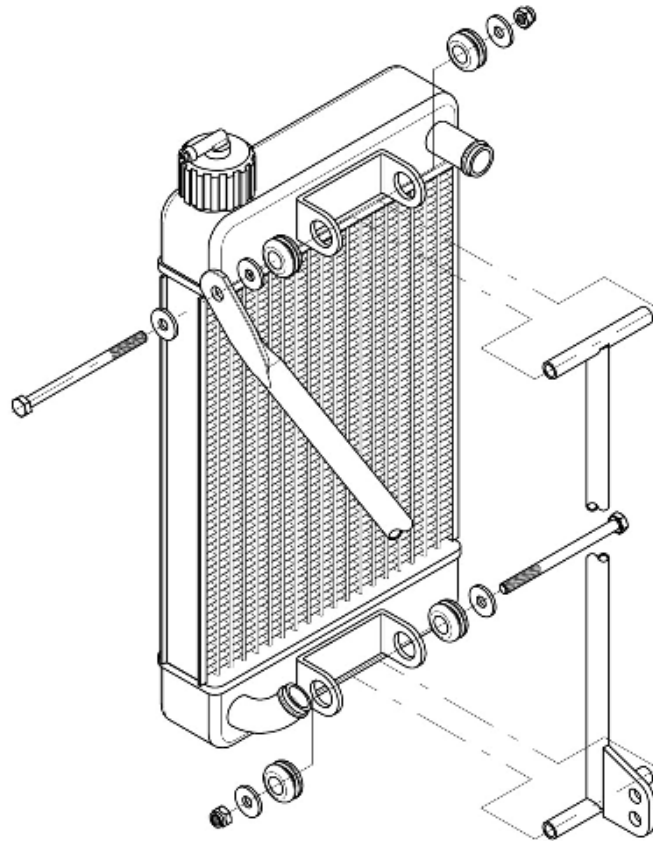

WATER PUMP GROUP
 GROUPE POMPE A' EAU

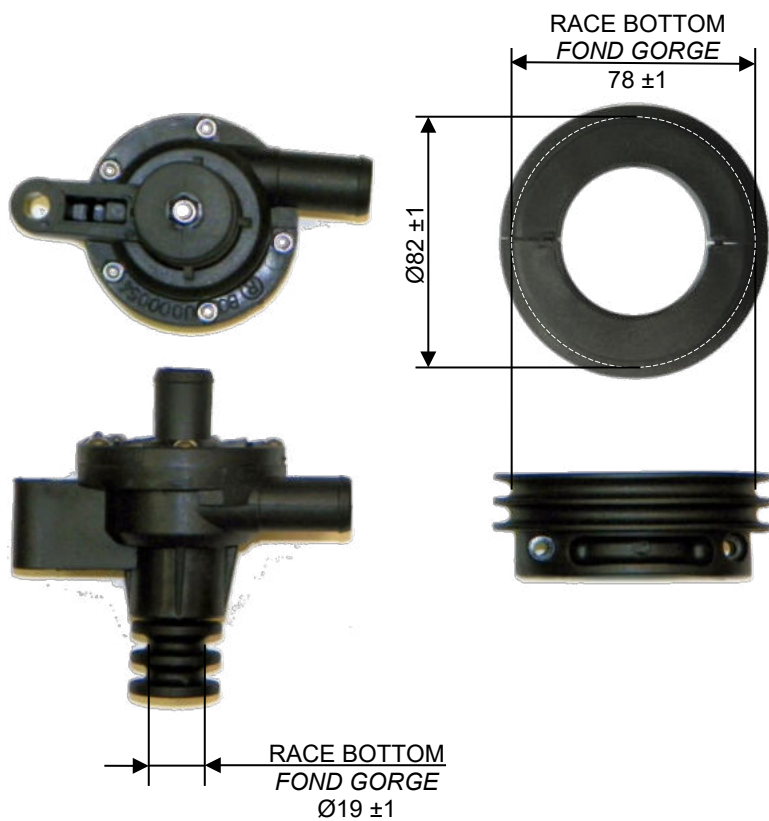

THERMOSTAT



ALTERNATIVE
ALTERNATIF



ALTERNATIVE WATER PUMP & PULLEY
GROUPE POMPE A EAU ET POULIE ALTERNATIF

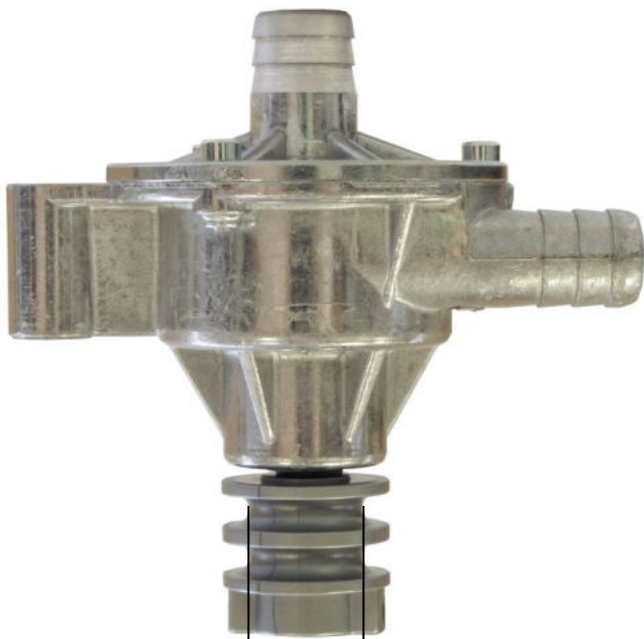

RACE BOTTOM - FOND GORGE
 $\text{Ø}20 \pm 1$

RACE BOTTOM - FOND GORGE $\text{Ø}82.5 \pm 1$

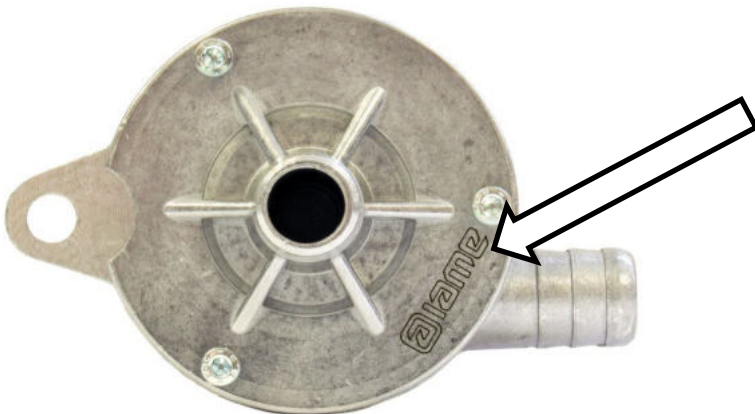

ALTERNATIVE RADIATOR SUPPORT
SUPPORT ALTERNATIF DU RADIATEUR



PISTON IDENTIFICATION MARKING
 MARQUAGE D'IDENTIFICATION PISTON

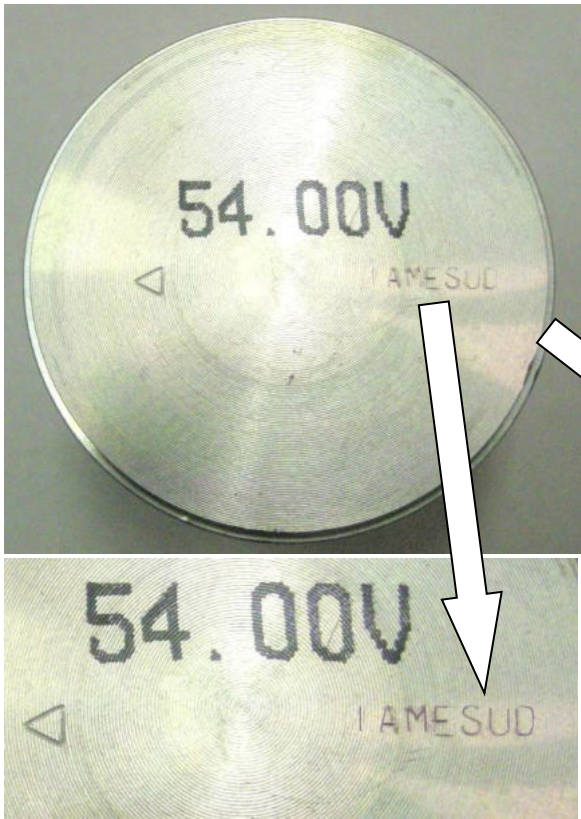
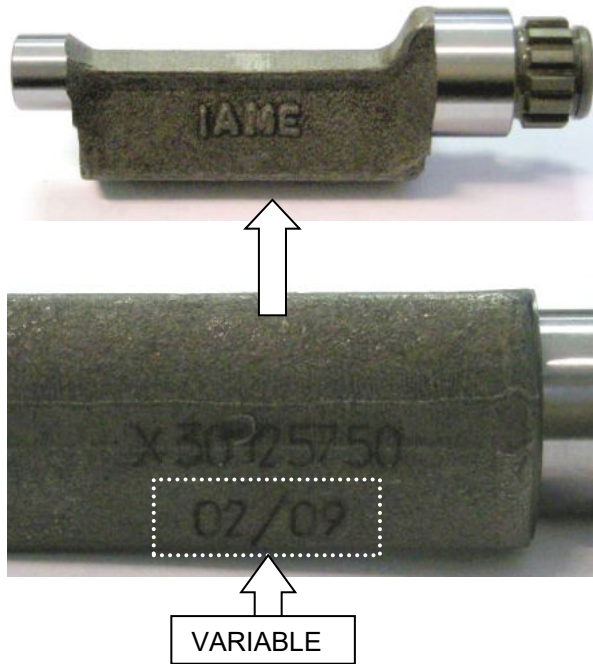
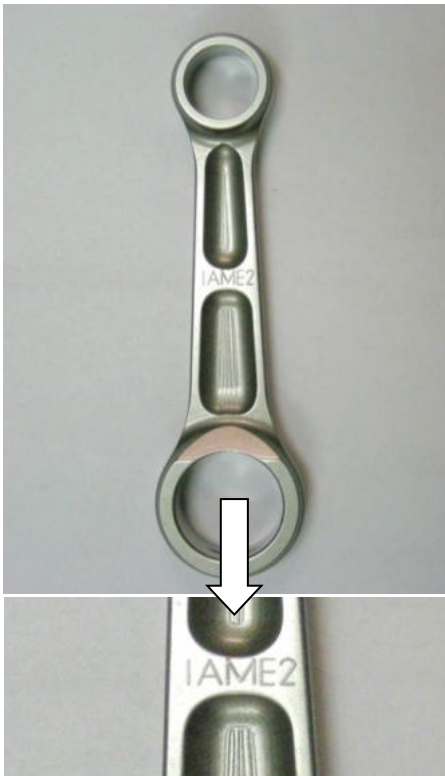
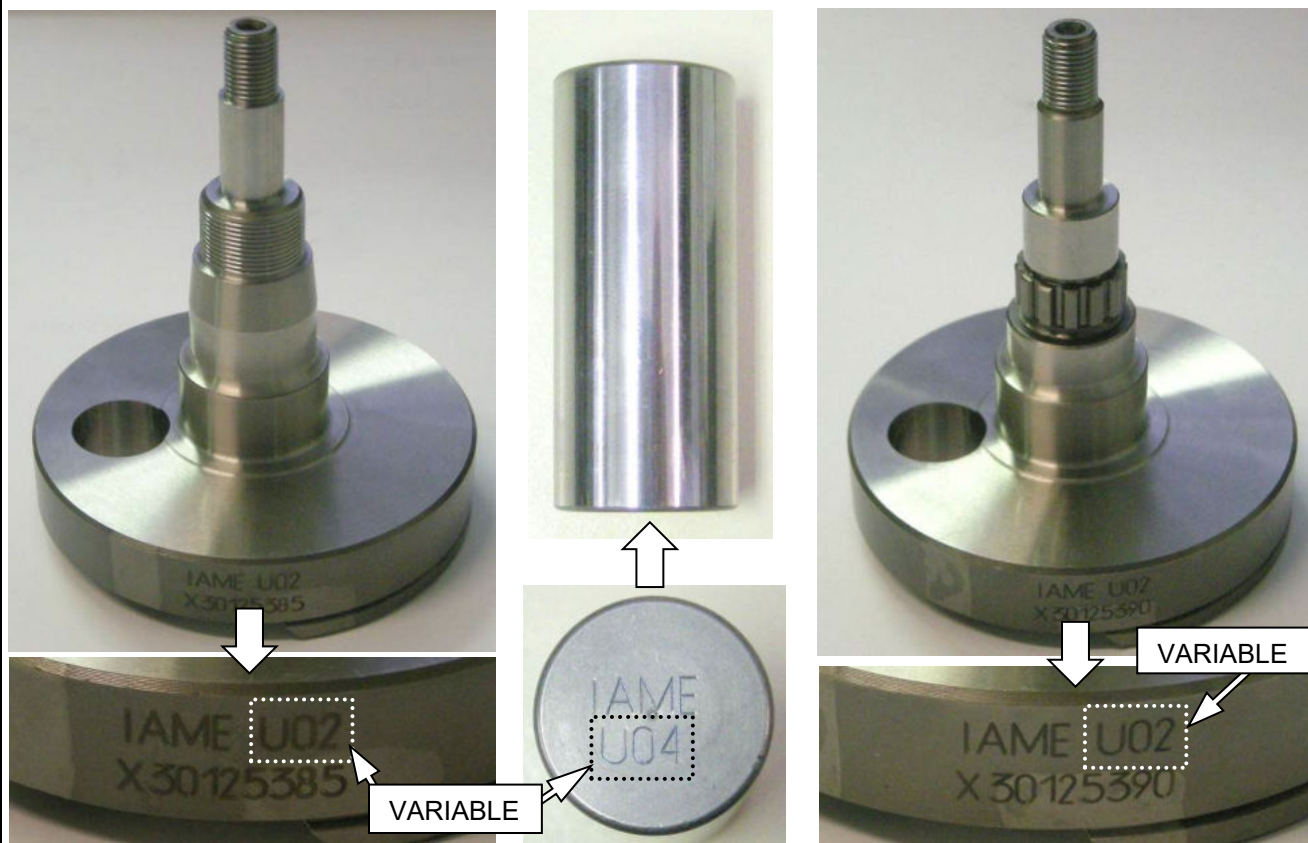

PHOTO IDENTIFICATION CONROD
 PHOTO D'IDENTIFICATION BIELLE

IDENTIFICATION BALANCING SHAFT
 MARKING
 MARQUAGE D'IDENTIFICATION ARBRE
 D'EQUILIBRAGE



**CRANKSHAFT IDENTIFICATION MARKING
MARQUAGE D'IDENTIFICATION DU VILEBREQUIN**



**GEAR COMMAND BALANCING SHAFT
IDENTIFICATION MARKING
MARQUAGE D'IDENTIFICATION
ENGRENAGE ARBRE D'EQUILIBRAGE**

**SPROCKET IDENTIFICATION MARKING
MARQUAGE D'IDENTIFICATION DU PIGNON**

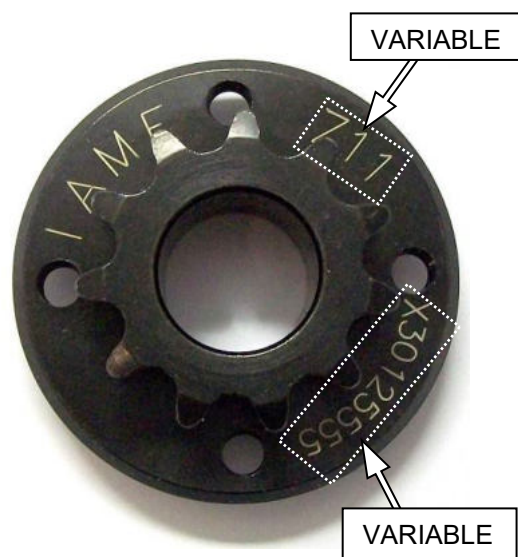
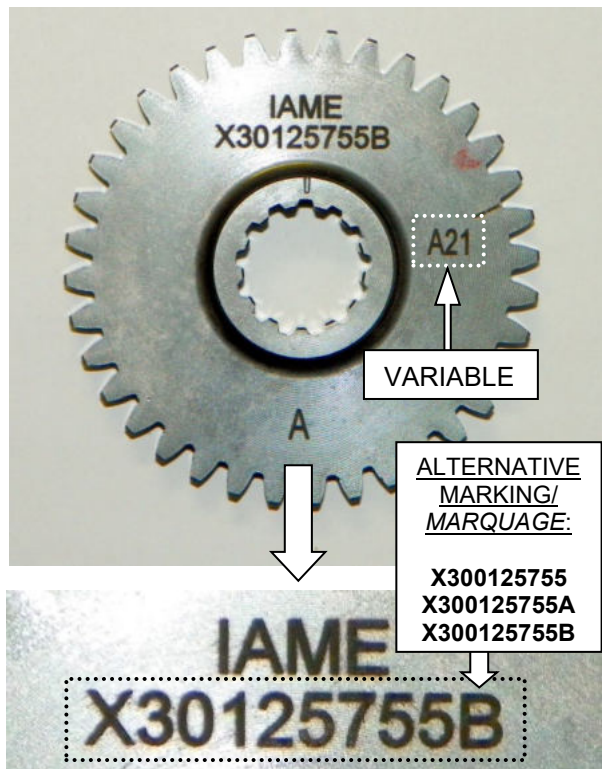

CLUTCH BODY IDENTIFICATION MARKING
 MARQUAGE D'IDENTIFICATION DU CORPS
 DE L'EMBRAYAGE

ALTERNATIVE
 FRICTION
 MATERIAL

MATÉRIAU DE
 FRICTION
 ALTERNATIVE

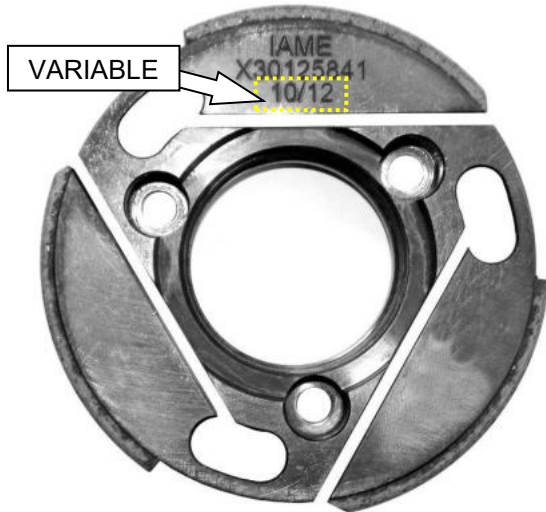

CLUTCH DRUM IDENTIFICATION MARKING
 MARQUAGE D'IDENTIFICATION DE LA
 CALOTTE



STARTER RING IDENTIFICATION MARKING
 MARQUAGE D'IDENTIFICATION DE LA
 COURONNE DE DEMARRAGE

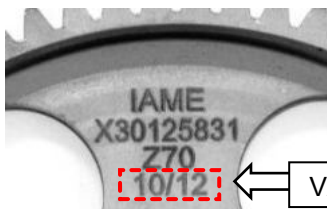

STARTER IDENTIFICATION MARKING
 MARQUAGE D'IDENTIFICATION DU
 DEMARREUR

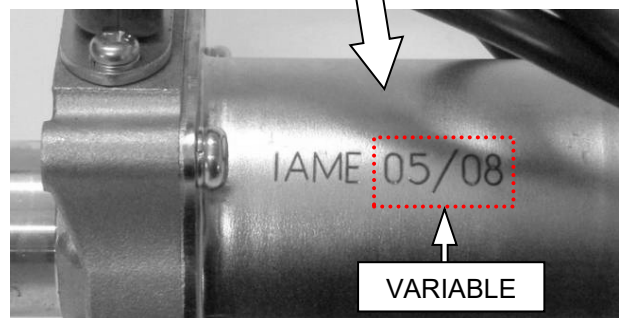

REED GROUP & PETALS IDENTIFICATION MARKING
 MARQUAGE D'IDENTIFICATION DE LA BOÎTE À CLAPETS ET CLAPETS

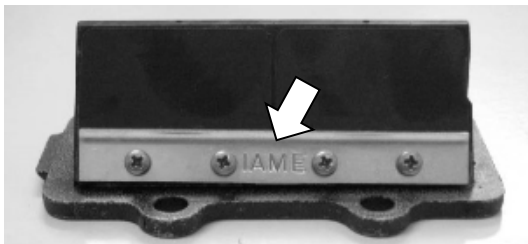
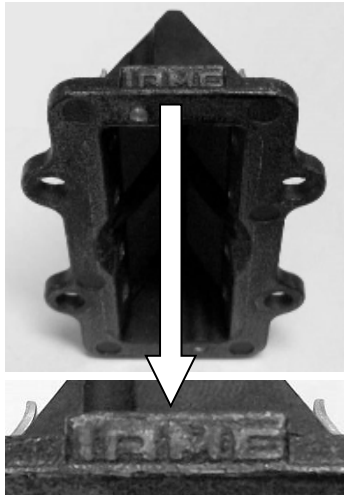

VETRONITE – FIBRE DE VERRE

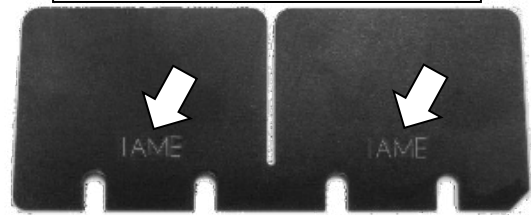

CARBON FIBER / FIBRE CARBONE

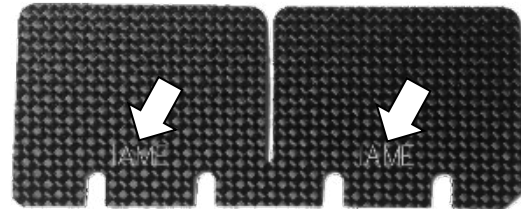

FRONT SIDE
CÔTÉ AVANT

REAR SIDE
CÔTÉ ARRIÈRE

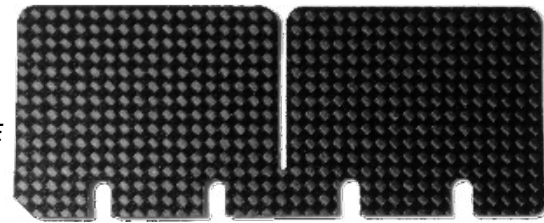
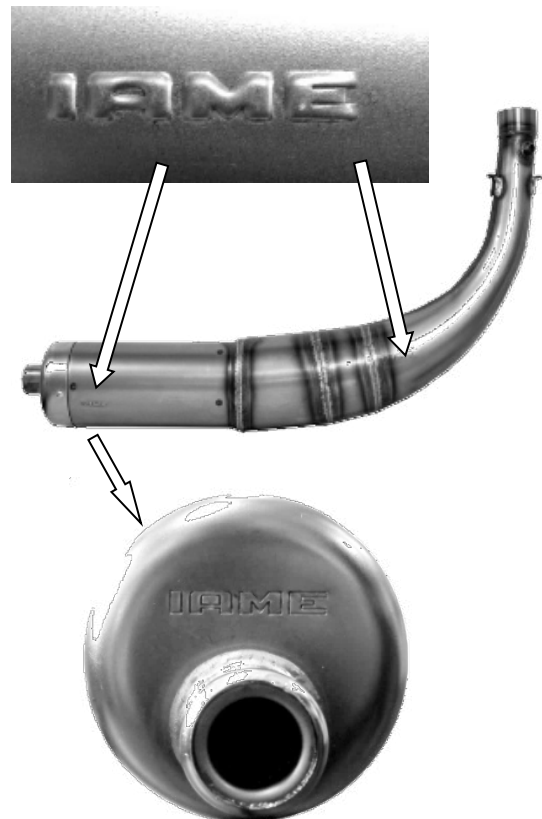
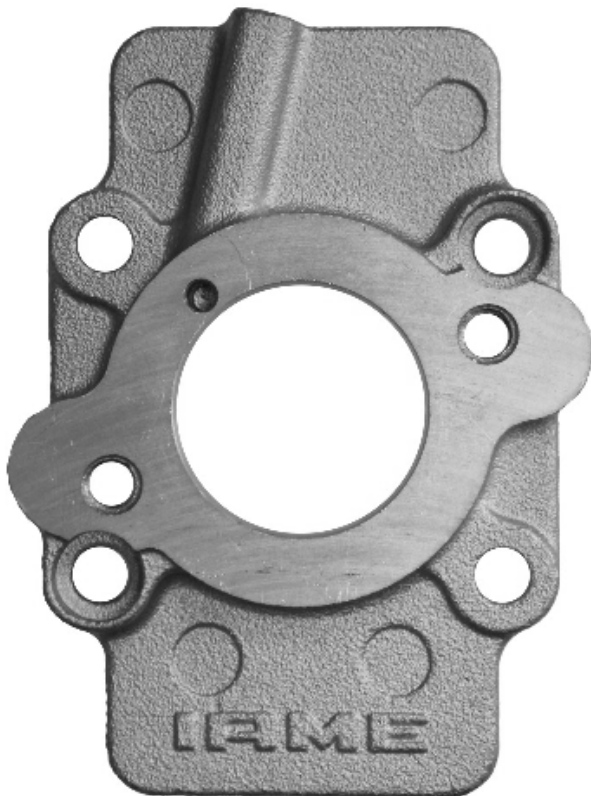
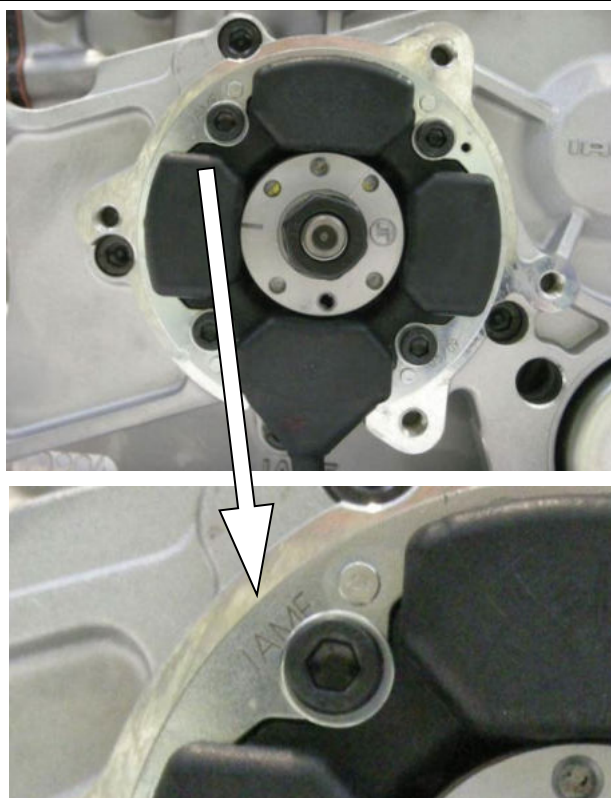

PHOTO IDENTIFICATION CARBURETOR
 INLET CONVEYOR
 MARQUAGE D'IDENTIFICATION DU
 COLLECTEUR D'ADMISSION

EXHAUST SILENCER IDENTIFICATION
 MARKING
 MARQUAGE D'IDENTIFICATION
 ECHAPPEMENT



STATOR IDENTIFICATION MARKING
MARQUAGE D'IDENTIFICATION DU STATOR



CLUTCH COVER AND H.T. COIL IDENTIFICATION MARKING
MARQUAGE DU COUVERCLE D'EMBRAYAGE ET DE LA BOBINE

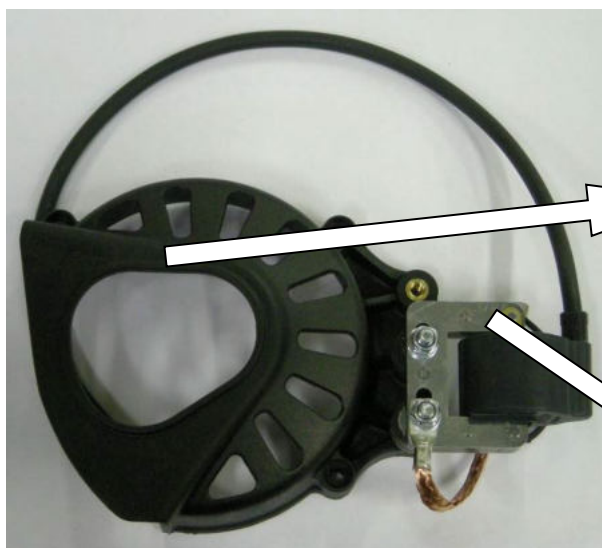

BENDIX COVER IDENTIFICATION MARKING
MARQUAGE D'IDENTIFICATION DU COUVERCLE
DU CONTRE-ARBRE DE DEMARRAGE

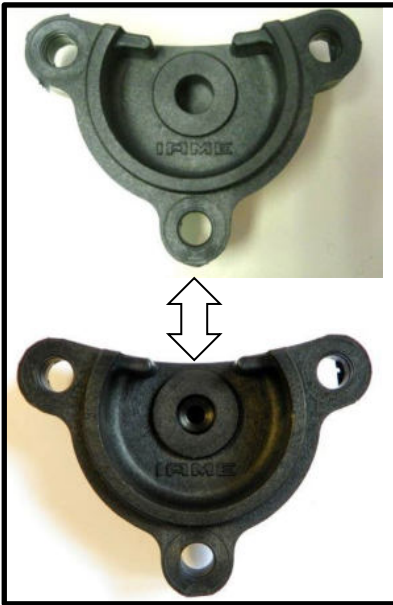

ALTERNATIVE



ALTERNATIVE RADIATOR IDENTIFICATION MARKING
MARQUAGE ALTERNATIF D'IDENTIFICATION DU RADIATEUR

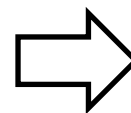
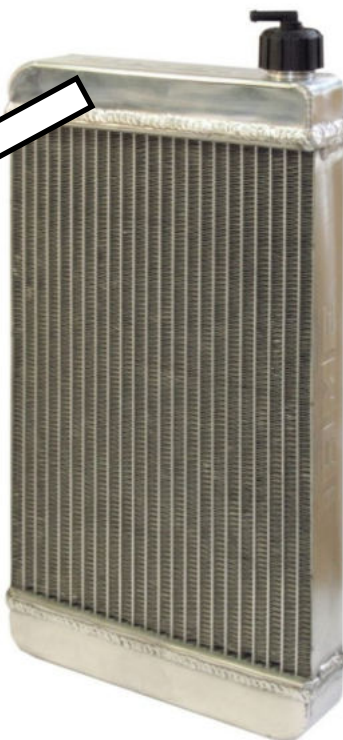
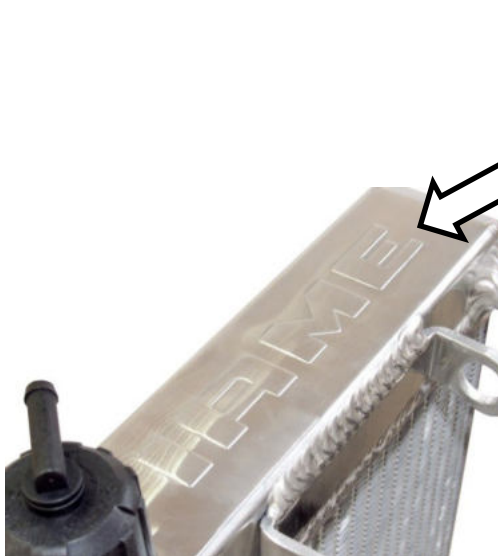

WIRING DIAGRAM (SELETTRA DIGITAL "K" IGNITION 2013)
 SCHÉMA CIRCUIT ELECTRIQUE (ALLUMAGE SELETTRA DIGITAL "K" 2013)

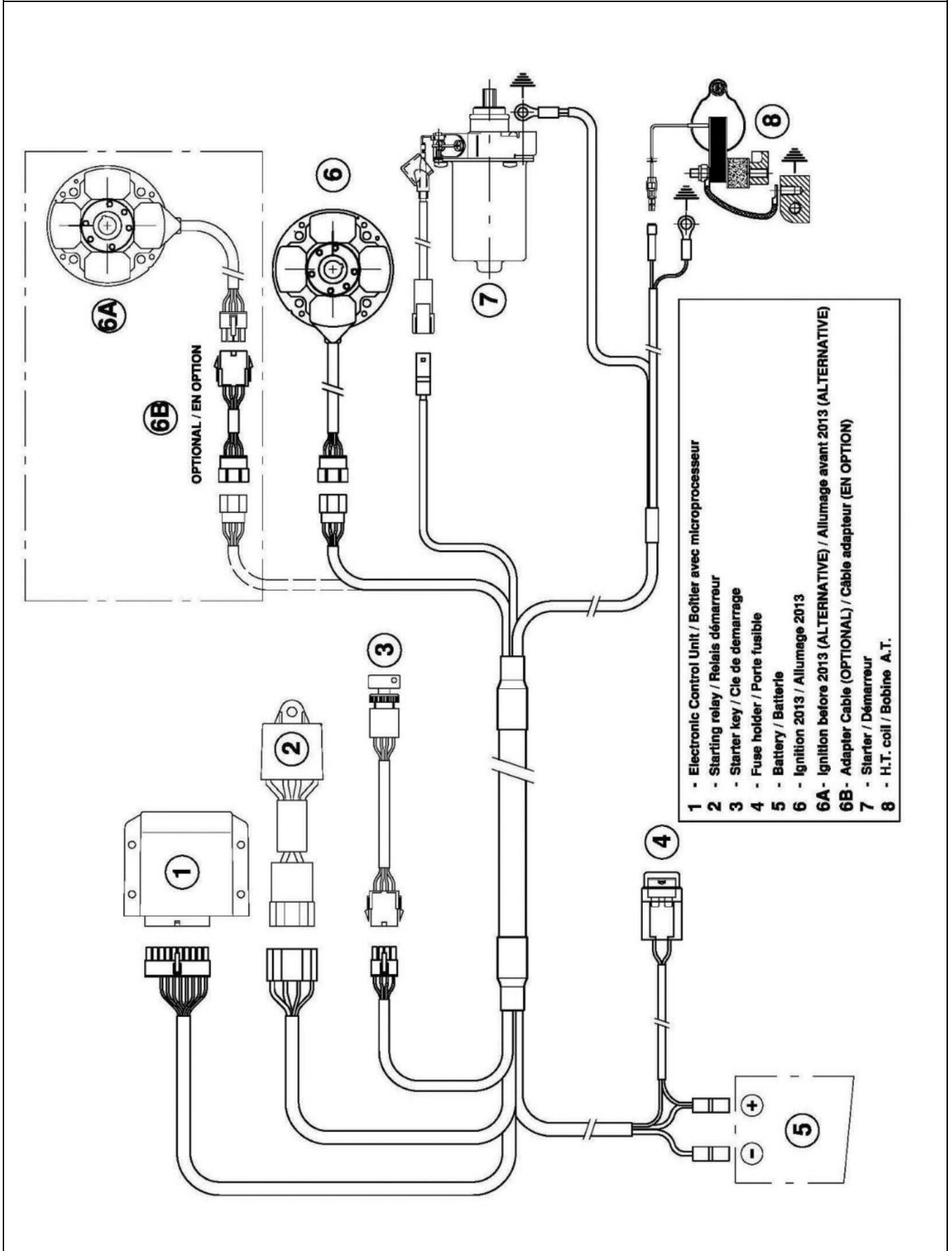

FROM 2014 ON - A PARTIR DE 2014

STICKER APPLICATION AREA - ESPACE POUR L'APPLICATION DES ADHÉSIFS

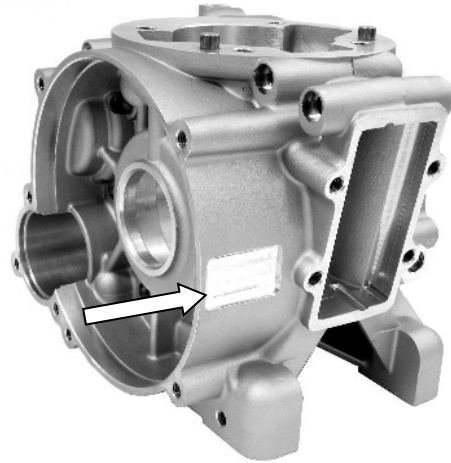
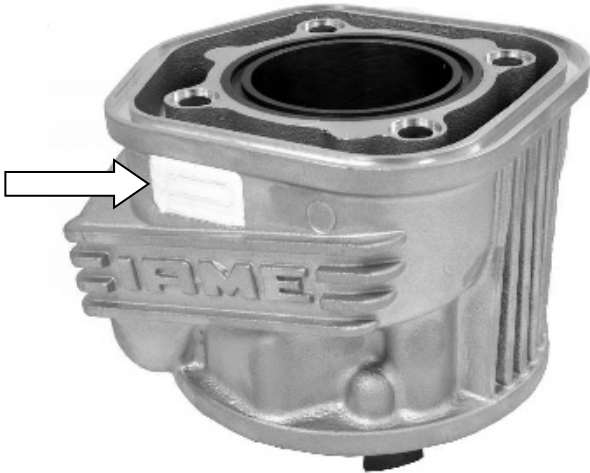

ALTERNATIVE AREA / ZONE ALTERNATIVE

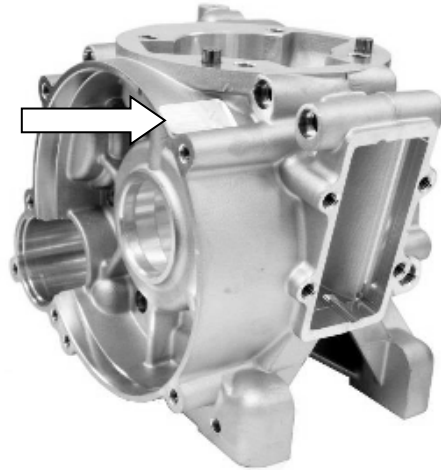

**EXHAUST TEMPERATURE SENSOR
CAPTEUR DE TEMPERATURE D'ÉCHAPPEMENT**

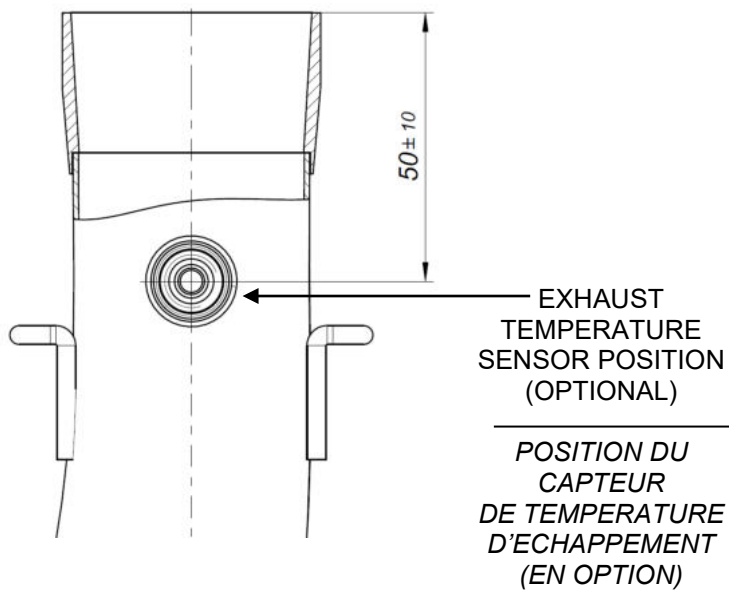

CYLINDER IDENTIFICATION MARKING
MARQUAGE D'IDENTIFICATION DU CYLINDRE

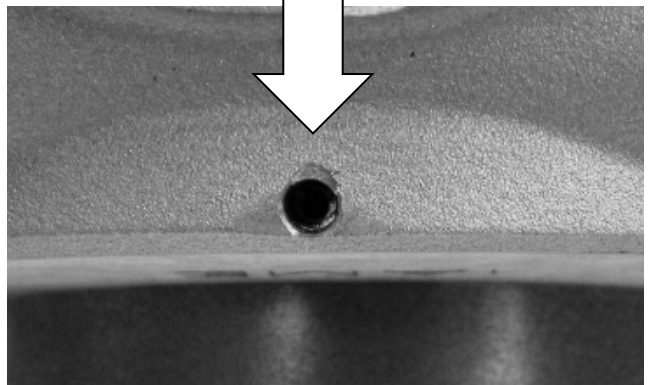
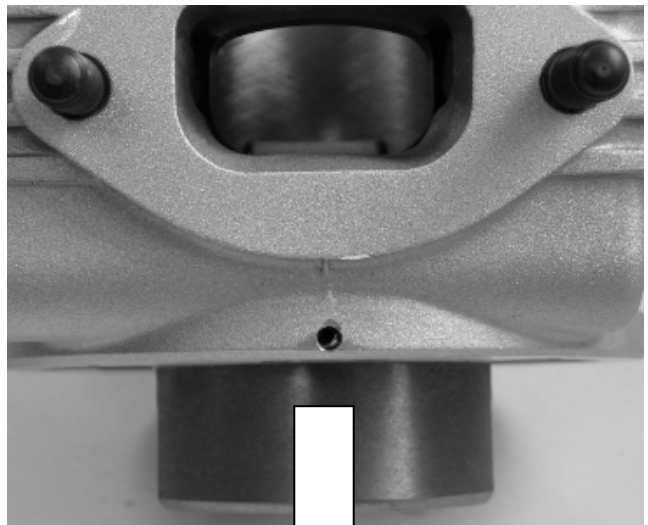
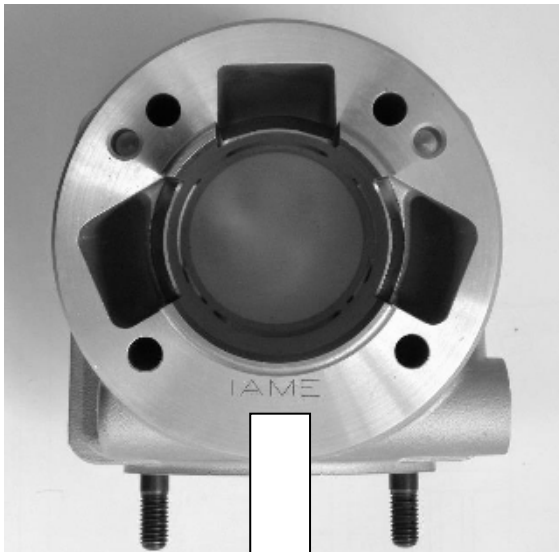
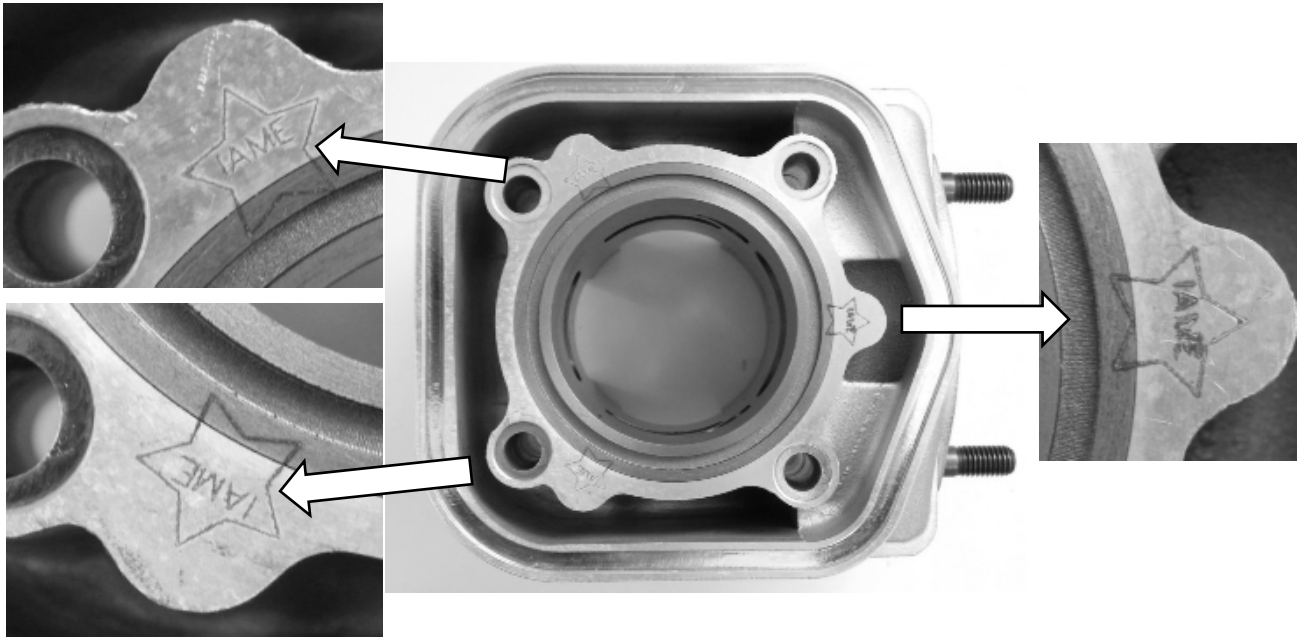

CYLINDER BASE ALTERNATIVE MARKING
MARQUAGE ALTERNATIF DE LA BASE DU CYLINDRE

ALTERNATIVE

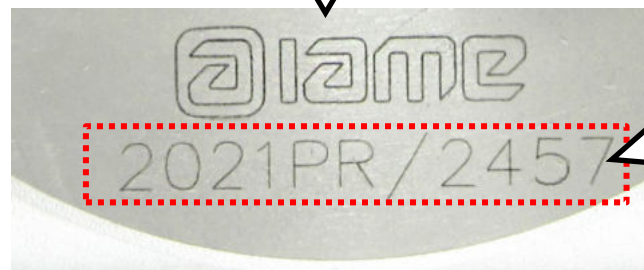
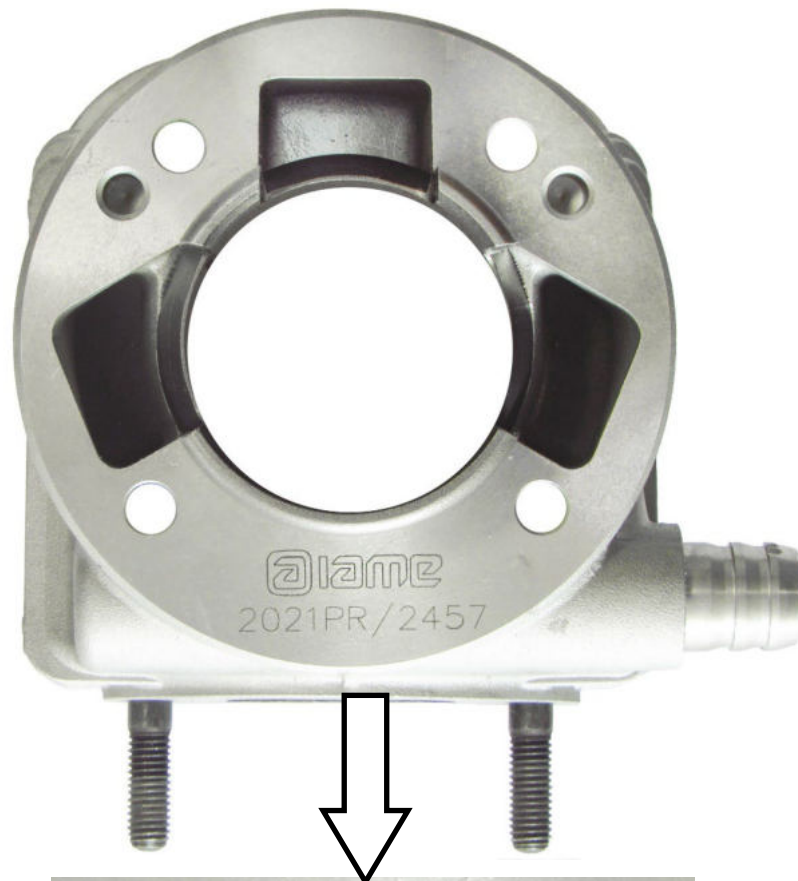

VARIABLE

ALTERNATIVE PUSH BUTTONS – START & STOP
BOUTONS ALTERNATIF “START & STOP” DU DEMARREUR



PHOTO COMPLETE ALTERNATIVE WIRING LOOM
PHOTO DU CABLAGE ELECTRIQUE COMPLET ALTERNATIF



PHOTO OF SELETTRA ALTERNATIVE DIGITAL "S" IGNITION, WITH IAME MARKING
PHOTO DE L'ALLUMAGE SELETTRA DIGITAL "S", AVEC MARQUAGE IAME

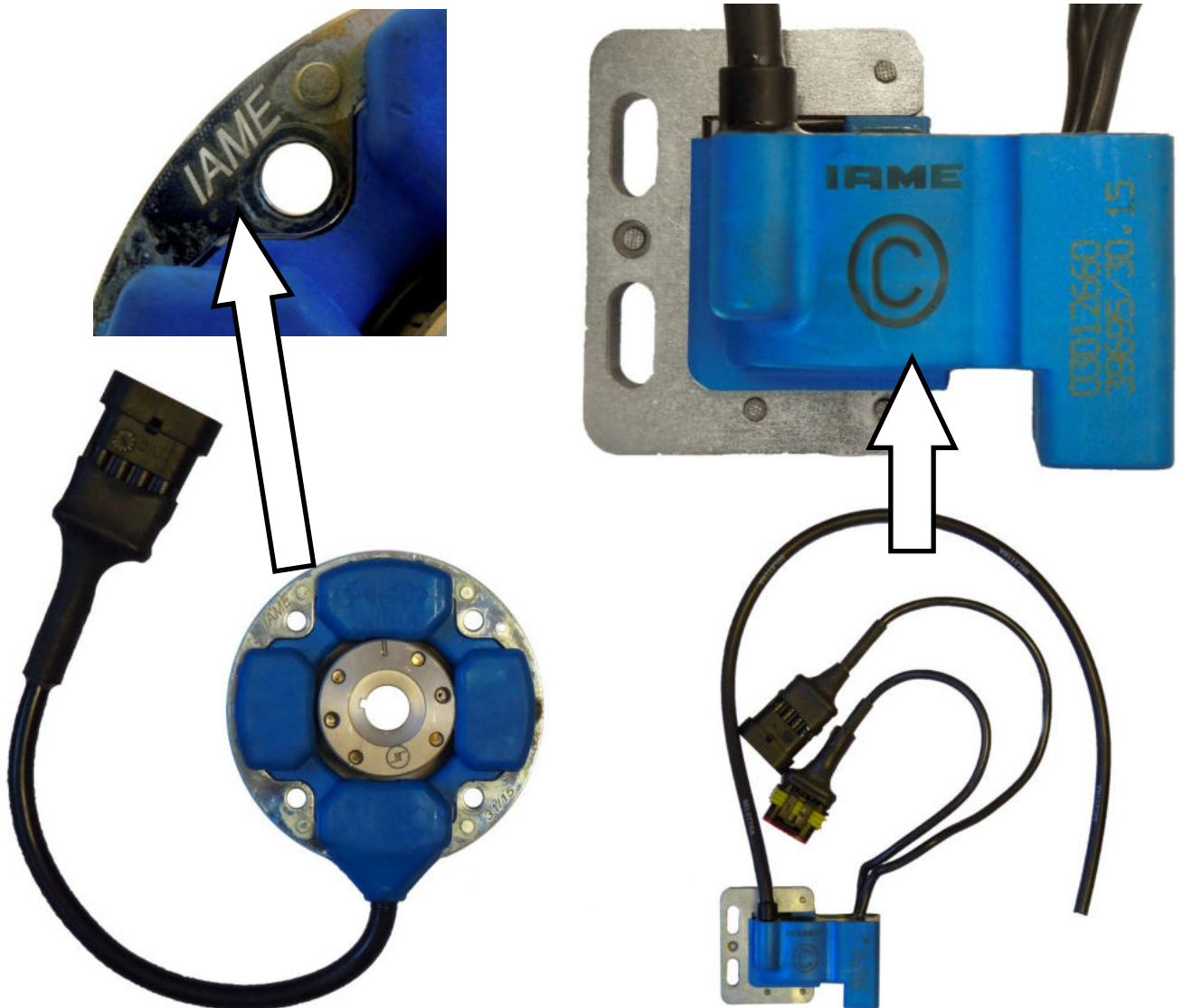

WIRING DIAGRAM (SELETTRA DIGITAL "S" IGNITION)
 SCHÉMA CIRCUIT ELECTRIQUE (ALLUMAGE SELETTRA DIGITAL "S")

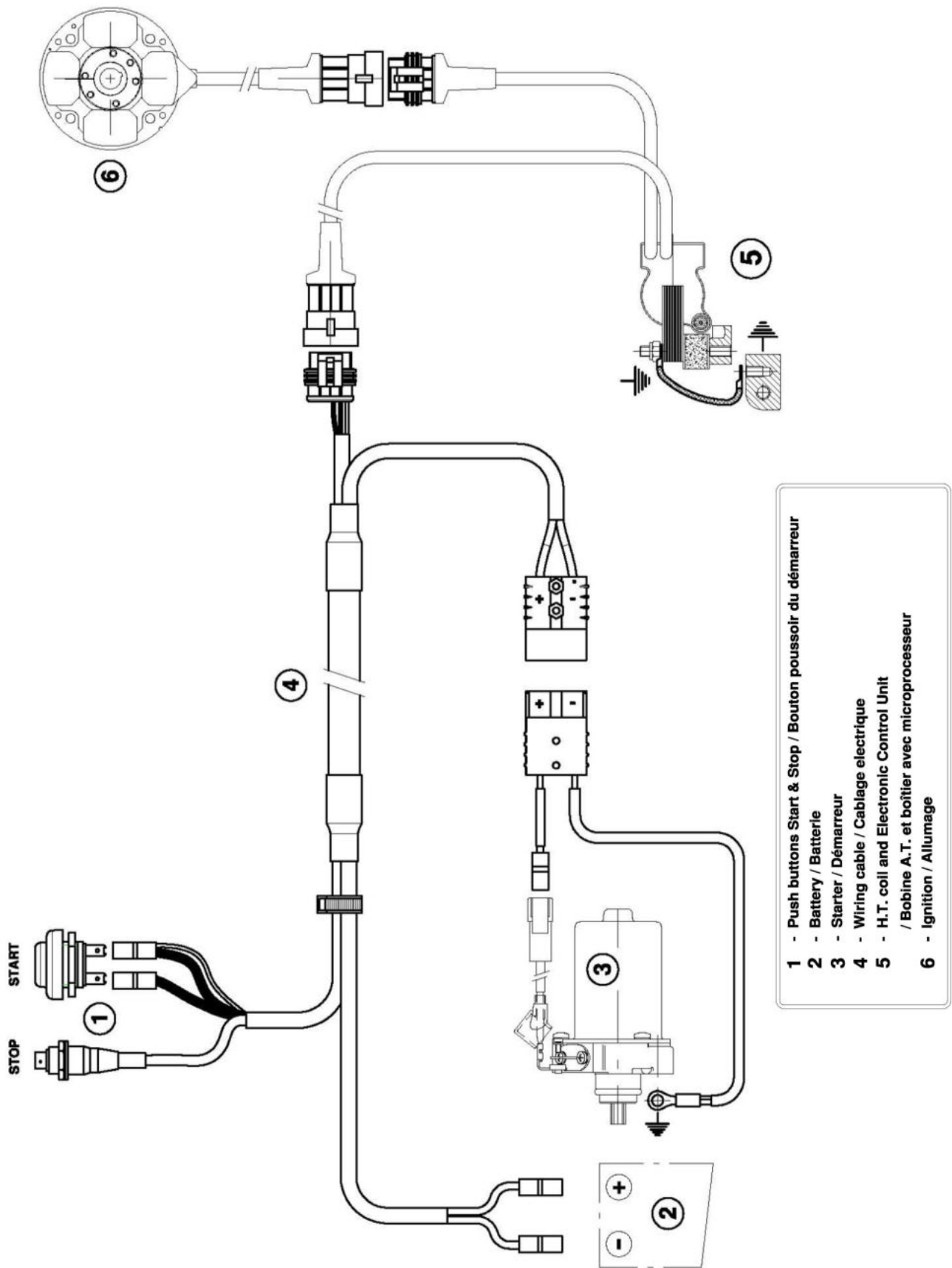

- 1 - Push buttons Start & Stop / Bouton poussoir du démarreur
- 2 - Battery / Batterie
- 3 - Starter / Démarreur
- 4 - Wiring cable / Cablage électrique
- 5 - H.T. coil and Electronic Control Unit / Bobine A.T. et boîtier avec microprocesseur
- 6 - Ignition / Allumage

ALTERNATIVE WIRING LOOM
CABLAGE ELECTRIQUE COMPLET ALTERNATIF



ALTERNATIVE WIRING LOOM DIAGRAM
SCHÉMA CIRCUIT ELECTRIQUE ALTERNATIF

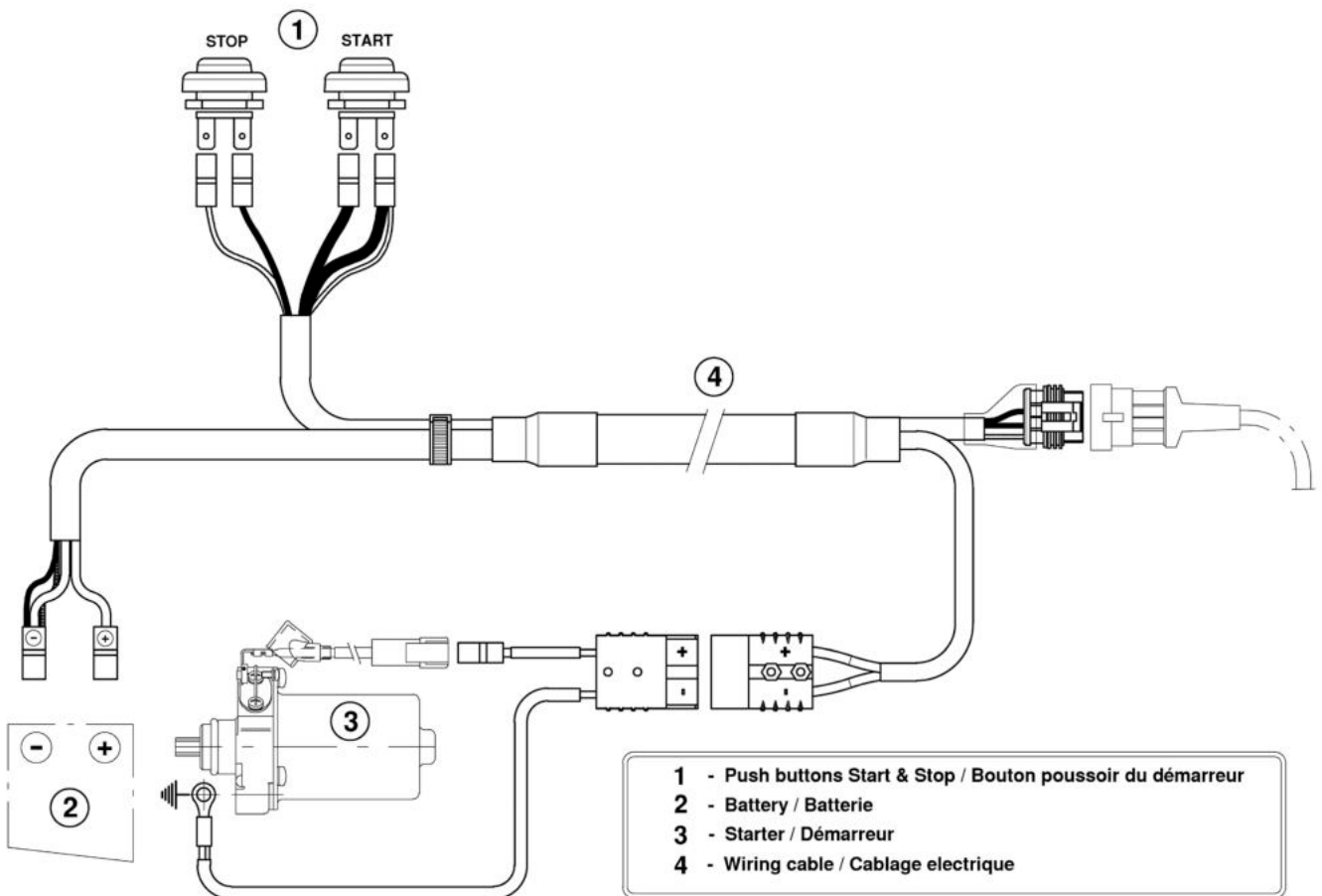

ALTERNATIVE WIRING LOOM
CABLAGE ELECTRIQUE COMPLET ALTERNATIF



ALTERNATIVE WIRING LOOM DIAGRAM
SCHÉMA CIRCUIT ELECTRIQUE ALTERNATIF

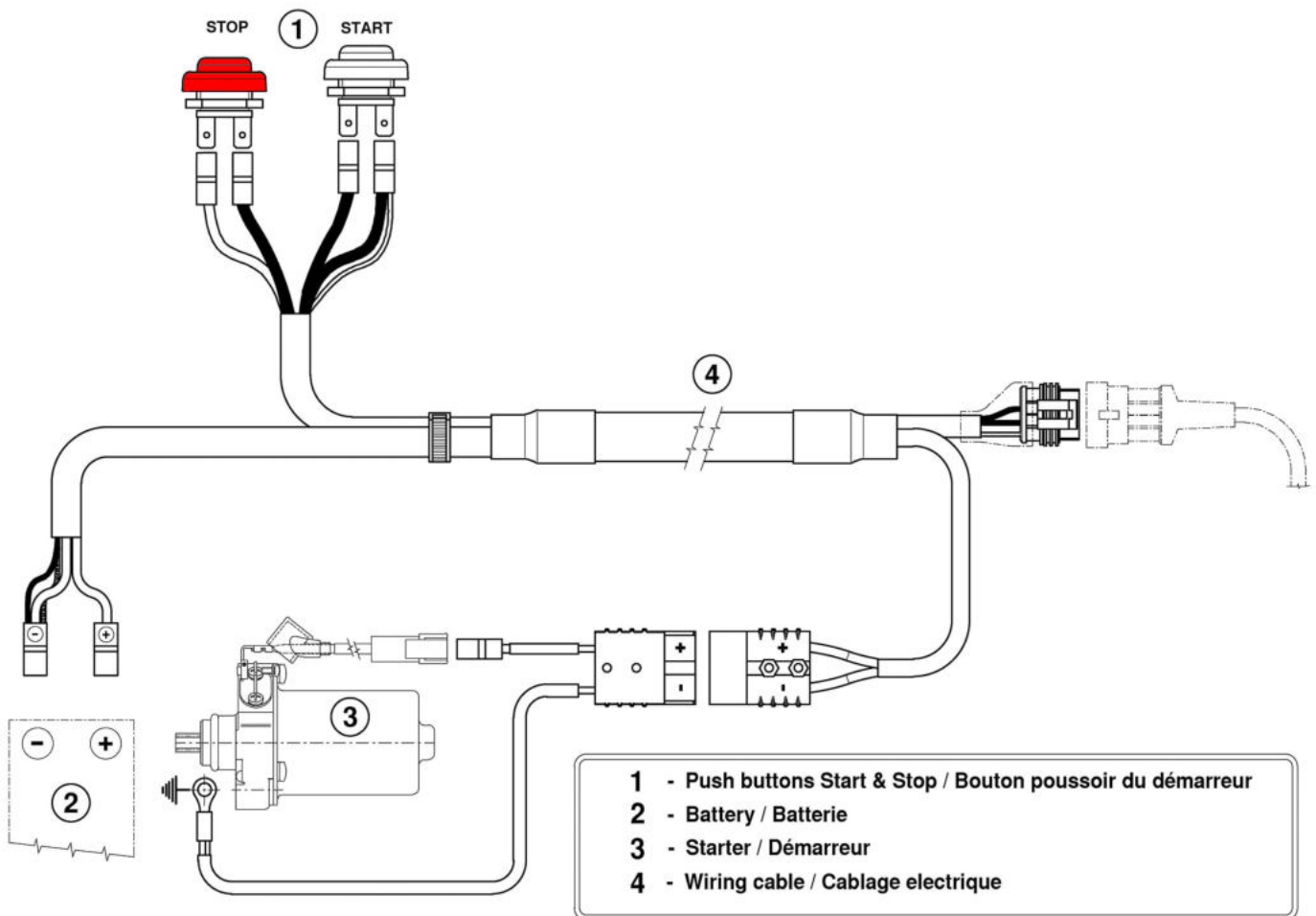
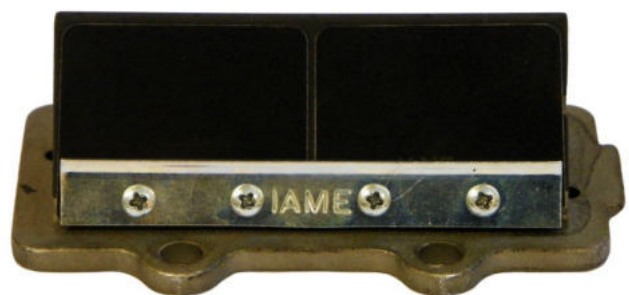
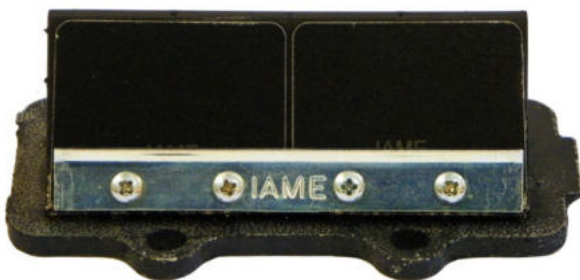
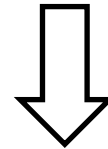
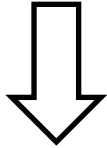

PHOTO IDENTIFICATION REED GROUP
PHOTO IDENTIFICATION BOÎTE À CLAPETS

ACTUAL VERSION
VERSION COURANTE

ALTERNATIVE VERSION
VERSION ALTERNATIVE



ACTUAL PISTON
PISTON COURANT

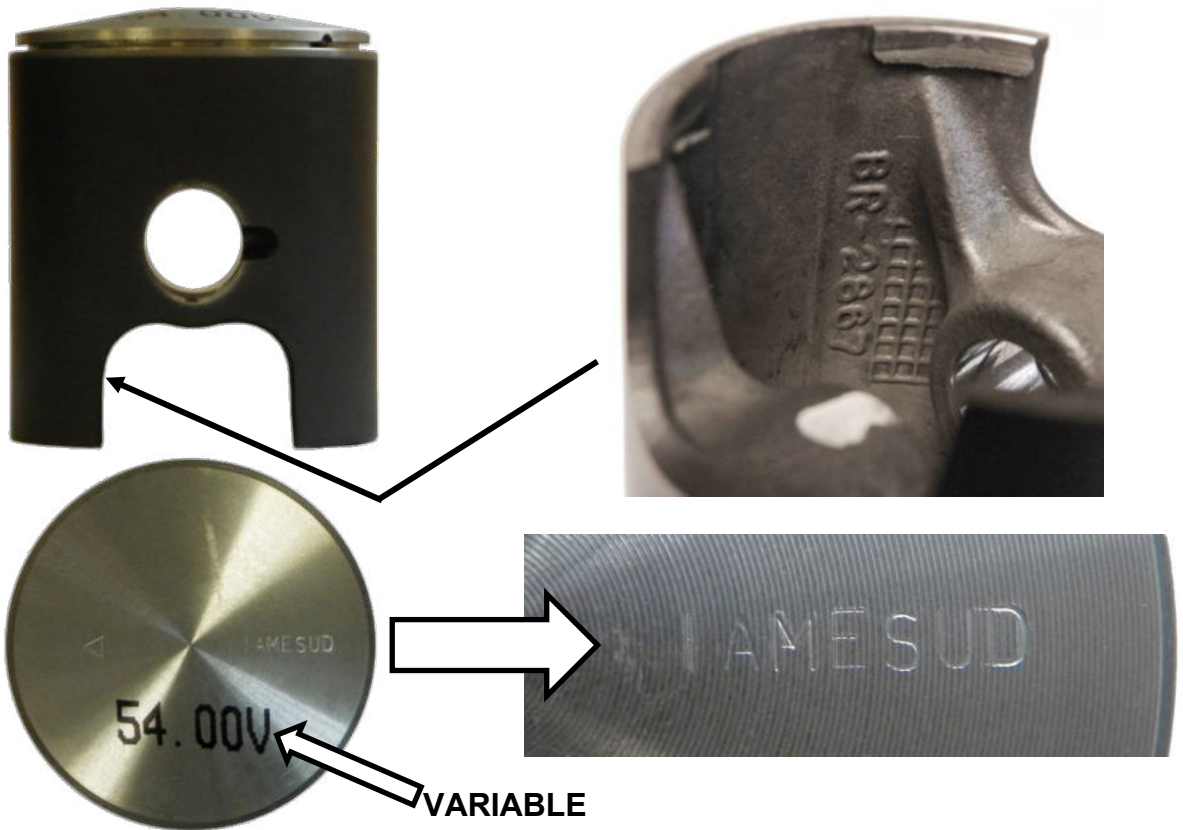

ALTERNATIVE PISTON
PISTON ALTERNATIF

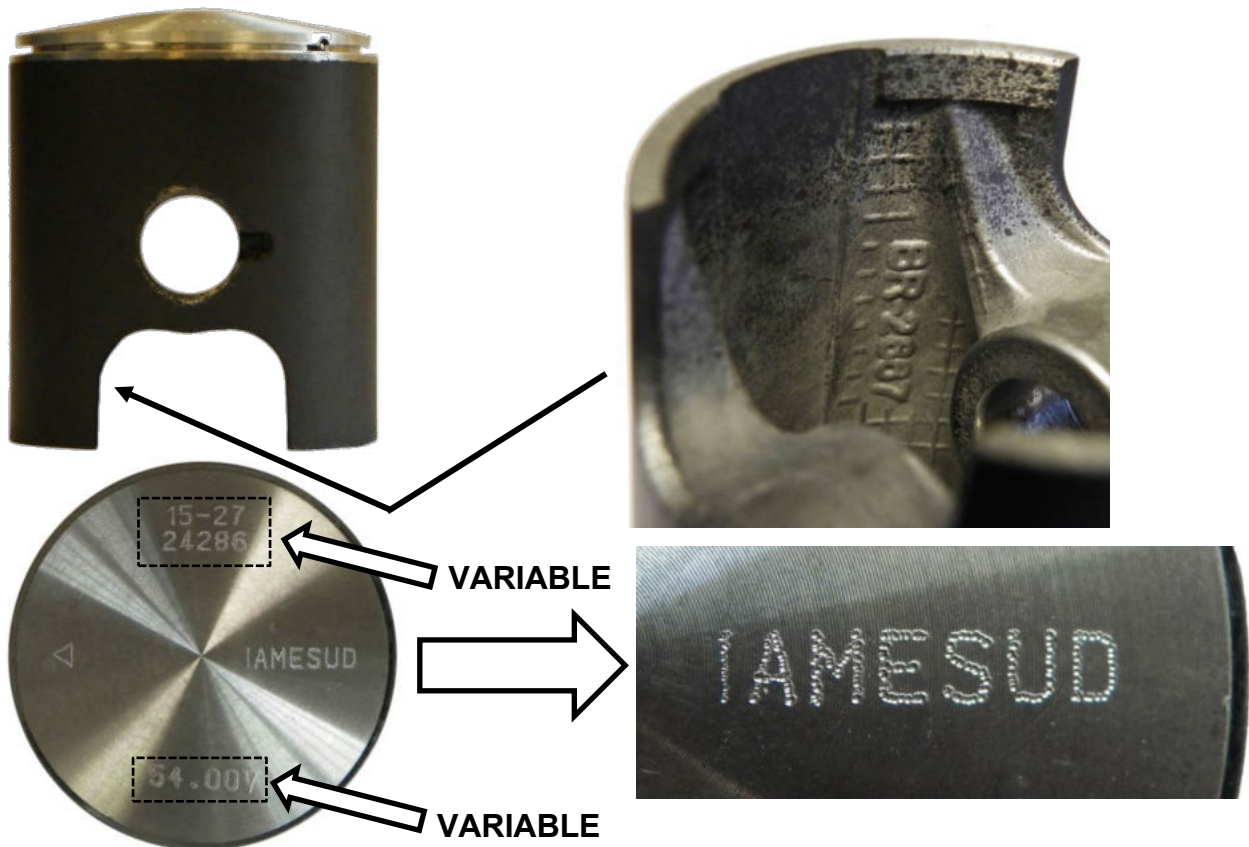

ALTERNATIVE CONROD
BIELLE ALTERNATIVE

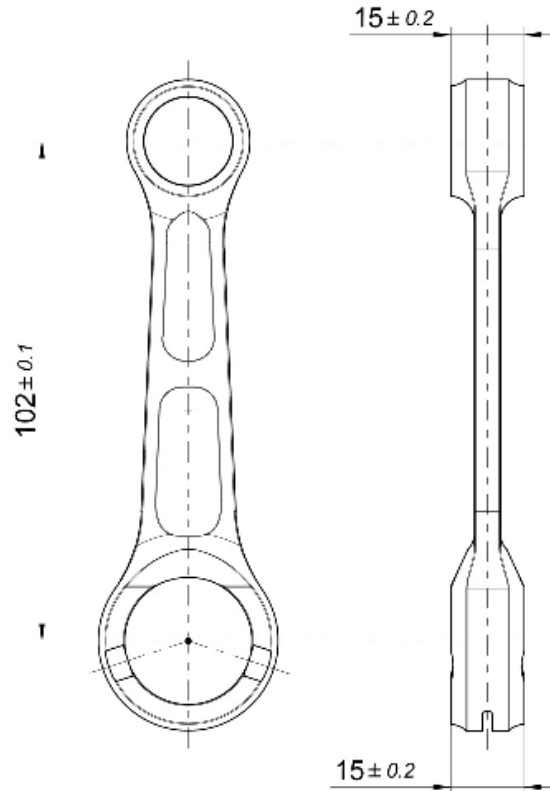
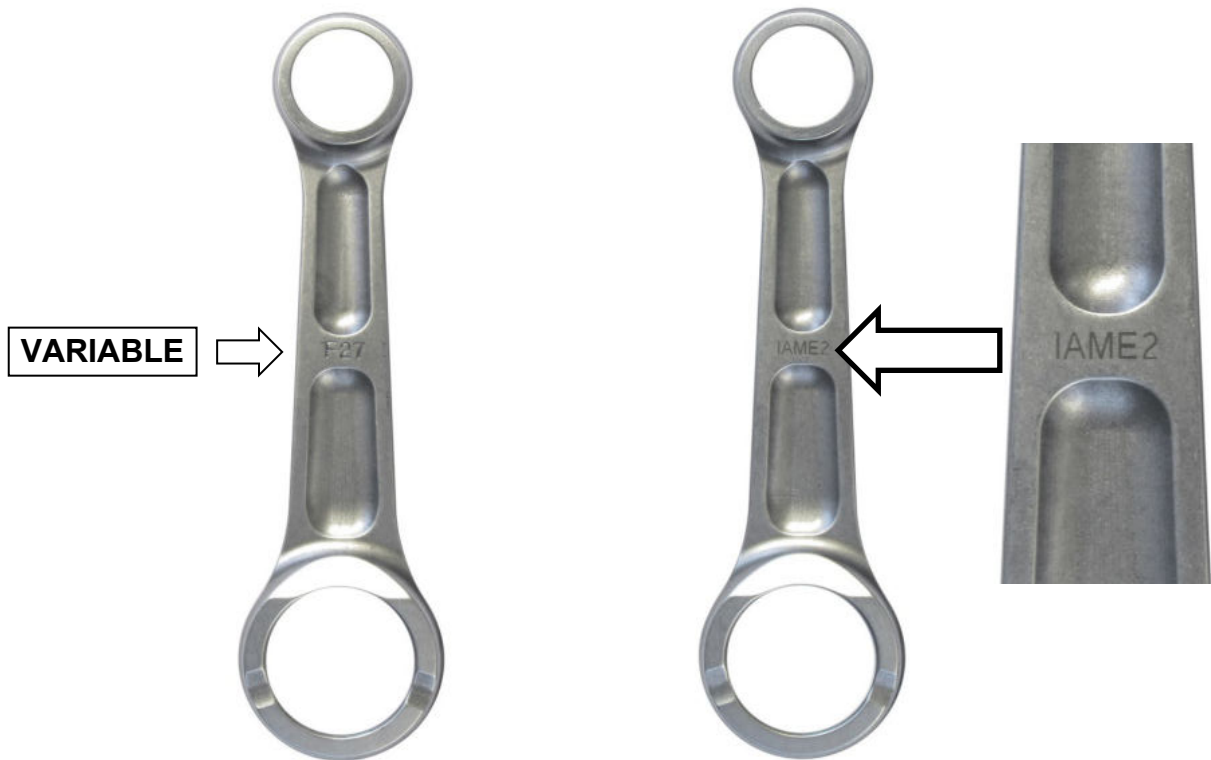

PHOTO OF THE CONROD BOTH SIDE – ALTERNATIVE
PHOTO DES DEUX COTES DE LA BIELLE - ALTERNATIVE



**BOTH TYPES OF CONROD CAN BE USED WITH BOTH TYPES OF WASHERS (IN COUPLE)
LES DEUX TYPES DE BIELLE PEUVENT ÊTRE UTILISÉS AVEC LES DEUX TYPES DE
RONDELLES (EN COUPLE)**

PHOTO IDENTIFICATION OF SMALL END CONROD BEARING – TYPES ALTERNATIVE
PHOTO D'IDENTIFICATION DU ROULEMENT PIED DE BIELLE – TYPES ALTERNATIFS

TYPE 1



TYPE 2



PHOTO IDENTIFICATION OF CONROD WASHER – TYPES ALTERNATIVE
PHOTO D'IDENTIFICATION RONDELLE DE BIELLE – TYPES ALTERNATIVES









TYPE 1



TYPE 2

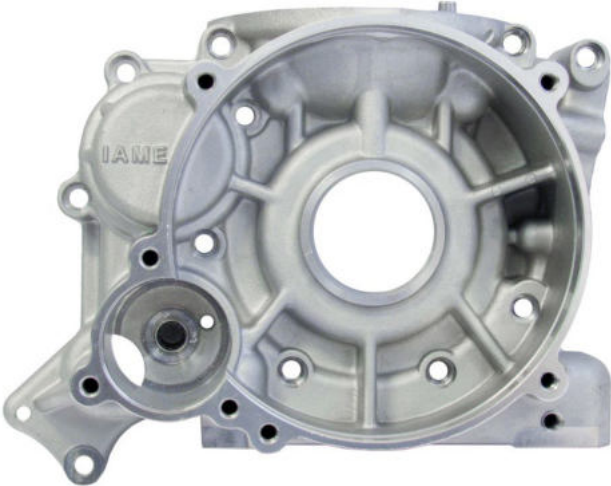

PARTS WITH ALTERNATIVE NEW LOGO "IAME"
COMPOSANTS AVEC UN NOUVEAU LOGO ALTERNATIF «IAME»

<p align="center">CYLINDER HEAD <i>CULASSE</i></p>	<p align="center">CYLINDER <i>CYLINDRE</i></p>
 <p align="center">NEW / NOUVEAU LOGO</p> 	 <p align="center">NEW / NOUVEAU LOGO</p> 
<p align="center">SEMICARTER TRANSMISSION SIDE <i>DEMI-CARTER CÔTÉ PIGNON</i></p>	<p align="center">SEMICARTER IGNITION SIDE <i>DEMI-CARTER CÔTÉ ALLUMAGE</i></p>
 <p align="center">NEW / NOUVEAU LOGO</p> 	 <p align="center">NEW / NOUVEAU LOGO</p> 

PARTS WITH ALTERNATIVE NEW LOGO "IAME"
COMPOSANTS AVEC UN NOUVEAU LOGO ALTERNATIF «IAME»

IGNITION COVER
COUVERCLE DE L'ALLUMAGE

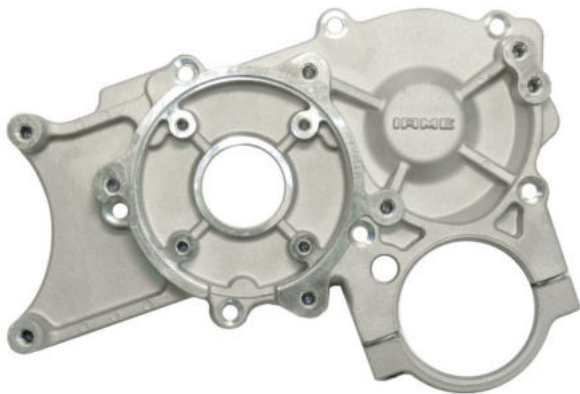

NEW / NOUVEAU LOGO

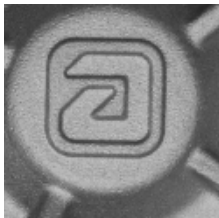

CLUTCH COVER
COUVERCLE D'EMBRAYAGE



NEW / NOUVEAU LOGO



REED GROUP
GROUPE CLAPETS

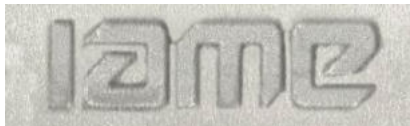

NEW / NOUVEAU LOGO





CARBURETTOR INLET CONVEYOR
CONVOYEUR D'ADMISSION



NEW / NOUVEAU LOGO

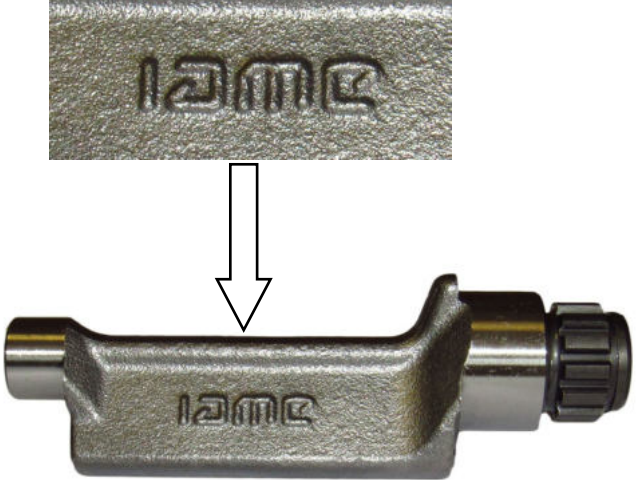

PARTS WITH ALTERNATIVE NEW LOGO "IAME"
COMPOSANTS AVEC UN NOUVEAU LOGO ALTERNATIF «IAME»

<p align="center">RADIATOR RADIATEUR</p>	<p align="center">EXHAUST SILENCER ECHAPPEMENT</p>
<p align="center">NEW / NOUVEAU LOGO</p>  <p>The image shows a rectangular radiator with a black top cap and a black bottom base. To its right is a vertical rectangular plate with the 'IAME' logo embossed in a stylized, bold font.</p>	<p align="center">NEW / NOUVEAU LOGO</p>  <p>The image shows a curved metal exhaust silencer. Above it is a rectangular plate with the 'IAME' logo embossed. Below the silencer is a circular metal component with the 'IAME' logo embossed on its top surface. Below that is another rectangular plate with the 'IAME' logo embossed.</p>
<p align="center">BALANCING SHAFT ARBRE D'EQUILIBRAGE</p>	
<p align="center">NEW / NOUVEAU LOGO</p>  <p>The image shows a balancing shaft component. Above it is a rectangular plate with the 'IAME' logo embossed. A white arrow points from the logo on the plate down to the shaft, which has the 'IAME' logo embossed on its side.</p>	

THE OTHERS COMPONENTS OF ENGINE THAT ARE MARKED (LASER OR PUNCHING) UNTIL TODAY WITH LOGO OR WRITTEN "IAME"

LES AUTRES COMPOSANTS DU MOTEUR AVEC COMME MARQUAGE (LASER OU POINÇONNEUSE) L'ANCIEN LOGO OU ÉCRIT «IAME»

I A M E

or

IAME

NOW COULD BE MARKED WITH NEW LOGO "IAME"

POURRAIENT MAINTENANT ETRE MARQUES AVEC LE NOUVEAU LOGO "IAME"

ia me

or

ⓐ i a m e

or

ⓐ

CHECKING THE SHAPE OF THE COMBUSTION CHAMBER
CONTRÔLE DE LA FORME DE LA CHAMBRE DE COMBUSTION

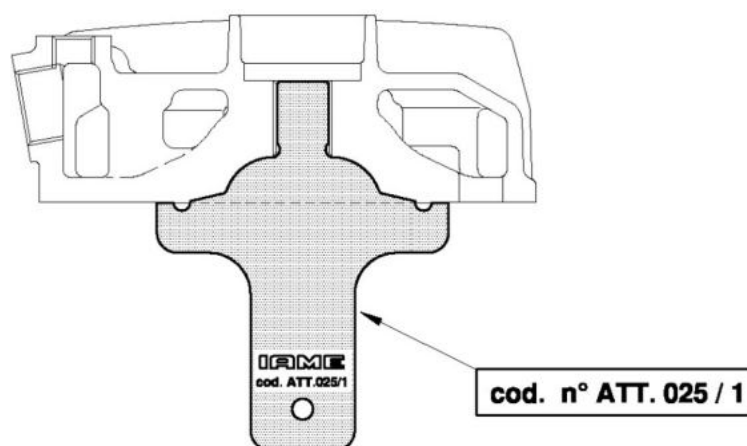

CONTROL OF THE PISTON DOME
CONTRÔLE DU DÔME DE PISTON

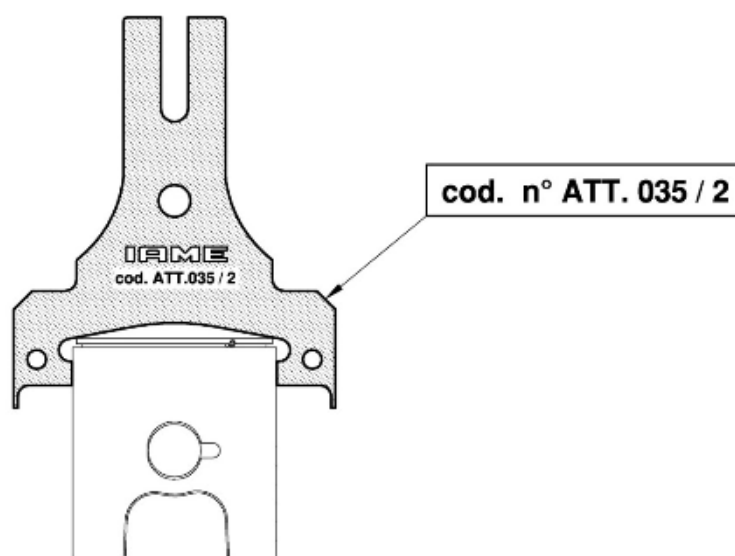

CONTROL OF THE VOLUME OF THE COMBUSTION CHAMBER
CONTRÔLE DU VOLUME DE LA CHAMBRE DE COMBUSTION

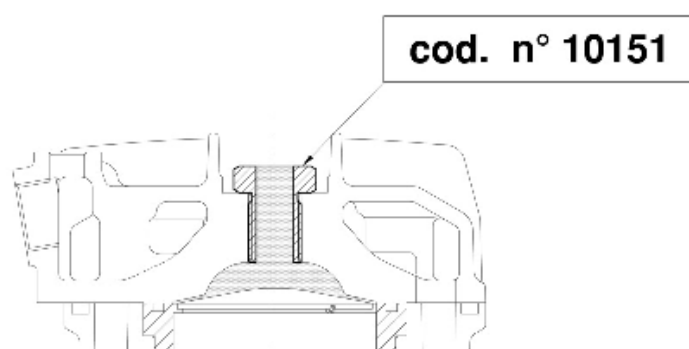

CYLINDER CHECK - CONTRÔLE DU CYLINDRE
CHECKING OF EXHAUST DUCT AND LATERAL TRANSFERS
CONTRÔLE DE LA LUMIÈRE D'ÉCHAPPEMENT ET DES TRANSFERTS LATÉRAUX

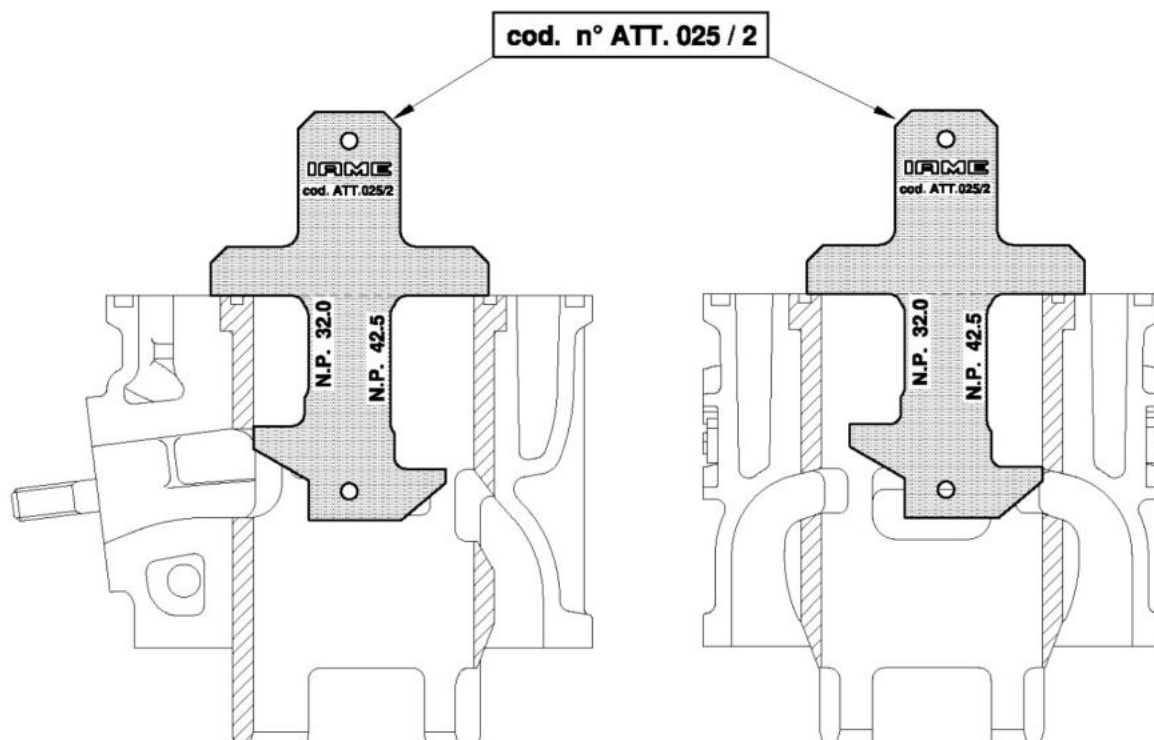

CYLINDER LINER DUCTS AND TRANSFERS CHECKING TOOL
OUTIL DE VÉRIFICATION DES LUMIÈRES DE LA CHEMISE DU CYLINDRE

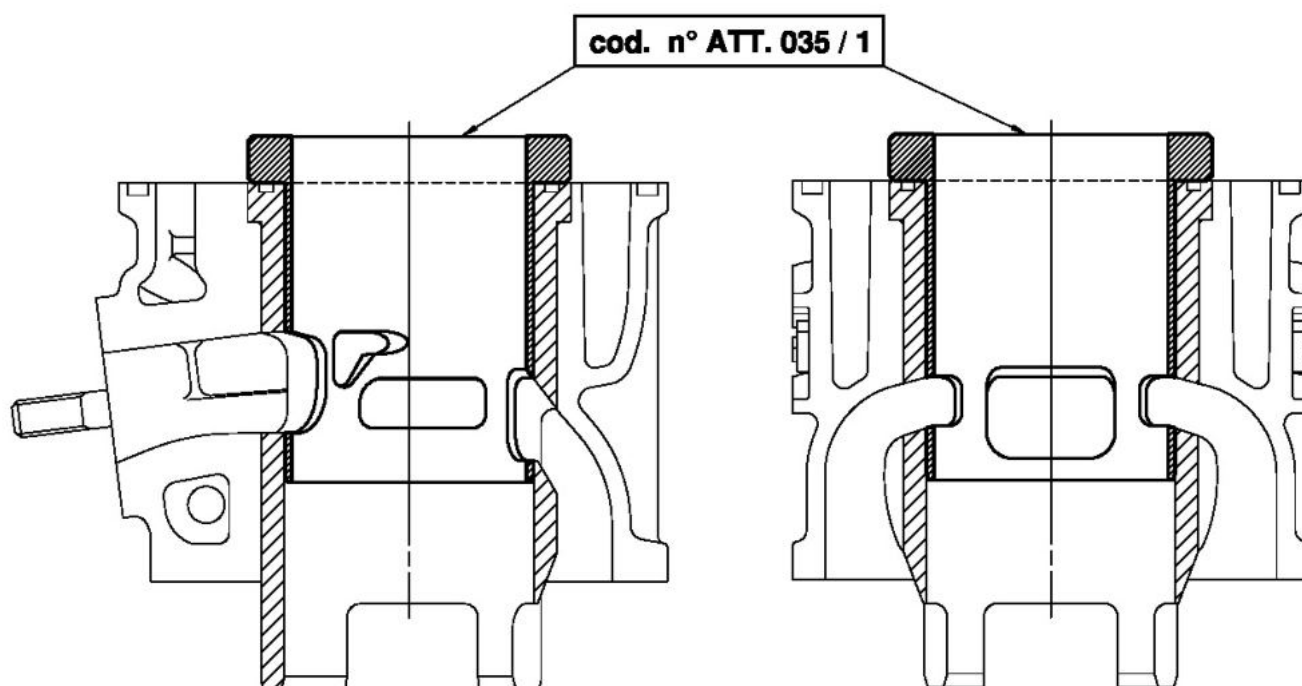

CLUTCH DRUM CHECKING TOOL
CONTRÔLE DE LA CLOCHE D'EMBRAYAGE

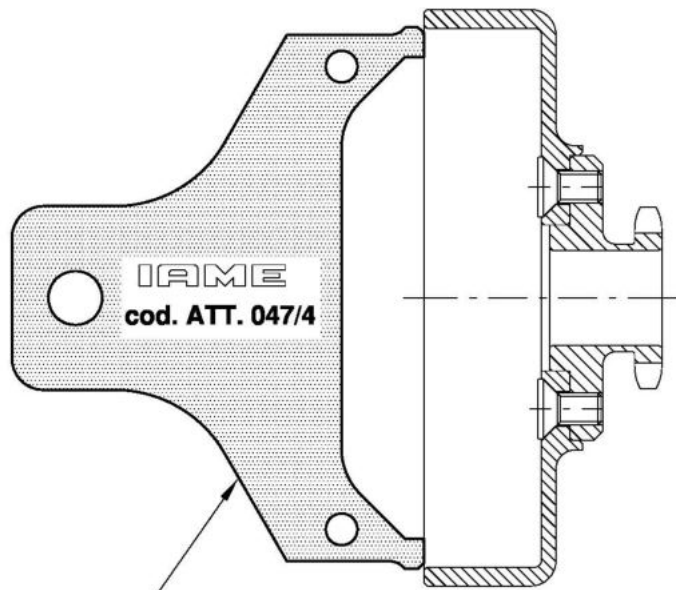

cod. n° ATT. 047 / 4

CRANKCASE CHECKING TOOLS - CONTRÔLE DU CARTER

CHECKING THE INTERAXLE OF THE CILYNDER PINS
CONTRÔLE DE L'ENTRAXE DES PIONS DE CENTRAGE DU CYLINDRE

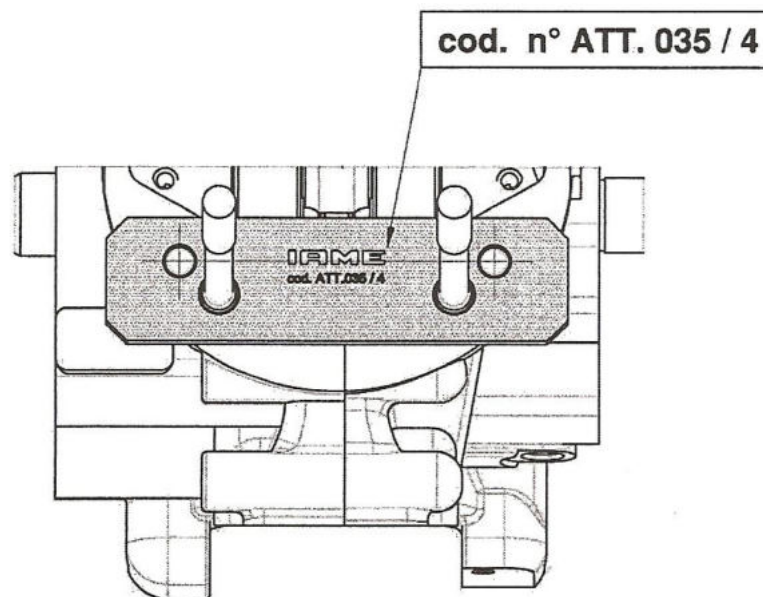

CONTROL OF THE HEIGHT OF THE CRANKSHAFT CYLINDER PLANE
CONTRÔLE DE LA HAUTEUR DU PLAN CYLINDRE SUR LE CARTER

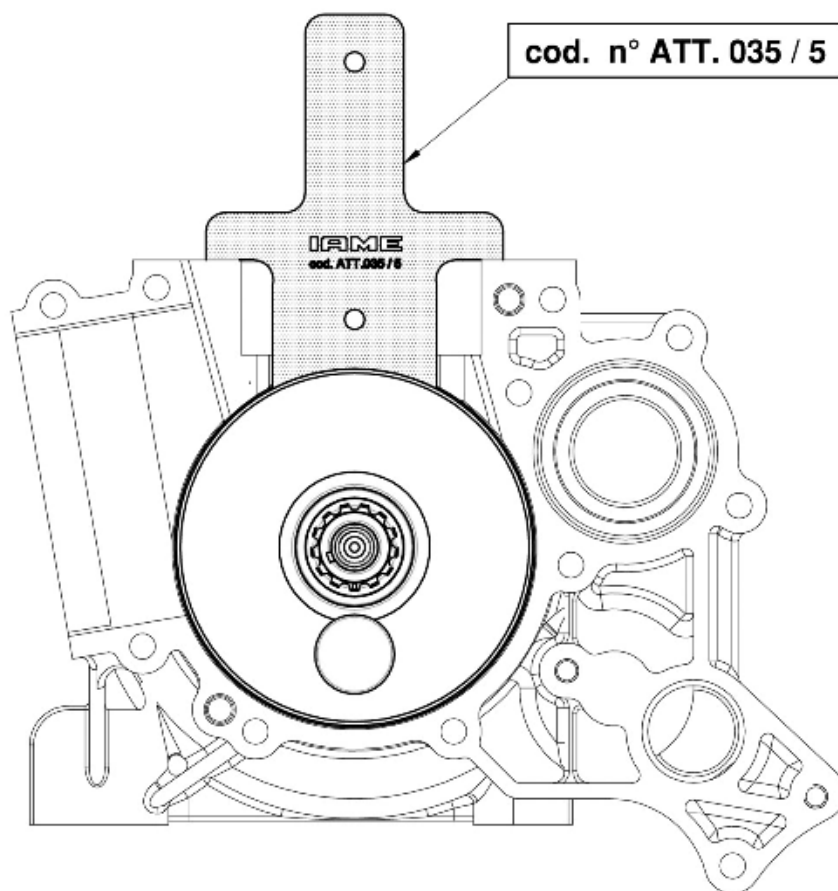

CHECKING OF THE REEDS VALVE PLANE
CONTRÔLE DU PLAN DU LOGEMENT DE LA BOITE À CLAPETS

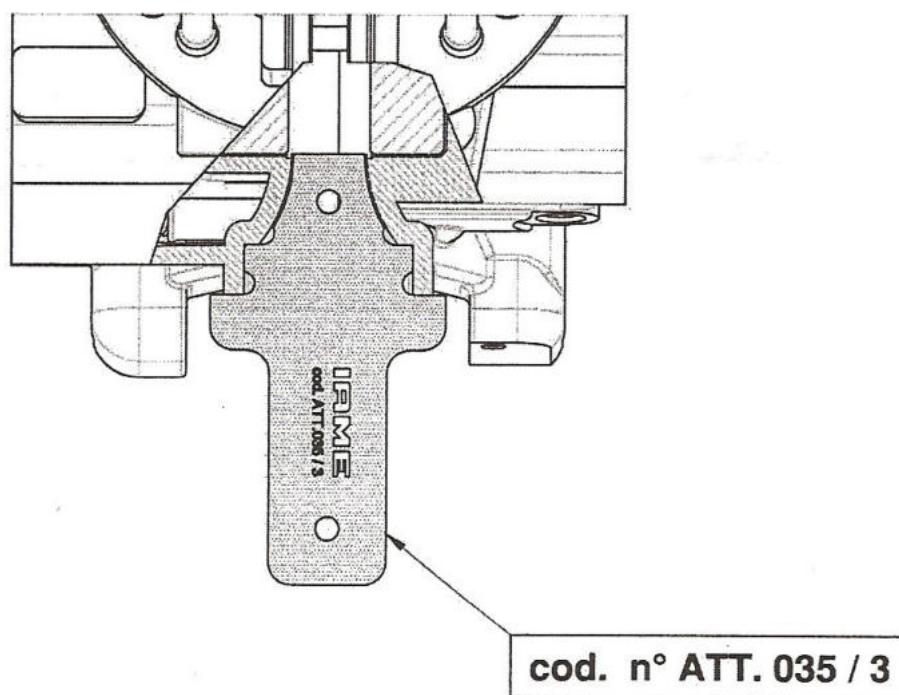

CHECKING OF THE POSITION OF SELETTRA DIGITAL "S" PHASE MARKING
CONTRÔLE DE LA POSITION DU MARQUAGE DE PHASE
SELETTRA DIGITAL "S"

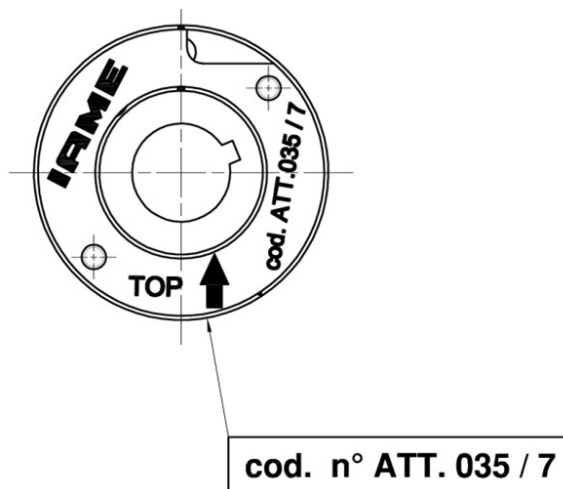

VENTURI SHAPE CONTROL OF TILLOTSON HW-27A CARBURETTOR
CONTRÔLE DU VENTURI DU CARBURATEUR TILLOTSON HW-27A

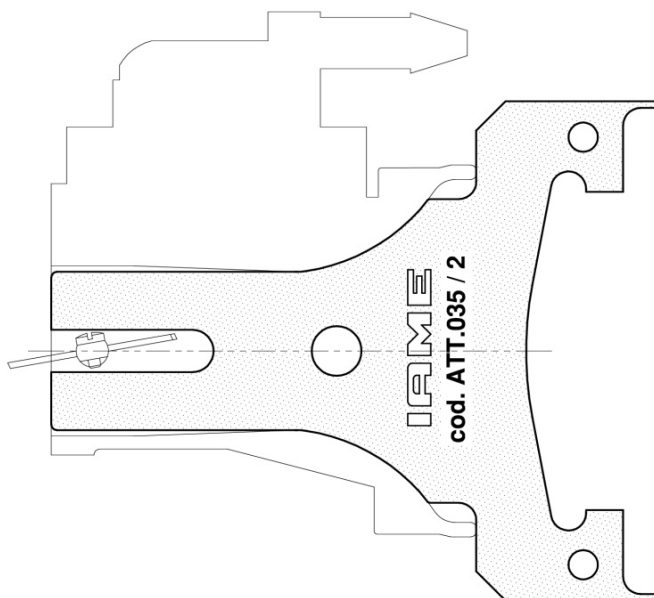

CHECKING OF THE HEIGHT OF THE ATOMISER – GO IF IT'S OK
CONTRÔLE DE LA HAUTEUR DU PULVERISATEUR
IL PASSE S'IL EST CONFORME

ATT.035 / 12

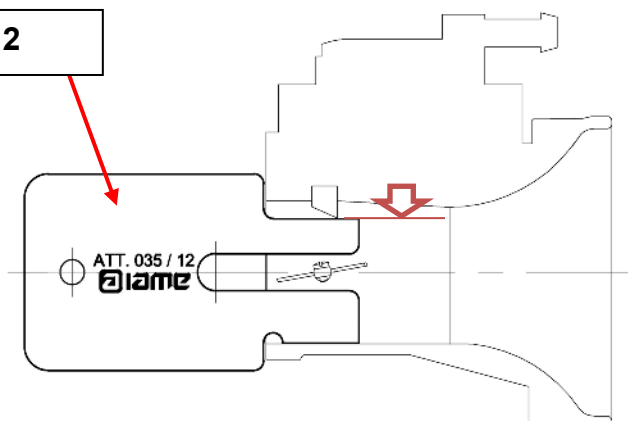

CHECK HOLE OF ATOMIZER
OUTIL DE VÉRIFICATION DE TROU DU PULVERISATEUR

Pass Side – OK
Côté passe - Conforme

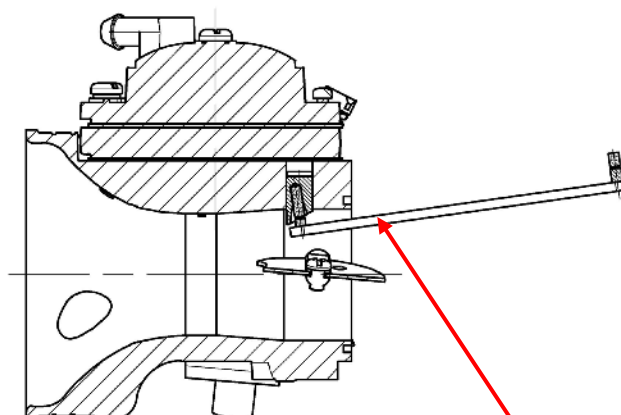

No Pass Side - OK
Pas de passe côté - Conforme



ATT.035 / 19

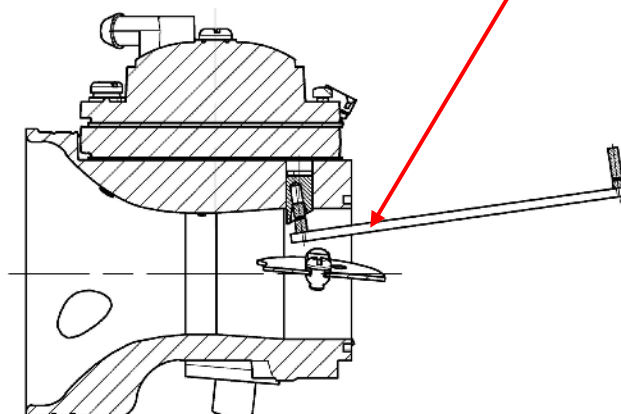

EXHAUST FITTING WITH Ø24 RESTRICTOR CHECKING TOOL
CONTRÔLE DU RACCORD D'ÉCHAPPEMENT AVEC RESTRICTEUR Ø24

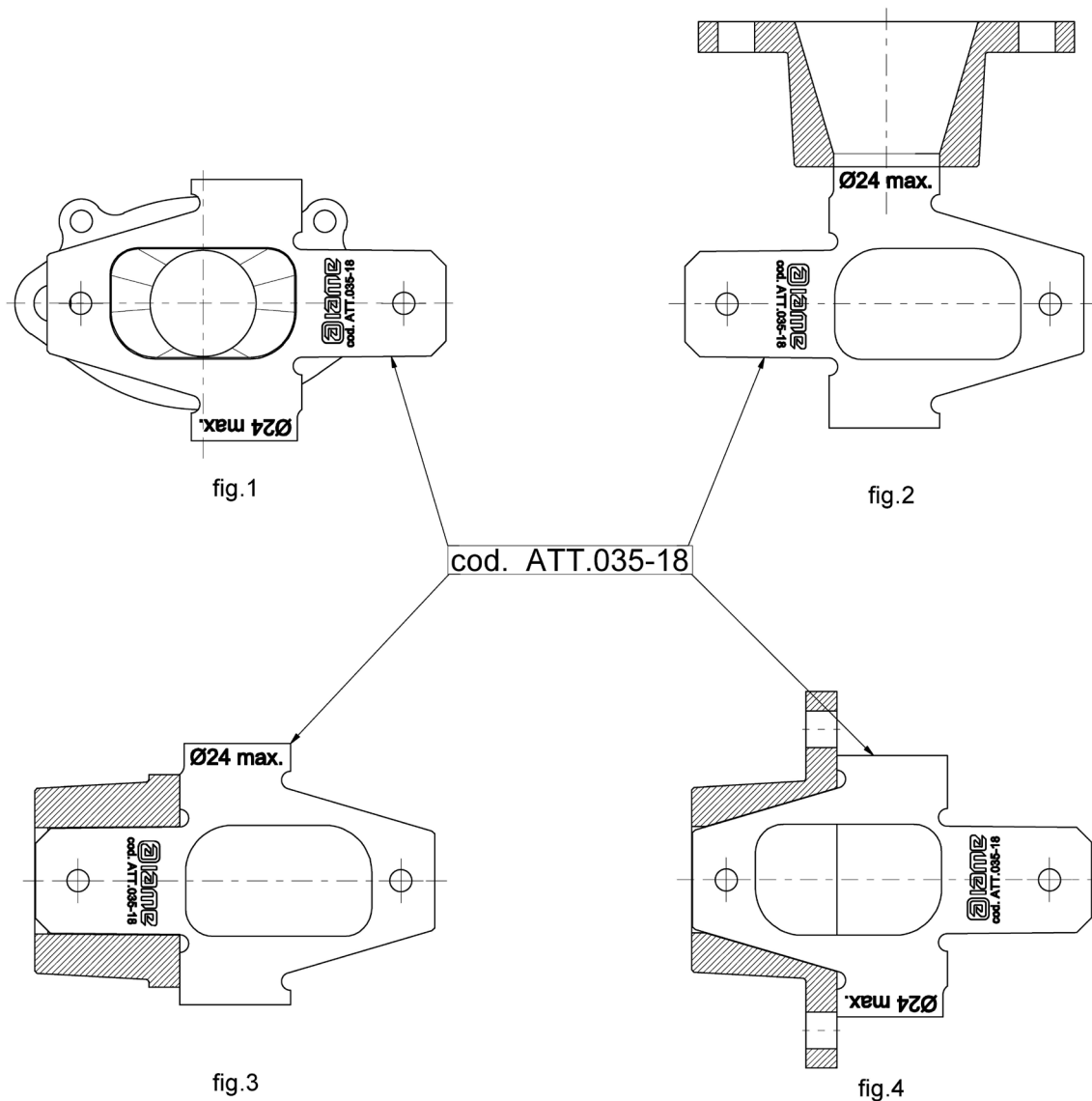

THE NO-GO GAUGE MUST NOT ENTER INTO THE EXHAUST RESTRICTOR, (FIG.2);
VERIFIEZ QUE LE CALIBRE N'ENTRE PAS DANS LE TROU DU RESTRICTEUR D'ÉCHAPPEMENT.

CHECK THAT THE TOOL MATCHES THE SHAPE OF THE EXHAUST MANIFOLD, (FIG.1,3 AND 4).
VERIFIEZ QUE LA FORME DU RESTRICTEUR D'ÉCHAPPEMENT EST LA MEME DE L'OUTIL