

FAR TOOLS®

- FR Ponceuse à bande et à disque (Notice originale)
- EN Belt and disc sander (Original manual translation)
- DE Gürtel und Disc Sander (Übersetzung aus dem Original-Anleitung)
- ES Correa y chorreadora del disco (Traducción del manual de instrucciones originale)
- IT Cintura e disc sander (Traduzione dell'avvertenza originale)
- PT Cinto e lixadeira de disco (Tradução do livro de instruções original)
- NL Riem en schijf sander (Vertaling van de originele instructies)
- EL Ζώνη και Sander δίσκων (Μετάφραση από τις πρωτότυπες οδηγίες)
- PL Pas i plyty sander (Tłumaczenie z oryginalnej instrukcji)
- FI Vyö ja levyin sander (Käännös alkuperäisestä ohjeet)
- SV Bälte och skiva sander (Översättning från originalinstruktioner)
- BU Колан и диск Сандер (Превод на оригиналните инструкции)
- DA Bælte og disc sander (Oversættelse fra oprindelige brugsanvisning)
- RO Centura și disc de slefuit (Traducere din instrucțiunile originale)
- RU Пояса и диск шлифовальный (Перевод с оригинальной инструкции)
- TU Kemer ve disk sander (Orijinal talimatlar çeviri)
- CS Pás a disc sander (Překlad z originálního návodu)
- SK Pás a kotúč brúska (Preklad z originálneho návodu)
- HE תווירוקם תוארומה סוגרת) דנס קסיד, הרונה
- AR (تعليمات العمل) تم عملها) دناس صردقلا و مزح
- HU Biztonsági öv és tárcsa sander (Fordítás az eredeti utasítások)
- SL Pas in disk hoblovanje (Prevod iz izvornih navodil)
- ET Võõ ja plaadi Sander (Tõlge originaal juhiseid)
- LV Drošības jostas un disku sander (Tulkojumā no instrukcijas oriģinālvalodā)
- LT Diržo ir diskų smėliapūtė (Vertimas iš originalių instrukcijas)
- HR Brusilica s trakom i diskom (Prijevod prema originalne upute)



BDS 150
Professional Machine



© FAR GROUP EUROPE

113203-C-20230509



fartools.com



FIG. A



FR
Éléments d'emballage



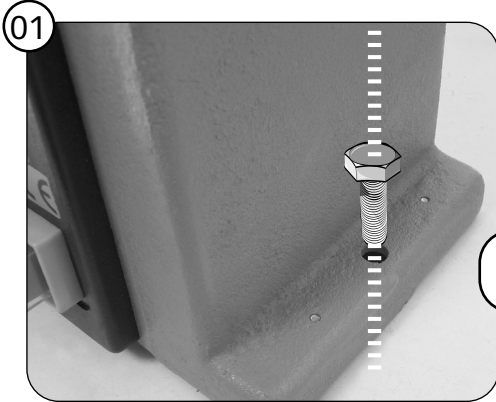
FR
Cet appareil se recycle

A DÉPOSER EN MAGASIN
OU
A DÉPOSER EN DÉCHÈTÈRE
Points de collecte sur www.quefairemesdechets.fr
Privilégiez la réparation ou le don de votre appareil !

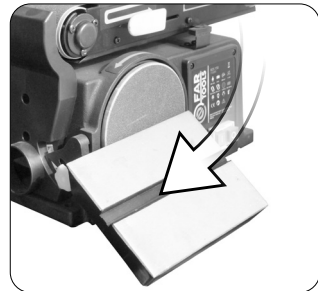
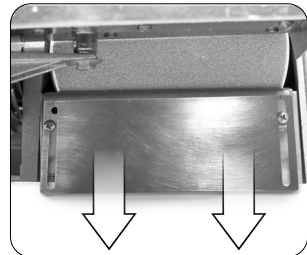
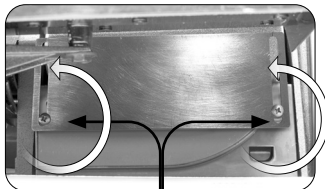
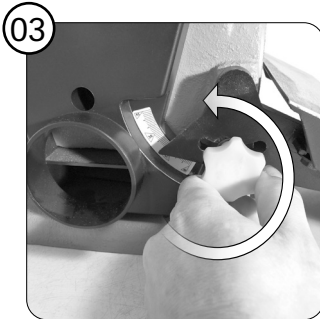
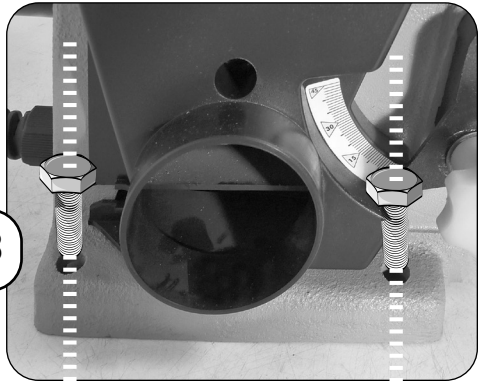




FIG. B

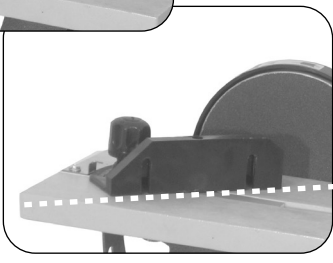
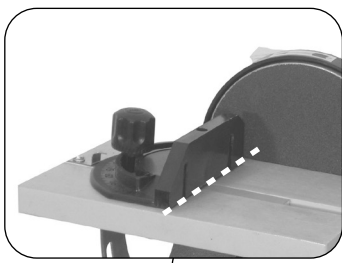
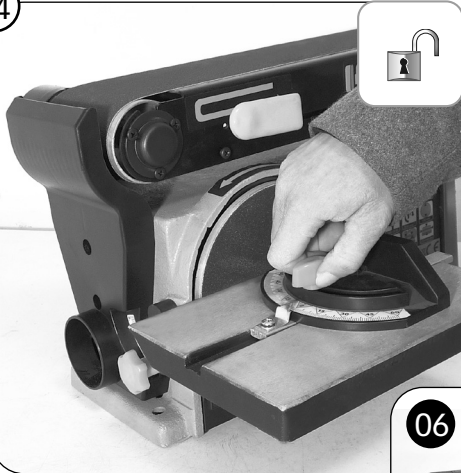


x 3





04

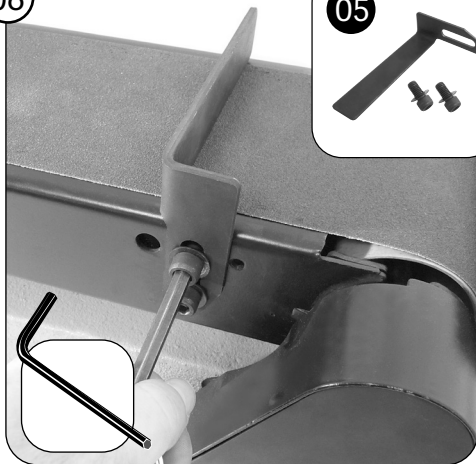


05





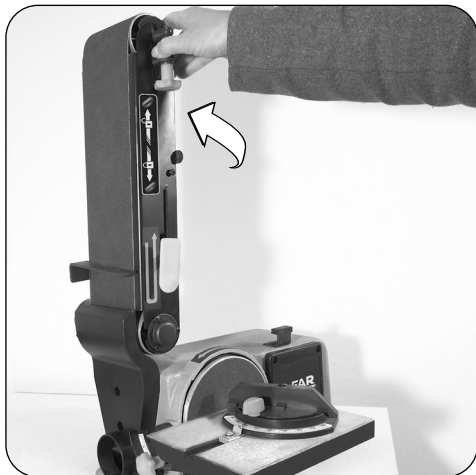
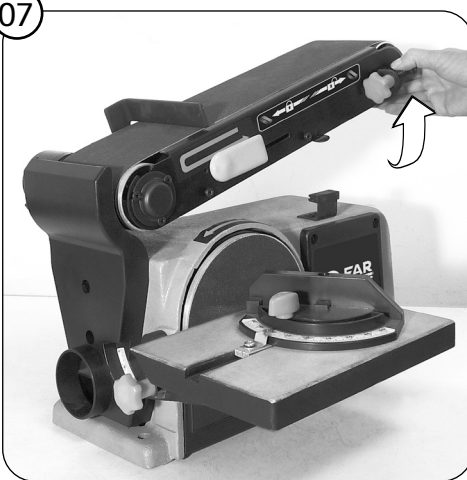
06



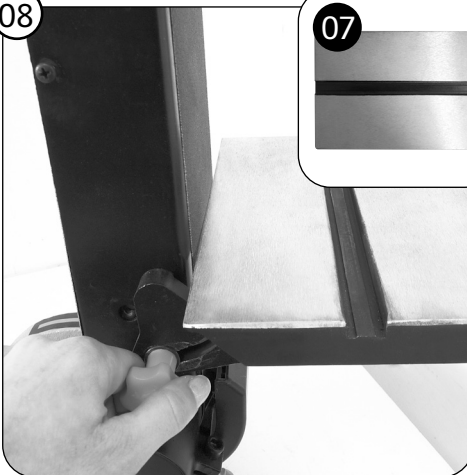
05



07



08



07



FIG. C

01



02

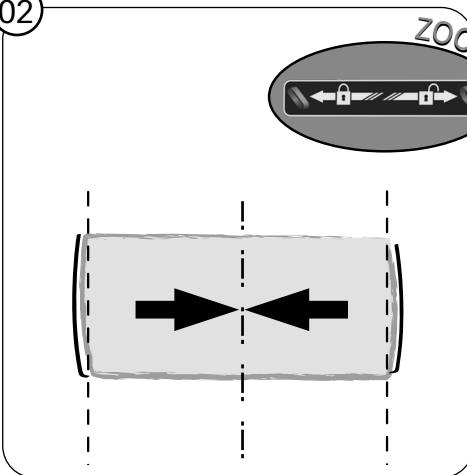




FIG. D

01

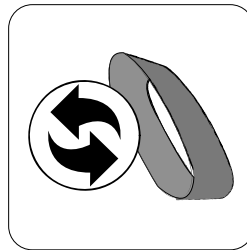
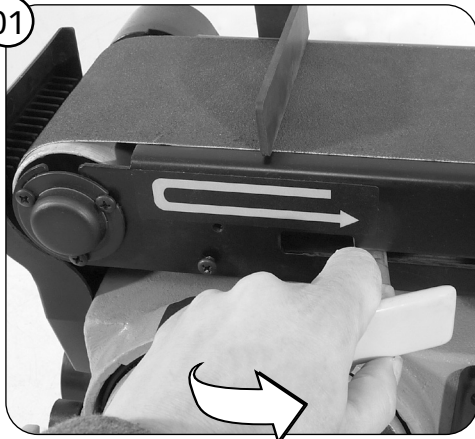
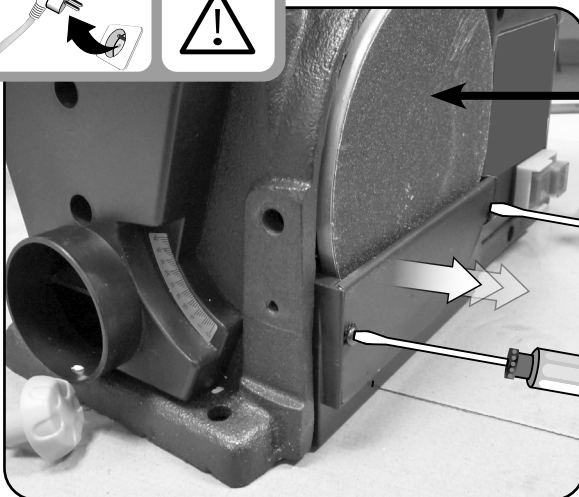
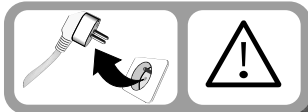


FIG. E



113259 :
x2 A40
+ x2 A80
+ x2 A120

113360 :
A120

113361 :
A80

113362 :
A40

FIG. F








Transport de la machine
Vervoeren Machine
Transporte de la máquina
Transporte da máquina
Il trasporto della macchina
Transportation of the Machine



GW 12,5 kg
NW 11,5 kg





	<p>Tension et fréquence assignée: Nominal frequency and power: Nennspannung und Nennfrequenz : Tensión y frecuencia fijada: Tensione e frequenza assegnata: Tensão e frequência fixa: Aangewezen spanning en frequentie: ΟΝΟΜΑΣΤΙΚΗ ΤΑΣΗ ΚΑΙ ΣΥΧΝΟΤΗΤΑ: Napięcie i częstotliwość przydzielona: Jännite ja määrätty taajuus: Angiven spänning och frekvens: Anført spænding og frekvens: Tensiune și frecvență de lucru:</p>	<p>Заданное напряжение и частота: Tahsis gerilimi ve frekans: Stanovené napětí a frekvence: Stanovené napätie a frekvencia: Merkespenning og merkefrekvens: الغالبية والذبذبة المبرمجة. Névfleges feszültség és frekvencia: Napetost in določena frekvenca: Консумирано напрежение и честота : Määratud pinge ja sagedus Nustatyta įtampa ir dažnis Noteiktais spriegums un frekvence. Napon i nazivna frekvencija:</p>	230 V ~ 50 Hz
	<p>Puissance assignée: Nominal power: Nennleistung: Potencia fijada: Potenza assegnata: Potência assinada: Onbelast toerental: ΟΝΟΜΑΣΤΙΚΗ ΙΣΧΥΣ: Prędkość na biegu jałowym: Teho: Angiven effekt: Anført styrke: Putere de lucru:</p>	<p>Заданная мощность: Tahsis edilen güç: Stanovený príkon: Predpísaný výkon: Merkeeffekt: القدرة المبرمجة. Névfleges teljesítmény : Določena jakost: Консумирана мощност: Määratud võimsus. Nustatyta galia Noteiktā jauda Nazivna snaga:</p>	370 W
	<p>Vitesse à vide: No-load speed: Leerlaufdrehzahl: Velocidad vacía: Velocità a vuoto: Velocidade no vácuo: Leerlaufdrehzahl: ΤΑΧΥΤΗΤΑ ΑΔΡΑΝΕΙΑΣ: Prędkość bez obciążenia: Tyhjäkäyntinopeus Tomgångshastighet: Hastighed i ubelastet tilstand: Viteza în gol:</p>	<p>Скорость вращения на холостом ходу: Boşalma hızı: Rychlost naprázdno: Rýchlosť pri chode naprázdno: Tomgångshastighet: السرعة على الفارغ. Üres sebesség: Prosti tek: Скорост на празни обороти: Kiirus tühikäigul Tuščio prietaiso greitis Tukšgaitas ātrums Brzina praznog hoda:</p>	2980 min ⁻¹
	<p>Lire les instructions avant usage : Read the instructions before use : Vor Einsatz des Geräts Anweisung lesen : Léase las instrucciones antes de usar : Leggere le istruzioni prima dell'uso : Ler as instruções antes da utilização : Lees voor het gebruik de instructies : ΔΙΑΒΑΣΤΕ ΤΙΣ ΟΔΗΓΙΕΣ ΠΡΙΝ ΑΠΟ ΤΗ ΧΡΗΣΗ: Zapoznać się instrukcją przed użyciem : Lue ohjeet ennen käyttöä : Läs anvisningarna före användning : Læs instruktionerne før brug Înainte de utilizare, citiți instructiunile :</p>	<p>Внимательно прочитайте следующие инструкции : Kullanmadan talimatları okuyunuz : Pozorně si přečtěte následující pokyny : Pred použitím si precítajte pokyny : Les bruksanvisningen før bruk: اقرأ التعليمات قبل الاستخدام. használat előtt olvassuk el az utasítást : Pred uporabo preberite ustrezna navodila Прочетете указанията за употреба : Enne kasutamist lugege instruksiooni Prieš naudojimą perskaityti instrukciją izlasīt instrukcijas pirms lietošanas Pročitati upute prije uporabe:</p>	X
	<p>Conformité européenne Conforms to EC standards : CE-Konformität : Cumple con las directivas CE : Conforme alle norme CE : Conforme às normas CE : Voldoet aan de EG-normen : ΕΥΡΩΠΑΪΚΗ ΣΥΜΜΟΡΦΩΣΗ Zgodność z normami CE : EU-standardien mukainen : EU-standardien mukainen : Overholder EU standarderne : Conform cu normele europene:</p>	<p>соответствие европейским стандартам: Avrupa uygunluk : evropská shoda : európska dohoda : Europeisk konformitet طابق للمواصفات الأوروبية. evropska ustreznost : európai megfeleléség : Съответствие с европейските норми : Euroopa Liidu vastavusmärk Europinių normų atitikima Atbilstība Eiropas standartiem Evropska sukladnost</p>	X





		ø 150 mm
--	--	----------

		2980 min ⁻¹
--	--	------------------------

		450 m/min
--	--	-----------

		915 x100 mm
--	--	-------------

		0 -> 45°
--	--	----------

		226 x 160 mm
--	--	--------------

	<p>Danger : Danger : Gefahr : Peligro : Pericolo : Perigo : Gevaar : ΚΙΝΔΥΝΟΣ : Niebezpieczeństwo : Vaara : Fara : Fare : Pericol :</p>	<p>Opacho : Tehlike : Nebezpečí : Nebezpečnost : Fare : خطر : Veszély : Nevarnost : Опасност : Ohht : Pavojus : Bistamiba : Opasnost :</p>	X
--	---	--	---





	Classe d'isolement : 1 Insulation class : 1 Isolierung klasse : 1 Aislamiento clase : 1 Isolamento classe : 1 Isolamento classe : 1 Isolatje Klasse : 1 Ergaleio τάξη : 1 Izolacja Klasy : 1 Eristysluokka : 1 Isolering Klass : 1 Isoleringsklasse 1 Clasă izolatje : 1	Класс изоляции 1 : Yalıtım derecesi :1 Třída izolace :1 Izolačný systém 1 סוג בידוד :1 فئة العزل :1 Szigetelési osztály :1 Razred izolacije :1 Инструмент Клас :1 Isolatsiooniklass 1 Izolācijas rūšis 1 Izolācijas klase 1 Izolacija klasa: 1	X
--	--	--	---

	Poids : Weight : Gewicht : Peso : Peso : Gewicht : ΒΑΡΟΣ : Masa : Paino : Vikt : Vægt : Greutate :	Bec : Ağırlık : Hmotnost : Hmotnosť : Vekt: الوزن : Súly : Teža : Терло : Raskus Svoris Svars Težina	GW 12,5 kg - NW 11,5 kg
--	---	--	-------------------------

	Niveau de pression acoustique : Acoustic pressure level : Schalldruckpegel : Nivel de presión acústica : Livello di pressione acustica : Nivel de pressão acústica : Niveau akoestische druk : ΣΤΑΘΜΗ ΗΧΗΤΙΚΗΣ ΠΙΕΣΗΣ: Poziom mocy akustycznej : Käytä kuulosuojaimia: Ljudtrycksnivå : Lydtryk : Nivel presiune acustică :	Уровень акустического давления. : Akustik basınç seviyesi : Hladina akustického tlaku : Hladina akustického tlaku : Lydtrycksnivå: مستوى الضغط السمعي: A hangnyomás szintje : Nivo akustičnega pritiska: Равнище на акустично налягане : Helirõhu nivoo Akustinio spaudimo lygis Akustiskā spiediena līmenis Razina zvučnog tlaka:	79,9 dB (A)
--	---	--	-------------

	Niveau de puissance acoustique : Acoustic power level : Schalleistungspegel : Nivel de potencia acústica : Livello di potenza acustica: Nivel de potência acústica: Niveau akoestisch vermogen : Επίπεδο ισχύος ήχου: Poziom mocy akustycznej : Käytä suojalaseja : Ljudstyrkenivå : Lydstyrke : Nivel putere acustică :	уровень мощности звука : Akustik basınç seviyesi : Hladina zvukového výkonu: Hladina zvukového výkonu: Lydeffektivnivå: مستوى الضجيج: a hangnyomás szintje : Nivo akustične jakosti : Равнище на вибрации : Helivõimsuse nivoo Triukšmo lygis Akustiskās jaudas līmenis Razina zvučne snage:	91,1 dB (A)
--	--	--	-------------

NIVEAU SONORE D'ÉMISSION :

A VIDE

Pression acoustique LpA poste opérateur
Incertitude

79,9 dB
3

Puissance acoustique LWA
Incertitude

91,1 dB
3


Valeurs déterminées suivant le code d'essai de l'annexe B de la norme EN 61029-1 avec emploi des normes de base ISO 11201 et ISO 3744.


Les niveaux de pression acoustique obtenus in situ dépendent:


- Des niveaux réels de la machine considérées, en prenant en compte les incertitudes déclarées;
 - Du local et de l'installation de la machine. Préférez une pièce dont l'acoustique est plus feutrée.
- Évitez les pièces vides à grande résonance. Placez vous auprès d'une fenêtre le cas échéant.
- Des outils montés, des pièces travaillées, des réglages choisis,...






	<p>Porter des lunettes de sécurité : Wear protective eyewear : Schutzbrille tragen : Llevar puestas gafas protectoras : Portare de gli occhiali di sicurezza : Utilizar óculos de segurança : Draag een veiligheidsbril : ΦΟΡΑΤΕ ΠΡΟΣΤΑΤΕΥΤΙΚΑ ΓΥΑΛΙΑ: Zakładać okulary ochronne : Käytä suojalaseja : Använd skyddsglasögon : Der skal benyttes sikkerhedsbriller : Purtati ochelari de protectie :</p>	<p>Наденьте защитные очки : Güvenlik gözlükleri takın : Používejte bezpečnostní brýle : Noste ochranné okuliare : Bruk vernebriller: حَمَلْ نِظَارَاتٍ وَقَايِمَةَ. Viseljen védőszemüveget : Nositi zaščitna očala : Да се използват защитни очила : Kandke kaitseprille Nešioti apsauginius akinius Valkät aizsargbrilles Nositi zaštitne naočale:</p>	×
---	--	--	---

	<p>Porter un masque anti-poussière : Wear a dust mask : Staubschutzmaske tragen : Llevar puesta una careta de protección contra el polvo : Indossare una mascherina anti-polvere : Utilizar uma máscara anti-poeira : Draag een stofmasker : ΦΟΡΕΣΤΕ ΜΑΣΚΑ ΓΙΑ ΤΗ ΣΚΟΝΗ: Zakładać maskę przeciwpylową Käytä pölysuojust : Bär mask mot damm : Der skal benyttes beskyttelsesmaske mod støv: Purtati mască anti-praf :</p>	<p>Наденьте респиратор : Toza karşı maske takın : Používejte masku proti prachu : Noste ochrannú masku proti prachu : Bruk en støvmaske: لبس قناعاً مضاداً للغبار. Viseljen porvédő maszktot Nositi zaščitna masko proti prahu: Да се използва защитна маска : Kandke tolmumaski. Dëvëti respiratorių Valkät aizsarg masku pret putekļiem Nositi masku za zaštitu od prašine:</p>	×
---	---	---	---

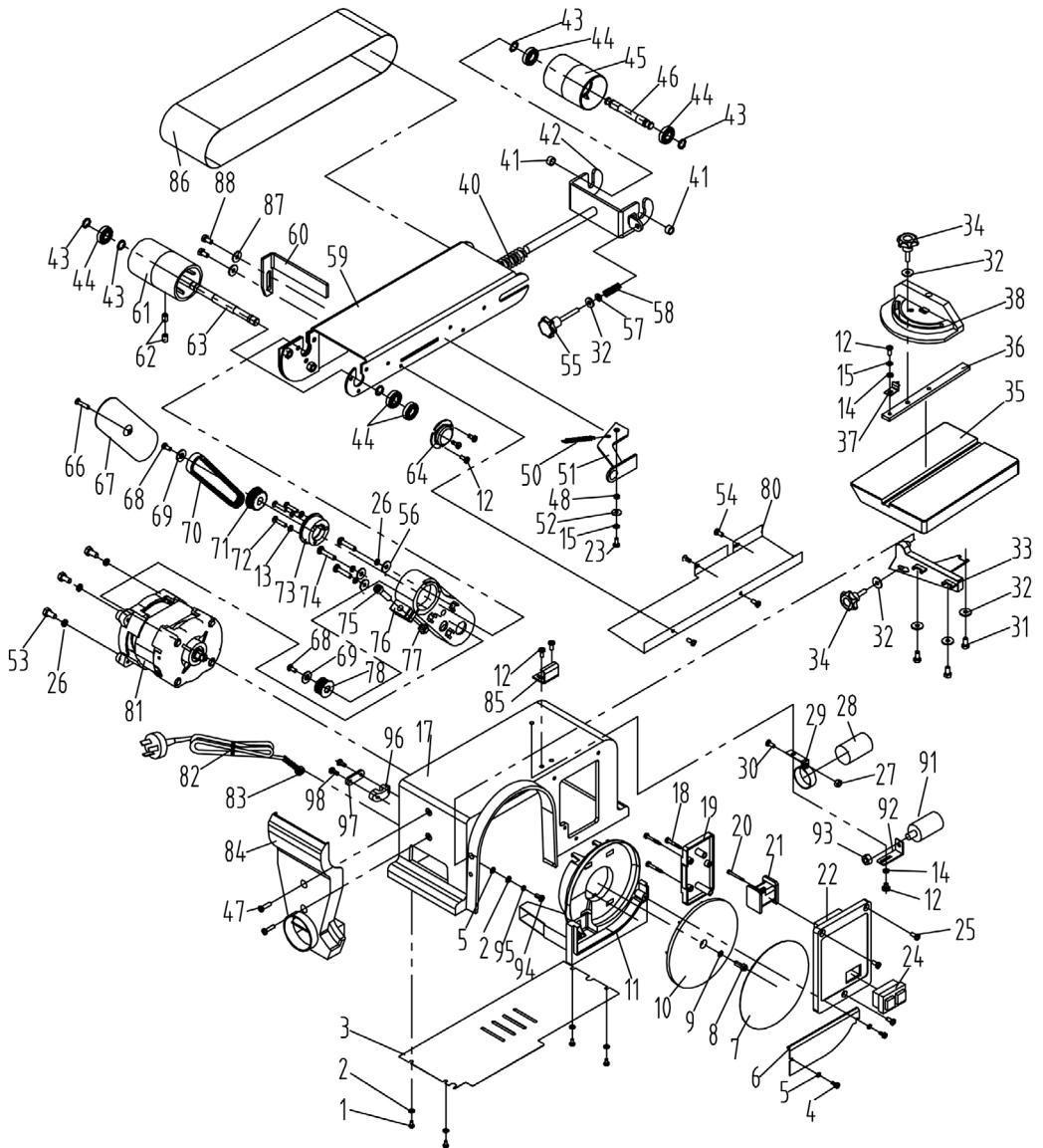
	<p>Porter une protection auditive : Wear hearing protective equipment: Gehörschutz tragen: Llevar puesta una protección auditiva: Portare una protezione uditiva: Utilizar uma protecção auditiva: Draag gehoorbeschermers: ΦΟΡΑΤΕ ΠΡΟΣΤΑΣΙΑ ΑΚΟΗΣ: Zakładać słuchawki ochronne Käytä kuulosuojaimia: Bär hörselskydd: Der skal benyttes høreværn: Purtati căști de protecție auz:</p>	<p>наденьте средства звуковой защиты: İşitsel koruma aleti takın: Používejte ochranu sluchu: Noste ochranné slúchadlá: Bruk hørselsvern: لبس خوذة ضرخ الخصىج Viseljen fülvédőt Nositi zašito ušes: Да се използва слухови защитни средства: Kandke kõrvakaitset Nešioti apsaugą nuo triukšmo Valkät dzirdes aizsarglīdzekli Nositi štītņike protiv buke:</p>	×
---	--	--	---

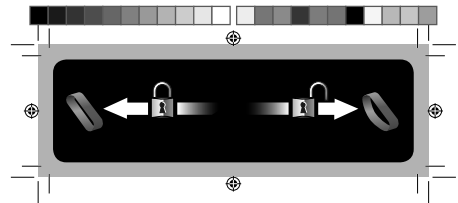
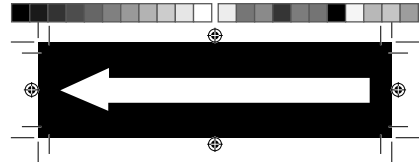
	<p>Porter des gants : Use rubber gloves : Schutzhandschuhe tragen : Llevar guantes de protección : Indossare i guanti di protezione : Utilizar luvas de protecção : Draag veiligheidshandschoenen : ΦΟΡΩΝΤΑΣ ΓΑΝΤΙΑ: Używać rękawic ochronnych : Käytä suojakäsineitä : Använd skyddshandskar : Der skal benyttes handsker : Purtati mănuși :</p>	<p>Наденьте перчатки : Eldiven takın : Noste rukavice : Noste rukavice : Bruk hansker: لبس قفازات. Viseljen kesztyű t Nositi rokavice: а се използват предпазни ръкавици : Kandke kindaid Müvëti pirštines Valkät cimdus Nositi zašitne rukavice:</p>	×
---	---	---	---





BDS 150







DECLARATION DE CONFORMITE
 VERKLARING VAN OVEREENSTEMMING
 DECLARACION DE CONFORMIDAD
 DICHIARAZIONE DI CONFORMITA
 KONFORMITÄSERKLÄRUNG
 DECLARATION CONFORMITY
 DECLARAÇÃO DE CONFORMIDADE
 DEKLARACJA ZGODNOSCI Z NORMAMI
 OM ÖVERENSSTÄMMELSE
 VAATIMUSTENMUKAISUUSVAKUUTUS
 ÖVERENSSTEMMELSESERKLÆRING
 ΔΗΛΩΣΗ ΣΥΜΜΟΡΦΩΣΗΣ

DECLARAȚIE DE CONFORMITATE
 VYHLÁSENIE ZHODY
 Декларация соответствия
SAMSVARSERKLÆRING
 Uygunluk beyanı
 التصريح بال مطابقة
 PROHLÁSENÍ SHODY
 EGYZŐSÉGI NYILATKOZAT
 Декларация за съответствие с нормите
 IZJAVA O SKLADNOSTI
 DEKLARACIJA
 ATITIKTIES DEKLARACIJA
 KINNITUS
 IZJAVA O SUKLADNOSTI

Le soussigné,
 Ondergetekende,
 Der Unterzeichner,
 O abaixo assinado,
 Undertecknad,
 Долуподписаният
 Undertegnede
 Subseminatul,
 Я, нижеподписавшийся,
 Imzalayan,
 Niže podepsány,
 Toliau pasirašęs

Personne autorisée à constituer
 le dossier technique :
 Christophe HUREL



FAR GROUP EUROPE
 192, Avenue Yves Farge
 37700 St. Pierre-des-Corps
 FRANCE

El suscrito,
 Il sottoscritto,
 The undersigned,
 Nínej podpísany
 Allekirjoittanut,
 Ο ΚΑΤΩΘΙ ΥΠΟΓΡΑΦΜΕΝΟΣ,
 Nižše podpisany
 Undertegnede,
 الموقّع أدناه
 Alulirott,
 Podpisani,
 Apakšā pārakstījies
 allakirjutanu
 Dolje potpisani,

Declara por la presente que,
 Dichiare che,
 Declares that,
 Oowiadcza niniejszym, że
 Ilmoitetaan täten että,
 Δια του παρόντος δηλώνει ότι,
 týmto vyhlásuje, že
 Erklærer herved at,
 я, нижеподписавшийся, что
 Erklær hermed at,
 Declara prin prezenta că,
 настоящим подтверждаю, что
 Mevcut belgeyle beyan ediliyor ki,
 tímto prohlašuje, že,
 Pareiškia, kad,
 Ar šo apliecinā, ka,
 Kinnitab, et
 izjavljuje u ovom dokumentu da je

Déclare par la présente que,
 Verklaart hiermede dat,
 Erklärt hiermit daß,
 Declara pela presente que,
 Förklarar härmed att
 Заявлява с настоящото
 erklærer hermed, at
 Declar prin prezenta că,
 настоящим подтверждаю, что
 Mevcut belgeyle beyan ediliyor ki,
 tímto prohlašuje, že,
 Pareiškia, kad,

Combiné Ponceur / Belt and disc sander / Combschleifer / Lijadora Combinada / Levigatrice combinata / Lixasdeira / Bandschuurmachine /

Σύνθετη μηχανή λείανσης / Bandschuurmachine met schuurschijf / Lautas/nauhahiomakone / Bandslipmaskin med sliptallrik /

Комбинирана шлифовъчна машина / Kombineret pudsemaskine / Mašina de šlefuit combinată cu polizor / Комбинированный шлифовальный станок /
 Kombiniel parlatna makinesi / Brusný robot / Kombinovaná brúška / ترکیبی دروغچرخ / Kombinált csiszoló / Žaga reziljača / Kombineeritud lihviija /
 Kombinuota (mišri) grežimo mašina / Kombinētā slīpmašina

code

FARTOOLS / 113203 / BDS 150 / MM491GL

Est conforme et satisfait aux directives et normes CE,
 In overeenstemming is met en Voldoet aan EG richtlijnen,
 Den følgende EU-Bestimmungen entspricht,
 Respeita e está em conformidade com as normas CE,
 Överensstämmer med och uppfyller EG-standarder,
 Съответства и отговаря европейските норми
 Er i overensstemmelse med og overholder EU standarderne
 полностью соответствует и удовлетворяет
 требованиям стандартов ЕС
 CE şartlara uygundur,
 odpovídá normám ES.
 Atitinka ir atitinka EB direktyvas ir standartus,

Cumple con la directivas de la CE,
 E conforme alle direttive CEE,
 Complies with the EEC directives and standards,
 Odpowiaa normom UE,
 Täyttää EU-vaatimukset,
 ΣΥΜΜΟΡΦΩΝΕΤΑΙ ΚΑΙ ΙΚΑΝΟΠΟΙΕΙ ΤΙΣ ΟΔΗΓΙΕΣ ΚΑΙ ΤΑ ΠΡΟΤΥΠΑ CE,
 zodpovedá normám ES.
 Samsvarer med og tilfredsstiller CE-direktiver og standarder,
 بان الجهاز مطابق و يلبي معايير مجموعة الدول الأوروبية
 kielgitti a CE szabványok előírásait.
 Je v skladu z in izpolnjuje norme Evropske skupnosti.
 Atbilst un atbilst EK direktīvas un standartus,
 Vastab ja vastab EU direktīviņdeļe ja standartiteļe,
 Sukladan i ispunjava direktive i standarde CE,

2006/42/EC 2014/30/EU 2011/65/EU
 2015/863/UE

EN IEC 55014-1:2021
 EN IEC 55014-2 :2021
 EN IEC 61000-3-2 :2019+A1
 EN61000-3-3 :2013
 EN62841-1:2015
 EN ISO 12100:2010

Christophe HUREL,
 Président Directeur Général
 09/04/2022
 Fait à St. Pierre-des-Corps



GARANTIE - WARRANTY



FR. GARANTIE

Cet outil est garanti contractuellement contre tout vice de construction et de matière, à compter de la date de vente à l'utilisateur et sur simple présentation du ticket de caisse. La garantie consiste à remplacer les parties défectueuses. Cette garantie n'est pas applicable en cas d'exploitation non conforme aux normes de l'appareil, ni en cas de dommages causés par des interventions non autorisées ou par négligence de la part de l'acheteur. La garantie ne s'applique pas sur les dommages causés par une défaillance de l'outil.

DE. GARANTIE

Die Garantiezeit für dieses Gerät in bezug auf Konstruktions- und Materialfehler beträgt lt. Vertrag bei Vorlage des Kassensbons. Die Garantieleistung besteht im Ersatz schadhafter Teile. Die Garantie erlischt bei einem Einsatz des Geräts, der nicht normentsprechend ist, bei Schäden, die auf unsachgemäße Eingriffe zurückzuführen sind bzw. bei Nachlässigkeit seitens des Käufers. Die Garantie erstreckt sich nicht auf Schäden, die auf Fehlfunktionen des Geräts zurückzuführen sind.

IT. GARANZIA

Quest' attrezzo è garantito per contratto contro qualsiasi difetto di costruzione e di materia, a partire dalla data di vendita all'utente e su semplice presentazione dello scontrino. La garanzia consiste nel sostituire le parti difettose. Questa garanzia non è applicabile in caso di sfruttamento non conforme alle norme dell'apparecchio, né in caso di danni causati da interventi non autorizzati o da negligenza da parte dell'acquirente. La garanzia non si applica ai danni causati da un'avarìa dell'attrezzo.

EN. GARANTIE

This tool is guaranteed, in writing, against any defect in manufacture or parts from the date of sale, upon simple presentation of the sales slip. The guarantee is limited to the replacement of faulty parts. This guarantee is not applicable in the event of usage which is not conform with the intended usage of the apparatus, nor in the event of damage caused by unauthorized servicing or negligence on behalf of the purchaser. This guarantee does not apply to any damage caused by the failure of this tool.

ES. GARANTIA

Esta herramienta se garantiza contractualmente contra todo defecto

de construcción y materia, a partir de la fecha de venta a l' usuario y sobre simple presentación del recibo de caja. La garantía consiste en sustituir a las partes defectuosas. Esta garantía no es aplicable en caso de explotación no conforme a las normas del aparato, ni en caso de daños causados por intervenciones no autorizadas o por negligencia por parte del comprador. La garantía no se aplica sobre los daños causados por un fallo del herramienta.

NL. GARANTIE

Dit gereedschap heeft een garantie tegen constructiefouten en materiaaldefecten, die geldig is vanaf de aankoopdatum door de gebruiker, op vertoning van de kassabon. De garantie betreft de vervanging van de defecte onderdelen. Deze garantie is niet van toepassing indien het apparaat niet volgens de normen gebruikt is, noch in geval van schade veroorzaakt door onjuist gebruik of nalatigheid van de koper. De garantie is niet van toepassing op schade voortvloeiend uit een defect van het gereedschap.

PT. GARANTIA

Esta ferramenta tem uma garantia contratual contra qualquer defeito de construção e de material, a partir da data de venda ao utilizador e sobre simples apresentação do talão da caixa. A garantia consiste em substituir as partes defeituosas. Esta garantia não é aplicável no caso de exploração não conforme as normas do aparelho, nem em caso de danos causados pelas intervenções não autorizadas ou por negligência da parte do comprador. A garantia não se aplica para os danos causados por uma falha da ferramenta.

EL. ΕΓΓΥΗΣΗ

ΑΥΤΟ ΤΟ ΕΡΓΑΛΕΙΟ ΕΙΝΑΙ ΣΥΜΒΑΤΙΚΑ ΕΓΓΥΗΜΕΝΟ ΓΙΑ ΟΠΟΙΟΔΗΠΟΤΕ ΚΑΤΑΣΚΕΥΑΣΤΙΚΟ ΚΑΙ ΥΛΙΚΟ ΕΛΑΤΤΩΜΑ, ΑΠΟ ΤΗΝ ΗΜΕΡΟΜΗΝΙΑ ΠΩΛΗΣΗΣ ΣΤΟΝ ΧΡΗΣΤΗ ΚΑΙ ΜΕ ΤΗΝ ΕΠΙΔΕΙΞΗ ΤΗΣ ΑΠΟΔΕΙΞΗΣ ΠΩΛΗΣΗΣ. Η ΕΓΓΥΗΣΗ ΣΥΝΙΣΤΑΤΑΙ ΣΤΗΝ ΑΝΤΙΚΑΤΑΣΤΑΣΗ ΤΩΝ ΕΛΑΤΤΩΜΑΤΙΚΩΝ ΕΞΑΡΤΗΜΑΤΩΝ. ΑΥΤΗ Η ΕΓΓΥΗΣΗ ΔΕΝ ΙΣΧΥΕΙ ΣΕ ΠΕΡΙΠΤΩΣΗ ΛΕΙΤΟΥΡΓΙΑΣ ΠΟΥ ΔΕΝ ΣΥΜΜΟΡΦΩΝΕΤΑΙ ΜΕ ΤΑ ΠΡΟΤΥΠΑ ΤΗΣ ΣΥΣΚΕΥΗΣ, ΟΥΤΕ ΣΕ ΠΕΡΙΠΤΩΣΗ ΖΗΜΙΑΣ ΠΟΥ ΠΡΟΚΑΛΕΙΤΑΙ ΑΠΟ ΜΗ ΕΞΟΥΣΙΟΔΟΤΗΜΕΝΕΣ ΕΠΕΜΒΑΣΕΙΣ Ή ΑΜΕΛΕΙΑ ΕΚ ΜΕΡΟΥΣ ΤΟΥ ΑΓΟΡΑΣΤΗ. Η ΕΓΓΥΗΣΗ ΔΕΝ ΙΣΧΥΕΙ ΓΙΑ ΖΗΜΙΕΣ ΠΟΥ ΠΡΟΚΑΛΟΥΝΤΑΙ ΑΠΟ ΑΣΤΟΧΙΑ ΕΡΓΑΛΕΙΟΥ.

PL. GWARANCJA

Narz/dzie jest objte gwarancja na wszelkie wady konstrukcyjne

i materiałowe, licząc od daty sprzedaży u użytkownika i po okazaniu paragonu kasowego. Gwarancja obejmuje wymianę części wybrakowanych. Gwarancja nie znajduje zastosowania w przypadku użytkowania niezgodnego z normami urządzenia, ani w przypadku szkód spowodowanych działaniami niedozwolonymi lub zaniedbaniami ze strony nabywcy. Gwarancja nie obejmuje szkód powstałych z powodu upadku urządzenia.

SV. GARANTI

Detta verktyg har en avtalsenlig garanti mot konstruktions och materialfel, från och med tidpunkten för användarens inköp och genom uppvisning av kassavittot. Garantin består i att ersätta de bristfälliga delarna. Denna garanti gäller inte om användningen inte motsvarar apparatens standarder, inte heller vid skador som orsakas av ej tillåtna ingrepp eller på grund av köparens vårdslöshet. Garantin gäller inte förskador som orsakats av att verktyget fungerat bristfälligt.

FI. TAKUUKU

Tämän laitteen takuu on voimassa sopimukseenmukaisesti kattaen kaikki rakenne- ja materiaaliiviat lukien ostopäivästä kassakuitista vastaan. Takuu sisältää viallisten osien korvaamisen. Takuu ei korvaa ohjeiden vastaista käyttöä eikä valtuuttamattomien henkilöiden käsittelyä tai ostajan huolimattomuudesta aiheutuneita vahinkoja. Takuu ei vastaa myöskään toimintahäiriöistä aiheutuneita vahinkoja.

BU. Гаранция

Този инструмент е под договорна гаранция срещу всякакъв дефект в изработката и използваните материали, считано от датата на продажба на потребителя и само срещу представяне на касовата бележка. Гаранционното обслужване се състои в замяна на дефектните части. Настоящата гаранция не е валидна когато апаратът се използва по начин, несъответстващ на стандарта за работа с него, както и в случай на щети, нанесени от неотризирани лица, или вследствие на проявена небрежност от страна на потребителя.

Гаранцията не покрива щети, произтекли вследствие на техническа неизправност на апарата.

DA. GARANTI

Dette værktøj er dækket af en garantikontrakt for konstruktions- og materialfejl, som gælder fra købsdatoen ved visning af kassebonen. Garantien består i at udskifte de defekte dele. Garantien dækker ikke fejl opstået som følge af anvendelse, som ikke overholder standarderne for apparatet, eller

SERVICE APRÈS VENTE - AFTER SALE SERVICE

FARGROUP EUROPE - 192, Avenue Yves Farge - 37700 St. Pierre-des-Corps - FRANCE

fargroup@fargroup.net



FAR GROUP EUROPE

Une société du groupe **SIGMA**

192, Avenue Yves Farge
37700 St. Pierre-des-Corps
FRANCE

fartools.com

