

FAR TOOLS

- FR** Outil multi fonctions (Notice originale)
- EN** Multi-function tool (Original manual translation)
- DE** Multifunktionswerkzeug (Originalbetriebsanleitung)
- ES** Herramienta multifuncional (Traducción del manual originale)
- IT** Utensile multifunzione (Traduzione dell'avvertenza originale)
- PT** Ferramenta multifuncional (Tradução do livro de instruções original)
- NL** Multifunctioneel gereedschap (Vertaling van de originele instructies)
- EL** Πολυλειτουργικό εργαλείο (Μετάφραση από τις πρωτότυπες οδηγίες)
- PL** Narzędzie wielofunkcyjne (Tłumaczenie z oryginalnej instrukcji)
- FI** Multifunktionsverktøy (Käännös alkuperäisestä ohjeet)
- SV** Multifunktionsverktyg (Översättning från originalinstruktioner)
- BU** Мулти-функционален електроинструмент (Превод на оригиналната инструкция)
- DA** Multifunktionsværktøj (Oversættelse fra oprindelige brugsanvisning)
- RO** Sculă electrică multifuncțională (Traducere din instrucțiunile originale)
- RU** Мультифункциональный инструмент (Перевод с оригинальной инструкции)
- TU** Çok işlevli alet (Orijinal talimatlar çeviri)
- CS** Multifunkční nářadí (Překlad z originálního návodu)
- SK** Multifunkčné náradie (Preklad z originálneho návodu)
- HE** תיורוקמ תוארוהמ סוגרת) ממרטה רוטטת
- AR** (قي لصل آل تامي لعل نم قم جرل) آلة صقل ارتج احيية
- HU** Többfunkciós szerszám (Fordítás az eredeti utasítások)
- SL** Multifunkcijsko orodje (Prevod iz izvornih navodil)
- ET** Multifunktsionaalne tööriist (Tõlge originaal juhiseid)
- LV** Daudzfunkciju instruments (Tulkojumā no instrukcijas oriģinālvalodā)
- LT** Daugiafunkcinis elektrinis įrankis (Vertimas iš originalių instrukcijas)
- HR** Ripper tablice (Prijevod prema originalne upute)



DM 300

Professional Machine



© FAR GROUP EUROPE

115145-2-C-20220516



fartools.com



MERCI !



En choisissant cette Spatule multifonctions **FARTOOLS**, vous permettez d'en diminuer l'impact environnemental !

Livrer cet outil sans mallette permet une réduction de **25 %** du volume de son packaging.

De plus, en retravaillant l'emballage, nous avons supprimé **70 %** des produits dérivés des hydrocarbures.

Ces opérations ont ainsi permis d'abaisser ses émissions de gaz à effet de serre :

- il utilise moins de ressources naturelles,
- son volume transporté est nettement plus faible.

>>> Pour en savoir plus, flashez ce code et retrouvez toutes les informations sur notre site :





01

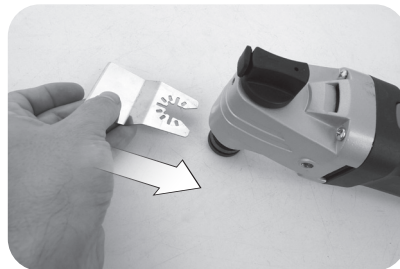
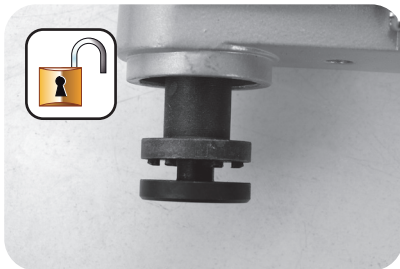
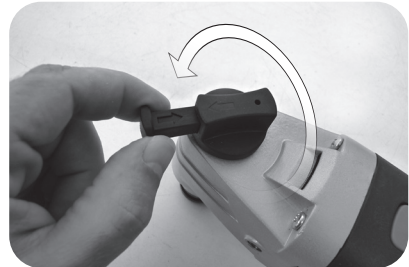
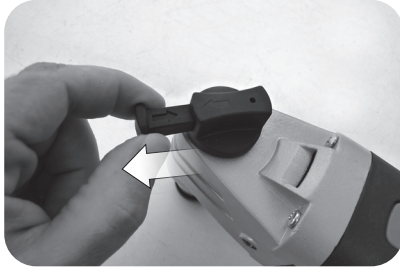



01

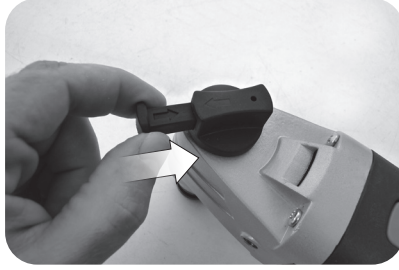
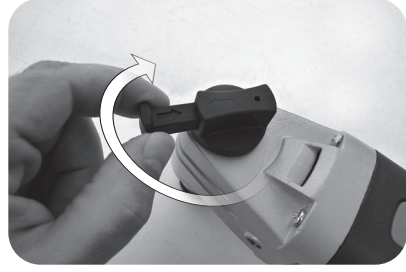

02

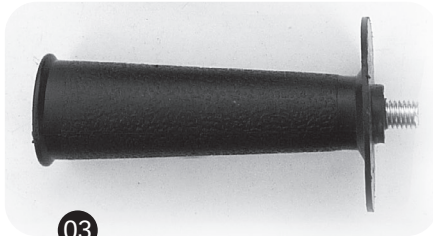

03





03

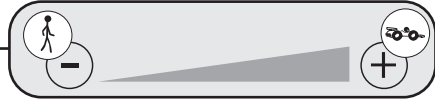
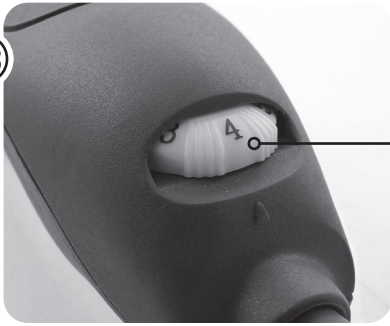

04

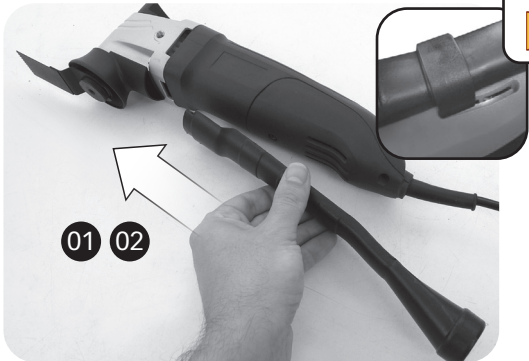
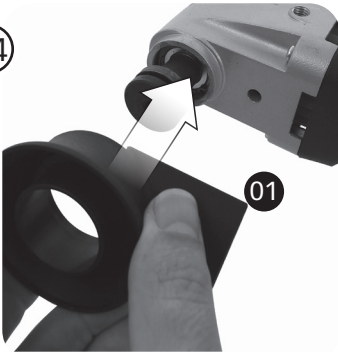

05



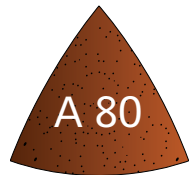
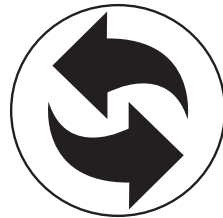

06





	<p>Tension et fréquence assignée : Nominal frequency and power: Spannung und Frequenz: Tensión y frecuencia fijada: Tensione e frequenza assegnata: Tensão e frequência fixa: Aangewezen spanning en frequentie: Ονομαστική τάση και συχνότητα: Napięcie i częstotliwość przydzielona: Jännite ja määrittäty taajuus: Angiven spänning och frekvens: Anført spænding og frekvens: Tensiune și frecvență de lucru:</p>	<p>Заданное напряжение и частота: Tahsis gerilimi ve frekansı: Stanovené napětí a frekvence: Stanovené napätie a frekvencia: מתח ותדר מוקצב. الغلطية والذبذبة المبرمجة. Névleges feszültség és frekvencia: Napetost in določena frekvenca: Консумирано напрежение и честота : Määratud pinge ja sagedus Nustatyta įtampa ir dažnis Noteiktais spriegums un frekvence. Napon i nazivna frekvencija:</p>	<p>230 V ~ 50 HZ</p>
---	---	--	----------------------

	<p>Puissance assignée : Nominal power: Leerlaufdrehzahl: Potencia fijada: Potenza assegnata: Potência assinada: Onbelast toerental: Ονομαστική ισχύς: Prędkość na biegu jałowym: Teho: Angiven effekt: Anført styrke: Putere de lucru:</p>	<p>Заданная мощность: Tahsis edilen güç: Stanovený príkon: Predpísaný výkon: כוח מוקצב. القدرة المبرمجة. Névleges teljesítmény : Določena jakost: Консумирана мощност: Määratud võimsus. Nustatyta galia Noteiktā jauda Nazivna snaga:</p>	<p>300 W</p>
---	--	--	--------------

	<p>Vitesse à vide : No-load speed: Drehzahl unbelastet: Velocidad vacía: Velocità a vuoto: Velocidade no vácuo: Leerlaufdrehzahl: Ταχύτητα αδράνειας: Prędkość bez obciążenia: Tyhjäkäyntinopeus Tomgångshastighet: Hastighed i ubelastet tilstand: Viteza în gol:</p>	<p>Скорость вращения на холостом ходу: Boşalma hızı: Rychlost naprázdno: Rýchlosť pri chode naprázdno: מהירות ריק. السرعة على الفارغ. Üres sebesség: Prosti tek: Скорост на празни обороти: Kiirus tühikäigul Tušćio prietaiso greitis Tukšgaitas ātrums Brzina praznog hoda:</p>	<p>15000-22000 .min⁻¹</p>
---	--	---	--------------------------------------

	<p>Poids : Weight : Gewicht : Peso : Peso : Peso : Gewicht : Βάρος : Masa : Paino : Vikt : Vægt : Greutate :</p>	<p>Vec : Ağırlık : Hmotnosť : Hmotnosť : משקל الوزن. Súly : Teža : Терло : Raskus Svoris Svars Težina:</p>	<p>1,6 kg</p>
---	--	--	---------------





	<p>Soumis à recyclage Subjected to recycling Sujeto a reciclaje Sottoposti a riciclaggio Sujeitos a reciclagem Não deite no lixo Niet wegwerpen Υπόκειται σε ανακύκλωση Nie wyrzucac Älä heitää pois luontoon Batteriet får inte kastas Bortkast det ikke Nu le auncati</p>	<p>Подлежит переработке Atmayıniz Nevyhadzujte je do bežného odpadu Neodhadzovat Gjenvinningspliktig فلا تدرجوا هنا في القمامة. ne mečíte1 Ne odvržite ga/jih vstran Taaskasutusse kuuluv Ärge visake seda minema Nemetykíte Nemest Podvrgnuto recikliranju</p>	×
---	---	---	---

Recyclage des déchets :

Les outils, accessoires et leur emballages doivent suivre une voie de recyclage adaptée. Conformément aux directives Européenne 2012/19/UE et 2006/66/CE, les composants d'un produit doivent être séparés, collectés, recyclés ou éliminés en conformité avec les réglementations environnementales en vigueur. Les appareils, batteries, piles, huiles, emballages devront être déposés dans les systèmes d'élimination des déchets spéciaux tels que déchetteries. Renseignez-vous auprès de votre commune pour connaître l'organisme le plus proche à même de retraiter ou de collecter ces déchets.

	<p>Recyclable, soumis au tri sélectif Recyclable, subject to recycling Recyclingfähige, unterliegen Recycling Reciclables, sujetos a reciclaje Riciclabili, soggetti a riciclaggio Recicláveis, sujeito à reciclagem Recycleerbare, onderworpen aan recycling Ανακυκλώσιμο, υπόκειται σε επιλεκτική διαλογή Opakowanie nadaje się do recyklingu podlegają recyklingu Kierrätettävien pakkausten kohteena kierrätys Återvinningsbara förpackningar omfattas återvinning Рециклиращи се опаковки подлежат на рециклиране Genanvendelig underlagt genbrug</p>	<p>Reciclabile sub rezerva reciclare Повторно упаковка подлежит вторичной переработке Gerí donúšúm Gerí donúštúrólebilir ambalaj konusu Recyklovateľné podľehajúci recyklácii Recyklovateľné podliehajúce recyklácii Resirkulerbar, med förbehold om selektiv sortering رېودنلې څاړل څاړل پرضخړت رېودنلې څاړل ټولټاړلې څاړل څاړل څاړل Újrahasznosítható csomagolás alá újrahasznosítás Reciklirati predmet recikliranja Pakendite suhtes ringlussevõtu Pārstrādājams iepakojums otrreizējai pārstrādei Perdirbamų taikomos perdirbimo Može se reciklirati, podložno selektivnom sortiranju</p>	×
---	--	--	---





	<p>Lire les instructions avant usage : Read the instructions before use : Vor Einsatz des Geräts Anweisung lesen : Léase las instrucciones antes de usar : Leggere le istruzioni prima dell'uso : Ler as instruções antes da utilização : Lees voor het gebruik de instructies : Διαβάστε τις οδηγίες πριν από τη χρήση: Zapoznać się z instrukcją przed użyciem : Lue ohjeet ennen käyttöä : Läs anvisningarna före användning : læs instruktionerne før brug Înainte de utilizare, citiți instrucțiunile :</p>	<p>Внимательно прочитайте следующие инструкции : Kullanmadan talimatları okuyunuz : Pozorně si přečtěte následující pokyny : Pred použitím si prečítajte pokyny : קראו את הלימודים קודם לשימוש. התאמה לתקנים האירופיים مطابق للمواصفات الأوروبية. használat előtt olvassuk el az utasítást : Pred uporabo preberite ustrežna navodila : Прочетете указанията за употреба : Enne kasutamist lugege instruksiooni Prieš naudojimą perskaityti instrukciją izlasīt instrukcijas pirms lietošanas Pročitati upute prije uporabe:</p>	X
---	--	--	---



	<p>Conformité européenne : Conforms to EC standards : CE-Konformität : Cumple con las directivas CE : Conforme alle norme CE : Conforme às normas CE : Voldoet aan de EG-normen : Ευρωπαϊκή Συμμόρφωση: Zgodność z normami CE : EU-standardien mukainen : EU-standardien mukainen : Overholder EU standarderne : Conform cu normele europene:</p>	<p>соответствие европейским стандартам: Avrupa uygunluk : Evropská shoda : Európska dohoda : התאמה לתקנים האירופיים مطابق للمواصفات الأوروبية. Evropska ustreznost : Európai megfeleléség : Съответствие с европейските норми : Euroopa Liidu vastavusmärk Europinių normų atitikima Atbilstība Eiropas standartiem Europska sukladnost</p>	X
---	---	---	---

	<p>Classe d'isolement : 2 Insulation class : 2 Isolierung klasse : 2 Aislamiento clase :2 Isolamento classe :2 Isolamento classe :2 Isolatie Klasse : 2 Κατηγορία μόνωσης: 2 Izolacja Klasy :2 Eristysluokka :2 Isolering Klass :2 Isoleringsklasse 2 Clasă izolație :2</p>	<p>Класс изоляции 2 : Yalıtım derecesi :2 Třída izolace :2 Izolačný systém 2 סוג בידוד 2. فئة العزل 2. Szigetelési osztály :2 Razred izolacije :2 Инструмент Клас :2 Isolatsiooniklass 2 Izolācijas rūšis 2 Izolācijas klase 2 Izolacija klasa: 2</p>	X
---	---	---	---

	<p>Danger : Danger : Gefahr : Peligro : Pericolo : Perigo : Gevaar : Κίνδυνος: Niebezpieczeństwo : Vaara : Fara : Fare : Pericol :</p>	<p>Опасно : Tehlike : Nebezpečí : Nebezpečnostvo : סכנה. خطر. Veszély : Nevarnost: Опасно : Oht Pavojus Bīstamība Opasnost:</p>	X
---	--	---	---







  	<p>Porter des lunettes de sécurité : Porter un masque anti-poussière: Porter une protection auditive:</p> <p>Wear protective eyewear : Wear a dust mask : Wear hearing protective equipment:</p> <p>Schutzbrille tragen : Staubschutzmaske tragen : Gehörschutz tragen:</p> <p>Llevar puestas gafas protectoras : Llevar puesta una careta de protección contra el polvo : Llevar puesta una protección auditiva:</p> <p>Portare de gli occhiali di sicurezza : Indossare una mascherina anti-polvere : Portare una protezione uditiva:</p> <p>Utilizar óculos de segurança : Utilizar uma máscara anti-poeira : Utilizar uma protecção auditiva:</p> <p>Draag een veiligheidsbril : Draag een stofmasker : Draag gehoorbeschermers:</p> <p>Φοράτε προστατευτικά γυαλιά: Φορέστε μάσκα για τη σκόνη: Φοράτε προστασία ακοής:</p> <p>Zakładać okulary ochronne : Zakładać maskę przeciwpyłową Zakładać słuchawki ochronne</p> <p>Käytä suojalaseja : Käytä pölysuojust : Käytä kuulosuojaimia:</p> <p>Använd skyddsglasögon : Bär mask mot damm : Bär hörselskydd:</p> <p>Der skal benyttes sikkerhedsbriller : Der skal benyttes beskyttelsesmaske mod støv: Der skal benyttes høreværn:</p> <p>Purtați ochelari de protecție : Purtați mască anti-praf : Purtați căști de protecție auz:</p>	<p>Наденьте защитные очки : Наденьте респиратор : наденьте средства звуковой защиты:</p> <p>Güvenlik gözlükleri takın : Toza karşı maske takın : İşitsel koruma aleti takın:</p> <p>Používejte bezpečnostní brýle : Používejte masku proti prachu : Používejte ochranu sluchu:</p> <p>Noste ochranné okuliare : Noste ochrannú masku proti prachu : Noste ochranné slúchadlá:</p> <p>תחזיתו יפקשם ביכרהל אנ קבא דגנ הכסמ שובחל אנ יש ל הרכיב הגנת שמיעה חמל נזפארט וקאיא. ליבס קנזאע חפזאז ללדגבאר. ליבס חוזה פרזאז אלזחגיח.</p> <p>Viseljen védőszemüveget : Viseljen porvédő maszkot Viseljen fülvédőt</p> <p>Nositi zaščitna očala : Nositi zaščitno masko proti prahu: Nositi zašito ušes:</p> <p>Да се използват защитни очила : Да се използва защитна маска : Да се използва слухови защитни средства:</p> <p>Kandke kaitseprille Kandke tolumumaski. Kandke kõrvakaitset</p> <p>Nešioti apsauginius akinius Dėvėti respiratorių Nešioti apsaugą nuo triukšmo</p> <p>Valkät aizsargbrilles Valkät aizsarg masku pret putekļiem valkät dzirdes aizsarglīdzekļi</p> <p>Nositi zaštitne naočale: Nositi masku za zaštitu od prašine: Nositi štítznike protiv buke:</p>	X
---	---	--	---

	<p>Porter des gants : Use rubber gloves : Schutzhandschuhe tragen : Llevar guantes de protección : Indossare i guanti di protezione : Utilizar luvas de protecção : Draag veiligheidshandschoenen : Φορώντας γάντια: Używać rękawic ochronnych : Käytä suojakäsineitä : Använd skyddshandskar : Der skal benyttes handsker : Purtați mănuși :</p>	<p>Наденьте перчатки : Eldiven takın : Noste rukavice : Noste rukavice : תופכב שובחל אנ ליבס קפארזאז. Viseljen kesztyű t Nositi rokavice: а се използват предпазни ръкавици : Kandke kindaid Müvēti pirštines Valkät cimdu Nositi zaštitne rukavice:</p>	X
---	---	--	---





 L_{pA}	Niveau de pression acoustique :	Уровень акустического давления :	84 dB (A)
	Acoustic pressure level :	Akustik basınç seviyesi :	
	Schalldruckpegel :	Hladina akustického tlaku :	
	Nível de presión acústica :	Hladina akustického tlaku :	
	Livello di pressione acustica :	רמת לחץ אקוסטי.	
	Nível de pressão acústica :	مستوى الضغط الاعمى.	
	Niveau akoestische druk :	A hangnyomás szintje :	
	Στάθμη ηχητικής πίεσης:	Nivo akustičnega pritiska:	
	Poziom mocy akustycznej :	Равнище на акустично налягане :	
	Käytä kuulosuojaimia:	Helirõhu nivoo	
Ljudtrycksnivå :	Akustinio spaudimo lygis		
Lydtryk :	Akustiskā spiediena līmenis		
Nível presiune acustică :	Razina zvučnog tlaka:		

 L_{wA}	Niveau de puissance acoustique :	уровень мощности звука :	95 dB (A)
	Acoustic power level :	Akustik basınç seviyesi :	
	Schalleistungspegel :	Hladina zvukového výkonu:	
	Nível de potencia acústica :	Hladina zvukového výkonu:	
	Livello di potenza acustica:	רמת כוח אקוסטי.	
	Nível de potência acústica:	مستوى الضغط الاعمى.	
	Niveau akoestisch vermogen :	a hangnyomás szintje :	
	Επίπεδο ισχύος ήχου:	Nivo akustične jakosti :	
	Poziom mocy akustycznej :	Равнище на вибрации :	
	Käytä suojalaseja :	Helivõimsuse nivoo	
Ljudstyrkenivå :	Triukšmo lygis		
Lydstyrke :	Akustiskās jaudas līmenis		
Nível putere acustică :	Razina zvučne snage:		

NIVEAU SONORE D'ÉMISSION :

A VIDE

Pression acoustique L_{pA} poste opérateur
Incertitude

84 dB
3

Puissance acoustique L_{wA}
Incertitude

95 dB
3

Valeurs déterminées suivant le code d'essai de l'annexe B de la norme EN 61029-1 avec emploi des normes de base ISO 11201 et ISO 3744.

Les niveaux de pression acoustique obtenus in situ dépendent :

- Des niveaux réels de la machine considérées, en prenant en compte les incertitudes déclarées;
- Du local et de l'installation de la machine. Préférez une pièce dont l'acoustique est plus feutrée.

Evitez les pièces vides à grande résonance. Placez vous auprès d'une fenêtre le cas échéant.

- Des outils montés, des pièces travaillées, des réglages choisis,...

 L_v	Niveau de vibration :	Уровень вибрации :	3,55 m / s ²
	Hand/arm vibration level :	Titreşim seviyesi :	
	Vibrationspegel Hand/Arm :	Úroveň vibrací :	
	Nível de vibración mano/brazo :	Hladina vibrácií :	
	Livello di vibrazione mano/braccio :	רמת תנודות	
	Nível de vibração mão/braço :	مستوى الارتجاج.	
	Trillingsniveau hand/arm :	Vibrációszint :	
	Επίπεδο κραδασμών:	Nivo vibracij :	
	Poziom wibracji rózka/ramię :	Равнище :	
	Tärinätaso:	Vibrācijas līmenis.	
Vibrationsnivå hand/arm :	Vibracijos lygis		
Vibrations niveau :	Vibratsiooni nivo		
Nível vibrații :	Razina vibracije:		

VIBRATIONS:

Total des valeurs de vibration (somme vectorielle des trois directions) déterminée selon EN 60745 :

a

3,55 m/s²

Incertitude K

1,5 m/s²

L'amplitude d'oscillation peut être utilisée comme valeur de comparaison d'outils électroportatifs.

Attention : si l'outil électroportatif est utilisé pour d'autres applications, avec d'autres outils de travail, l'amplitude d'oscillation peut être différente.





DM 300

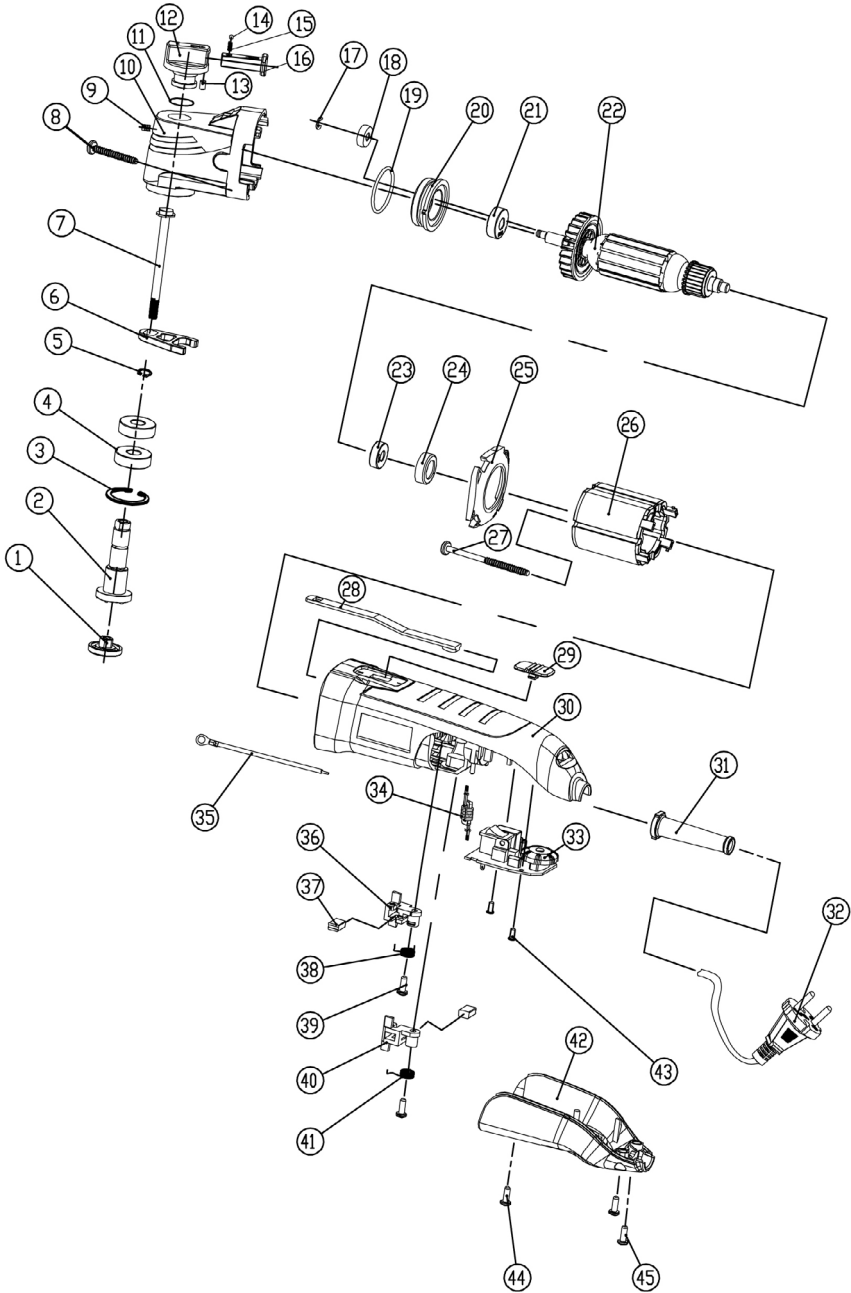



115145-2-Sticker-C.indd 1

11/05/2022 17:06

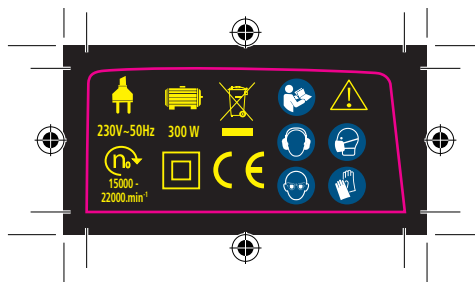

115145-2-Sticker-C.indd 2

11/05/2022 17:06



GARANTIE - WARRANTY



FR. GARANTIE

Cet outil est garanti contractuellement contre tout vice de construction et de matière, à compter de la date de vente à l'utilisateur et sur simple présentation du ticket de caisse. La garantie consiste à remplacer les parties défectueuses. Cette garantie n'est pas applicable en cas d'exploitation non conforme aux normes de l'appareil, ni en cas de dommages causés par des interventions non autorisées ou par négligence de la part de l'acheteur. La garantie ne s'applique pas sur les dommages causés par une défaillance de l'outil.

DE. GARANTIE

Die Garantiezeit für dieses Gerät in bezug auf Konstruktions- und Materialfehler beträgt lt. Vertrag bei Vorlage des Kassensbons. Die Garantieleistung besteht im Ersatz schadhafter Teile. Die Garantie erlischt bei einem Einsatz des Geräts, der nicht normentsprechend ist, bei Schäden, die auf unsachgemäße Eingriffe zurückzuführen sind bzw. bei Nachlässigkeit seitens des Käufers. Die Garantie erstreckt sich nicht auf Schäden, die auf Fehlfunktionen des Geräts zurückzuführen sind.

IT. GARANZIA

Quest' attrezzo è garantito per contratto contro qualsiasi difetto di costruzione e di materia, a partire dalla data di vendita all' utente e su semplice presentazione dello scontrino. La garanzia consiste nel sostituire le parti difettose. Questa garanzia non è applicabile in caso di sfruttamento non conforme alle norme dell' apparecchio, né in caso di danni causati da interventi non autorizzati o da negligenza da parte dell' acquirente. La garanzia non si applica ai danni causati da un avaria dell' attrezzo.

FN. GARANTIE

This tool is guaranteed, in writing, against any defect in manufacture of parts from the date of sale, upon simple presentation of the sales slip. The guarantee is limited to the replacement of faulty parts. This guarantee is not applicable in the event of usage which is not conform with the intended usage of the apparatus, nor in the event of damage caused by unauthorised servicing or negligence on behalf of the purchaser. This guarantee does not apply to any damage caused by

the failure of this tool.

ES. GARANTIA

Esta herramienta se garantiza contractualmente contra todo defecto de construcción y materia, a partir de la fecha de venta a l' usuario y sobre simple presentación del recibo de caja. La garantía consiste en sustituir a las partes defectuosas. Esta garantía no es aplicable en caso de explotación no conforme a las normas del aparato, ni en caso de daños causados por intervenciones no autorizadas o por negligencia por parte del comprador. La garantía no se aplica sobre los daños causados por un fallo del herramienta.

NL. GARANTIE

Dit gereedschap heeft een garantie tegen constructierouten en materiaaldefecten, die geldig is vanaf de aankoopdatum door de gebruiker, op vertoning van de kassabon. De garantie betreft de vervanging van de defecte onderdelen. Deze garantie is niet van toepassing indien het apparaat niet volgens de normen gebruikt is, noch in geval van schade veroorzaakt door oneigenlijk gebruik of nalatigheid van de koper. De garantie is niet van toepassing op schade voortvloeiend uit een defect van het gereedschap.

PT. GARANTIA

Esta ferramenta tem uma garantia contratual contra qualquer defeito de construção e de material, a partir da data de venda ao utilizador e sobre simples apresentação do talão da caixa. A garantia consiste em substituir as partes defeituosas. Esta garantia não é aplicável no caso de exploração não conforme as normas do aparelho, nem em caso de danos causados pelas intervenções não autorizadas ou por negligência da parte do comprador. A garantia não se aplica para os danos causados por uma falha da ferramenta.

EL. ΓΑΡΑΝΤΙΑ

Αυτό το εργαλείο είναι συμβατικά εγγυημένο για οποιοδήποτε κατασκευαστικό και υλικό ελάττωμα, από την ημερομηνία πώλησης στον χρήστη και με την επίδειξη της απόδειξης πώλησης. Η εγγύηση συνίσταται στην αντικατάσταση των ελαττωματικών εξαρτημάτων. Αυτή η εγγύηση δεν ισχύει σε περίπτωση λειτουργίας που δεν συμμορφώνεται με τα πρότυπα της συσκευής, ούτε σε περίπτωση ζημιάς που προκαλείται από μη εξουσιοδοτημένες επεμβάσεις ή αμελεία εκ μέρους του αγοραστή. Η εγγύηση δεν ισχύει για ζημιές που προκαλούνται από αστοχία εργαλείου.

PL. GWARANCJA

Narz dzie jest objte gwarancja na wszelkie wady konstrukcyjne i materiałowe, licząc od daty sprzedaży u użytkownika i po

okazaniu, paragonu, kasowego. Gwarancja obejmuje wymianę cz.ści wybrakowanych. Gwarancja nie znajduje zastosowania w przypadku uytkowania, niezgodnego z normami urzadzzenia, ani w przypadku szkod spowodowanych działaniami niedozwolonymi lub zaniedbaniami ze strony nabywcy. Gwarancja nie obejmuje szkod powstających z powodu upadku urzadzzenia.

SV. GARANTI

Detta verktyg har en avtalsenlig garanti mot konstruktions- och materialfel, från och med tidpunkten för användarens inköp och genom uppvisning av kassakvittot. Garantin består i att ersätta de bristfälliga delarna. Denna garanti gäller inte om användningen inte motsvarar apparatens standarder, inte heller vid skador som orsakas av ej tillåtna ingrepp eller på grund av Koparens vårdslöshet. Garantin gäller inte forskador som orsakats av att verktyget fungerat bristfälligt.

FI. TAKU

Tämän laitteen takuu on voimassa sopimuksenmukaisesti kattaaen kaikki rakennne- ja materiaali- ja lukien ostopäivästä, kassakuittia vastaan. Takuu sisältää viallisten osien korvaamisen. Takuu ei korvaa ohjeiden- vastaista käyttöä eikä vialtuuttamattomien henkilöiden kasiteltysta tai ostajan huolimattomuudesta aiheutuneita vahinkoja. Takuu ei vastaa myöskään toimintahairiöistä aiheutuneita vahinkoja.

BU. Гаранция

Този инструмент е под договорна гаранция срещу всякакъв дефект в изработката и използваните материали, считано от датата на продажба на потребителя и само срещу представяне на касовата бележка. Гаранционното обслужване се състои в замяна на дефектните части. Настоящата гаранция не е валидна когато апаратът се използва по начин, несъответстващ на стандарта за работа с него, както и в случай на щети, нанесени от неоторизирани лица, или вследствие на проявена небрежност от страна на потребителя. Гаранцията не покрива щети, произтекли вследствие на техническа неизправност на апарата.

DA. GARANTI

Dette værktøj er dækket af en garantikontrakt for konstruktions- og materialefej, som gælder fra købsdatoen ved visning af kassebonen. Garantien består i at udskifte de defekte dele. Garantien dækker ikke fejl opstået som følge af anvendelse, som ikke overholder standarderne for apparatet, eller

SERVICE APRÈS VENTE - AFTER SALE SERVICE

FARGROUP EUROPE - 192, Avenue Yves Farge - 37700 St. Pierre-des-Corps - FRANCE

fargroup@fargroup.net

GARANTIE - WARRANTY



skader opstået ved ikke autoriserede indgreb eller sløsethed fra brugerens side. Garantien dækker ikke skader opstået, fordi værktøjet har svigtet.

RO. GARANTIE

Acest aparat este garantat din punct de vedere contractual împotriva tuturor vicilor de construcție și de material, începând de la data vânzării lui către utilizator și la simpla prezentare a bunului de casă. Garanția constă în înlocuirea componentelor defecte. Această garanție nu se aplică în cazul exploatarii în alt mod decât cel recomandat de normele aparatului și nici în caz de stricăciuni provocate de intervenții neautorizate sau prin neglijența comparatorului. Garanția nu se aplică asupra pagbelor cauzate de o defectare a aparatului.

RU. ГАРАНТИЯ

Данное изделие обладает имеющей силу гарантии, все возможные дефекты изготовления и материала. Гарантия вступает в силу с даты продажи изделия пользователю, для этого достаточно сохранить и предъявить полученный в кассе чек. Гарантия обязывает изготовителя заменить дефектные части изделия. В случае не соответствующего нормам использования изделия, несанкционированного демонтажа или ремонта или небрежного обращения действие гарантии прекращается. Гарантия не покрывает ущерба, возникшего в результате сбоя в работе изделия.

TU. GARANTI

Bu arac, satis tarihinden itibaren, kullanıcının sadesce vezne alındisini sunmasiyia tum uretim ve malzeme hatasina karsi garantilidir. Garanti eksik olan kisimlari degistirmek icindir. Bu garanti aracın sartlarina uygun olmayan isleme durumunda izin verilmeyen kullanimlardan kaynaklanan hasarlarda veya alicinin istegi durumunda uygulanmaz. Garanti malzemenin bir eksikliginden meydana gelen bir zararda uygulanmaz.

CS. ZÁRUKA

Pro tento nástroj platí smluvní záruka na všechny výrobní a materiálové vady od data prodeje uživateli a na základě předložení pokladního bloku. Záruka spocívá ve výmene vadných částí. Táto záruka neplatí v prípade použiti prístroje, ktoré

neodpovídá normám, ani v prípade škod spôsobených nepovolenými zásahy alebo nedbalosti ze strany kupujúceho. Záruka sa nevzťahuje na škody spôsobené závadou nástroje.

SK. ZÁRUKA

Pre tento nástroj platí zmluvná záruka na všetky výrobné a materiálové chyby od dátumu predaja užívateľovi a na základe predloženia pokladničného bloku. Záruka spocíva vo výmene chybných častí. Táto záruka neplatí v prípade použiti prístroja, ktore hezodpovedá normám, ani v prípade škod spôsobených nepovolenými zásahmi alebo nedbalostou zo strany kupujúceho. Záruka sa nevzťahuje na škody spôsobené poruchou nástroja

AR. الضمان

ق لعنتي عارثشلاقطاب ميديقت درجم بلع اعابوب لعنسملا بلا عيبلأ خيرات نم اربعتا داوملافوق بنصتلا يف بيع يا نم اندقاعت قنومضم قد علا هذه تاا تافاللتال فصرعت لأحف الو بزاهجلا ربناعمل قناطملار ربع مادختسالا ألاح يف قنيطنلل البااق نامضلا اذه نوكي ال أقطاعلا عارثجالا لأديتس ياأف نامضلا للبح نم حثانلا رضلا بلع نامضلا قنيطني ال برتشملا ليق نم لامهالا لأح يف وأ قصخوم ربع لحدث تاللمع نم حثان

HU. GARANCIA

Erre a szerszámra szerződéses garanciát vállalunk bármilyen gyártási es anyagi hibára felmerülő esetere a fogvaszto reszere törtent eladás napjától számítva a penztári blokk egyszere felmutatása elleneben. A garancia a hibás alkatrészek cserejére terjed ki. Ez a garancia nem ervenyes, ha a készuleket nem rendelteszzeruen használtak, sem illetektelen beavatkozások vagy a vásárló hanyagsága okozta karok eseten. A garancia nem fedezi azokat a karokat, melyeket a szerszam hibas mukodese okozott.

SL. GARANCIJA

To orodje je z garancijsko pogodbo zašcitero proti vsem napakam v izdelavi in v sestavnem materialu od datuma prodaje naprej in ta velja ob predložitvi blagajniškega racunja. Garancija velja za zamenjavo delov z napako. Ta garancija ne velja za uporabo orodja, ki ni v skladu z normami, predpisanimi za omenjeno orodje in za primere okvar, ki nastanejo zaradi nedovoljenih posegov na orodju ali zaradi malomarnega rokovanja kupca. Garancija ne velja za škodo, ki jo lahko povzroci okvara orodja.

ET. GARANTII

See tööriist kuulub lepingu järgi garantiiremonti arvestades alates müümise päevast ja kasutatakse alusel kasutatavale kõigi konstruktsiooni- ja materjalivigade puhul. Garantii seisneb defektsete osade vahetamises. See garantii ei kehti

aparaadi normide ebatavalise eiramise puhul ega ostja poolt keelatud viisil kasutamises või hooletusetahtmises tulenevate kahjude korral. Garantii ei kehti seadme defektidest põhjustatud kahjude puhul

LV. GARANTĪJA

Sis prietaisas yra uztikrinamas kaip itin geros kokybes, nuo jo pardavimo datos iki jo panaudojimo, ir jam yra suteikiamas garantinis talonas. Suteiktos metu galima pakeisti atsiradusius trumplataikius gedimus. Si garantija netaikoma esant netinkamam naudojimui ar nesilaikant reikiam siu aparato vartojimo instrukciju, tai pat paciam virtojui ji sugadinus. Garantija taip pat netaikoma, prietaisa naudojant ne pagal paskirti ir ji apgadinus

LT. GARANTUJA

Sim darbarikam ir liguma noteikta garantija visiem defektiem, kas saistas ar konstrukciju un materialu, sakot ar pardosanas datumu, kad masinu, pardod lietotajam un vienkarši uzradot kases ceku. Garantija ieklau bojoto dalu nomainu. Si garantija nav deriga, ja aparats nav lietots saskaņa ar drošibas noteikumiem, ne gadījumos ja bojājumi radusies nesankcionētas ietaukšanas gadījuma vai arī piercēja nolaidības dēļ. Garantija nav derīga, ja bojājumi radusies darbarika defekta dēļ

HR. JAMSTVO

Ovaj alat ima ugovorno jamstvo u slucaju bilo kakvih nedostataka u konstrukciji i materijalu, od datuma prodaje korisniku uz jednostavno potdocenje racuna. Jamstvo se sastoji u zamjeni neispravnih dijelova. Ovo se jamstvo ne primjenjuje u slucaju uporabe i eksploatacije koja nije sukladna standardima uređaja, niti u slucaju štete uzrokovane neovlastenim intervencijama ili nemarom kupca. Jamstvo se ne primjenjuje na štetu uzrokovanu nekim nedostatkom alata.

SERVICE APRÈS VENTE - AFTER SALE SERVICE

FARGROUP EUROPE - 192, Avenue Yves Farge - 37700 St. Pierre-des-Corps - FRANCE
fargroup@fargroup.net



FAR GROUP EUROPE

Une société du groupe **SIGMA**

192, Avenue Yves Farge
37700 St. Pierre-des-Corps
FRANCE

www.fartools.com

